

- NOTES
- DRAWING PREPARED IN ACCORDANCE WITH ASME Y14.100-2000.
  - INTERPRET DIMENSIONS AND TOLERANCES PER ANSI Y14.5M-1994.
  - DIMENSIONS ARE IN INCHES.
  - DRAWING DEPICTS FLAT PATTERN OF FORMED PARTS DEFINED BY PRO/ENGINEER FILES SEI42C-486-XXX.PRT.
  - PROFILE TOLERANCE OF FLAT PATTERN IS +/- .010 IN.
  - THICKNESS IS 0.040 +/- .006 IN. PER ASTM B248.
  - REMOVE ALL BURRS AND SHARP EDGES.
  - IDENTIFY PARTS WITH "PART NAME" BY ETCHING OR PERMANENT MARKER.
  - INDICATED PARTS TO BE NEMA GRADE G1ICR MATERIAL.

INSTANCE NAME	HOLE	S-DIM	PART NAME	INSTANCE NAME	HOLE	S-DIM	PART NAME
SEI42C-486_FLAT_270		0.8854170	SEI42C-486-270	SEI42C-486_FLAT_174-NEW		0.3854170	SEI42C-486-174
SEI42C-486_FLAT_271	1	0.8906250	SEI42C-486-271	SEI42C-486_FLAT_175-NEW	49	0.3906250	SEI42C-486-175
SEI42C-486_FLAT_272		0.8958330	SEI42C-486-272	SEI42C-486_FLAT_176-NEW		0.3958330	SEI42C-486-176
SEI42C-486_FLAT_273	2	0.9010420	SEI42C-486-273	SEI42C-486_FLAT_177-NEW	50	0.4010420	SEI42C-486-177
SEI42C-486_FLAT_274		0.9062500	SEI42C-486-274	SEI42C-486_FLAT_178		0.4062500	SEI42C-486-178
SEI42C-486_FLAT_275	3	0.9114580	SEI42C-486-275	SEI42C-486_FLAT_179	51	0.4114580	SEI42C-486-179
SEI42C-486_FLAT_276		0.9166670	SEI42C-486-276	SEI42C-486_FLAT_180		0.4166670	SEI42C-486-180
SEI42C-486_FLAT_277	4	0.9218750	SEI42C-486-277	SEI42C-486_FLAT_181	52	0.4218750	SEI42C-486-181
SEI42C-486_FLAT_278		0.9270830	SEI42C-486-278	SEI42C-486_FLAT_182		0.4270830	SEI42C-486-182
SEI42C-486_FLAT_279	5	0.9322920	SEI42C-486-279	SEI42C-486_FLAT_183	53	0.4322920	SEI42C-486-183
SEI42C-486_FLAT_280		0.9375000	SEI42C-486-280	SEI42C-486_FLAT_184		0.4375000	SEI42C-486-184
SEI42C-486_FLAT_281	6	0.9427080	SEI42C-486-281	SEI42C-486_FLAT_185	54	0.4427080	SEI42C-486-185
SEI42C-486_FLAT_282		0.9479170	SEI42C-486-282	SEI42C-486_FLAT_186		0.4479170	SEI42C-486-186
SEI42C-486_FLAT_283	7	0.9531250	SEI42C-486-283	SEI42C-486_FLAT_187	55	0.4531250	SEI42C-486-187
SEI42C-486_FLAT_284		0.9583330	SEI42C-486-284	SEI42C-486_FLAT_188		0.4583330	SEI42C-486-188
SEI42C-486_FLAT_285	8	0.9635420	SEI42C-486-285	SEI42C-486_FLAT_189	56	0.4635420	SEI42C-486-189
SEI42C-486_FLAT_286		0.9687500	SEI42C-486-286	SEI42C-486_FLAT_190		0.4687500	SEI42C-486-190
SEI42C-486_FLAT_287	9	0.9739580	SEI42C-486-287	SEI42C-486_FLAT_191	57	0.4739580	SEI42C-486-191
SEI42C-486_FLAT_288		0.9791670	SEI42C-486-288	SEI42C-486_FLAT_192		0.4791670	SEI42C-486-192
SEI42C-486_FLAT_289	10	0.9843750	SEI42C-486-289	SEI42C-486_FLAT_193	58	0.4843750	SEI42C-486-193
SEI42C-486_FLAT_290		0.9895830	SEI42C-486-290	SEI42C-486_FLAT_194		0.4895830	SEI42C-486-194
SEI42C-486_FLAT_291	11	0.9947920	SEI42C-486-291	SEI42C-486_FLAT_195-NEW	59	0.4947920	SEI42C-486-195
SEI42C-486_FLAT_292-NEW		0.0000000	SEI42C-486-292	SEI42C-486_FLAT_196		0.5000000	SEI42C-486-196
SEI42C-486_FLAT_101	12	0.0052080	SEI42C-486-101	SEI42C-486_FLAT_197	60	0.5052080	SEI42C-486-197
SEI42C-486_FLAT_102		0.0104170	SEI42C-486-102	SEI42C-486_FLAT_198-NEW		0.5104170	SEI42C-486-198
SEI42C-486_FLAT_103-NEW	13	0.0156250	SEI42C-486-103	SEI42C-486_FLAT_199-NEW	61	0.5156250	SEI42C-486-199
SEI42C-486_FLAT_104-NEW		0.0193410	SEI42C-486-104	SEI42C-486_FLAT_200-NEW		0.5208330	SEI42C-486-200
SEI42C-486_FLAT_106-NEW	14	0.0240000	SEI42C-486-106	SEI42C-486_FLAT_201	62	0.5260420	SEI42C-486-201
SEI42C-486_FLAT_107-NEW		0.0306000	SEI42C-486-107	SEI42C-486_FLAT_202		0.5312500	SEI42C-486-202
SEI42C-486_FLAT_108-NEW	15	0.0410000	SEI42C-486-108	SEI42C-486_FLAT_203	63	0.5364580	SEI42C-486-203
SEI42C-486_FLAT_109		0.0468750	SEI42C-486-109	SEI42C-486_FLAT_204		0.5416670	SEI42C-486-204
SEI42C-486_FLAT_110	16	0.0520830	SEI42C-486-110	SEI42C-486_FLAT_205	64	0.5468750	SEI42C-486-205
SEI42C-486_FLAT_111		0.0572920	SEI42C-486-111	SEI42C-486_FLAT_206		0.5520830	SEI42C-486-206
SEI42C-486_FLAT_112	17	0.0625000	SEI42C-486-112	SEI42C-486_FLAT_207	65	0.5572920	SEI42C-486-207
SEI42C-486_FLAT_113		0.0677080	SEI42C-486-113	SEI42C-486_FLAT_208		0.5625000	SEI42C-486-208
SEI42C-486_FLAT_114	18	0.0729170	SEI42C-486-114	SEI42C-486_FLAT_209	66	0.5677080	SEI42C-486-209
SEI42C-486_FLAT_115		0.0781250	SEI42C-486-115	SEI42C-486_FLAT_210		0.5729170	SEI42C-486-210
SEI42C-486_FLAT_116	19	0.0833330	SEI42C-486-116	SEI42C-486_FLAT_211	67	0.5781250	SEI42C-486-211
SEI42C-486_FLAT_117		0.0885420	SEI42C-486-117	SEI42C-486_FLAT_212		0.5833340	SEI42C-486-212
SEI42C-486_FLAT_118	20	0.0937500	SEI42C-486-118	SEI42C-486_FLAT_213	68	0.5885420	SEI42C-486-213
SEI42C-486_FLAT_119		0.0989580	SEI42C-486-119	SEI42C-486_FLAT_214		0.5937500	SEI42C-486-214
SEI42C-486_FLAT_120	21	0.1041670	SEI42C-486-120	SEI42C-486_FLAT_215	69	0.5989580	SEI42C-486-215
SEI42C-486_FLAT_121		0.1093750	SEI42C-486-121	SEI42C-486_FLAT_216		0.6041670	SEI42C-486-216
SEI42C-486_FLAT_122	22	0.1145830	SEI42C-486-122	SEI42C-486_FLAT_217	70	0.6093750	SEI42C-486-217
SEI42C-486_FLAT_123		0.1197920	SEI42C-486-123	SEI42C-486_FLAT_218		0.6145840	SEI42C-486-218
SEI42C-486_FLAT_124	23	0.1250000	SEI42C-486-124	SEI42C-486_FLAT_219	71	0.6197920	SEI42C-486-219
SEI42C-486_FLAT_125		0.1302080	SEI42C-486-125	SEI42C-486_FLAT_220		0.6250000	SEI42C-486-220
SEI42C-486_FLAT_126	24	0.1354170	SEI42C-486-126	SEI42C-486_FLAT_221	72	0.6302090	SEI42C-486-221
SEI42C-486_FLAT_127		0.1406250	SEI42C-486-127	SEI42C-486_FLAT_222		0.6354170	SEI42C-486-222
SEI42C-486_FLAT_128	25	0.1458330	SEI42C-486-128	SEI42C-486_FLAT_223	73	0.6406250	SEI42C-486-223
SEI42C-486_FLAT_129		0.1510420	SEI42C-486-129	SEI42C-486_FLAT_224		0.6458340	SEI42C-486-224
SEI42C-486_FLAT_130	26	0.1562500	SEI42C-486-130	SEI42C-486_FLAT_225	74	0.6510420	SEI42C-486-225
SEI42C-486_FLAT_131		0.1614580	SEI42C-486-131	SEI42C-486_FLAT_226		0.6562500	SEI42C-486-226
SEI42C-486_FLAT_132	27	0.1666670	SEI42C-486-132	SEI42C-486_FLAT_227	75	0.6614580	SEI42C-486-227
SEI42C-486_FLAT_133		0.1718750	SEI42C-486-133	SEI42C-486_FLAT_228		0.6666670	SEI42C-486-228
SEI42C-486_FLAT_134	28	0.1770830	SEI42C-486-134	SEI42C-486_FLAT_229	76	0.6718750	SEI42C-486-229
SEI42C-486_FLAT_135		0.1822920	SEI42C-486-135	SEI42C-486_FLAT_230		0.6770830	SEI42C-486-230
SEI42C-486_FLAT_136	29	0.1875000	SEI42C-486-136	SEI42C-486_FLAT_231	77	0.6822920	SEI42C-486-231
SEI42C-486_FLAT_137		0.1927080	SEI42C-486-137	SEI42C-486_FLAT_232		0.6875000	SEI42C-486-232
SEI42C-486_FLAT_138	30	0.1979170	SEI42C-486-138	SEI42C-486_FLAT_233	78	0.6927080	SEI42C-486-233
SEI42C-486_FLAT_139		0.2031250	SEI42C-486-139	SEI42C-486_FLAT_234		0.6979170	SEI42C-486-234
SEI42C-486_FLAT_140	31	0.2083330	SEI42C-486-140	SEI42C-486_FLAT_235	79	0.7031250	SEI42C-486-235
SEI42C-486_FLAT_141		0.2135420	SEI42C-486-141	SEI42C-486_FLAT_236		0.7083330	SEI42C-486-236
SEI42C-486_FLAT_142	32	0.2187500	SEI42C-486-142	SEI42C-486_FLAT_237	80	0.7135420	SEI42C-486-237
SEI42C-486_FLAT_143-NEW		0.2239580	SEI42C-486-143	SEI42C-486_FLAT_238		0.7187500	SEI42C-486-238
SEI42C-486_FLAT_144-NEW	33	0.2291670	SEI42C-486-144	SEI42C-486_FLAT_239	81	0.7239580	SEI42C-486-239
SEI42C-486_FLAT_145-NEW		0.2343750	SEI42C-486-145	SEI42C-486_FLAT_240-NEW		0.7291670	SEI42C-486-240
SEI42C-486_FLAT_146-NEW	34	0.2395830	SEI42C-486-146	SEI42C-486_FLAT_241-NEW	82	0.7343750	SEI42C-486-241
SEI42C-486_FLAT_147		0.2447920	SEI42C-486-147	SEI42C-486_FLAT_242-NEW		0.7395830	SEI42C-486-242
SEI42C-486_FLAT_148	35	0.2500000	SEI42C-486-148	SEI42C-486_FLAT_243-NEW	83	0.7447920	SEI42C-486-243
SEI42C-486_FLAT_149		0.2552080	SEI42C-486-149	SEI42C-486_FLAT_244-NEW		0.7500000	SEI42C-486-244
SEI42C-486_FLAT_150	36	0.2604170	SEI42C-486-150	SEI42C-486_FLAT_245	84	0.7552080	SEI42C-486-245
SEI42C-486_FLAT_151		0.2656250	SEI42C-486-151	SEI42C-486_FLAT_246		0.7604170	SEI42C-486-246
SEI42C-486_FLAT_152	37	0.2708330	SEI42C-486-152	SEI42C-486_FLAT_247	85	0.7656250	SEI42C-486-247
SEI42C-486_FLAT_153		0.2760420	SEI42C-486-153	SEI42C-486_FLAT_248		0.7708330	SEI42C-486-248
SEI42C-486_FLAT_154	38	0.2812500	SEI42C-486-154	SEI42C-486_FLAT_249	86	0.7760420	SEI42C-486-249
SEI42C-486_FLAT_155		0.2864580	SEI42C-486-155	SEI42C-486_FLAT_250		0.7812500	SEI42C-486-250
SEI42C-486_FLAT_156	39	0.2916670	SEI42C-486-156	SEI42C-486_FLAT_251	87	0.7864580	SEI42C-486-251
SEI42C-486_FLAT_157		0.2968750	SEI42C-486-157	SEI42C-486_FLAT_252		0.7916670	SEI42C-486-252
SEI42C-486_FLAT_158	40	0.3020830	SEI42C-486-158	SEI42C-486_FLAT_253	88	0.7968750	SEI42C-486-253
SEI42C-486_FLAT_159		0.3072920	SEI42C-486-159	SEI42C-486_FLAT_254		0.8020830	SEI42C-486-254
SEI42C-486_FLAT_160	41	0.3125000	SEI42C-486-160	SEI42C-486_FLAT_255	89	0.8072920	SEI42C-486-255
SEI42C-486_FLAT_161		0.3177080	SEI42C-486-161	SEI42C-486_FLAT_256		0.8125000	SEI42C-486-256
SEI42C-486_FLAT_162	42	0.3229170	SEI42C-486-162	SEI42C-486_FLAT_257	90	0.8177080	SEI42C-486-257
SEI42C-486_FLAT_163		0.3281250	SEI42C-486-163	SEI42C-486_FLAT_258		0.8229170	SEI42C-486-258
SEI42C-486_FLAT_164	43	0.3333330	SEI42C-486-164	SEI42C-486_FLAT_259	91	0.8281250	SEI42C-486-259
SEI42C-486_FLAT_165		0.3385420	SEI42C-486-165	SEI42C-486_FLAT_260		0.8333330	SEI42C-486-260
SEI42C-486_FLAT_166	44	0.3437500	SEI42C-486-166	SEI42C-486_FLAT_261	92	0.8385420	SEI42C-486-261
SEI42C-486_FLAT_167		0.3489580	SEI42C-486-167	SEI42C-486_FLAT_262		0.8437500	SEI42C-486-262
SEI42C-486_FLAT_168	45	0.3541670	SEI42C-486-168	SEI42C-486_FLAT_263	93	0.8489580	SEI42C-486-263
SEI42C-486_FLAT_169		0.3593750	SEI42C-486-169	SEI42C-486_FLAT_264		0.8541670	SEI42C-486-264
SEI42C-486_FLAT_170	46	0.3645830	SEI42C-486-170	SEI42C-486_FLAT_265	94	0.8593750	SEI42C-486-265
SEI42C-486_FLAT_171		0.3697920	SEI42C-486-171	SEI42C-486_FLAT_266		0.8645830	SEI42C-486-266
SEI42C-486_FLAT_172	47	0.3750000	SEI42C-486-172	SEI42C-486_FLAT_267	95	0.8697920	SEI42C-486-267
SEI42C-486_FLAT_173		0.3802080	SEI42C-486-173	SEI42C-486_FLAT_268		0.8750000	SEI42C-486-268
	48			SEI42C-486_FLAT_269	96	0.8802080	SEI42C-486-269

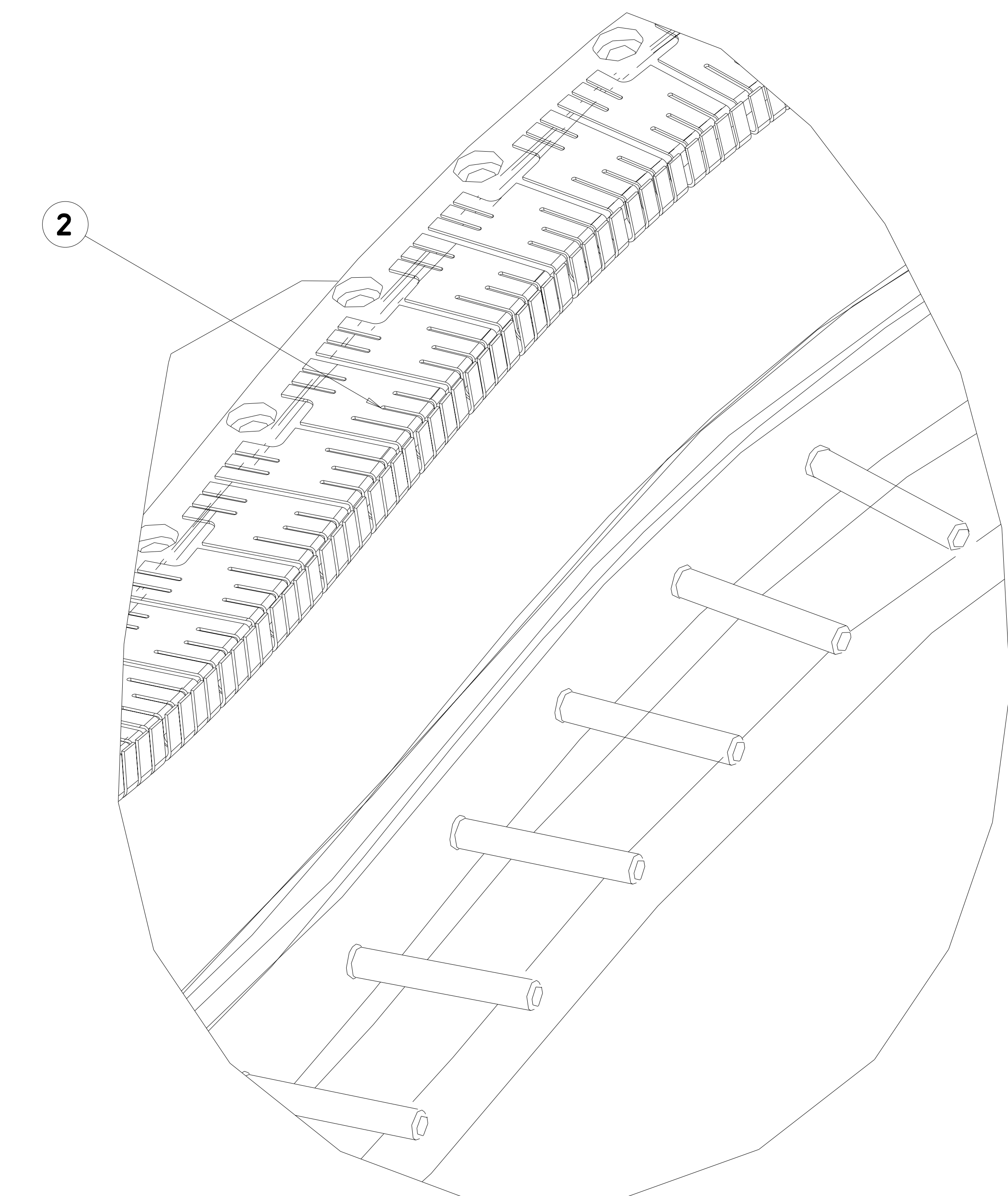

1 ISOMETRIC VIEW  
SCALE 1.00

AR	191	-2	CHILL PLATE PARTS	1	2
SEI42C-241	-1	-1	TYPE-C SIDE-B UPPER CHILL PLATE ASM		
		</			

1 THESE PARTS TO BE NEMA GRADE GIICR MATERIAL

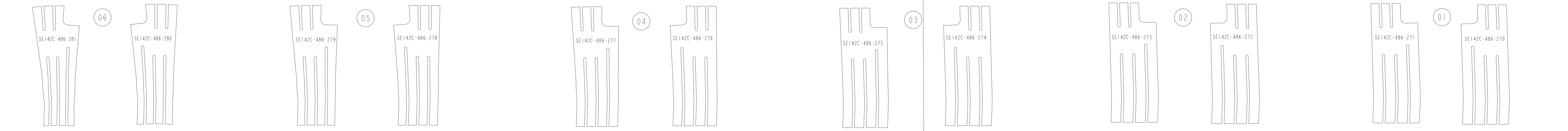

INSTANCE: SEI42C-486-281 INSTANCE: SEI42C-486-280 INSTANCE: SEI42C-486-279 INSTANCE: SEI42C-486-278 INSTANCE: SEI42C-486-277 INSTANCE: SEI42C-486-276 INSTANCE: SEI42C-486-275 INSTANCE: SEI42C-486-274 INSTANCE: SEI42C-486-273 INSTANCE: SEI42C-486-272 INSTANCE: SEI42C-486-271 INSTANCE: SEI42C-486-270

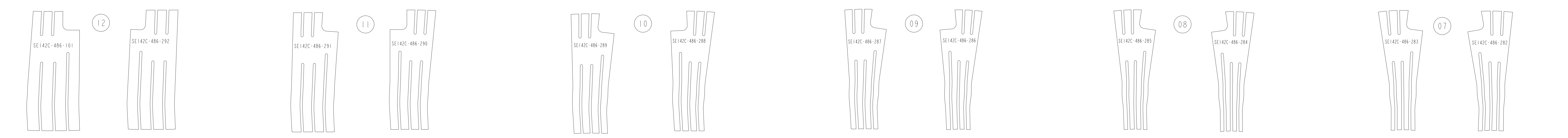

INSTANCE: SEI42C-486-101 INSTANCE: SEI42C-486-292 NEW INSTANCE: SEI42C-486-291 INSTANCE: SEI42C-486-290 INSTANCE: SEI42C-486-289 INSTANCE: SEI42C-486-288 INSTANCE: SEI42C-486-287 INSTANCE: SEI42C-486-286 INSTANCE: SEI42C-486-285 INSTANCE: SEI42C-486-284 INSTANCE: SEI42C-486-283 INSTANCE: SEI42C-486-282

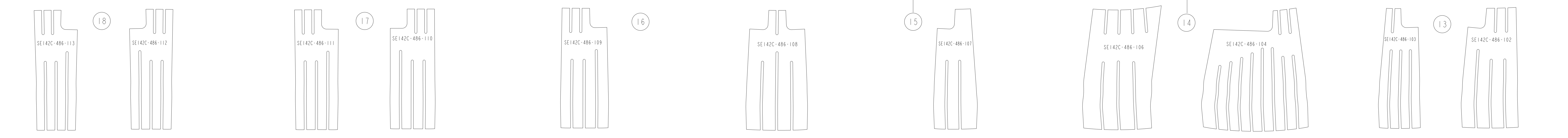

INSTANCE: SEI42C-486-113 INSTANCE: SEI42C-486-112 INSTANCE: SEI42C-486-111 INSTANCE: SEI42C-486-110 INSTANCE: SEI42C-486-109 INSTANCE: SEI42C-486-108 NEW INSTANCE: SEI42C-486-107 NEW INSTANCE: SEI42C-486-106 NEW INSTANCE: SEI42C-486-104 NEW INSTANCE: SEI42C-486-103 NEW INSTANCE: SEI42C-486-102



INSTANCE: SEI42C-486-125 INSTANCE: SEI42C-486-124 INSTANCE: SEI42C-486-123 INSTANCE: SEI42C-486-122 INSTANCE: SEI42C-486-121 INSTANCE: SEI42C-486-120 INSTANCE: SEI42C-486-119 INSTANCE: SEI42C-486-118 INSTANCE: SEI42C-486-117 INSTANCE: SEI42C-486-116 INSTANCE: SEI42C-486-115 INSTANCE: SEI42C-486-114

SCALE ALL VIEWS: 1.00

UT-BATTELLE		Oak Ridge National Laboratory managed for the DEPARTMENT OF ENERGY under U.S. GOVERNMENT CONTRACT DE-AC05-00OR22725 UT-BATTELLE, LLC. Oak Ridge, Tennessee	
PROJECT NAME			
<b>NATIONAL COMPACT STELLARATOR EXPERIMENT</b>			
<b>MODULAR COIL TYPE - C</b>			
<b>SIDE -B UPPER (TOP) CHILL PLATES</b>			
<b>FLAT PATTERN LAYOUT</b>			
VERSION NO.	PLANT	BLDG	FL SHT OF TYPE CLASS
3+	X-10	5700	3 2 5 S U
RELEASE LEVEL		SEI42C-486	
WIP		REV I	

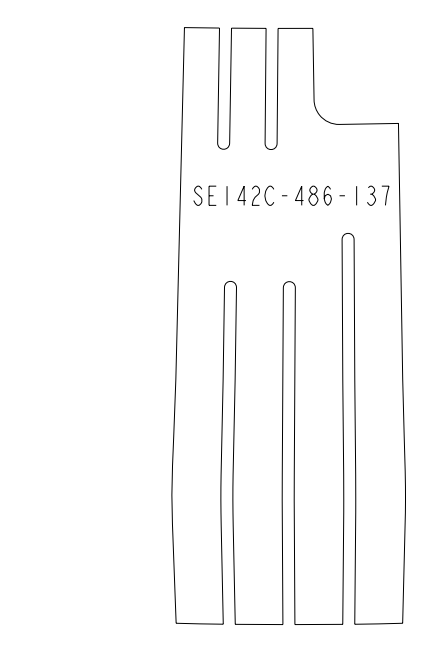

INSTANCE:  
SE142C-486\_FLAT\_137

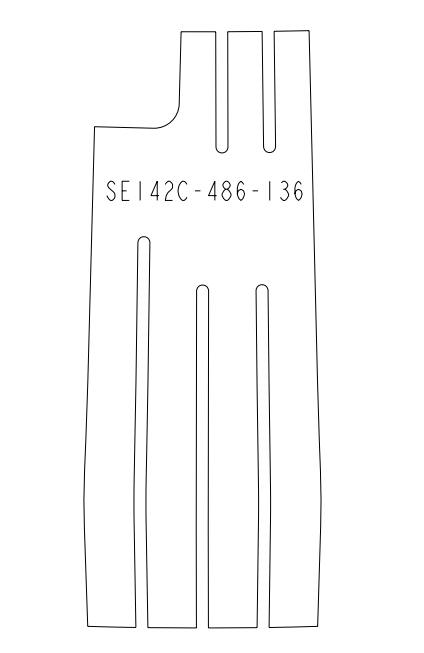

INSTANCE:  
SE142C-486\_FLAT\_136

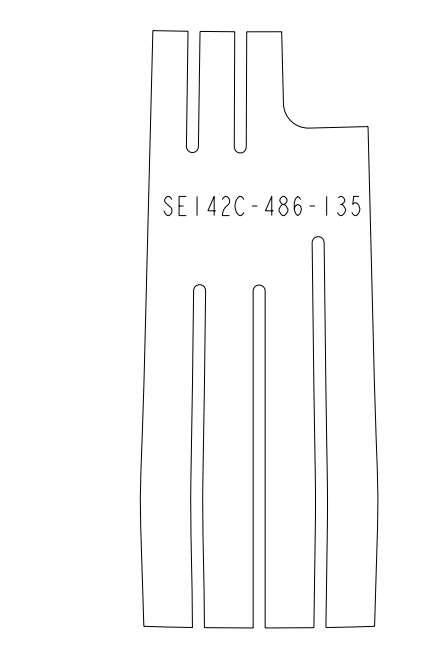

INSTANCE:  
SE142C-486\_FLAT\_135

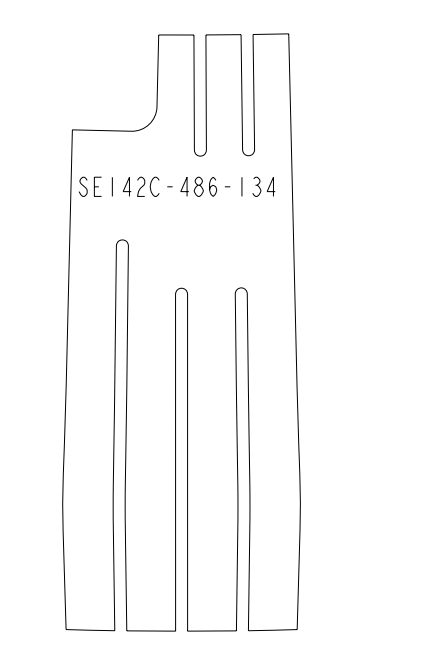

INSTANCE:  
SE142C-486\_FLAT\_134

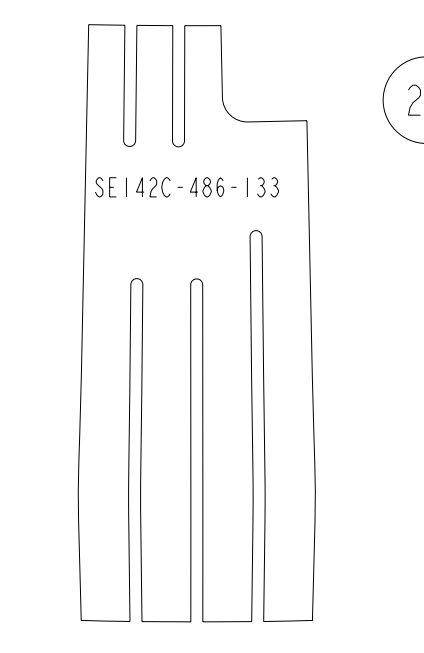

INSTANCE:  
SE142C-486\_FLAT\_133

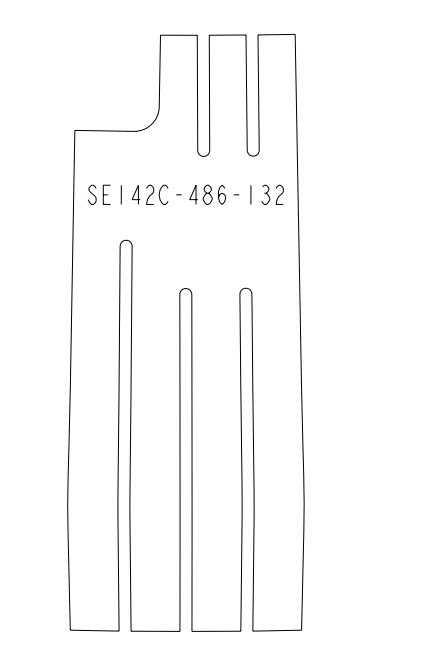

INSTANCE:  
SE142C-486\_FLAT\_132

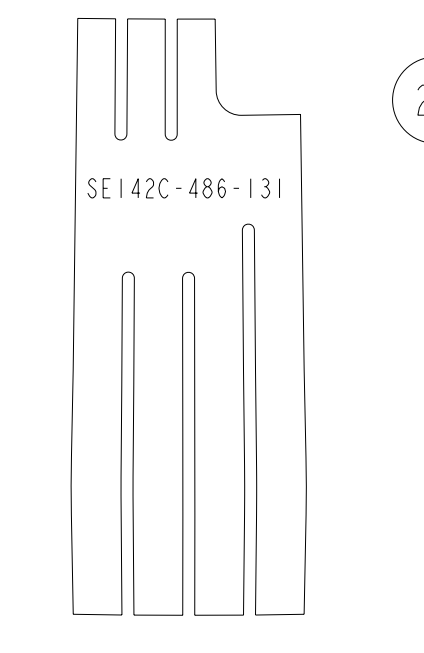

INSTANCE:  
SE142C-486\_FLAT\_131

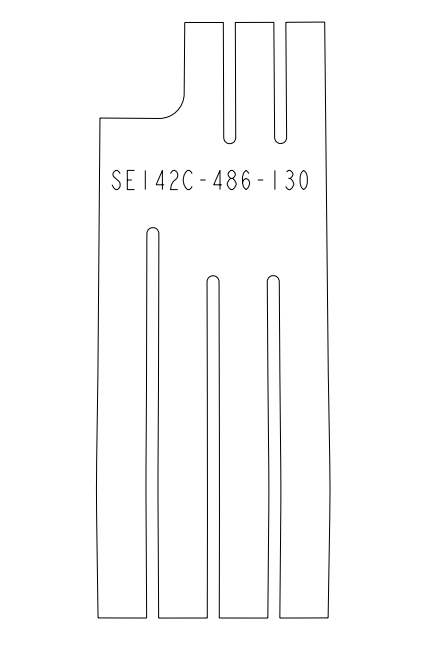

INSTANCE:  
SE142C-486\_FLAT\_130

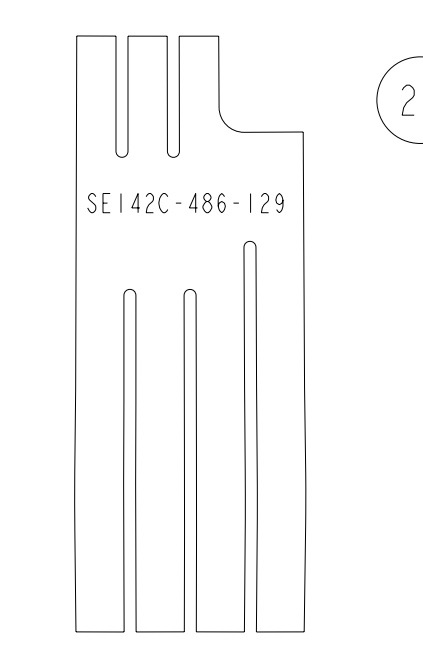

INSTANCE:  
SE142C-486\_FLAT\_129

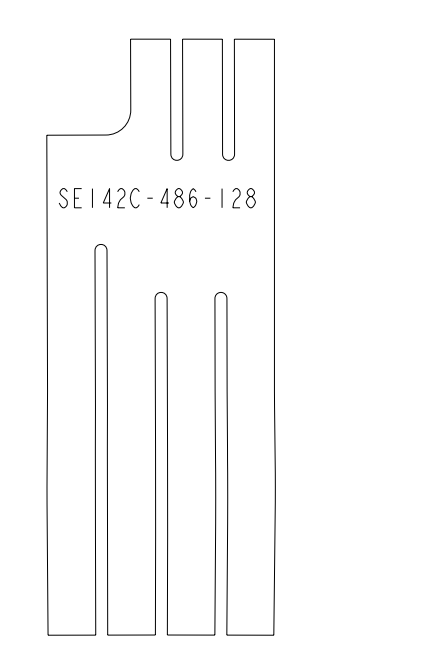

INSTANCE:  
SE142C-486\_FLAT\_128

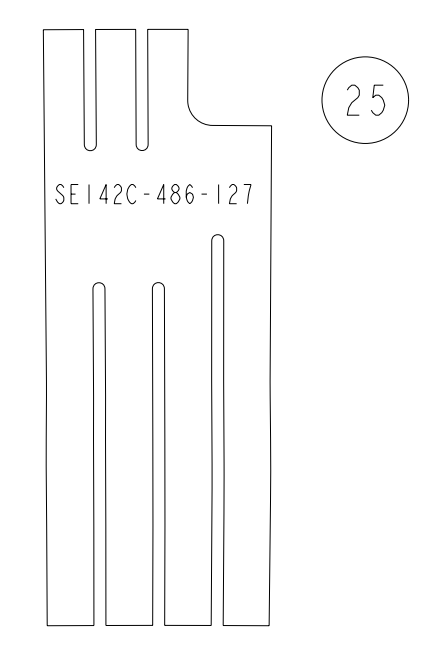

INSTANCE:  
SE142C-486\_FLAT\_127

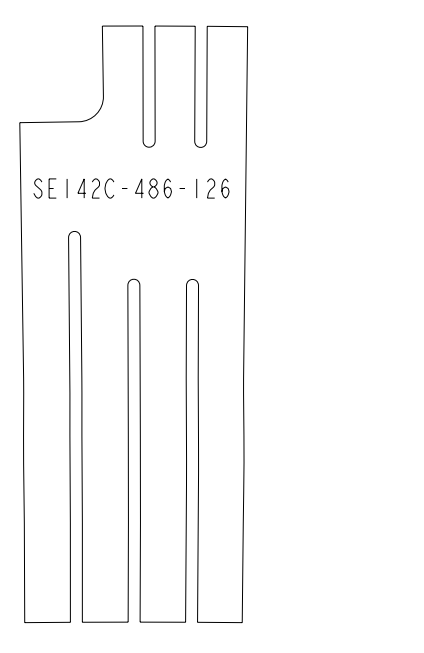

INSTANCE:  
SE142C-486\_FLAT\_126

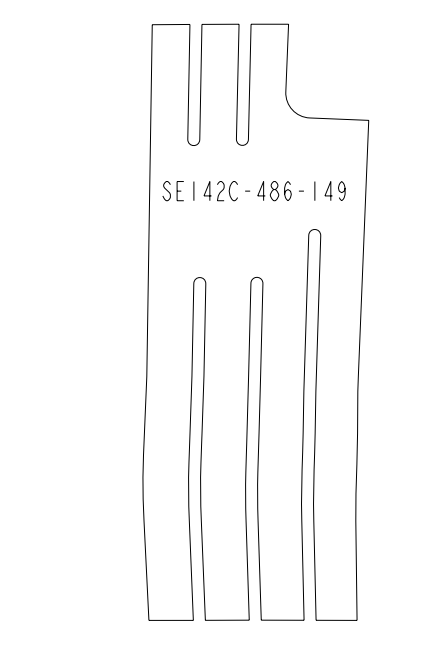

INSTANCE:  
SE142C-486\_FLAT\_149

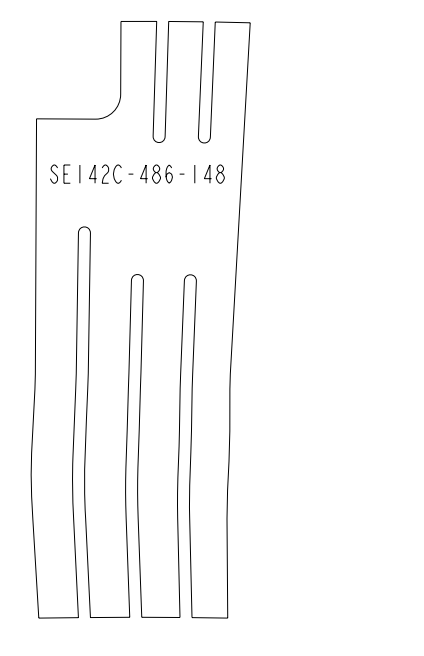

INSTANCE:  
SE142C-486\_FLAT\_148

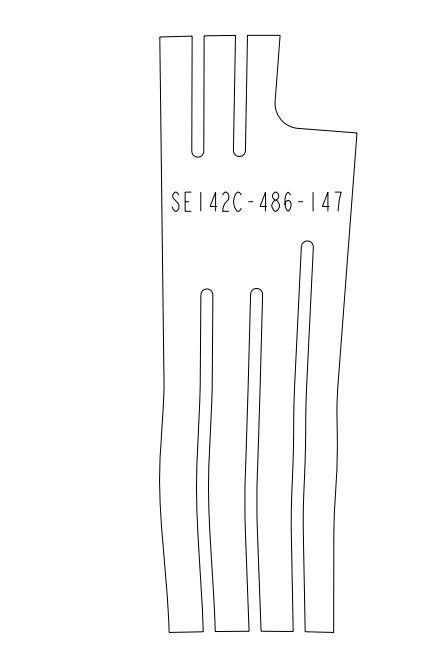

INSTANCE:  
SE142C-486\_FLAT\_147

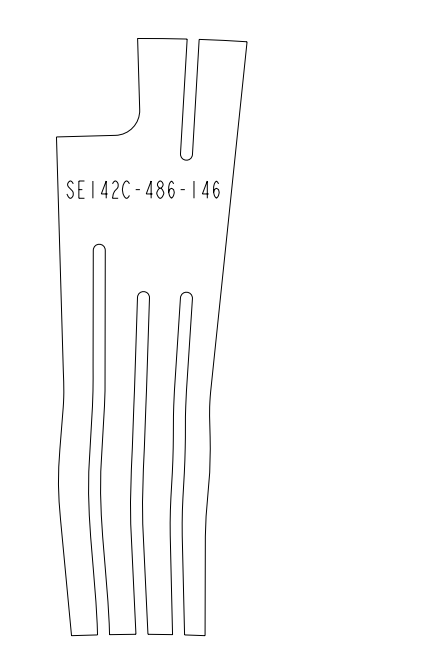

INSTANCE:  
SE142C-486\_FLAT\_146-NEW

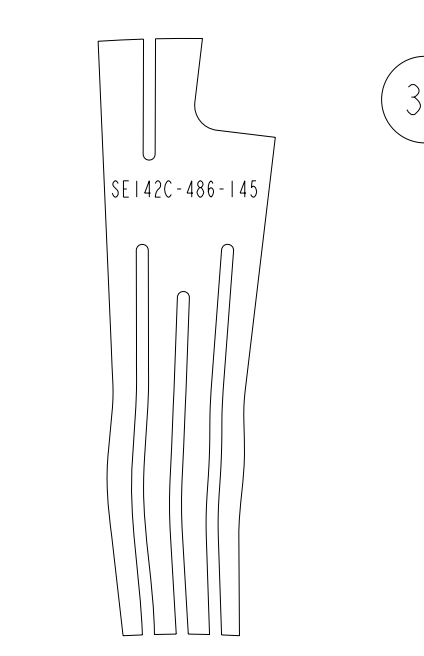

INSTANCE:  
SE142C-486\_FLAT\_145-NEW

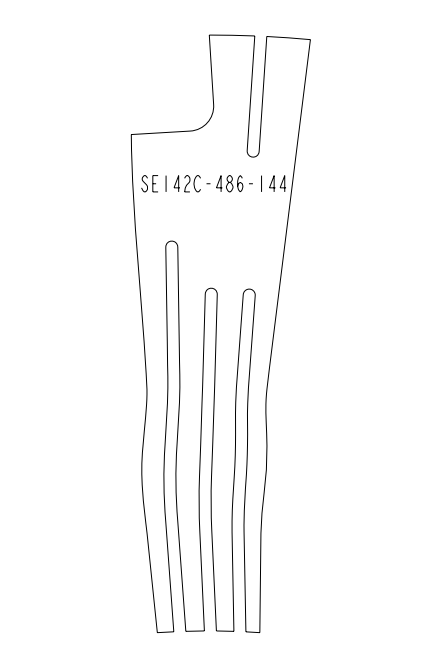

INSTANCE:  
SE142C-486\_FLAT\_144-NEW

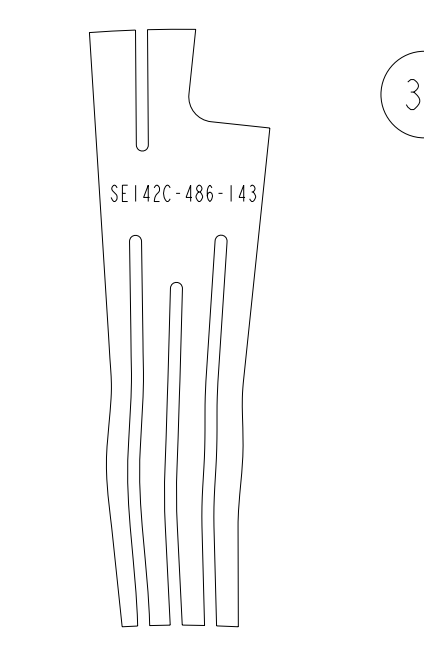

INSTANCE:  
SE142C-486\_FLAT\_143-NEW

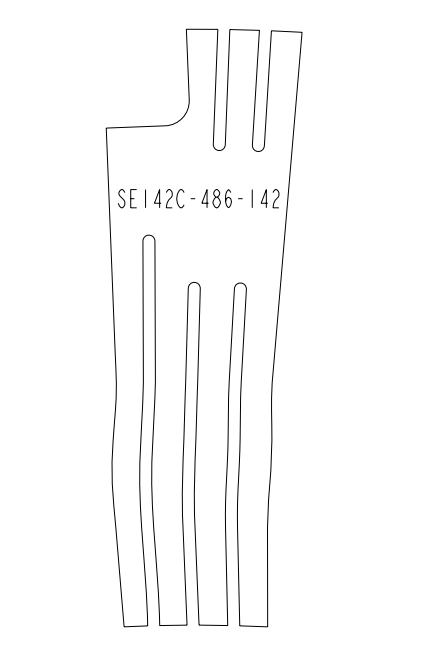

INSTANCE:  
SE142C-486\_FLAT\_142

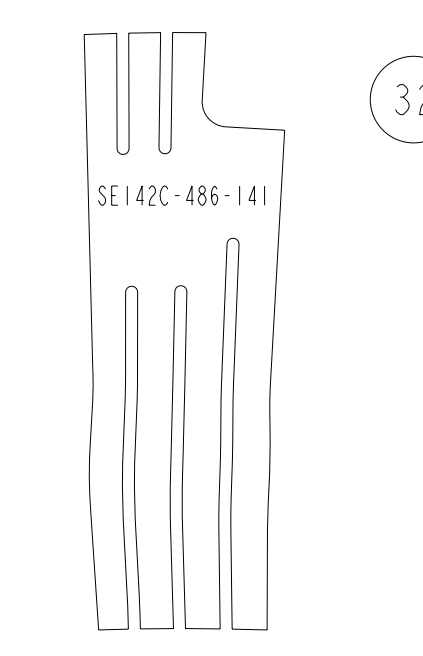

INSTANCE:  
SE142C-486\_FLAT\_141

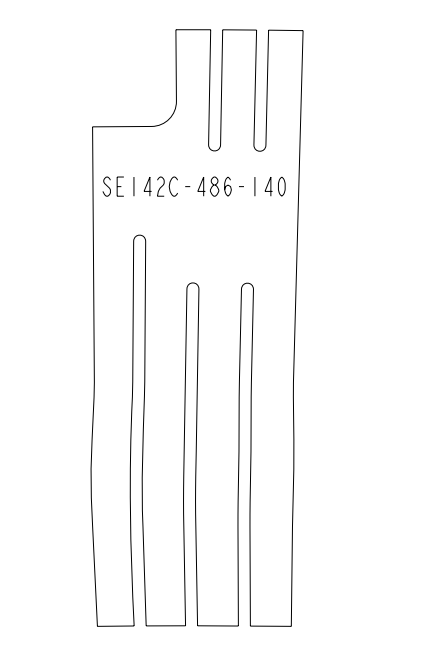

INSTANCE:  
SE142C-486\_FLAT\_140

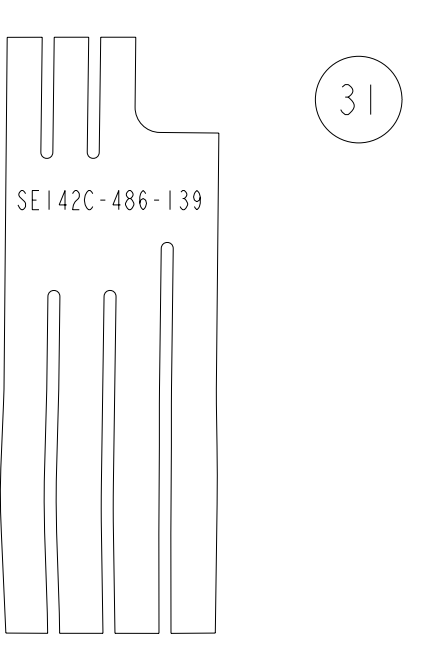

INSTANCE:  
SE142C-486\_FLAT\_139

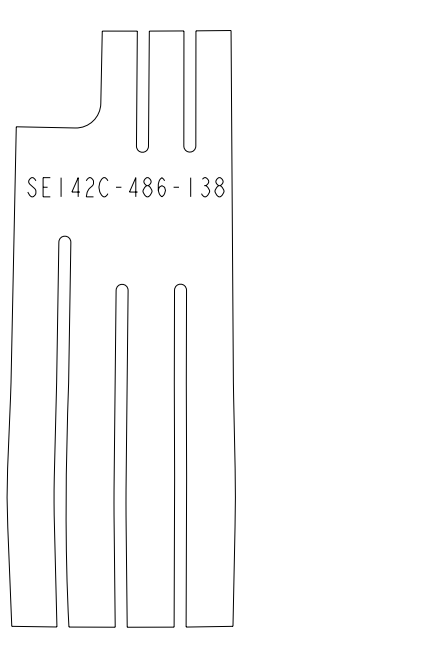

INSTANCE:  
SE142C-486\_FLAT\_138

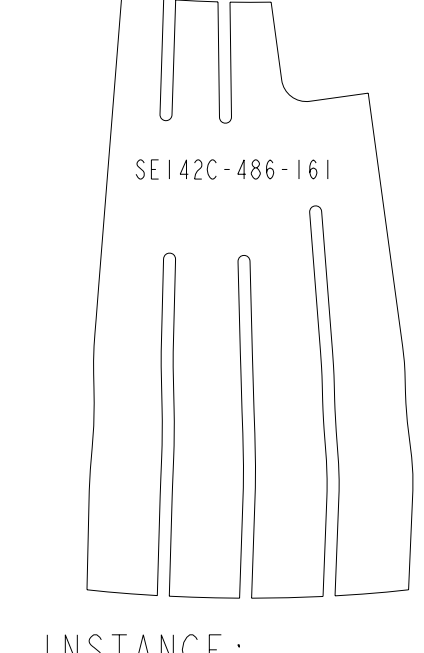

INSTANCE:  
SE142C-486\_FLAT\_161

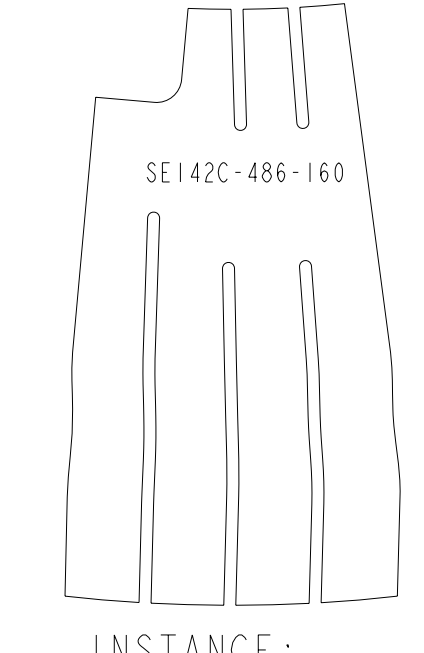

INSTANCE:  
SE142C-486\_FLAT\_160

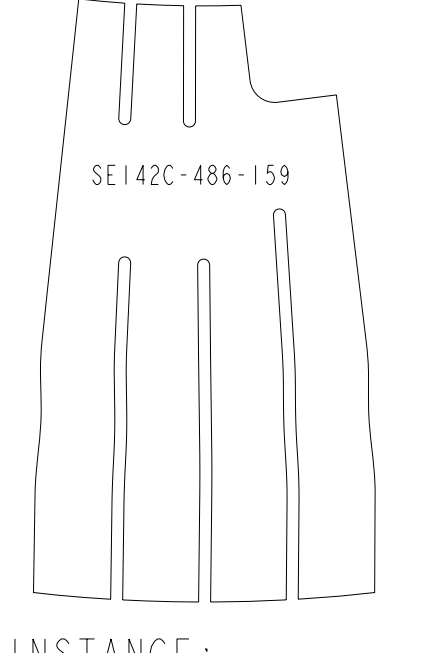

INSTANCE:  
SE142C-486\_FLAT\_159

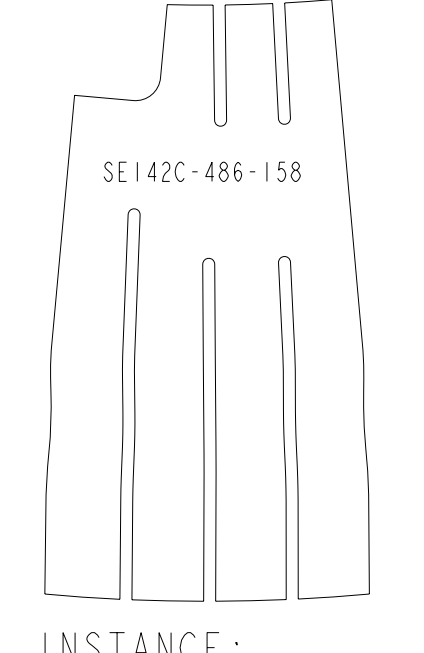

INSTANCE:  
SE142C-486\_FLAT\_158

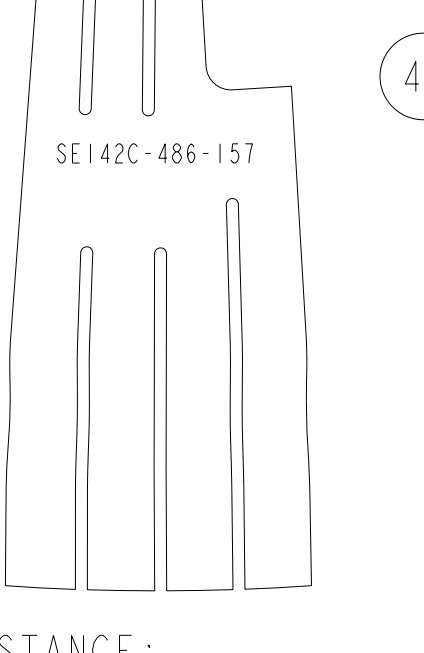

INSTANCE:  
SE142C-486\_FLAT\_157

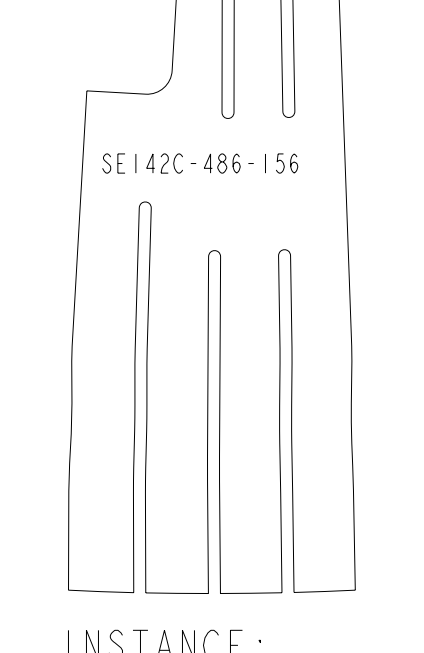

INSTANCE:  
SE142C-486\_FLAT\_156

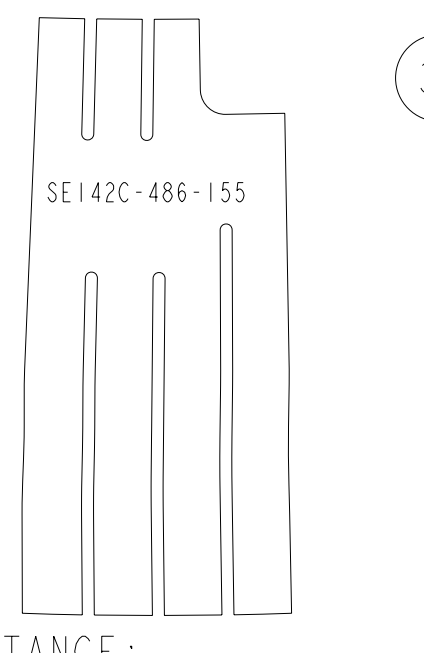

INSTANCE:  
SE142C-486\_FLAT\_155

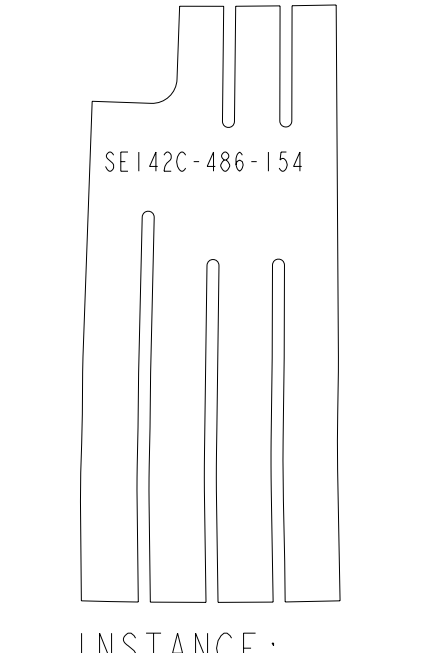

INSTANCE:  
SE142C-486\_FLAT\_154

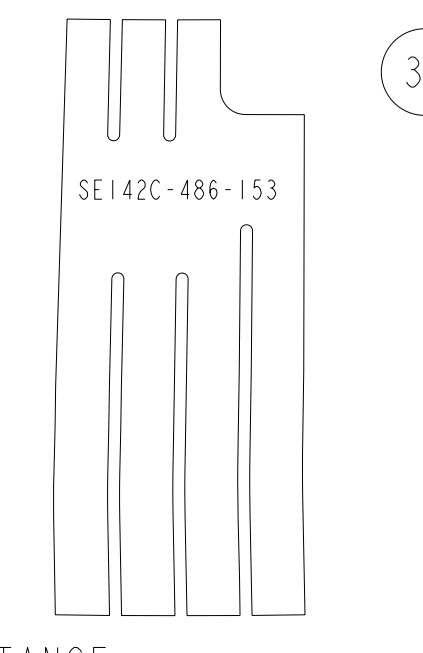

INSTANCE:  
SE142C-486\_FLAT\_153

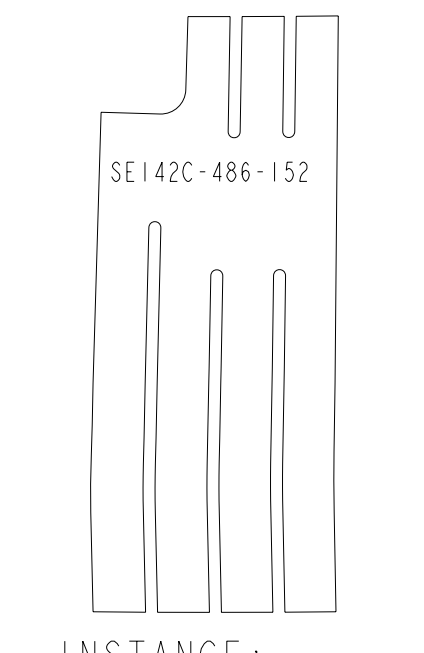

INSTANCE:  
SE142C-486\_FLAT\_152

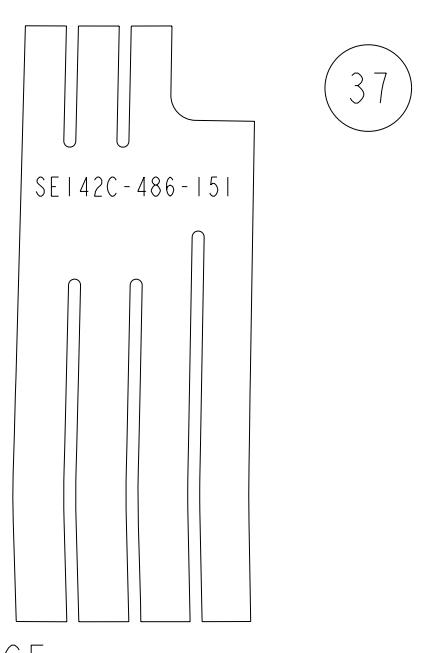

INSTANCE:  
SE142C-486\_FLAT\_151

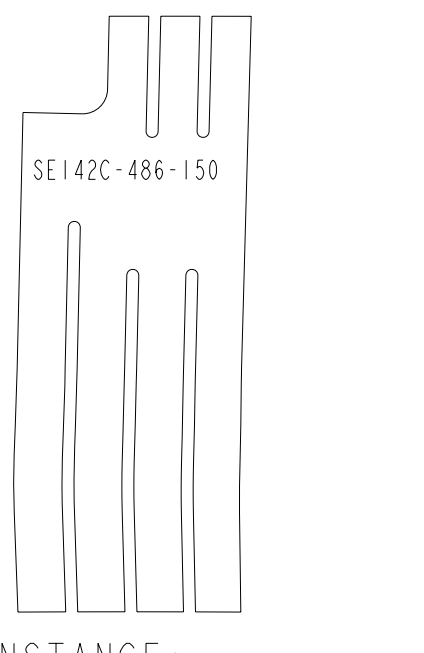

INSTANCE:  
SE142C-486\_FLAT\_150

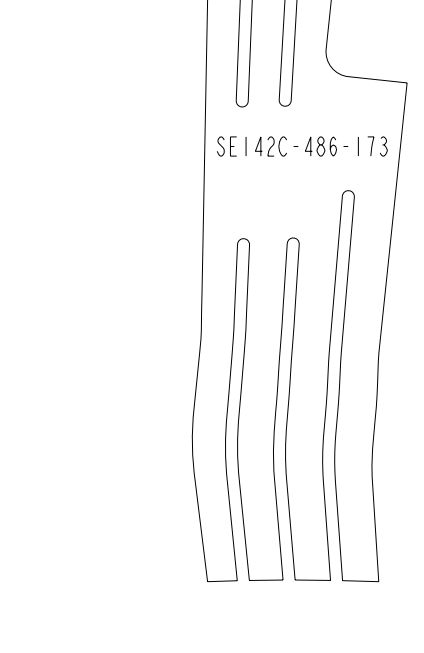

INSTANCE:  
SE142C-486\_FLAT\_173

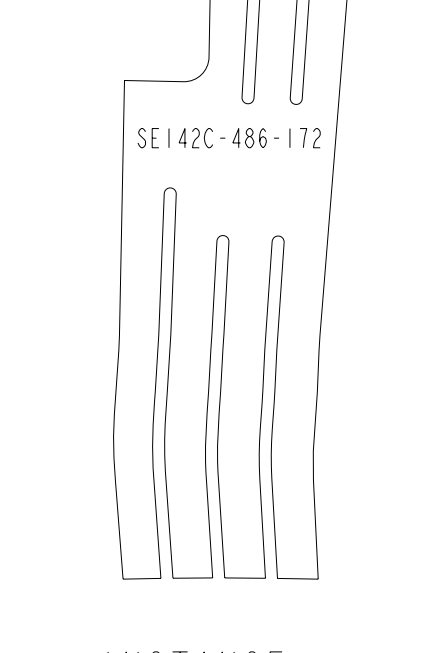

INSTANCE:  
SE142C-486\_FLAT\_172

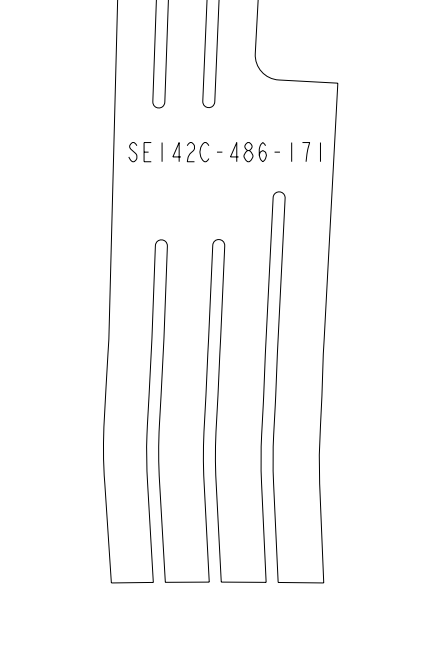

INSTANCE:  
SE142C-486\_FLAT\_171

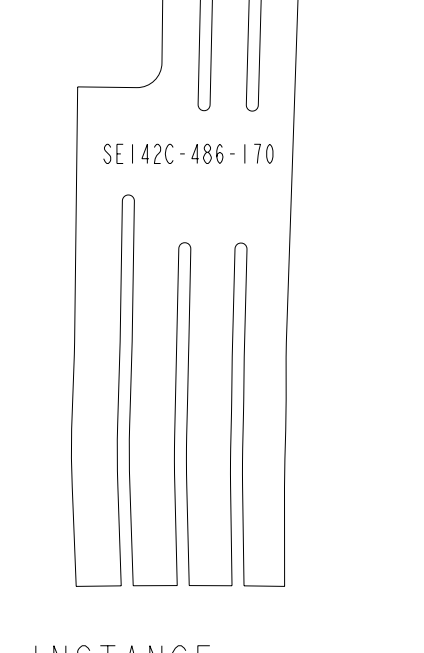

INSTANCE:  
SE142C-486\_FLAT\_170

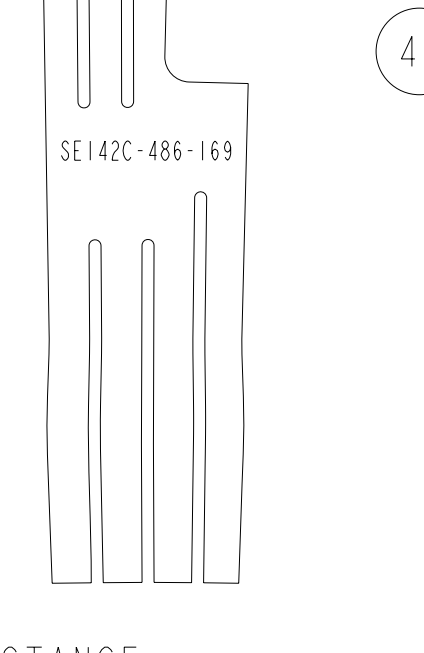

INSTANCE:  
SE142C-486\_FLAT\_169

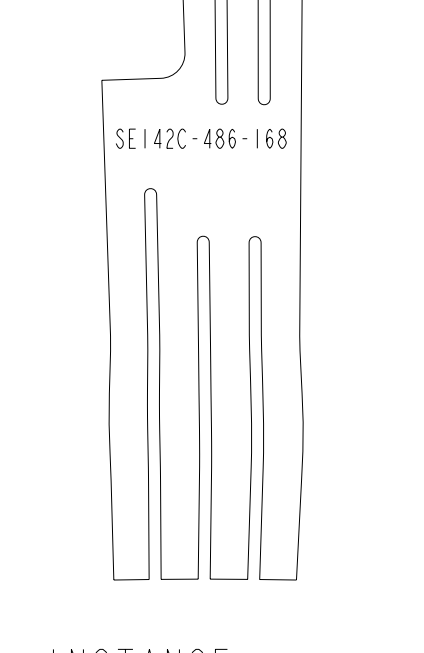

INSTANCE:  
SE142C-486\_FLAT\_168

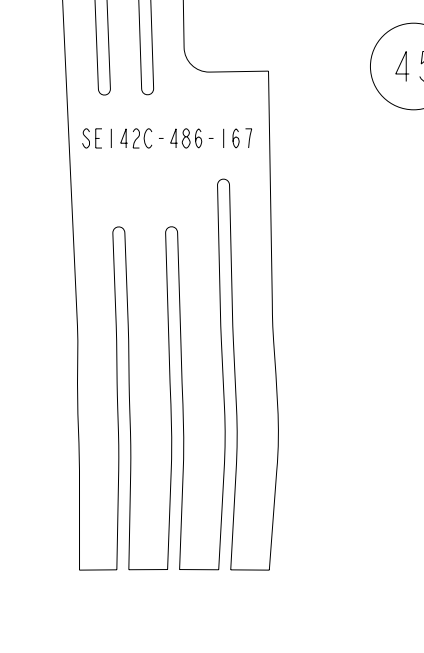

INSTANCE:  
SE142C-486\_FLAT\_167

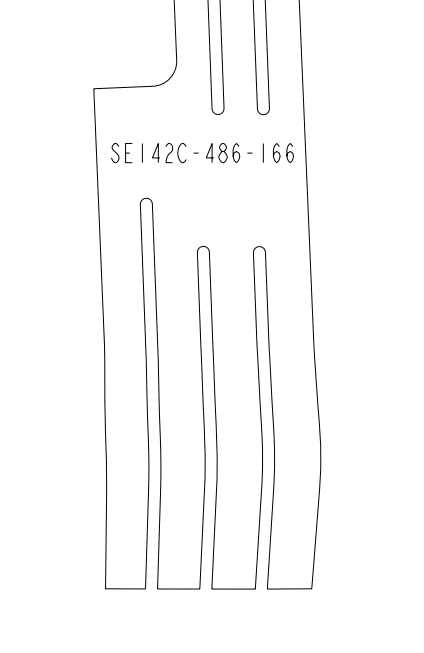

INSTANCE:  
SE142C-486\_FLAT\_166

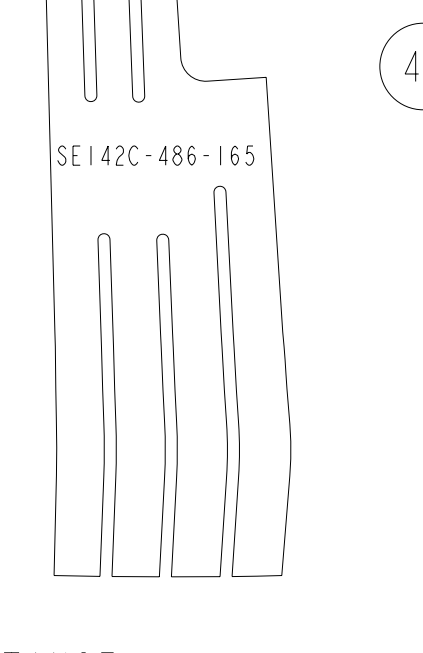

INSTANCE:  
SE142C-486\_FLAT\_165

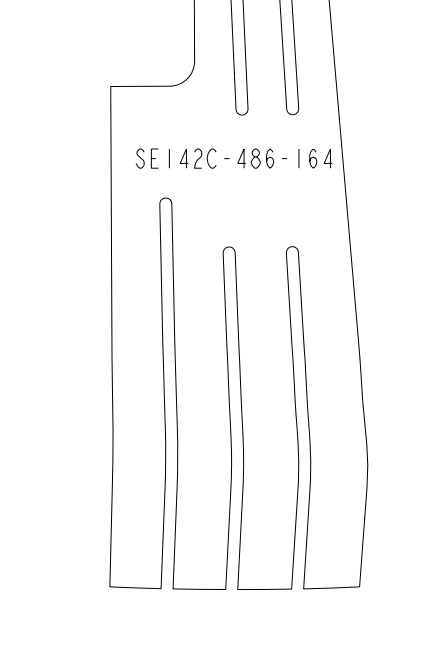

INSTANCE:  
SE142C-486\_FLAT\_164

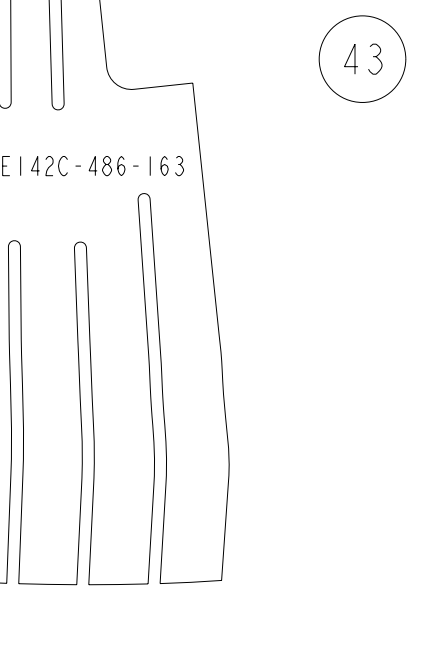

INSTANCE:  
SE142C-486\_FLAT\_163

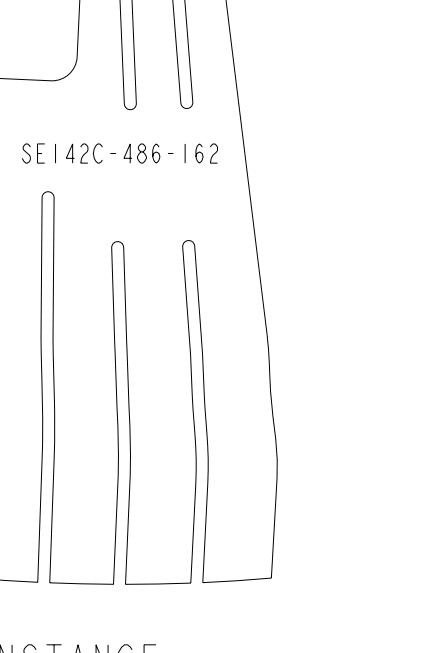

INSTANCE:  
SE142C-486\_FLAT\_162

SCALE ALL VIEWS: 1.00

UT-BATTELLE		Oak Ridge National Laboratory managed for the DEPARTMENT OF ENERGY under U.S. GOVERNMENT CONTRACT DE-AC05-00OR22725 UT-BATTELLE, LLC., Oak Ridge, Tennessee	
PROJECT NAME			
NATIONAL COMPACT STELLARATOR EXPERIMENT			
MODULAR COIL TYPE - C			
SIDE -B UPPER (TOP) CHILL PLATES			
FLAT PATTERN LAYOUT			
VERSION NO.	PLANT	BLDG	FL SHT OF TYPE CLASS
3+	X-10	5700	3 3 5 S U
RELEASE LEVEL		SE142C-486	
WIP		REV I	

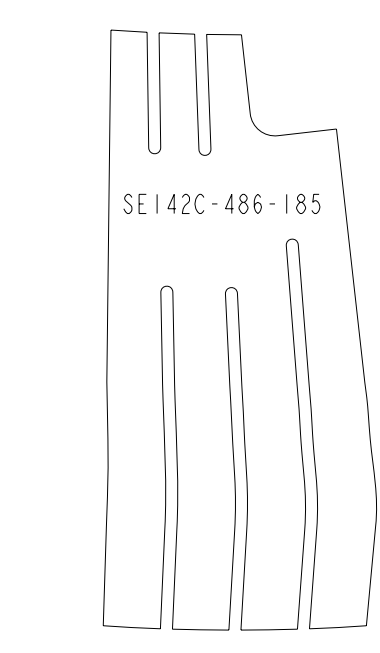
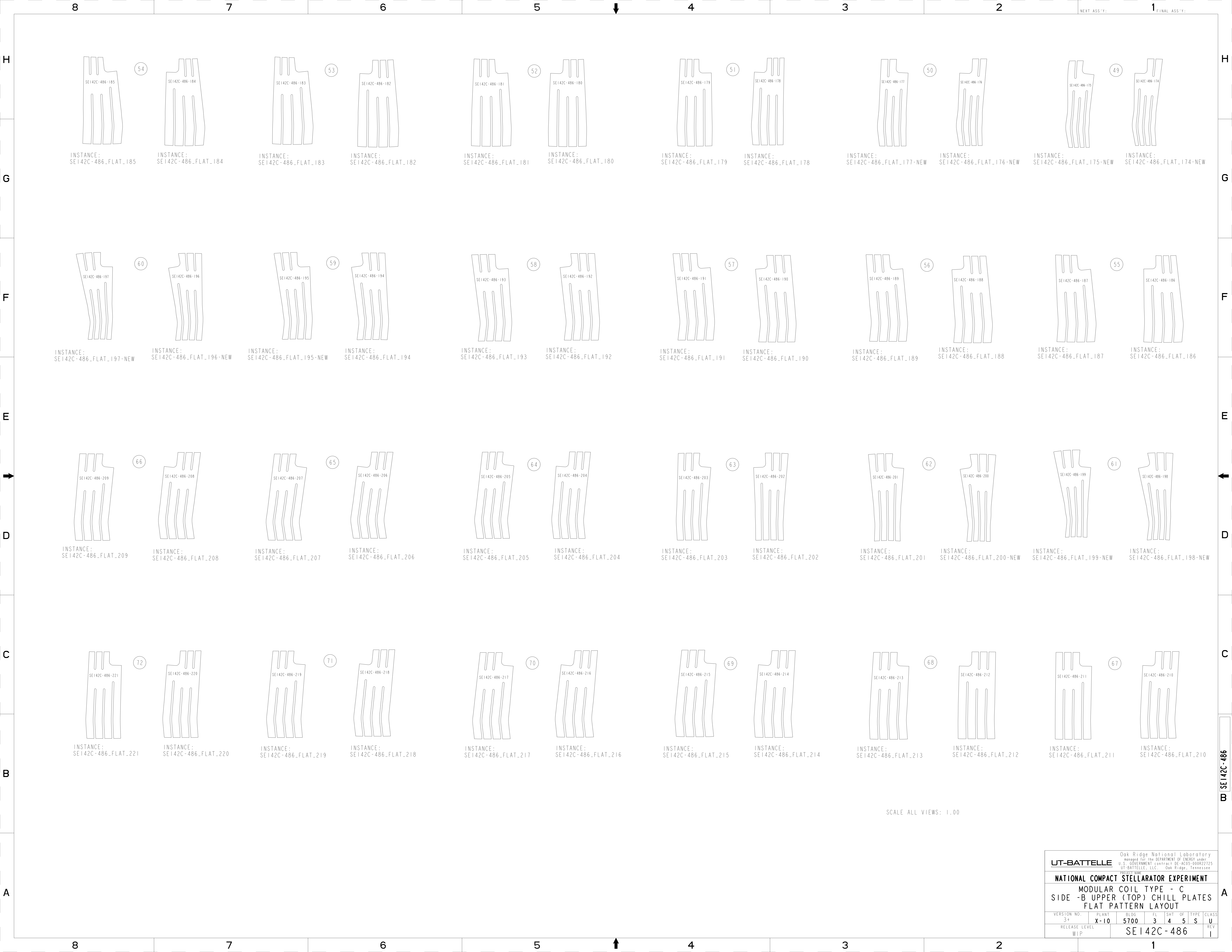

INSTANCE:  
SEI42C-486\_FLAT\_185

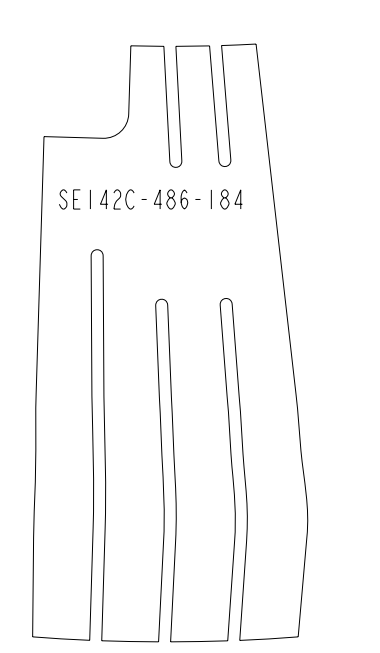

INSTANCE:  
SEI42C-486\_FLAT\_184

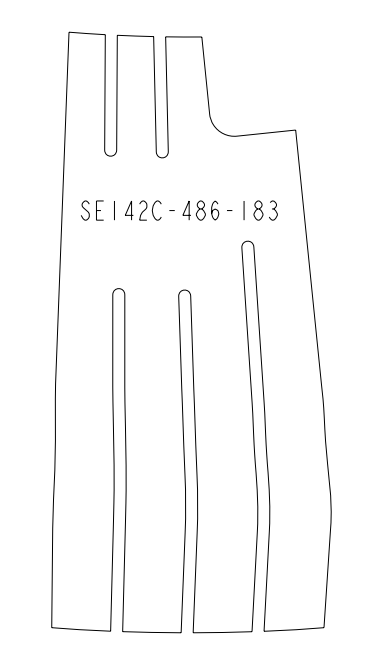

INSTANCE:  
SEI42C-486\_FLAT\_183

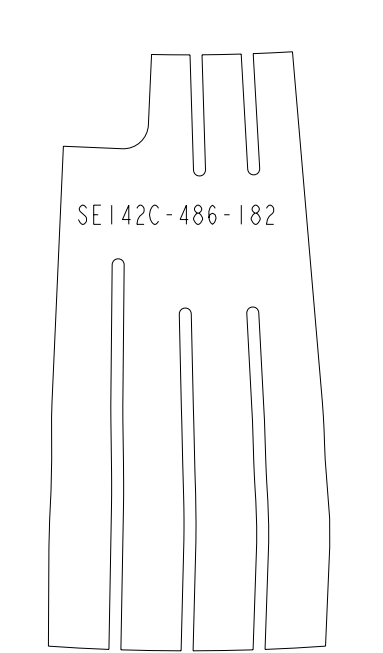

INSTANCE:  
SEI42C-486\_FLAT\_182

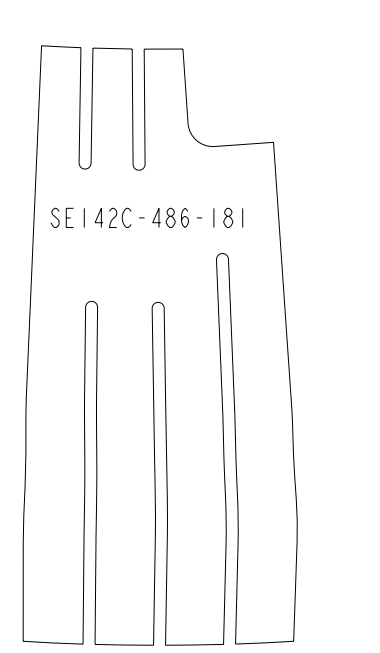

INSTANCE:  
SEI42C-486\_FLAT\_181

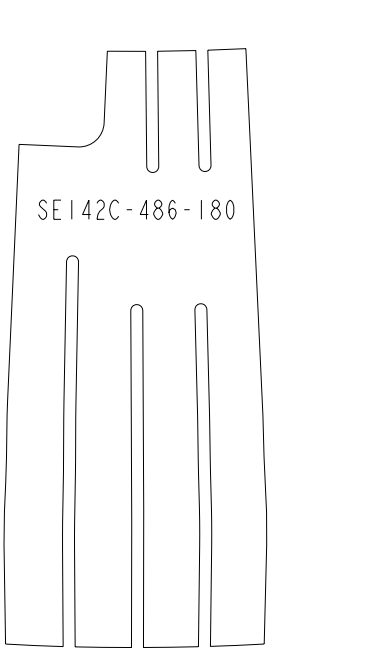

INSTANCE:  
SEI42C-486\_FLAT\_180

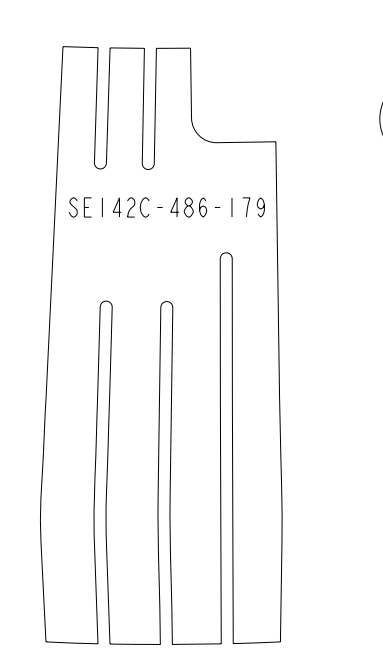

INSTANCE:  
SEI42C-486\_FLAT\_179

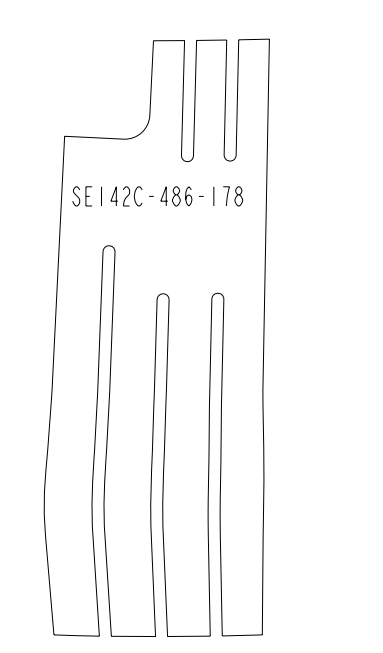

INSTANCE:  
SEI42C-486\_FLAT\_178

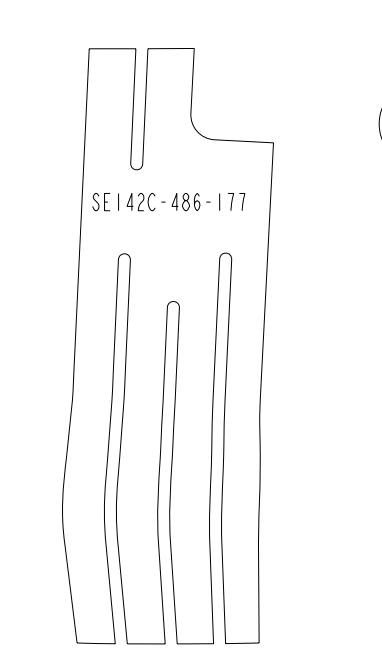

INSTANCE:  
SEI42C-486\_FLAT\_177-NEW

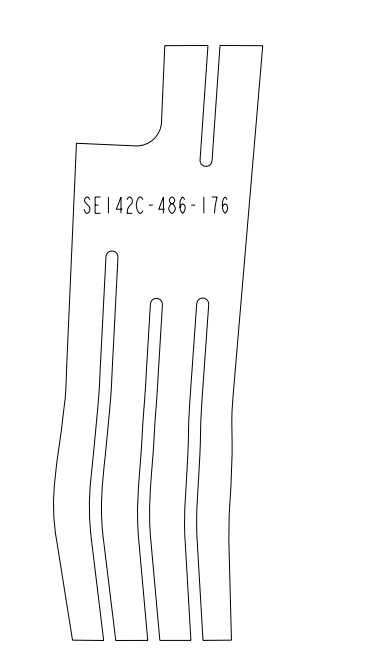

INSTANCE:  
SEI42C-486\_FLAT\_176-NEW

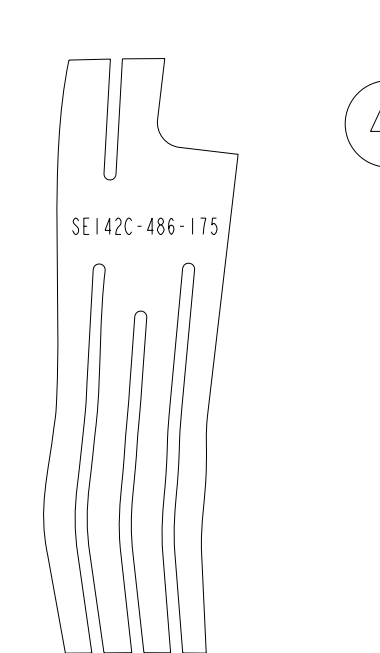

INSTANCE:  
SEI42C-486\_FLAT\_175-NEW

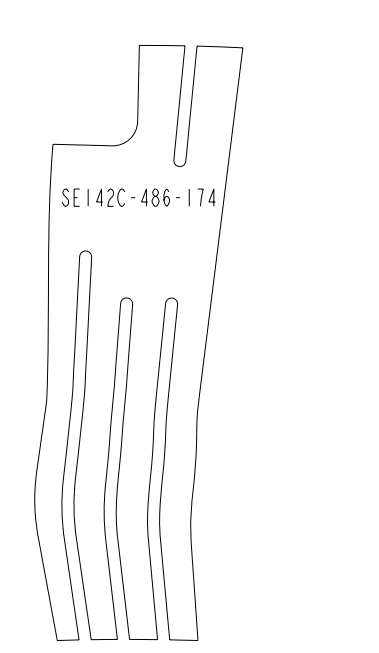

INSTANCE:  
SEI42C-486\_FLAT\_174-NEW

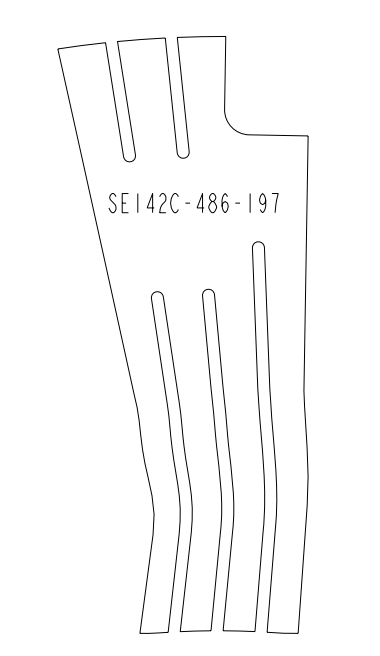

INSTANCE:  
SEI42C-486\_FLAT\_197-NEW

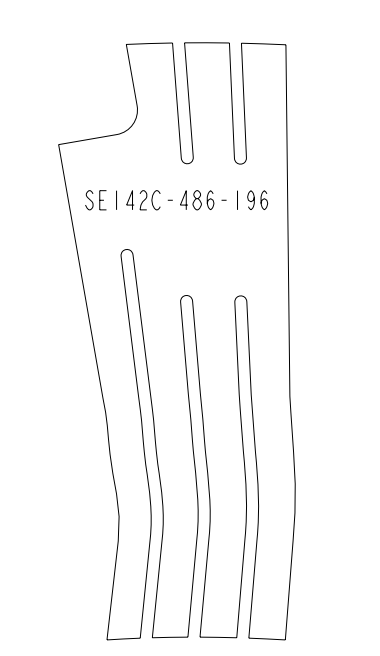

INSTANCE:  
SEI42C-486\_FLAT\_196-NEW

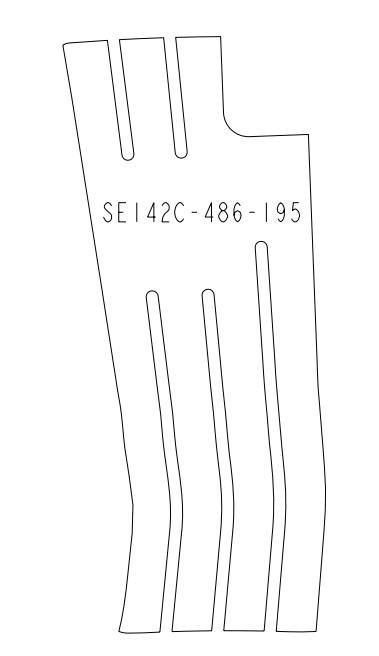

INSTANCE:  
SEI42C-486\_FLAT\_195-NEW

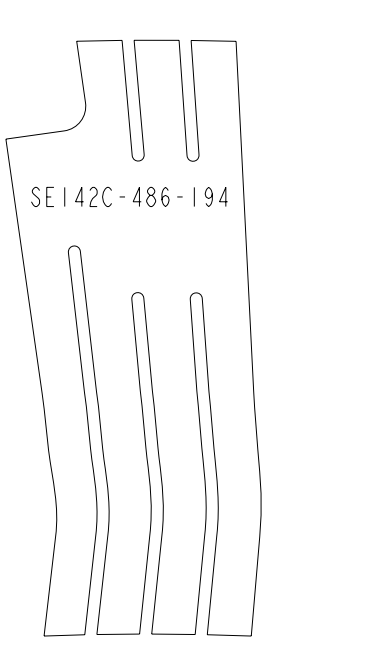

INSTANCE:  
SEI42C-486\_FLAT\_194

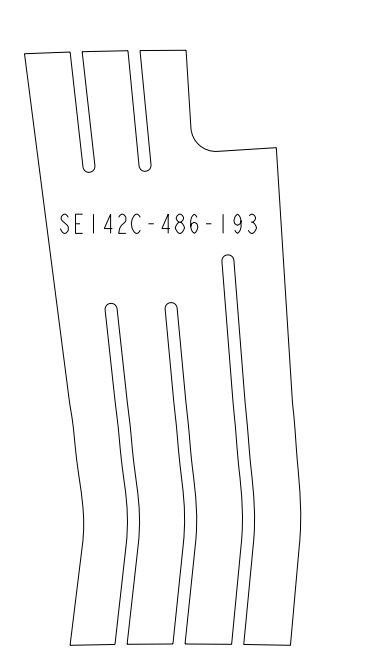

INSTANCE:  
SEI42C-486\_FLAT\_193

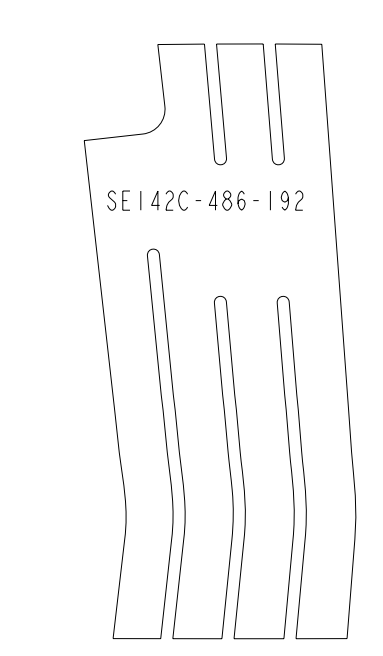

INSTANCE:  
SEI42C-486\_FLAT\_192

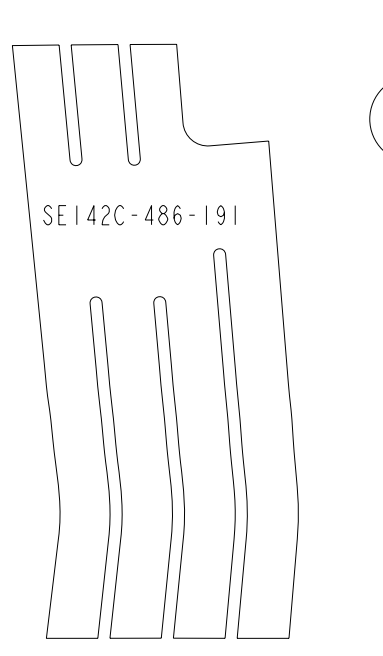

INSTANCE:  
SEI42C-486\_FLAT\_191

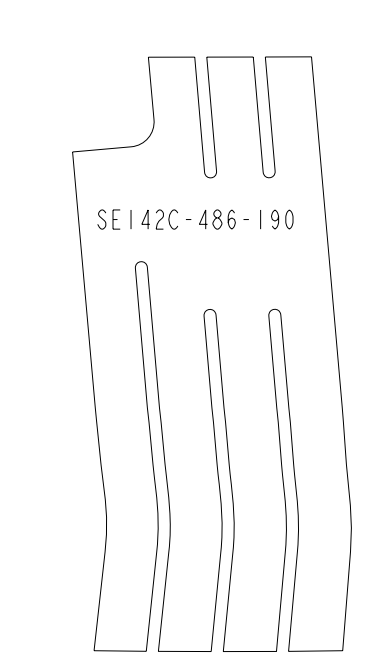

INSTANCE:  
SEI42C-486\_FLAT\_190

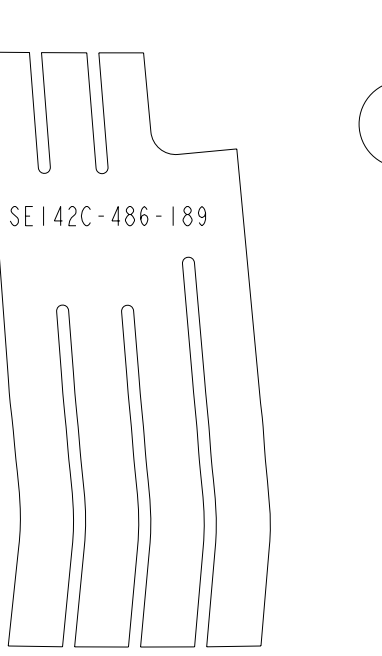

INSTANCE:  
SEI42C-486\_FLAT\_189

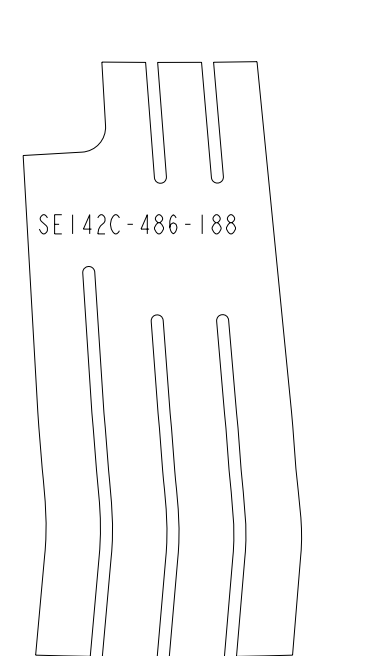

INSTANCE:  
SEI42C-486\_FLAT\_188

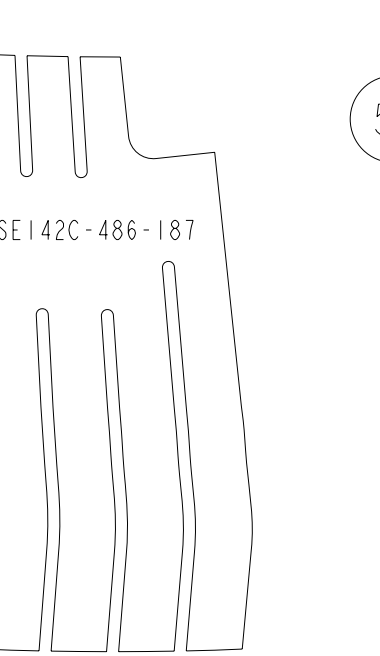

INSTANCE:  
SEI42C-486\_FLAT\_187

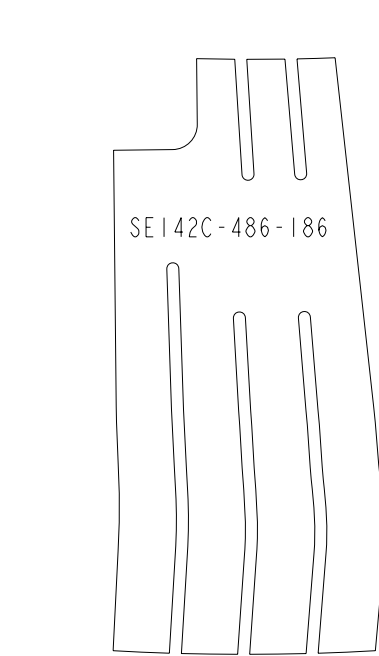

INSTANCE:  
SEI42C-486\_FLAT\_186

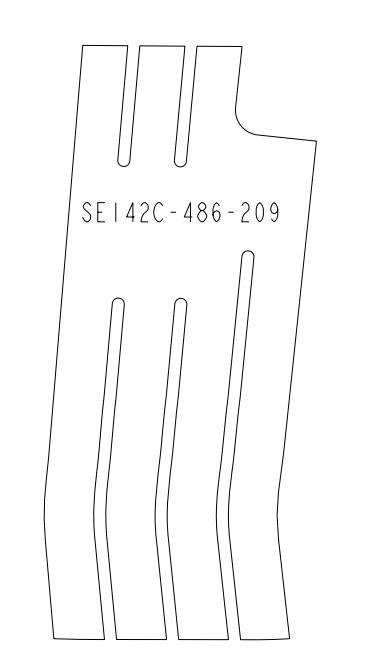

INSTANCE:  
SEI42C-486\_FLAT\_209

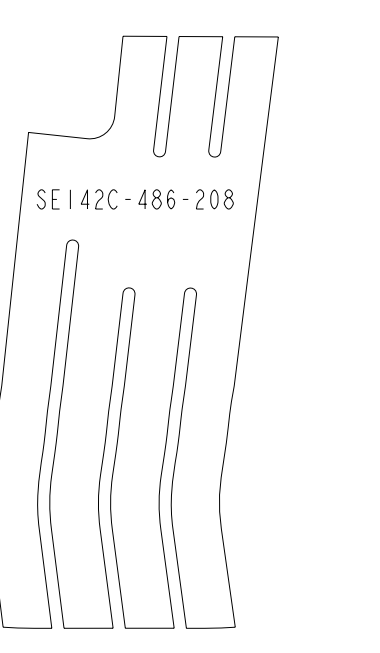

INSTANCE:  
SEI42C-486\_FLAT\_208

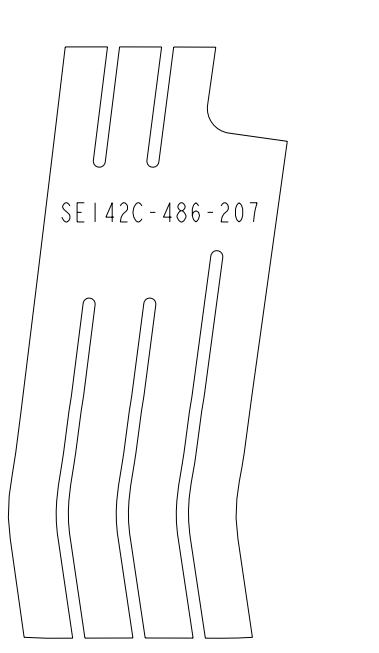

INSTANCE:  
SEI42C-486\_FLAT\_207

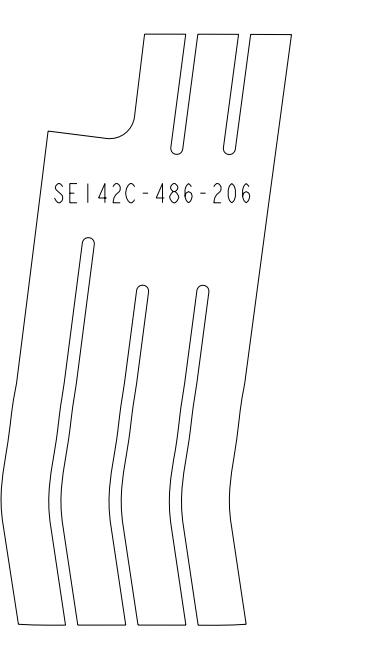

INSTANCE:  
SEI42C-486\_FLAT\_206

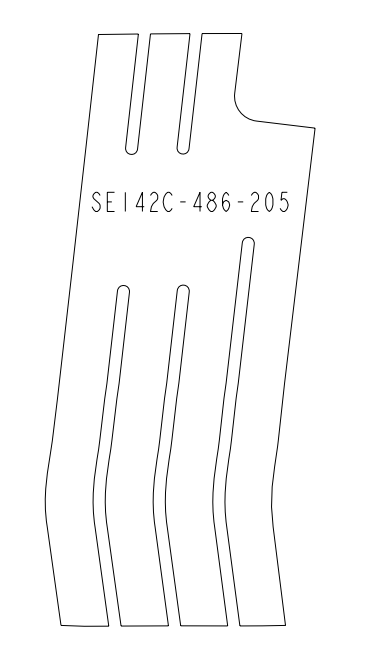

INSTANCE:  
SEI42C-486\_FLAT\_205

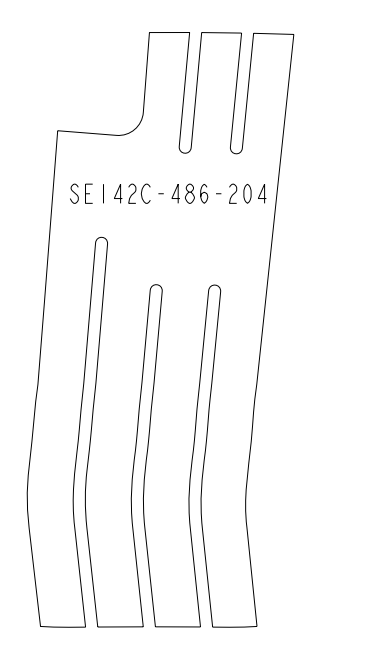

INSTANCE:  
SEI42C-486\_FLAT\_204

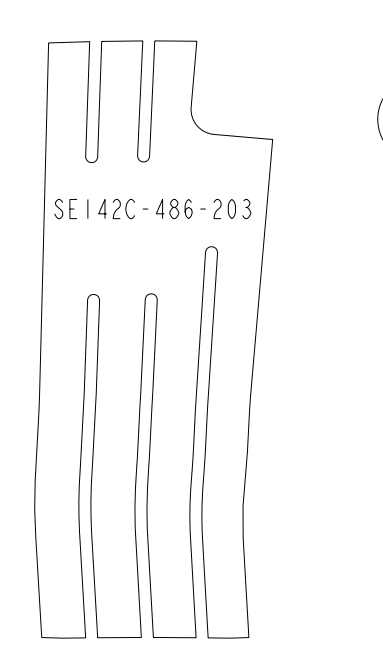

INSTANCE:  
SEI42C-486\_FLAT\_203

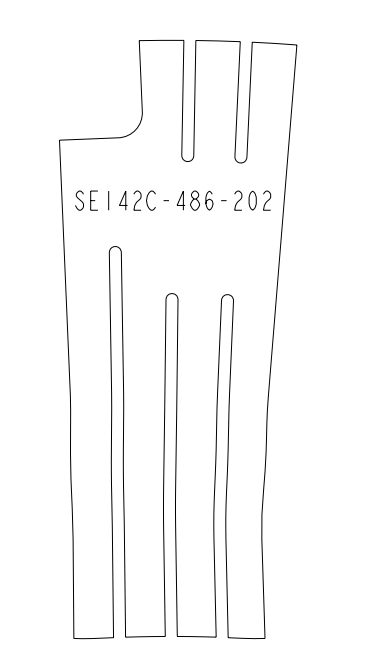

INSTANCE:  
SEI42C-486\_FLAT\_202

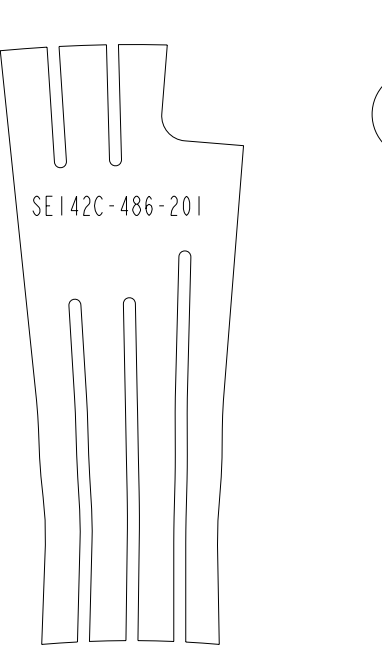

INSTANCE:  
SEI42C-486\_FLAT\_201

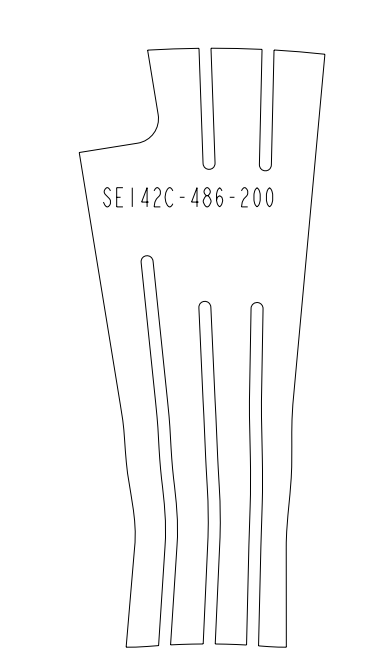

INSTANCE:  
SEI42C-486\_FLAT\_200-NEW

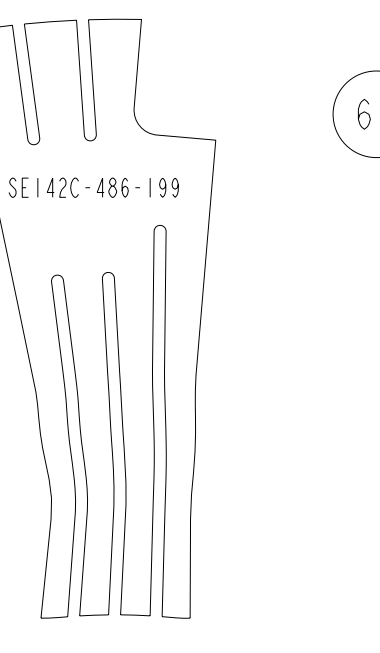

INSTANCE:  
SEI42C-486\_FLAT\_199-NEW

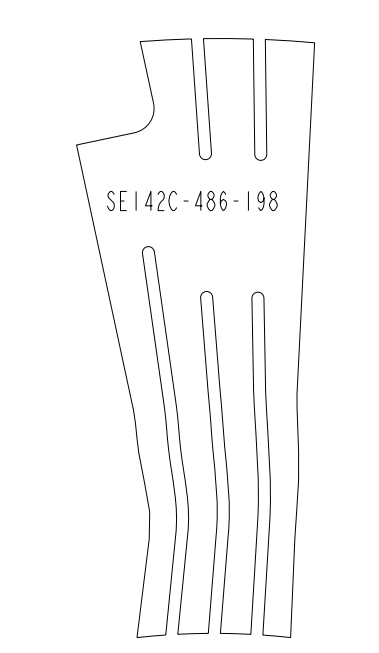

INSTANCE:  
SEI42C-486\_FLAT\_198-NEW

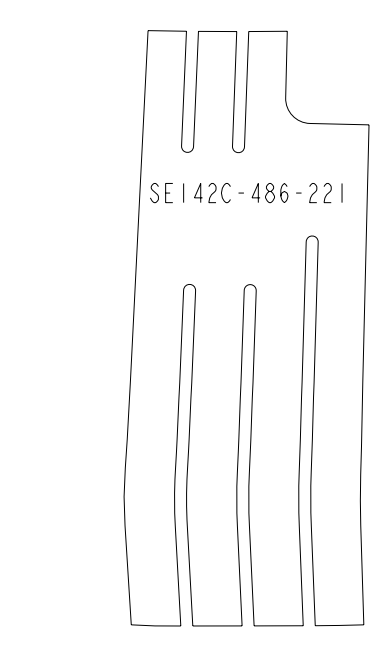

INSTANCE:  
SEI42C-486\_FLAT\_221

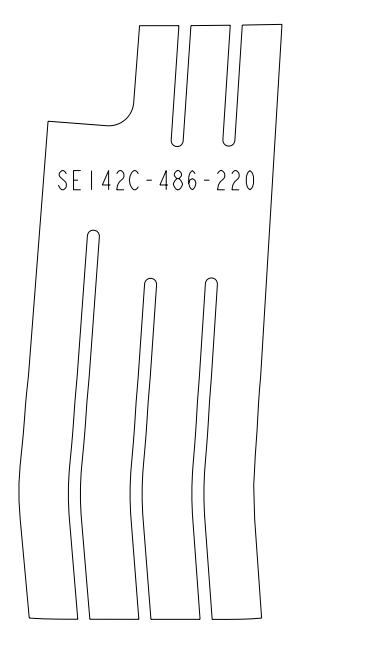

INSTANCE:  
SEI42C-486\_FLAT\_220

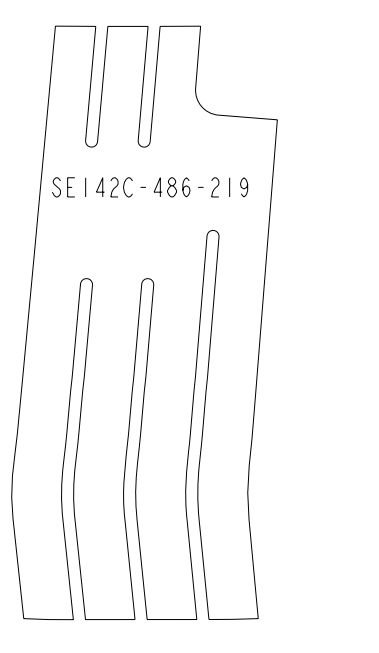

INSTANCE:  
SEI42C-486\_FLAT\_219

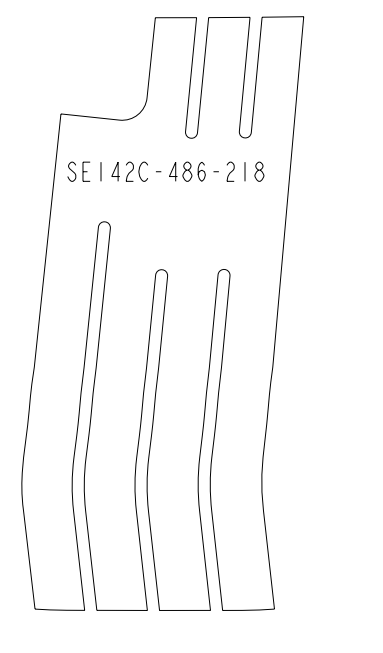

INSTANCE:  
SEI42C-486\_FLAT\_218

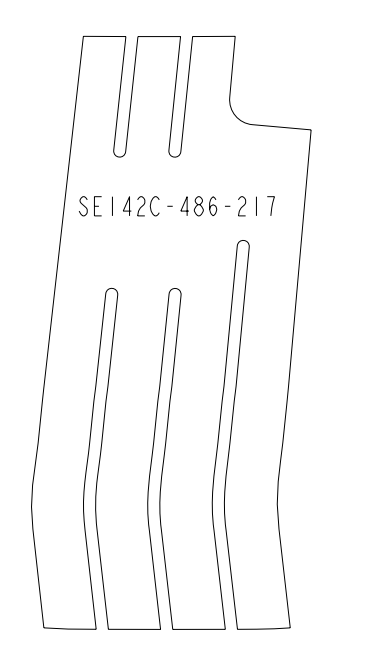

INSTANCE:  
SEI42C-486\_FLAT\_217

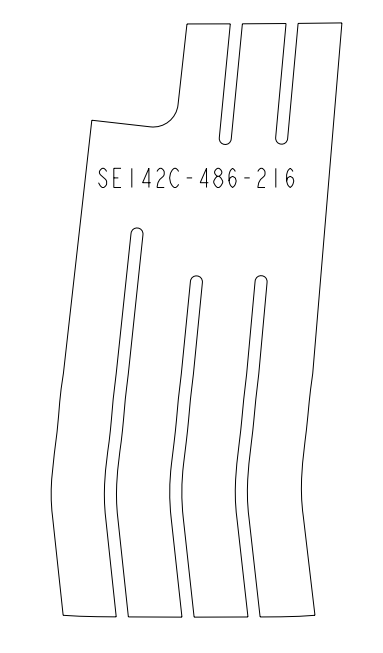

INSTANCE:  
SEI42C-486\_FLAT\_216

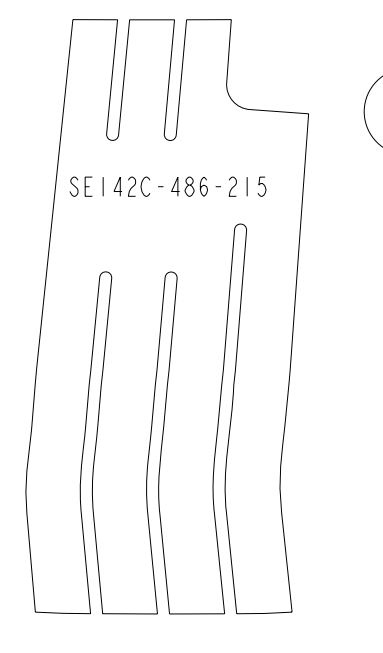

INSTANCE:  
SEI42C-486\_FLAT\_215

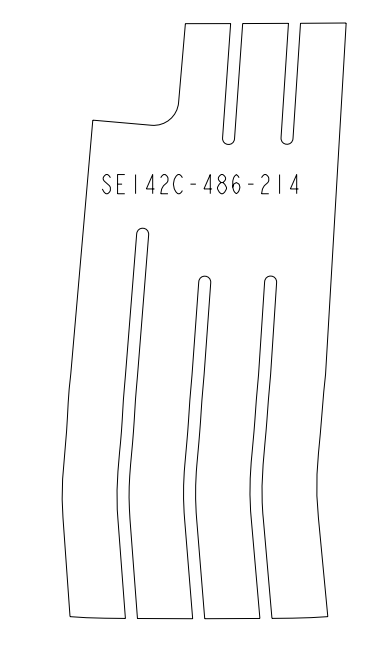

INSTANCE:  
SEI42C-486\_FLAT\_214

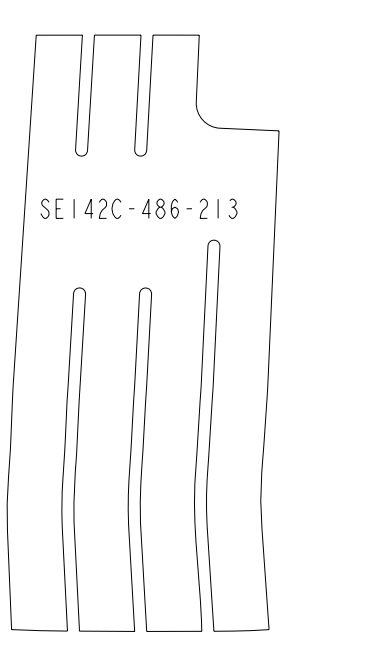

INSTANCE:  
SEI42C-486\_FLAT\_213

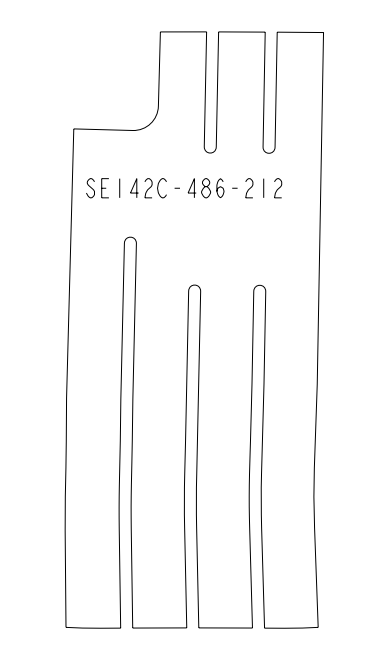

INSTANCE:  
SEI42C-486\_FLAT\_212

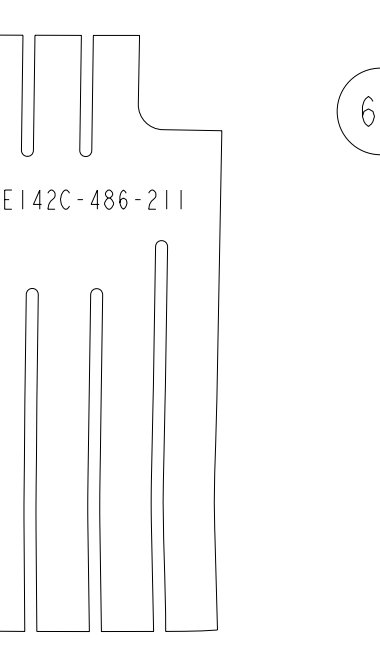

INSTANCE:  
SEI42C-486\_FLAT\_211

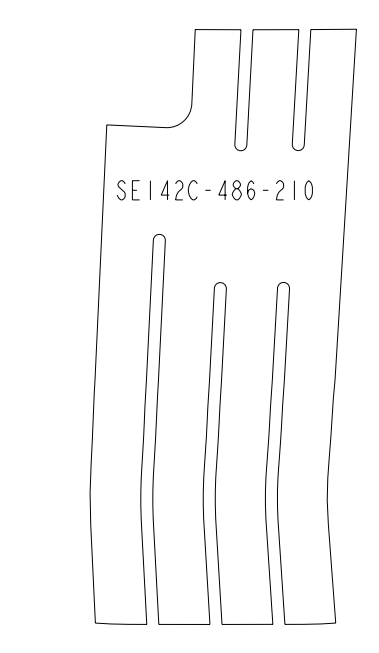

INSTANCE:  
SEI42C-486\_FLAT\_210

SCALE ALL VIEWS: 1.00

Oak Ridge National Laboratory managed for the DEPARTMENT OF ENERGY under U.S. GOVERNMENT CONTRACT DE-AC05-00OR22725 UT-BATTELLE, LLC., Oak Ridge, Tennessee PROJECT NAME									
<b>UT-BATTELLE</b> <b>NATIONAL COMPACT STELLARATOR EXPERIMENT</b> <b>MODULAR COIL TYPE - C</b> <b>SIDE -B UPPER (TOP) CHILL PLATES</b> <b>FLAT PATTERN LAYOUT</b>									
VERSION NO.	PLANT	BLDG	FL	SHT	OF	TYPE	CLASS		
3+	X-10	5700	3	4	5	S	U		
RELEASE LEVEL		SEI42C-486							
WIP									



⚠

THESE PARTS TO BE NEMA GRADE GIICR MATERIAL

SCALE ALL VIEWS: 1.00

UT-BATTELLE		Oak Ridge National Laboratory managed for the DEPARTMENT OF ENERGY under U.S. GOVERNMENT CONTRACT DE-AC05-00OR22725 UT-BATTELLE, LLC. Oak Ridge, Tennessee	
PROJECT NAME			
<b>NATIONAL COMPACT STELLARATOR EXPERIMENT</b>			
<b>MODULAR COIL TYPE - C</b>			
<b>SIDE -B UPPER (TOP) CHILL PLATES</b>			
<b>FLAT PATTERN LAYOUT</b>			
VERSION NO.	PLANT	BLDG	FL SHT OF TYPE CLASS
3+	X-10	5700	3 5 5 S U
RELEASE LEVEL		SE142C-486	
WIP		REV I	