

NO.	REVISION	BY	CH	SUP	APPROVED	DATE

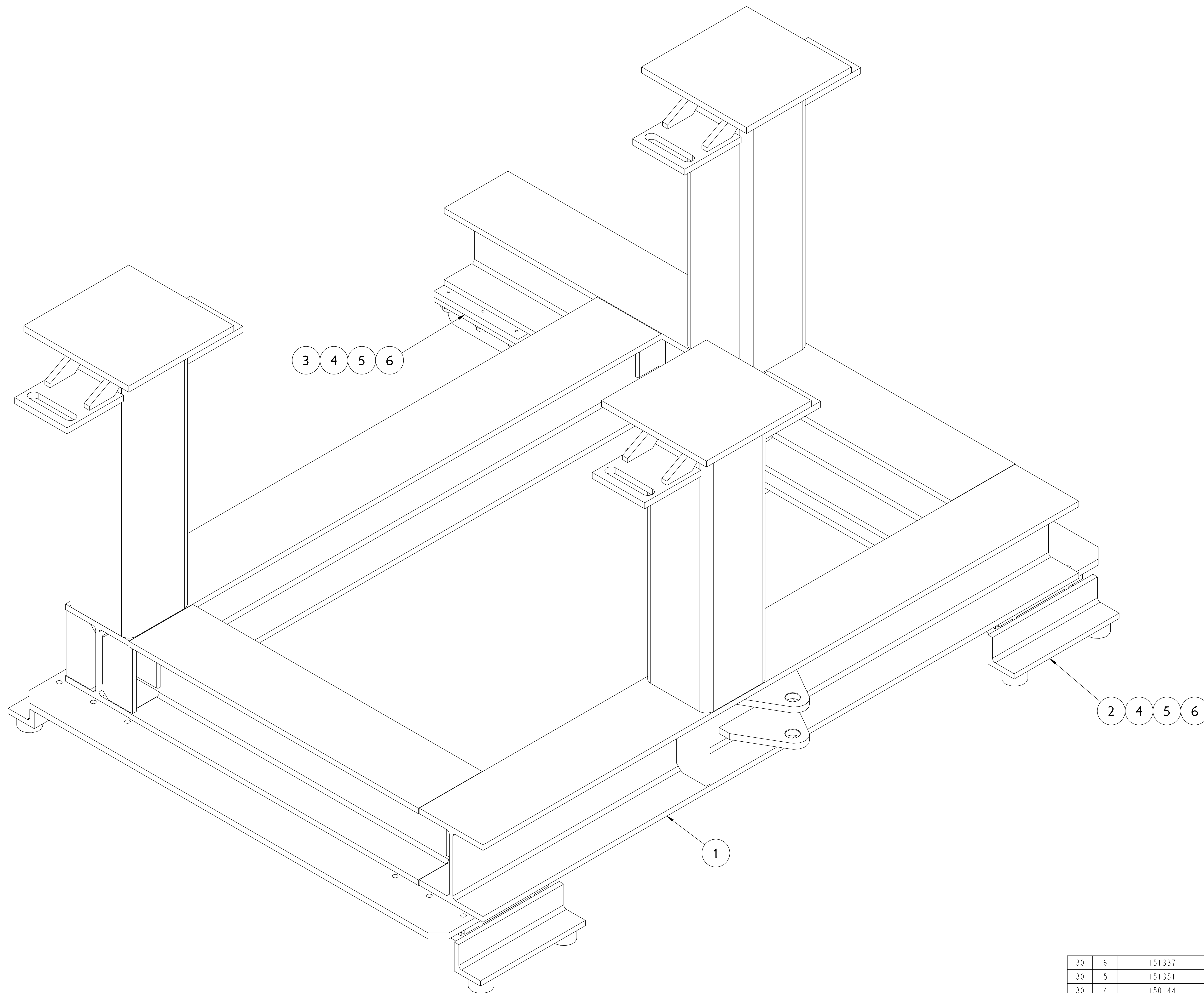

30	6	151337	1/2 SPLIT LOCK WASHER	C" STL - ZN PLT	
30	5	151351	1/2 FLAT WASHER	C" STL - ZN PLT	
30	4	150144	1/2-13UNC-2A x 1" LG HEX HEAD CAP SCREW	C" STL - ZN PLT	
1	3	COMM	HILMAN ROLLER - PRODUCT NO. 8-OT	STEEL	
4	2	COMM	HILMAN ROLLER - PRODUCT NO. 8-OT W/ ACCU-ROLL GUIDE MOUNT	STEEL	
1	1	SE186-330	MCWF RIGHT SIDE SUPPORT CART WELDMENT	SEE DWG	
1	1	THIS DWG	MCWF RIGHT SIDE SUPPORT CART ASSEMBLY	SEE DWG	
01	PART	DRAWING NO.	NOMENCLATURE	MATERIAL	QTY
ASSY	NO.		OR DESCRIPTION		REQD

PARTS LIST

COMPUTER GENERATED DRAWING MANUAL CHANGES NOT PERMITTED Pro E DO NOT VERIFY INFORMATION BY SCALING DRAWING	CENTRAL FILES:	PRINCETON PLASMA PHYSICS LABORATORY			
	UNLESS OTHERWISE SPECIFIED	NATIONAL COMPACT STELLARATOR EXPERIMENT			
	DIMENSIONS ARE IN INCHES MACHINE SURFACES	STELLARATOR CORE TOOLING DESIGN & FABRICATION			
	BREAK SHARP EDGES .005/.020	MCWF RIGHT SIDE SUPPORT CART ASSEMBLY			
	TOLERANCES NON-CUMULATIVE	DSN: J. RUSHINSKI	8-2-2007	DRAWING NO:	
	DECIMAL-INCH FRACTIONS	CHK: M. COLE	8-2-2007	SE186-315	
	NEXT ASSEMBLY	ENGR: T. BROWN	8-2-2007		
	.XX +/- .030	SUPV: J. SIEGEL	8-2-2007	SHEET 1 OF 1	REV 0
	.XXX +/- .005				
	ANGULAR +/- .015				

RELEASE LEVEL: WIP
DWG VERSION NO: 26

NCSX-SE186-315