

ISOMETRIC VIEW
SCALE 0.500

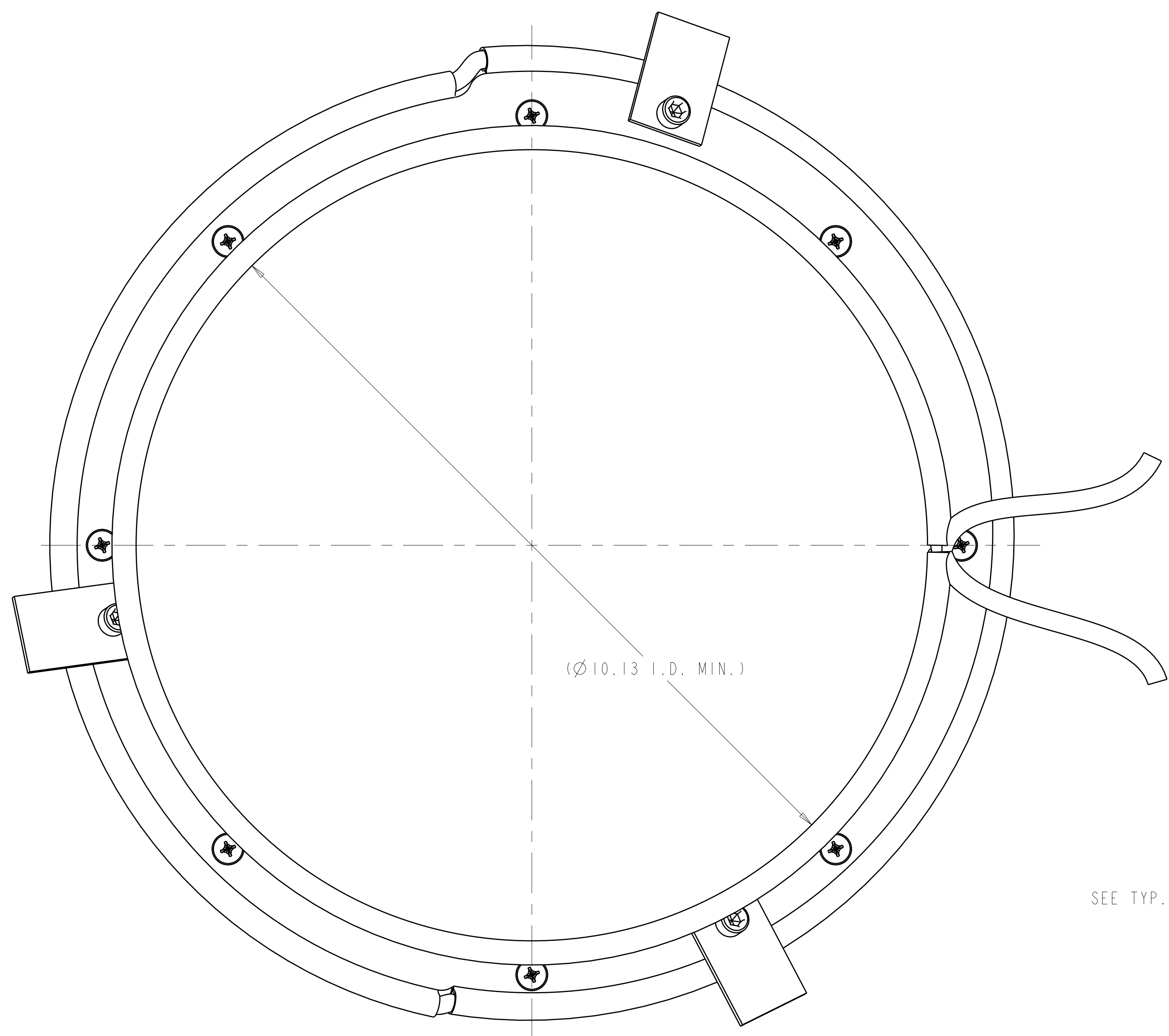

1 PORT 7 WINDING FORM SEAL ASSEMBLY
SCALE 1.000

LABEL PART NUMBER AND REVISION
WITH PERMANENT INK

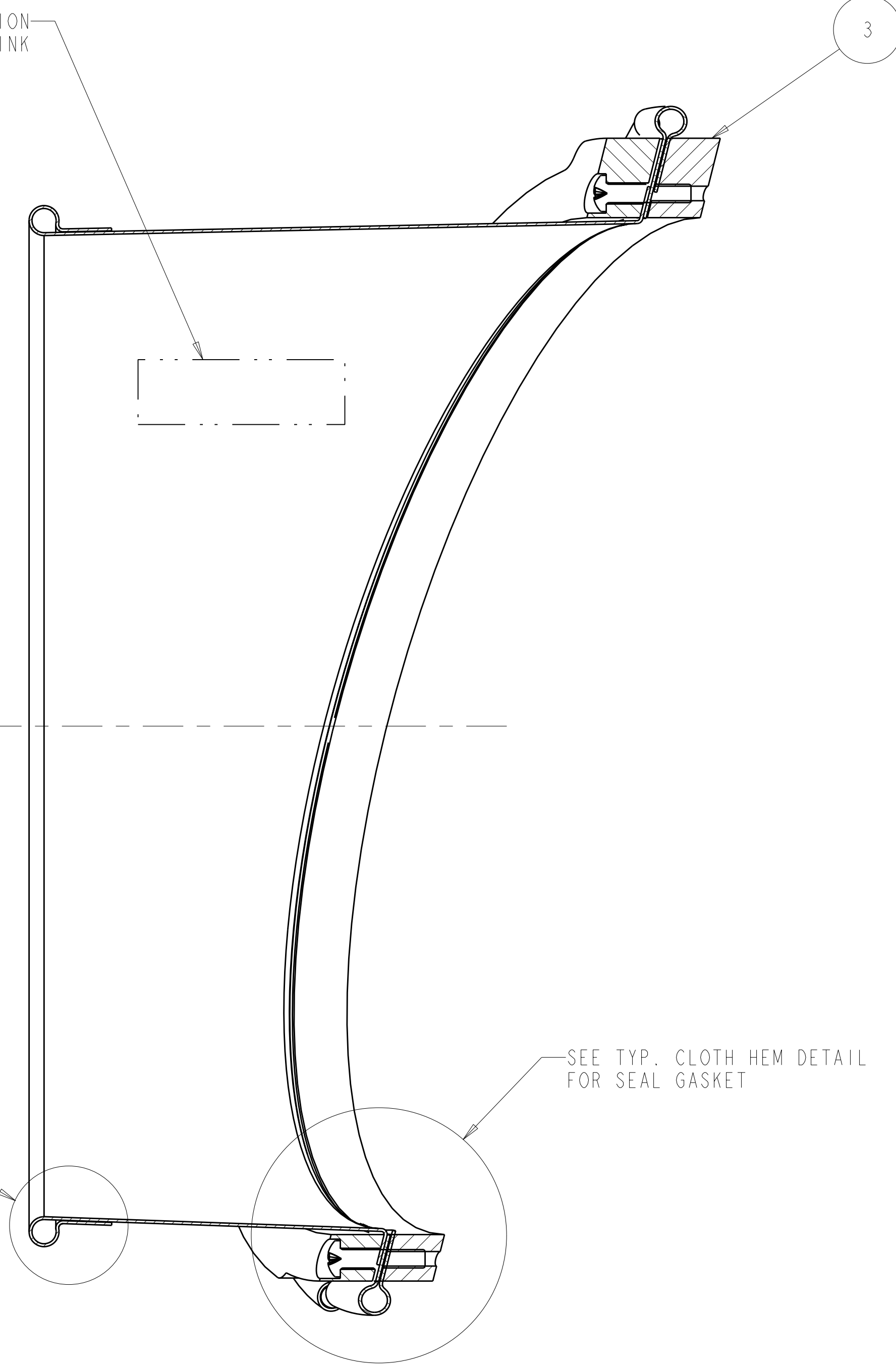

SECTION A-A

- NOTES
1. DRAWING PREPARED IN ACCORDANCE WITH ASME Y14.100-2004.
 2. INTERPRET DIMENSIONS AND TOLERANCES PER ASME Y14.5M-1994.
 3. DIMENSIONS ARE IN INCHES.

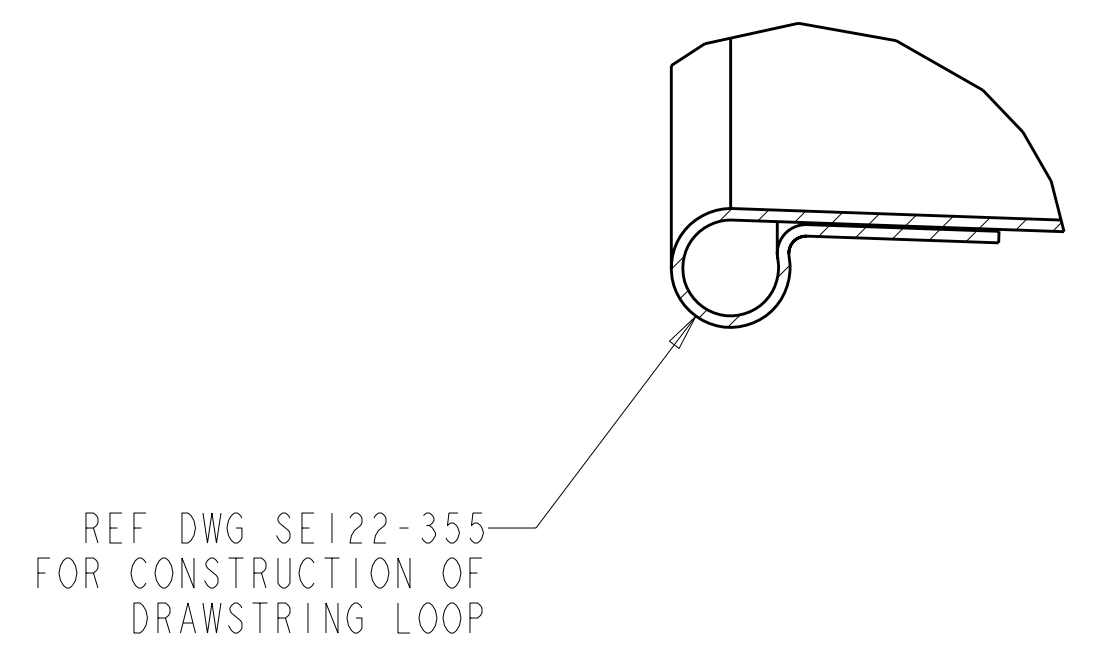

TYPICAL CLOTH HEM DETAIL
FOR DRAWSTRING
SCALE 2.00

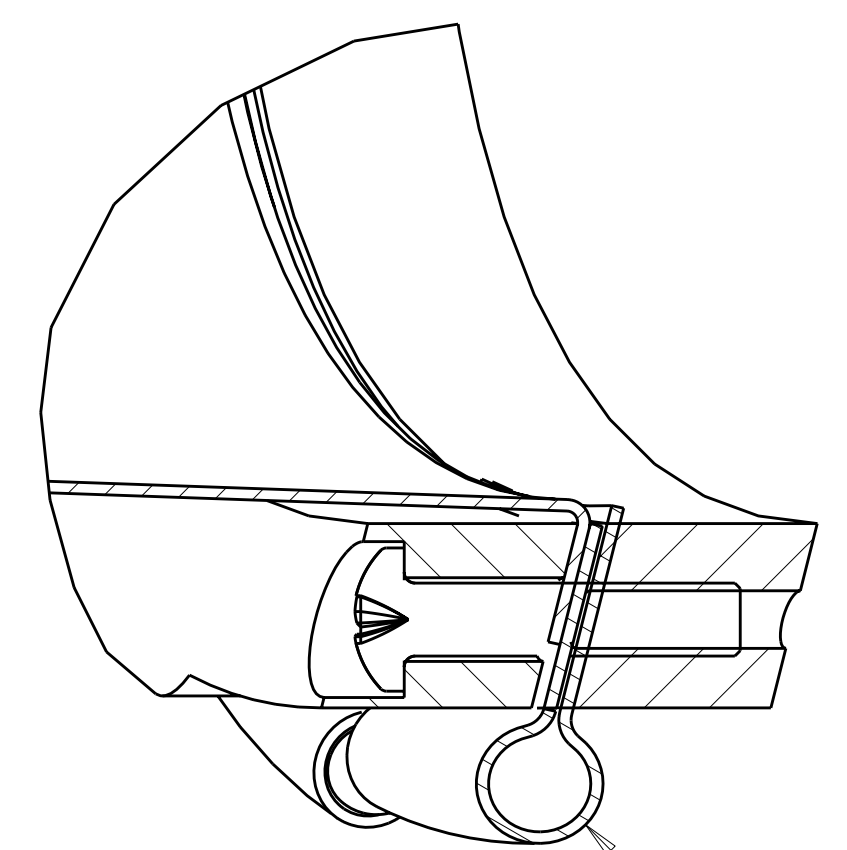

TYPICAL CLOTH HEM DETAIL
FOR SEAL GASKET
SCALE 2.00

CAGE CODE	PART OR IDENTIFYING NO	NOMENCLATURE OR DESCRIPTION	MATERIAL	SPECIFICATION	FIND NO
8	94070A247	#10-24 UNC X 1.00 LG PAN HEAD PHILLIPS MACHINE SCREW	BRASS	MCMaster CARR P.O. BOX 740100 ATLANTA, GA 30374-0100 (404) 346-7000 WWW.MCMaster.COM	7
3	93465A537	1/4-20 UNC X .50 LG SHCS			6
3	SE122-399-1	PORT CLIP			5
1	SE122-355-1	PORT 7 WINDING FORM SEAL BOOT ASSEMBLY			4
1	SE122-354-1	PORT 7 WINDING FORM SEAL INNER PLATE			3
1	SE122-353-1	PORT 7 WINDING FORM SEAL OUTER PLATE			2
AR	X	-1			1
SE122-004-1					

← NEXT ASSEMBLY

NO REPRESENTATION OR WARRANTY, EXPRESSED OR IMPLIED, IS MADE AS TO THE ACCURACY, COMPLETENESS OR USEFULNESS OF THE INFORMATION OR STATEMENTS CONTAINED IN THESE DRAWINGS, OR THAT THE USE OR DISCLOSURE OF ANY INFORMATION, APPARATUS, METHOD OR PROCESS DISCLOSED IN THESE DRAWINGS MAY NOT INFRINGE PRIVATE RIGHTS OF OTHERS. NO LIABILITY IS ASSUMED WITH RESPECT TO THE USE OF, OR FOR DAMAGES RESULTING FROM THE USE OF, ANY INFORMATION, APPARATUS, METHOD OR PROCESS DISCLOSED IN THESE DRAWINGS. DRAWINGS MADE AVAILABLE FOR PURPOSES, AND ARE TO BE RETURNED UPON REQUEST OF THE FORWARDING CONTRACTOR.

P THIS DRAWING PRODUCED ON PRO-ENGINEER

REV	DESCRIPTION	BY	DATE	CHK	DEPT	DATE	PE	REQ	DATE	ORNL	DOE	DATE
0	ORIGINAL ISSUE	RAH	01/07	SP		01/07						
	REVISION OR ISSUE PURPOSE											

SCALE NOTED	DES P. L. GORANSON 01/07
TOLERANCES UNLESS OTHERWISE SPECIFIED	DRW R. A. HURD 01/07
FRACTIONS	CHK S. PARSON 01/07
XX DECIMALS ±.01	DEPT :
XXX DECIMALS ±.005	FE :
ANGLES ±0°15'	CR :
BREAK SHARP EDGES OR MAX FINISH .125 UNLESS OTHERWISE SPECIFIED	PJ :
	RD :
	REO :
	PPPL DRFT J. SIEGEL 01/07
	VERSION NO. 4+
	PLANT ORNL
	BLDG 5700
	FL 3
	SHT 1
	OF 1
	TYPE A
	CLASS U
	REV 0

Oak Ridge National Laboratory managed for the DEPARTMENT OF ENERGY under U.S. GOVERNMENT contract DE-AC05-00OR22725 UT-BATTELLE, LLC. Oak Ridge, Tennessee

UT-BATTELLE

NATIONAL COMPACT STELLARATOR EXPERIMENT

PORT 7 WINDING FORM SEAL ASSEMBLY

SE122-352