

ISOMETRIC VIEW
SCALE 1.000

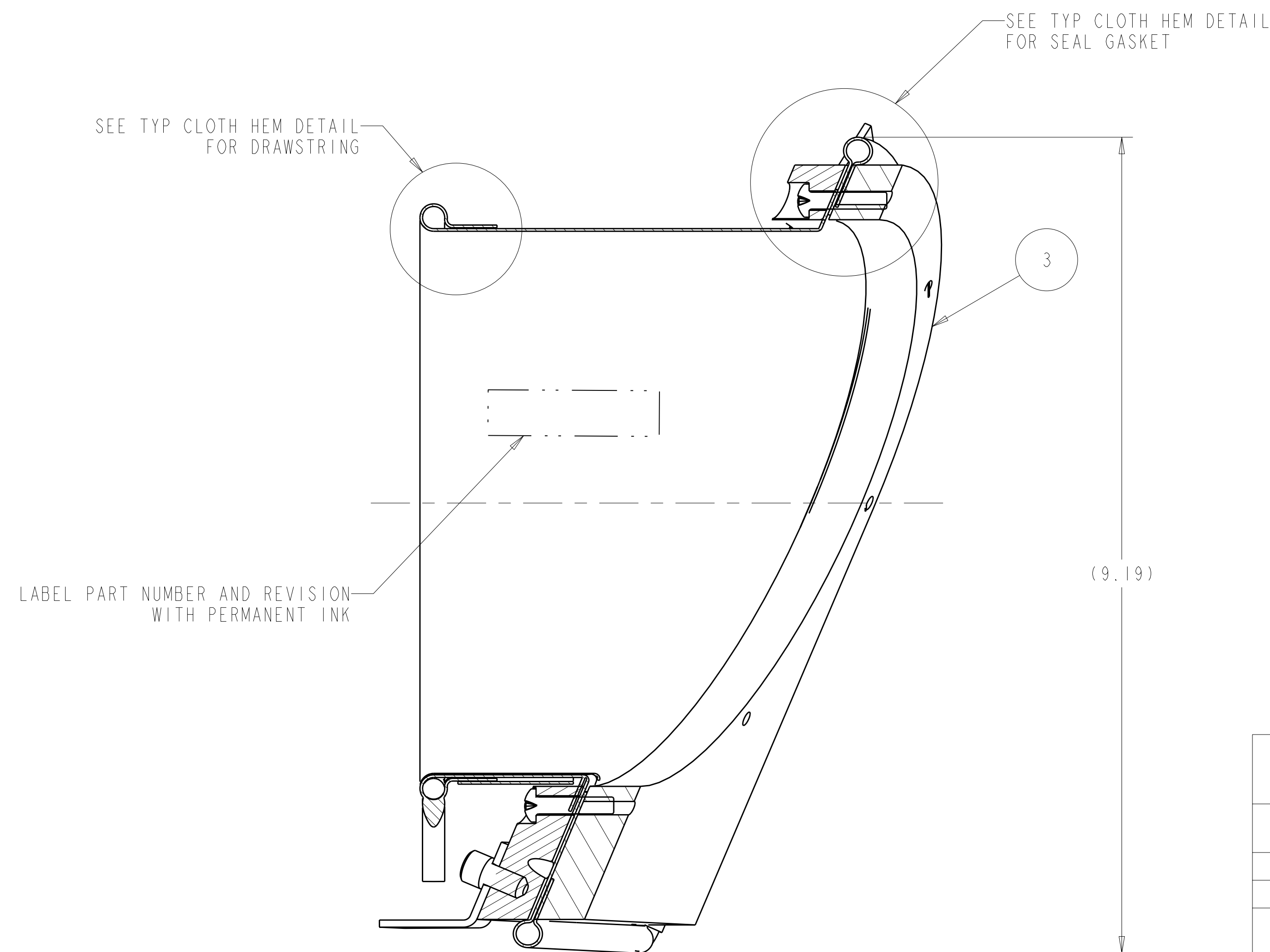
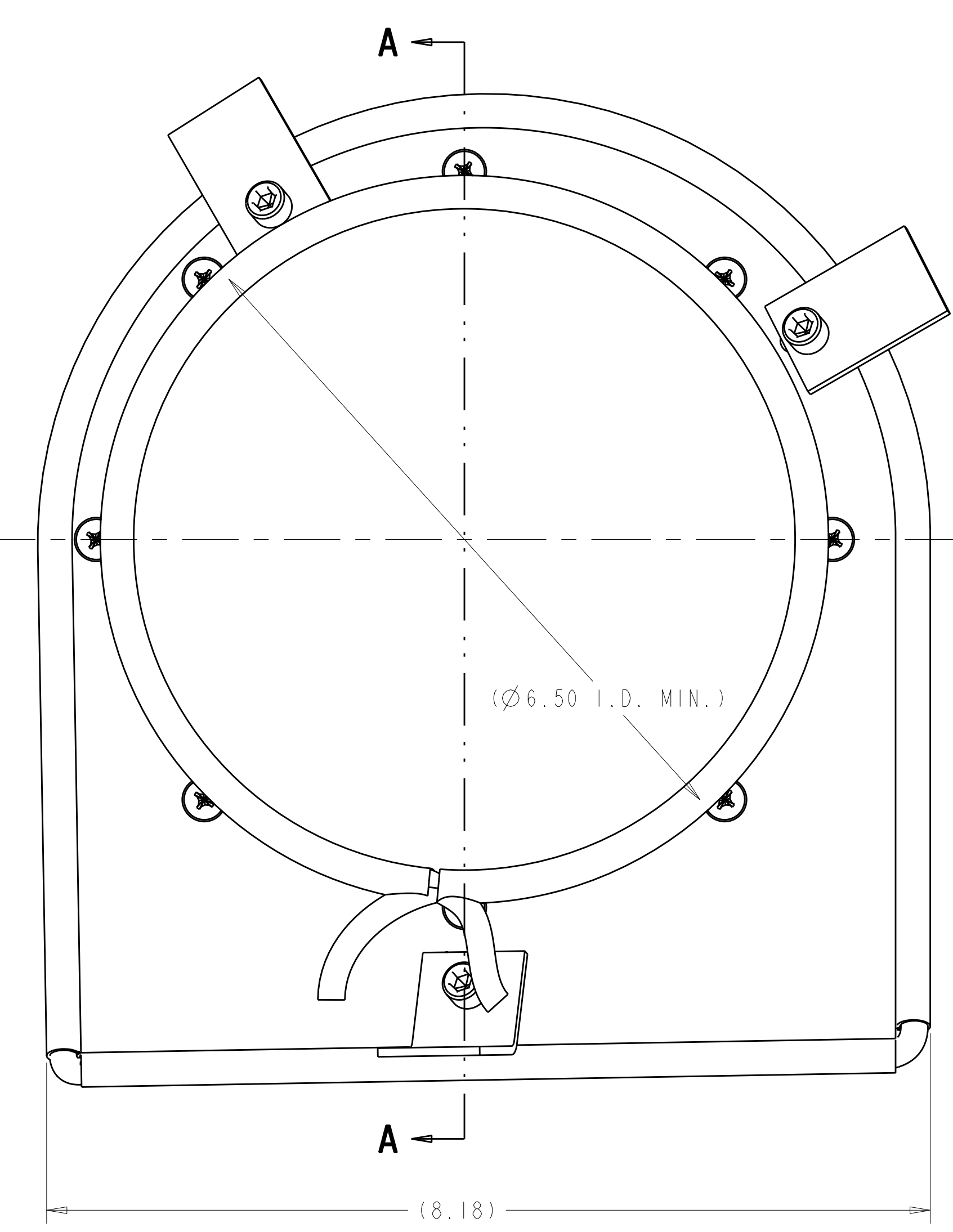

SECTION A-A

-1 PORT 17 WINDING FORM SEAL ASSEMBLY
SCALE 1.000

NOTES
1. DRAWING PREPARED IN ACCORDANCE WITH ASME Y14.100-2004.
2. INTERPRET DIMENSIONS AND TOLERANCES PER ASME Y14.5M-1994.
3. DIMENSIONS ARE IN INCHES.

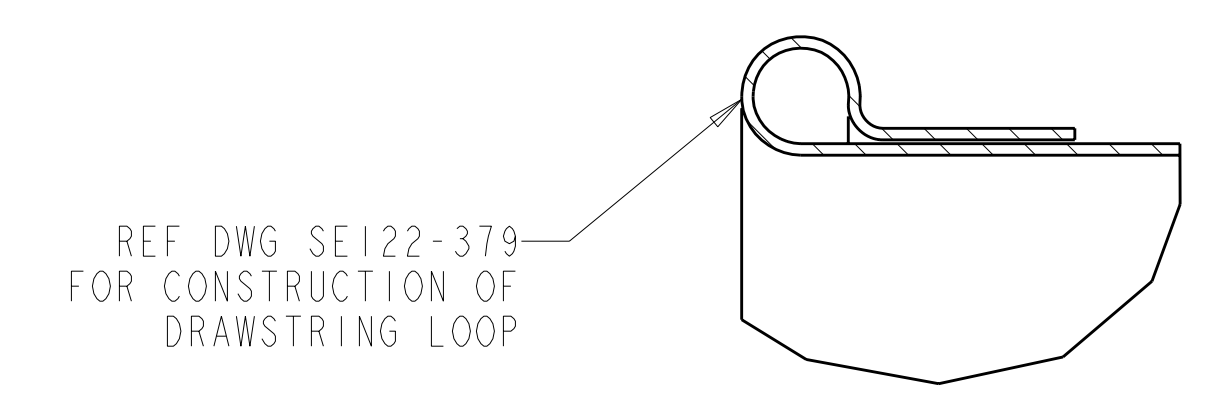

TYPICAL CLOTH HEM DETAIL FOR DRAWSTRING
SCALE 2.00

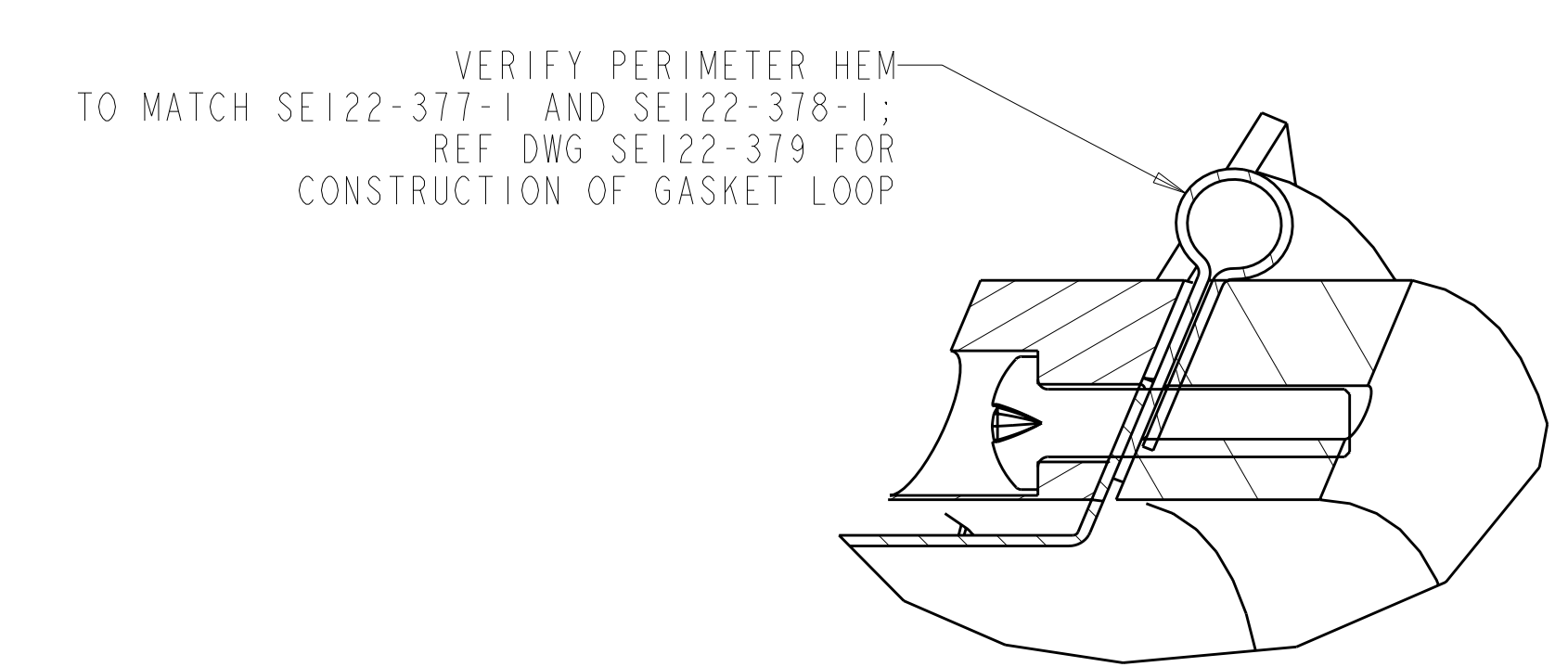

TYPICAL CLOTH HEM DETAIL FOR SEAL GASKET
SCALE 2.00

CAGE CODE	PART OR IDENTIFYING NO	NOMENCLATURE OR DESCRIPTION	MATERIAL	SPECIFICATION	FIND NO
8	94070A247	#10-24 UNC X 1.00 LG PAN HEAD PHILLIPS MACHINE SCREW	BRASS	MCMASTER CARR P.O. BOX 740100 ATLANTA, GA 30374-0100 (404) 346-7000 WWW.MCMASTER.COM	8
3	93465A537	1/4-20 UNC X .50 LG SHCS			7
1	SE122-399-2	PORT CLIP			6
2	SE122-399-1	PORT CLIP			5
1	SE122-379-1	PORT 17 WINDING FORM SEAL BOOT ASSEMBLY			4
1	SE122-378-1	PORT 17 WINDING FORM SEAL INNER PLATE			3
1	SE122-377-1	PORT 17 WINDING FORM SEAL OUTER PLATE			2
AR	-1	PORT 17 WINDING FORM SEAL ASSEMBLY			1

← NEXT ASSEMBLY

NO REPRESENTATION OR WARRANTY, EXPRESSED OR IMPLIED, IS MADE AS TO THE ACCURACY, COMPLETENESS OR USEFULNESS OF THE INFORMATION OR STATEMENTS CONTAINED IN THESE DRAWINGS, OR THAT THE USE OR DISCLOSURE OF ANY INFORMATION, APPARATUS, METHOD OR PROCESS DISCLOSED IN THESE DRAWINGS MAY NOT INFRINGE PRIVATE RIGHTS OF OTHERS. NO LIABILITY IS ASSUMED WITH RESPECT TO THE USE OF, OR FOR DAMAGES RESULTING FROM THE USE OF, ANY INFORMATION, APPARATUS, METHOD OR PROCESS DISCLOSED IN THESE DRAWINGS. DRAWINGS MADE AVAILABLE FOR INFORMATION TO BIDDER ARE NOT TO BE USED FOR OTHER PURPOSES, AND ARE TO BE RETURNED UPON REQUEST OF THE FORWARDING CONTRACTOR.

P THIS DRAWING PRODUCED ON PRO-ENGINEER

REV	DESCRIPTION	BY	DATE	CHK	DEPT	DATE	PE	REQ	DATE	ORNL	DOE	DATE
0	ORIGINAL ISSUE	RAH	01/07	SP		01/07						

SCALE	NOTED	DES	DATE
		P. L. GORANSON	01/07
		R. A. HURD	01/07
		S. PARSON	01/07
		J. SIEGEL	01/07

VERSION NO.	PLANT	BLDG	FL	SHT	OF	TYPE	CLASS
4+	ORNL	5700	3	1	1	A	U

RELEASE LEVEL: WIP

SE122-376

SE122-376