

- NOTES
1. DRAWING PREPARED IN ACCORDANCE WITH ASME Y14.100-2004.
 2. INTERPRET DIMENSIONS AND TOLERANCES PER ASME Y14.5M-1994.
 3. DIMENSIONS ARE IN INCHES.

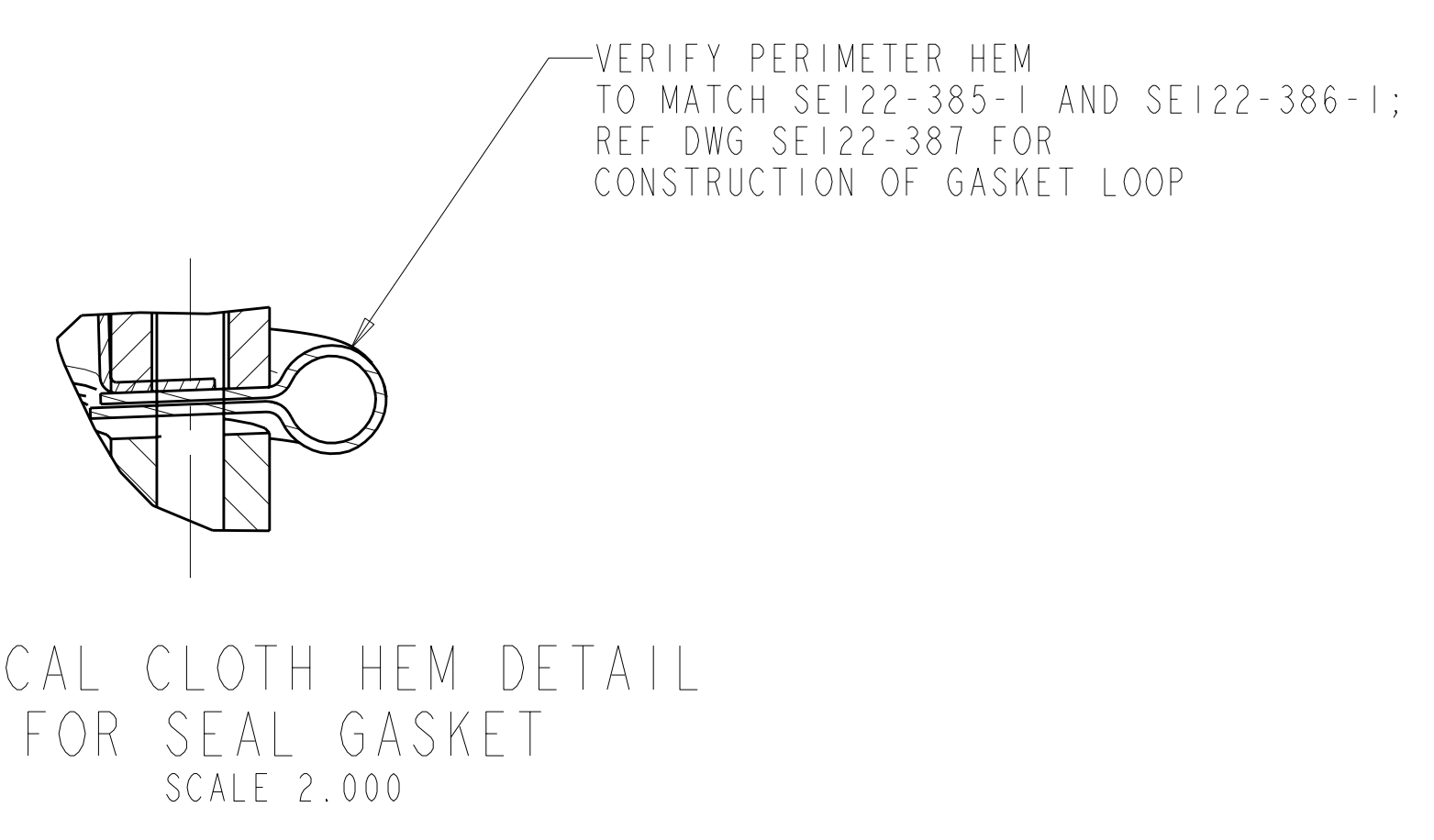
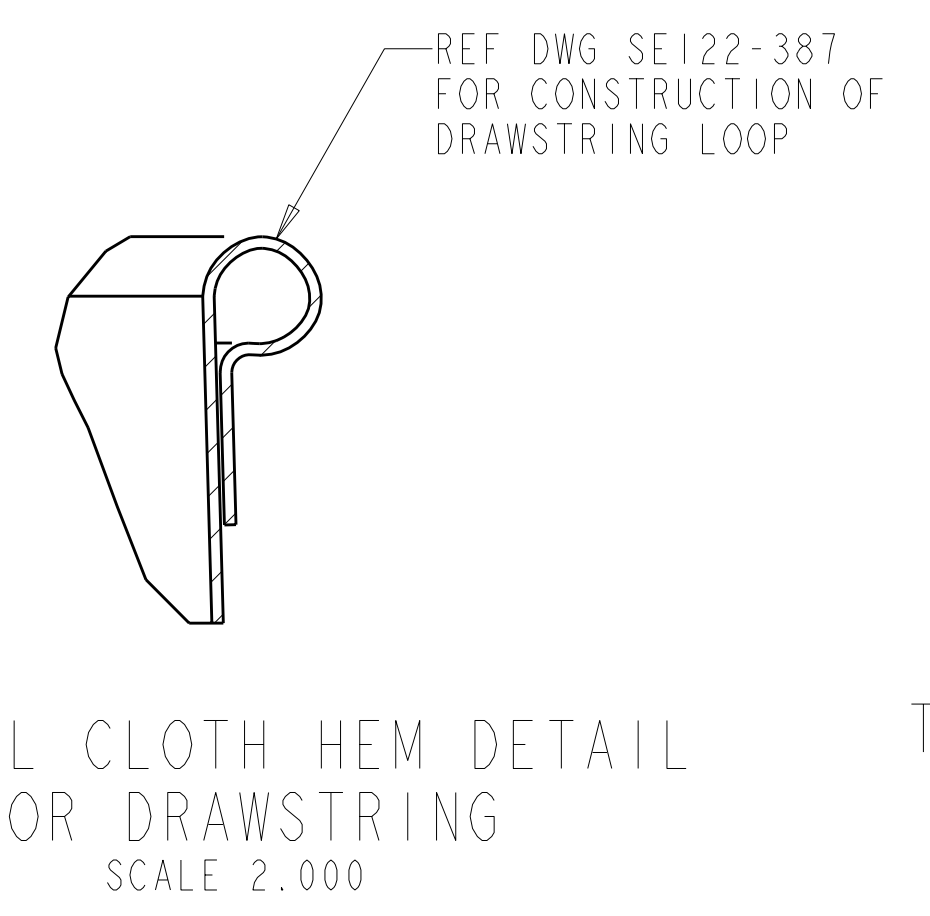
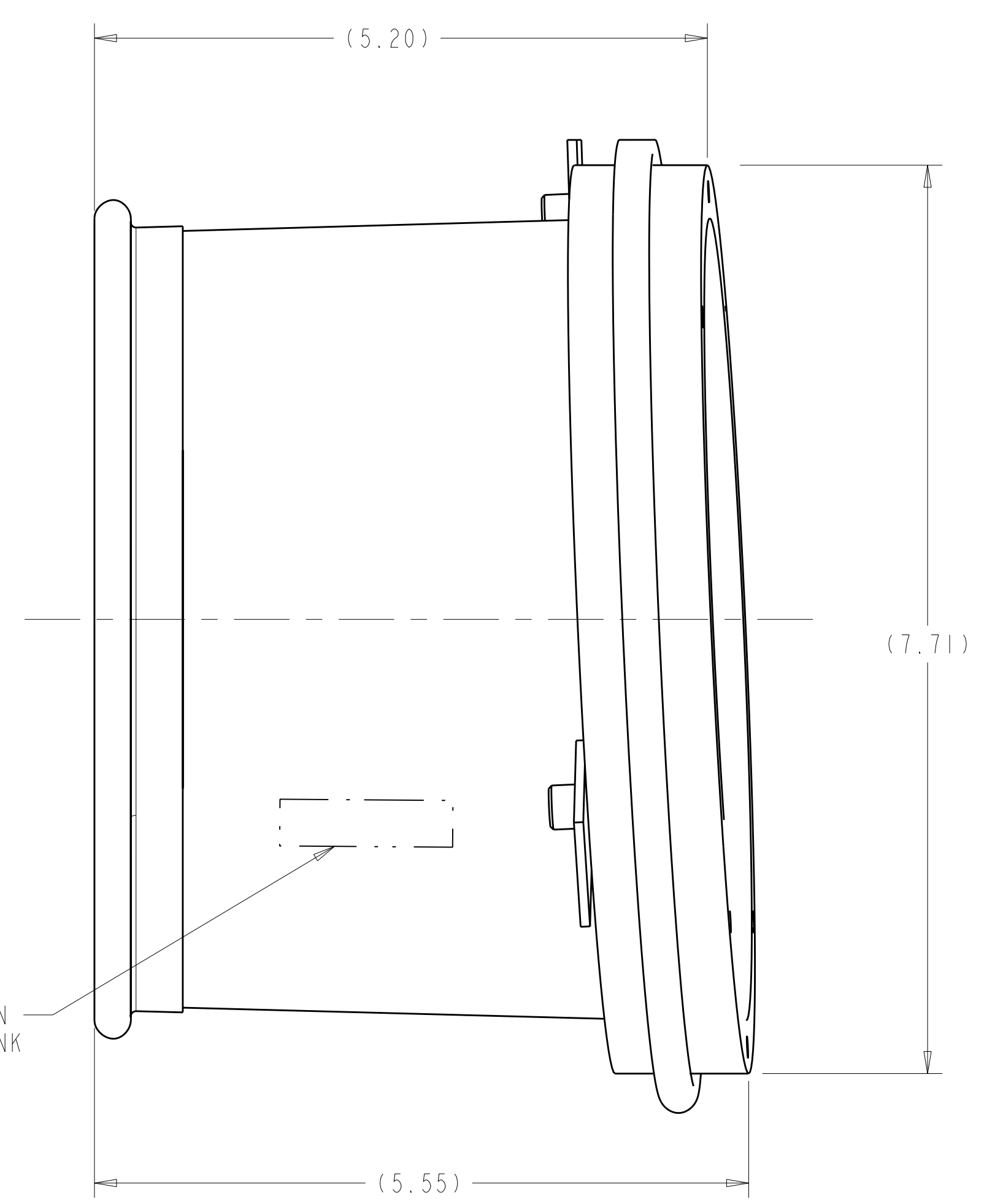
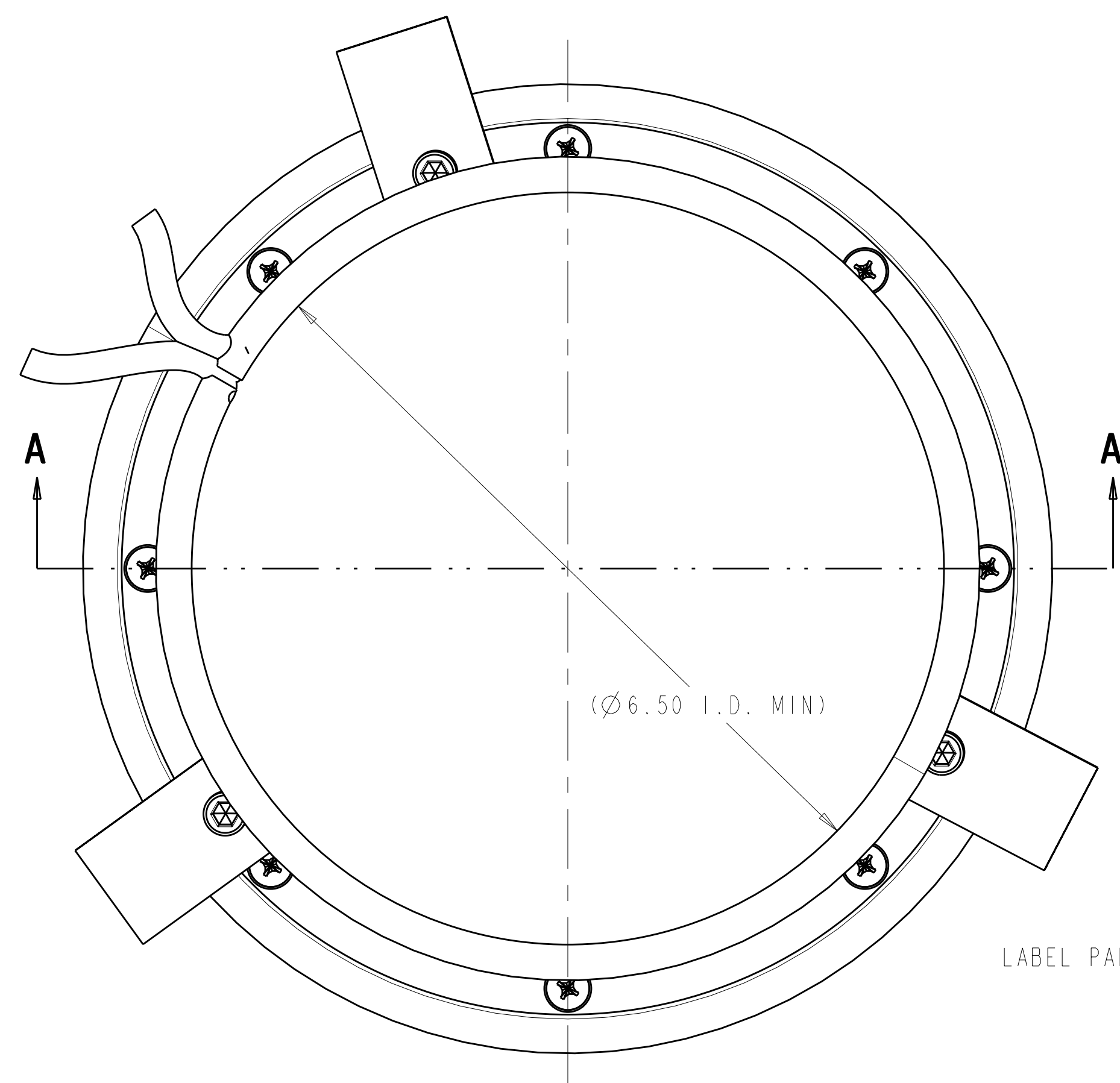
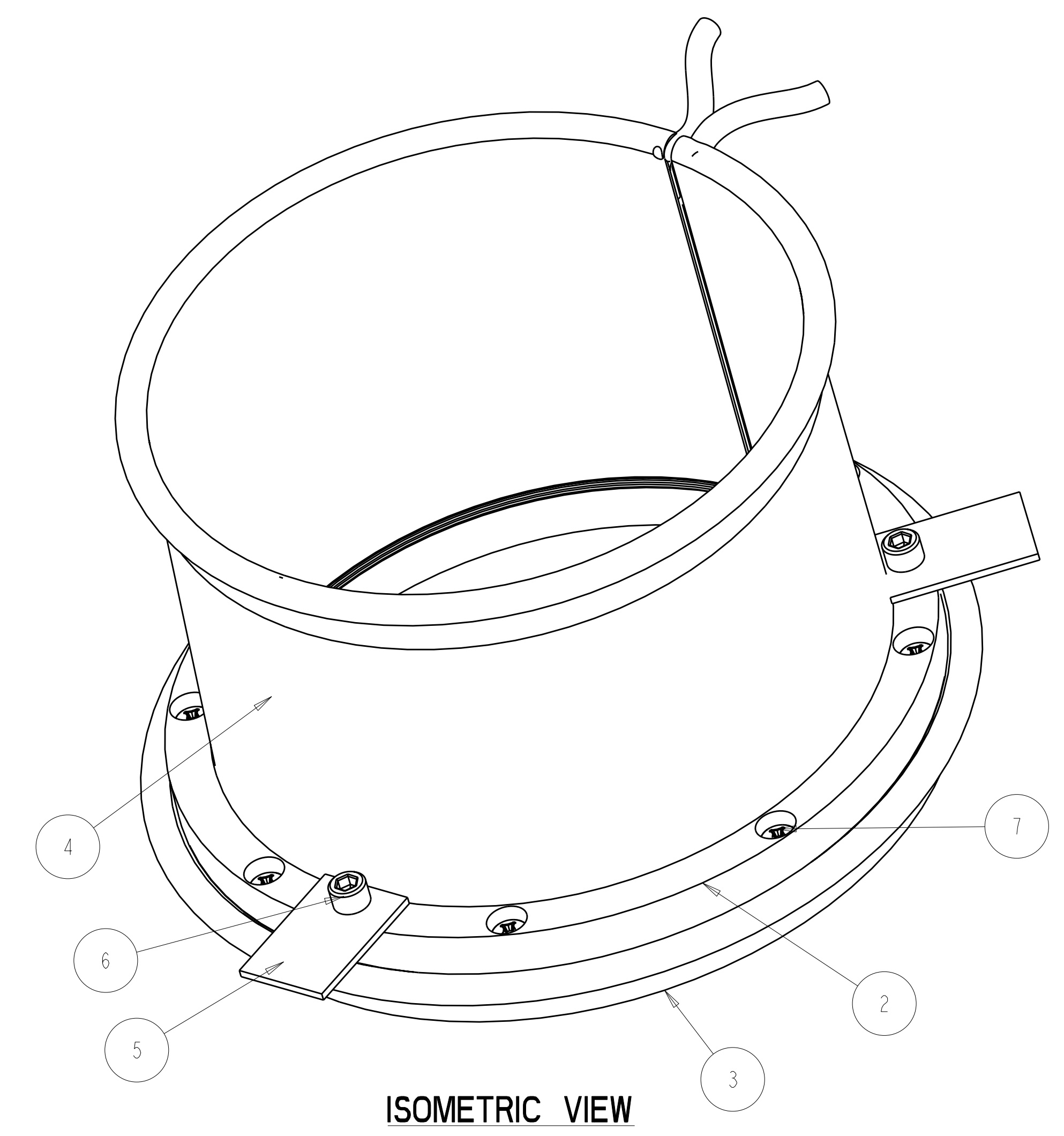
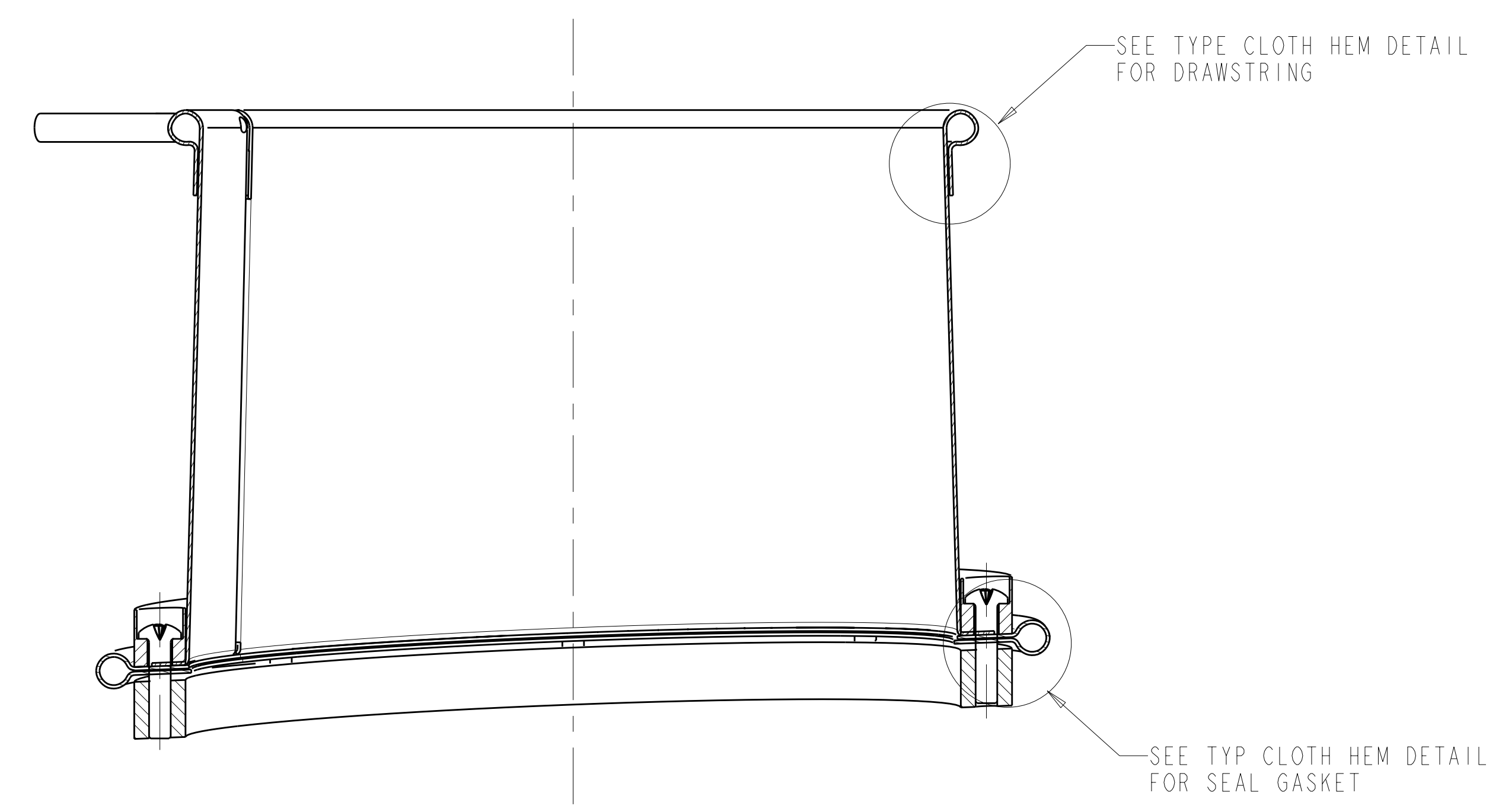
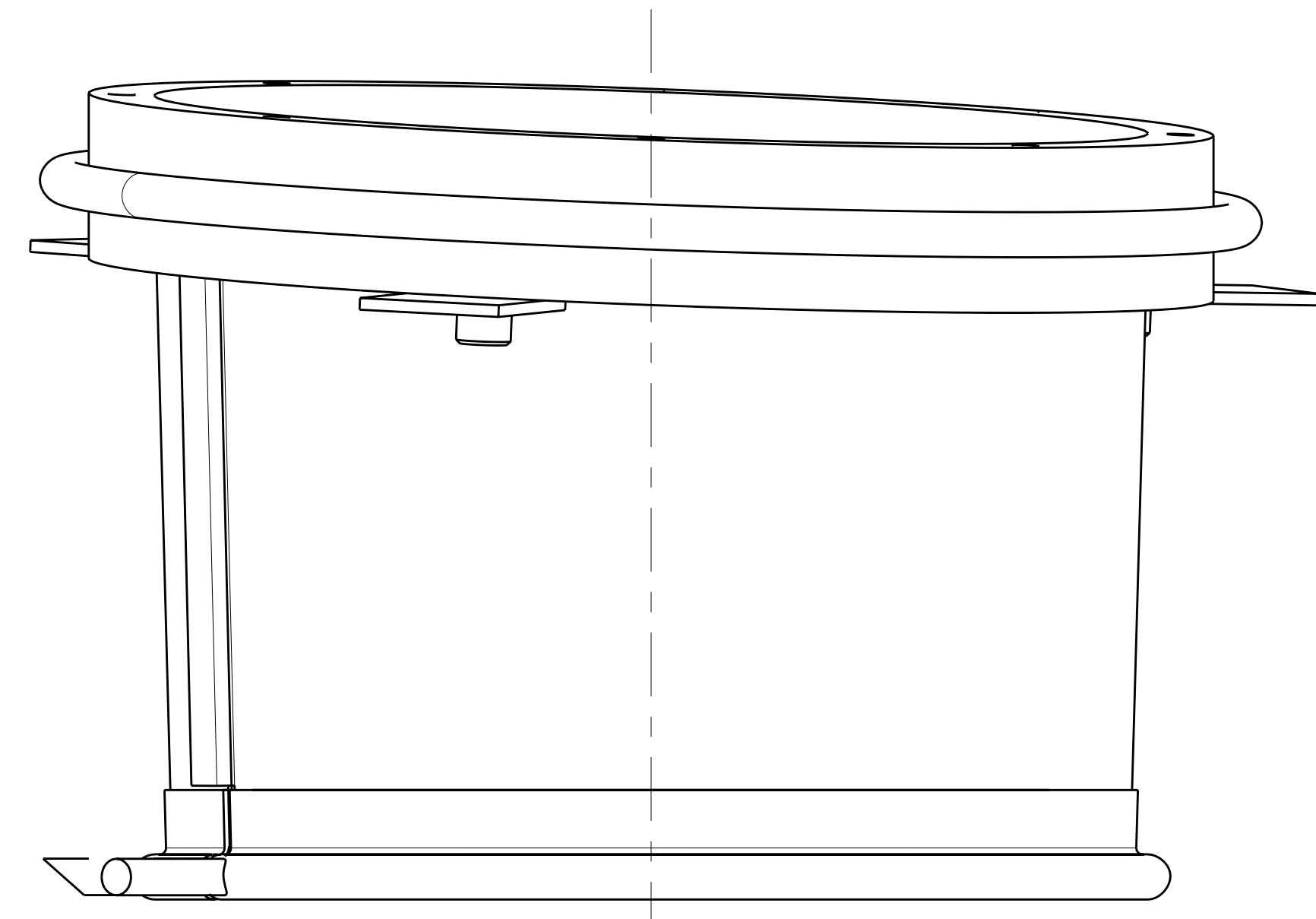

LABEL PART NUMBER AND REVISION USING PERMANENT INK

-1 PORT 8 WINDING FORM SEAL ASSEMBLY
SCALE 1.000

REV	DESCRIPTION	BY	DATE	CHK	DEPT	DATE	PE	REQ	DATE	ORNL	DOE	DATE
0	ORIGINAL ISSUE	MTR	01/07	SP		01/07						

CAGE CODE	PART OR IDENTIFYING NO	NOMENCLATURE OR DESCRIPTION	MATERIAL	SPECIFICATION	FIND NO
8	94070A247	#10-24 UNC X 1.00 LG PAN HEAD PHILLIPS MACHINE SCREW	BRASS	MCMASTER CARR P.O. BOX 740100 ATLANTA, GA 30374-0100 (404) 346-7000 WWW.MCMASTER.COM	7
3	93465A537	1/4-20 UNC X .50 LG SHCS			6
3	SE122-399-1	PORT CLIP			5
1	SE122-387-1	PORT 8 WINDING FORM SEAL BOOT ASSEMBLY			4
1	SE122-386-1	PORT 8 WINDING FORM SEAL INNER PLATE			3
1	SE122-385-1	PORT 8 WINDING FORM SEAL OUTER PLATE			2
AR	-1	PORT 8 WINDING FORM SEAL ASSEMBLY			1

SE122-004-1

NO REPRESENTATION OR WARRANTY, EXPRESSED OR IMPLIED, IS MADE AS TO THE ACCURACY, COMPLETENESS OR USEFULNESS OF THE INFORMATION OR STATEMENTS CONTAINED IN THESE DRAWINGS, OR THAT THE USE OR DISCLOSURE OF ANY INFORMATION, APPARATUS, METHOD OR PROCESS DISCLOSED IN THESE DRAWINGS MAY NOT INFRINGE PRIVATE RIGHTS OF OTHERS. NO LIABILITY IS ASSUMED WITH RESPECT TO THE USE OF, OR FOR DAMAGES RESULTING FROM THE USE OF, ANY INFORMATION, APPARATUS, METHOD OR PROCESS DISCLOSED IN THESE DRAWINGS. DRAWINGS MADE AVAILABLE FOR INFORMATION TO BIDDER ARE NOT TO BE USED FOR OTHER PURPOSES, AND ARE TO BE RETURNED UPON REQUEST OF THE FORWARDING CONTRACTOR.

P THIS DRAWING PRODUCED ON PRO-ENGINEER

SCALE NOTED

TOLERANCES UNLESS OTHERWISE SPECIFIED

FRACTIONS :
XX DECIMALS ±.01
XXX DECIMALS ±.005
ANGLES ±0°15'
BREAK SHARP EDGES OR MAX
FINISH :25 UNLESS OTHERWISE SPECIFIED

DES PL GORANSON 01/07
DRW MT BROWN 01/07
CHK S PARSON 01/07

DEPT :
SECT :
PE :
CR :
PJ :
RD :
PPPL DRFT J SIEGEL 01/07

UT-BATTELLE
Oak Ridge National Laboratory managed for the DEPARTMENT OF ENERGY under U.S. GOVERNMENT contract DE-AC05-00OR22725 UT-BATTELLE, LLC, Oak Ridge, Tennessee
PROJECT NAME
NATIONAL COMPACT STELLARATOR EXPERIMENT

PORT 8 WINDING FORM SEAL ASSEMBLY

VERSION NO. 7+
PLANT ORNL
BLDG 5700
FL 3
SHT 1
OF 1
TYPE I
CLASS A
U
REV 0

RELEASE LEVEL WIP
SE122-384