

- NOTES
1. DRAWING PREPARED IN ACCORDANCE WITH ASME Y14.100-2004.
  2. INTERPRET DIMENSIONS AND TOLERANCES PER ASME Y14.5M-1994.
  3. DIMENSIONS ARE IN INCHES
  - 4 PART TO BE MANUFACTURED FROM PRO/ENGINEER DATA FILE SE122-385.PRT. DIMENSIONS SHOWN ARE FOR PART VERIFICATION ONLY.

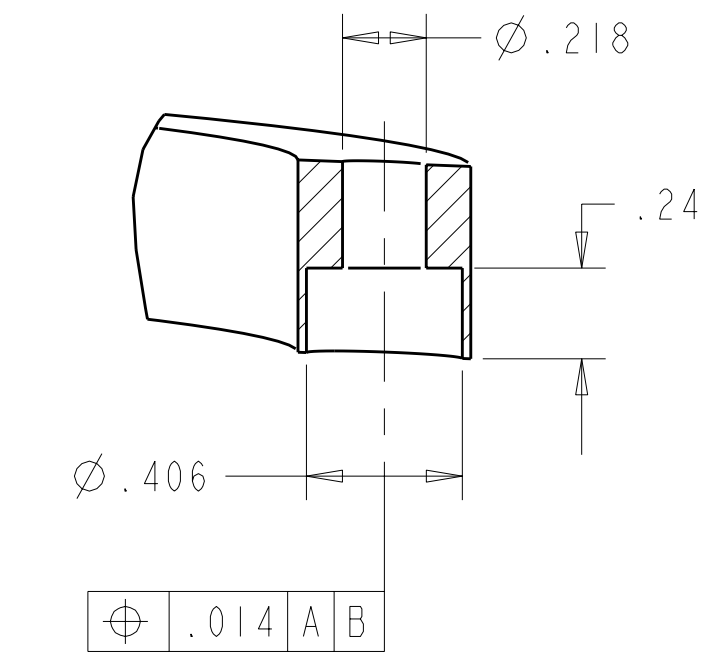

SECTION A-A  
TYP 8X  
SCALE 2.000

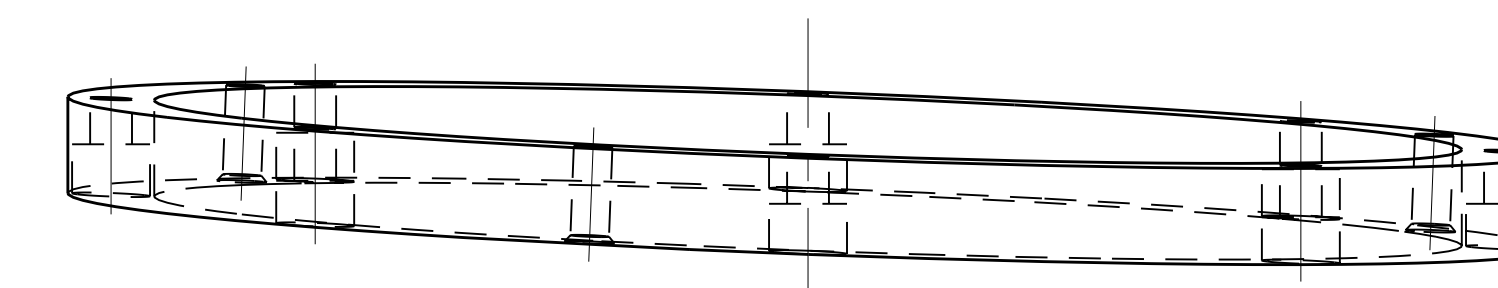
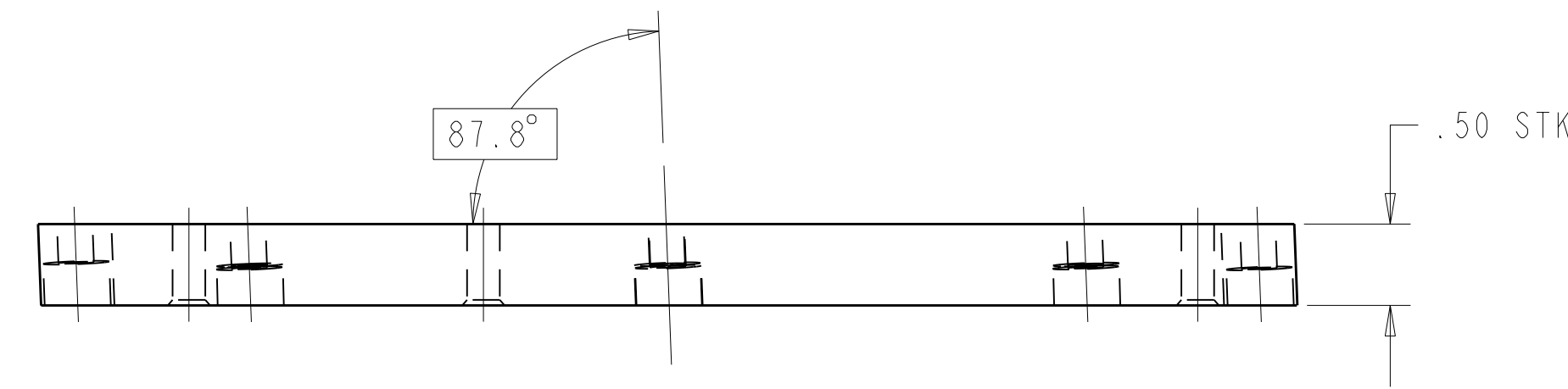
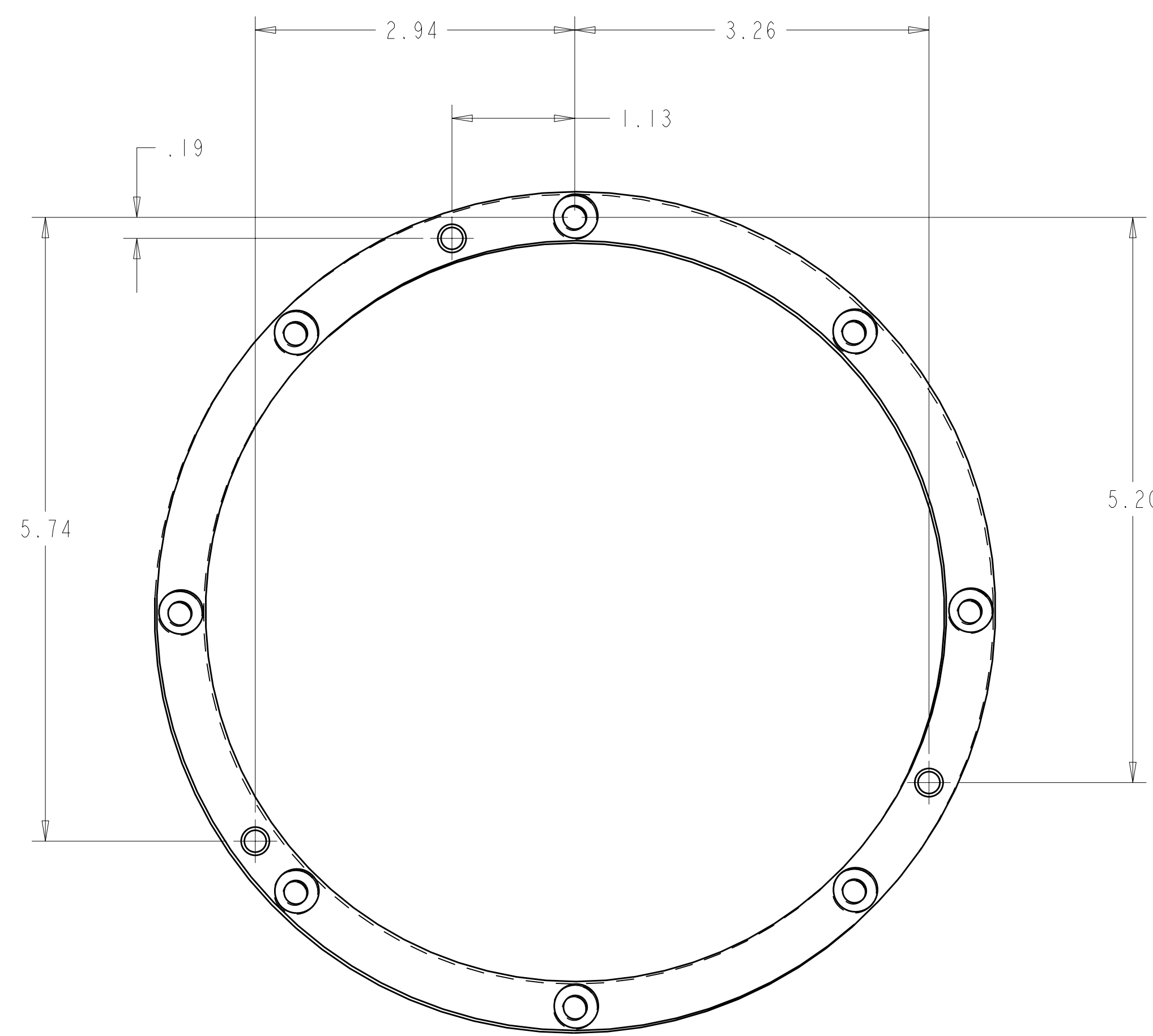

FLAT ORIENTATION

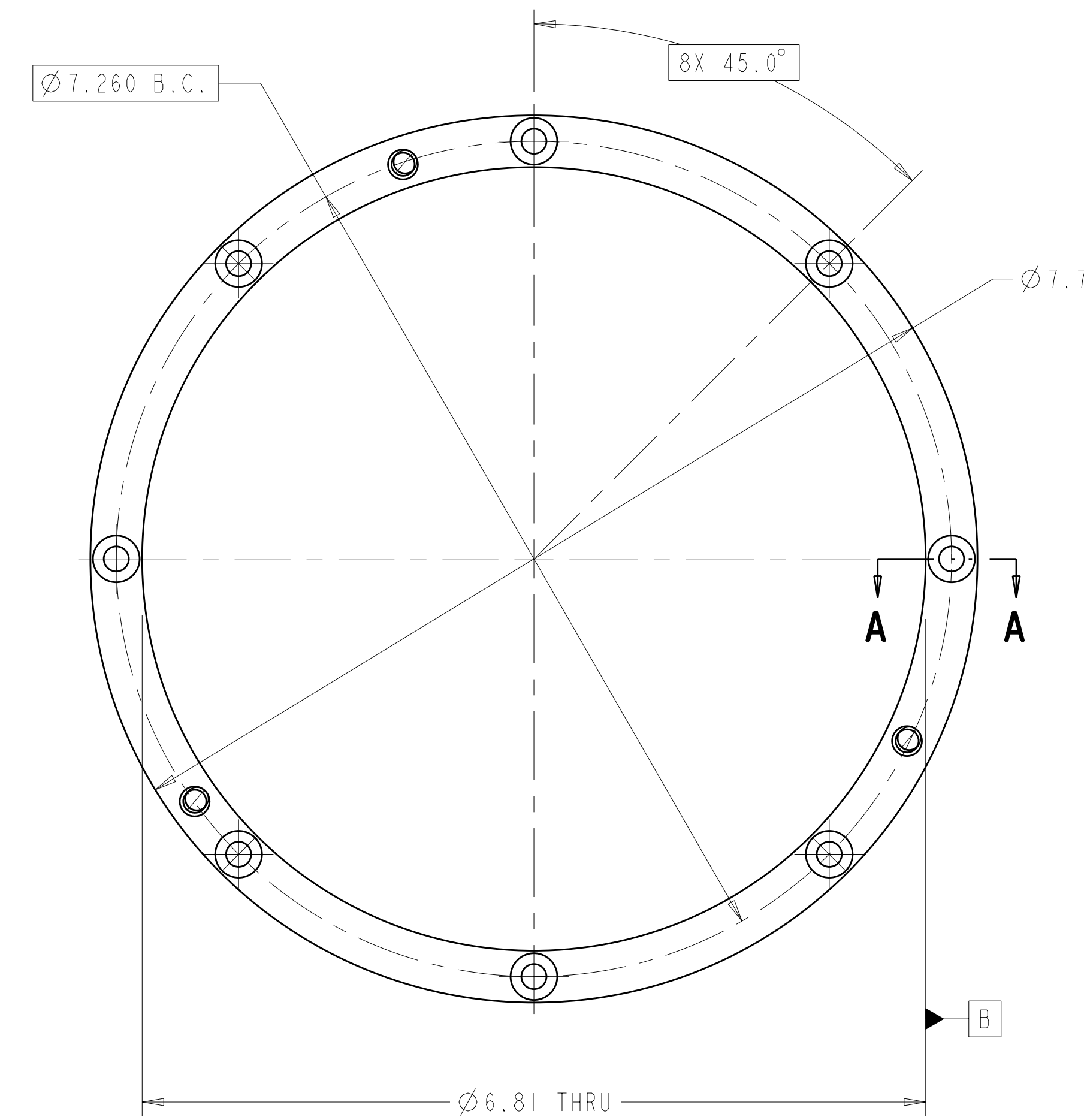
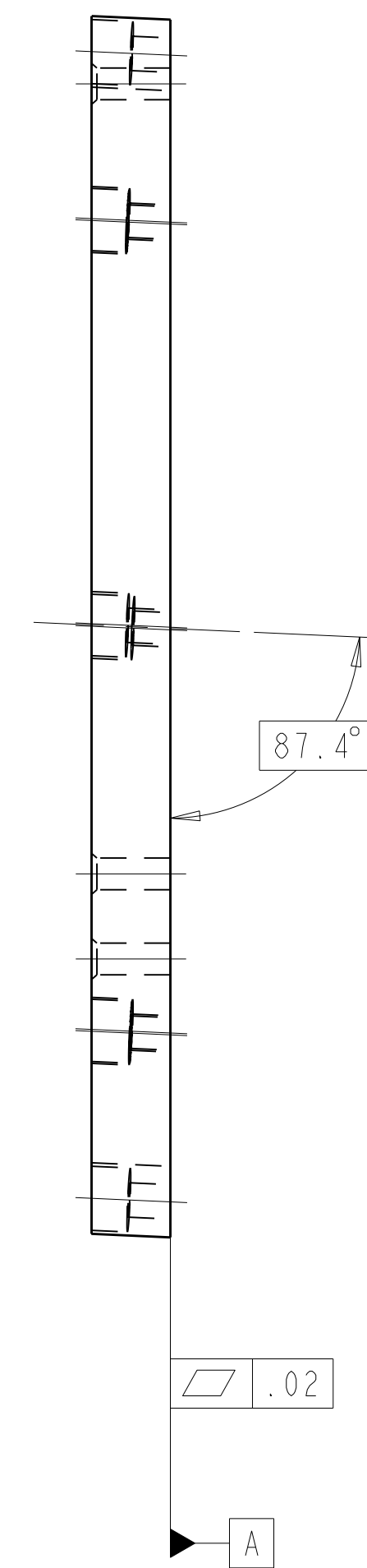

INSTALLED ORIENTATION

-1 PORT 8 WINDING FORM SEAL OUTER PLATE 4  
SCALE 0.083

AR	CAGE CODE	PART OR IDENTIFYING NO	NOMENCLATURE OR DESCRIPTION	MATERIAL	SPECIFICATION	FIND NO
4	AR	-1	PORT 8 SEAL PLATE	GAROLITE	G-11	1
			PARTS LIST			
			NEXT ASSEMBLY			

NO REPRESENTATION OR WARRANTY, EXPRESSED OR IMPLIED, IS MADE AS TO THE ACCURACY, COMPLETENESS OR USEFULNESS OF THE INFORMATION OR STATEMENTS CONTAINED IN THESE DRAWINGS, OR THAT THE USE OR DISCLOSURE OF ANY INFORMATION, APPARATUS, METHOD OR PROCESS DISCLOSED IN THESE DRAWINGS MAY NOT INFRINGE PRIVATE RIGHTS OF OTHERS. NO LIABILITY IS ASSUMED WITH RESPECT TO THE USE OF, OR FOR DAMAGES RESULTING FROM THE USE OF, ANY INFORMATION, APPARATUS, METHOD OR PROCESS DISCLOSED IN THESE DRAWINGS. DRAWINGS MADE AVAILABLE FOR INFORMATION TO BIDDER ARE NOT TO BE USED FOR OTHER PURPOSES, AND ARE TO BE RETURNED UPON REQUEST OF THE FORWARDING CONTRACTOR.

**P** THIS DRAWING PRODUCED ON PRO-ENGINEER

REV	DESCRIPTION	BY	DATE	CHK	DEPT	DATE	PE	REQ	DATE	ORNL	DOE	DATE
0	ORIGINAL ISSUE	MTR	01/07	SP		01/07						

SCALE NOTED		DES	DATE
TOLERANCES UNLESS OTHERWISE SPECIFIED		P GORANSON	01/07
FRACTIONS		MT BROWN	01/07
XX DECIMALS	±.01	S PARSON	01/07
XXX DECIMALS	±.005		
ANGLES	±0°15'		
BREAK SHARP EDGES OR MAX FINISH	±.025 UNLESS OTHERWISE SPECIFIED		

UT-BATTELLE		Oak Ridge National Laboratory managed for the DEPARTMENT OF ENERGY under U.S. GOVERNMENT contract DE-AC05-00OR22725 UT-BATTELLE, LLC, Oak Ridge, Tennessee	
PROJECT NAME			
NATIONAL COMPACT STELLARATOR EXPERIMENT			
PORT 8 WINDING FORM SEAL PLATE OUTER PLATE			
PPPL DRFT	J SIEGEL	01/07	
VERSION NO.	5+	PLANT	ORNL
BLDG	5700	FL	3
SHT	1	OF	1
TYPE	I	CLASS	U
RELEASE LEVEL	WIP		
		SE122-385	
REV	0		