

SECTION A-A
SCALE 1.00

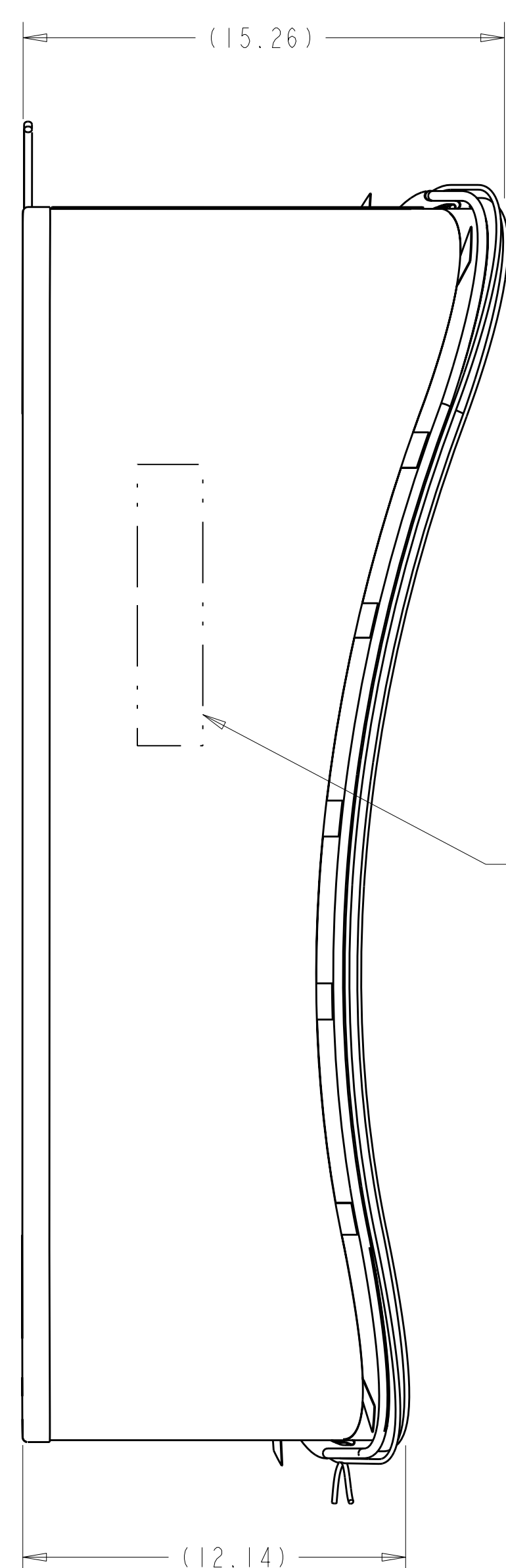

LABEL PART NUMBER AND REVISION
USING PERMANENT INK

-1 PORT 4 SEAL ASSEMBLY
SCALE .25

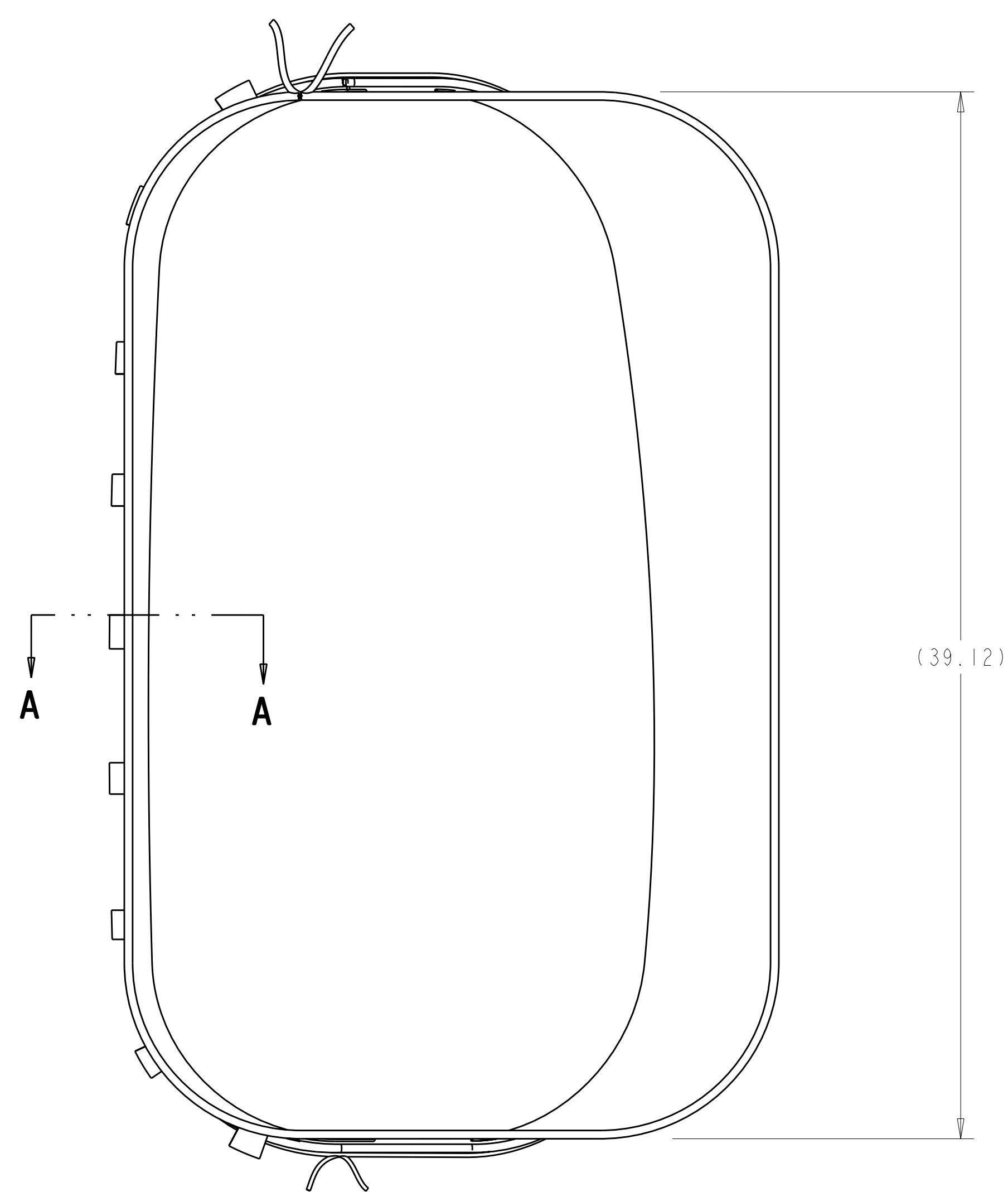
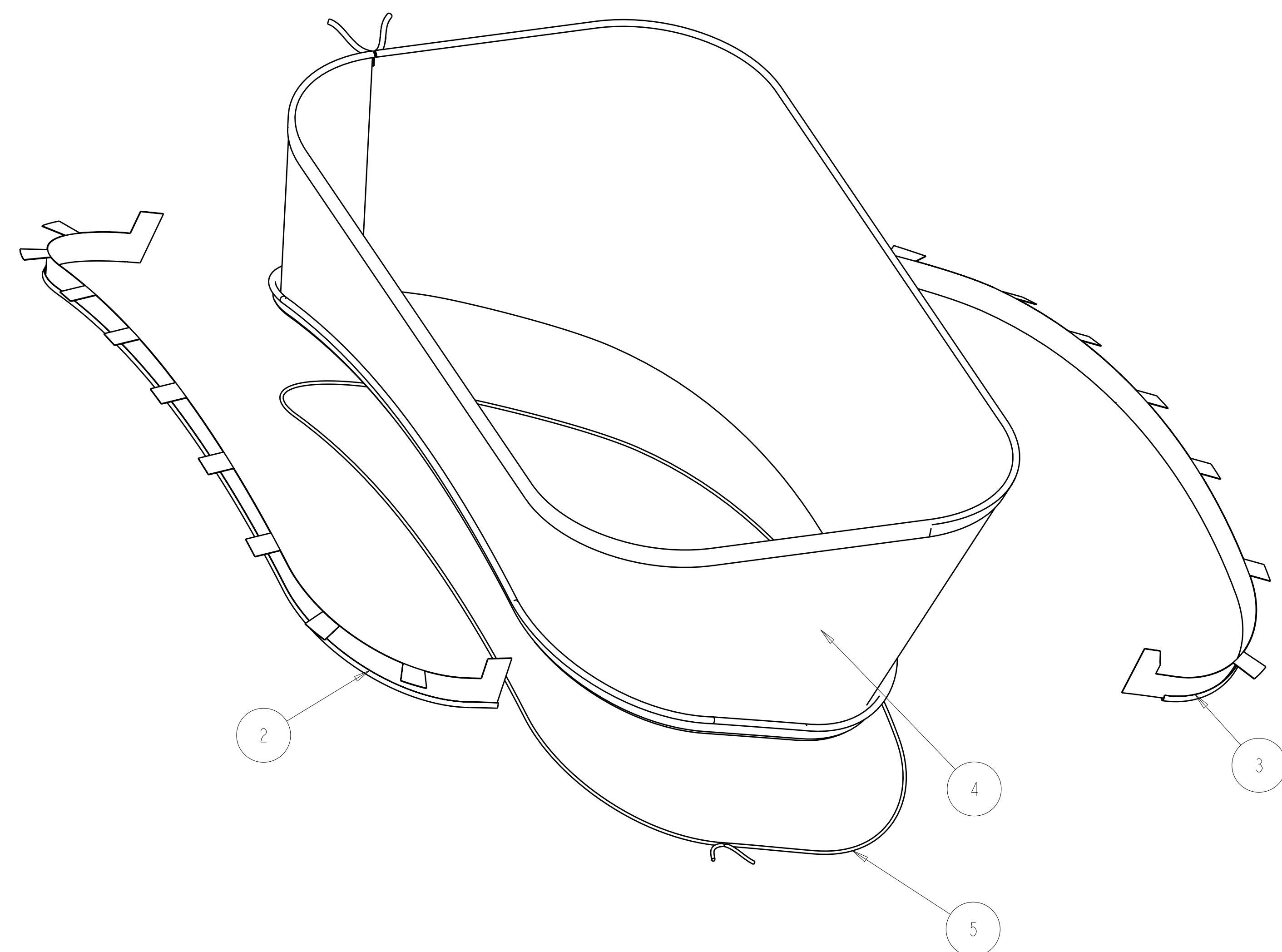

EXPLODED ISOMETRIC VIEW

- NOTES
1. DRAWING PREPARED IN ACCORDANCE WITH ASME Y14.100-2004.
 2. INTERPRET DIMENSIONS AND TOLERANCES PER ASME Y14.5M-1994.
 3. DIMENSIONS ARE IN INCHES

AR	92705K16	.05Ø WIRE	316L ANNEALED	MCMASTER CARR ATLANTA, GA 30374 404-346-1000 WWW.MCMASTER.COM	5	
1	SE122-409-1	PORT 4 SEAL BOOT ASSEMBLY			4	
1	SE122-408-1	PORT 4 SEAL CUFF RIGHT SIDE			3	
1	SE122-407-1	PORT 4 SEAL CUFF LEFT SIDE			2	
AR	-1	PORT 4 SEAL ASSEMBLY			1	
SE122-004-1	CAGE CODE	PART OR IDENTIFYING NO	NOMENCLATURE OR DESCRIPTION	MATERIAL	SPECIFICATION	FIND NO
		NEXT ASSEMBLY				

PARTS LIST

NO REPRESENTATION OR WARRANTY, EXPRESSED OR IMPLIED, IS MADE AS TO THE ACCURACY, COMPLETENESS OR USEFULNESS OF THE INFORMATION OR STATEMENTS CONTAINED IN THESE DRAWINGS, OR THAT THE USE OR DISCLOSURE OF ANY INFORMATION, APPARATUS, METHOD OR PROCESS DISCLOSED IN THESE DRAWINGS MAY NOT INFRINGE PRIVATE RIGHTS OF OTHERS. NO LIABILITY IS ASSUMED WITH RESPECT TO THE USE OF, OR FOR DAMAGES RESULTING FROM THE USE OF, ANY INFORMATION, APPARATUS, METHOD OR PROCESS DISCLOSED IN THESE DRAWINGS. DRAWINGS MADE AVAILABLE FOR INFORMATION TO BIDDER ARE NOT TO BE USED FOR OTHER PURPOSES, AND ARE TO BE RETURNED UPON REQUEST OF THE FORWARDING CONTRACTOR.

P THIS DRAWING PRODUCED ON PRO-ENGINEER

REV	DESCRIPTION	BY	DATE	CHK	DEPT	DATE	PE	REQ	DATE	ORNL	DOE	DATE
0	ORIGINAL ISSUE	GWM	01/07	SP		01/07						
REVISION OR ISSUE PURPOSE												
REVISION APPROVAL												

SCALE NOTED		DES	PL	DRW	CHK	SEC	DEPT	SECT
TOLERANCES UNLESS OTHERWISE SPECIFIED		PL GORANSON		G MCGINNIS	S PARSON			
FRACTIONS								
XX DECIMALS	±.01							
XXX DECIMALS	±.005							
ANGLES	±0°15'							
BREAK SHARP EDGES	OR MAX							
FINISH	.125 UNLESS OTHERWISE SPECIFIED							
DRAWING APPROVALS		PPPL DRFT J SIEGEL	01/07					

VERSION NO.	PLANT	BLDG	FL	SHT	OF	TYPE	CLASS
6+	ORNL	5700	3	1	1	A	U
RELEASE LEVEL		SE122-406		REV 0			
WIP							

Oak Ridge National Laboratory managed for the DEPARTMENT OF ENERGY under U.S. GOVERNMENT contract DE-AC05-00OR22725 UT-BATTELLE, LLC. Oak Ridge, Tennessee

UT-BATTELLE

NATIONAL COMPACT STELLARATOR EXPERIMENT

PORT 4 SEAL ASSEMBLY

SE122-406