

NO.	REVISION	BY	CH	SUP	APPROVED	DATE

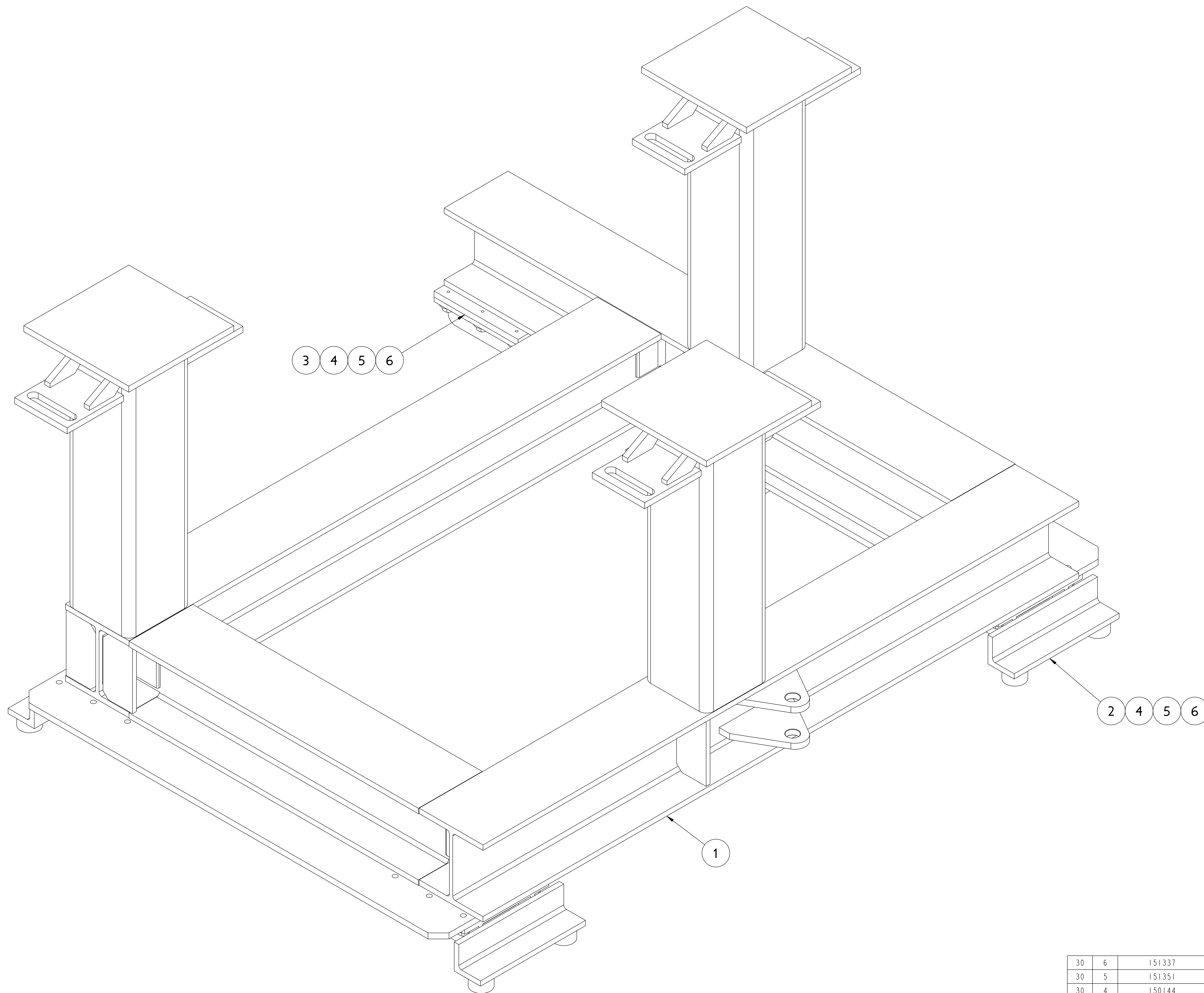

**RELEASED FOR
FABRICATION / INSTALLATION**
 PPPL Drafting

30	6	151337	1/2 SPLIT LOCK WASHER	C" STL - ZN PLT	
30	5	151351	1/2 FLAT WASHER	C" STL - ZN PLT	
30	4	150144	1/2-13UNC-2A x 1" LG HEX HEAD CAP SCREW	C" STL - ZN PLT	
1	3	COMM	HILMAN ROLLER - PRODUCT NO. 8-OT	STEEL	
4	2	COMM	HILMAN ROLLER - PRODUCT NO. 8-OT W/ ACCU-ROLL GUIDE MOUNT	STEEL	
1	1	SE186-330	MCWF RIGHT SIDE SUPPORT CART WELDMENT	SEE DWG	
1	1	THIS DWG	MCWF RIGHT SIDE SUPPORT CART ASSEMBLY		1
01	PART	DRAWING NO.	NOMENCLATURE	MATERIAL	QTY
ASSY	NO.		OR DESCRIPTION		REQD

PARTS LIST

COMPUTER GENERATED DRAWING MANUAL CHANGES NOT PERMITTED Pro E	CENTRAL FILES: UNLESS OTHERWISE SPECIFIED	PRINCETON PLASMA PHYSICS LABORATORY PRINCETON UNIVERSITY	
	DIMENSIONS ARE IN INCHES MACHINE SURFACES UNLESS OTHERWISE SPECIFIED	NATIONAL COMPACT STELLARATOR EXPERIMENT	
DO NOT VERIFY INFORMATION BY SCALING DRAWING	TOLERANCES NON-CUMULATIVE DECIMAL-INCH FRACTIONS .XX ±.000 0"-.125" ±.0010 .XXX ±.005 1/2"-.125" ±.0010 ANGULAR ±.0°-.15° OVER 120° ±.1°	DSN: J. RUSHINSKI 8-2-2007 CHK: M. COLE 8-2-2007 ENGR: T. BROWN 8-2-2007 SUPV: J. SIEGEL 8-2-2007	DRAWING NO: SE186-315 SHEET 1 OF 1 REV 0

RELEASE LEVEL: Fabrication
DWG VERSION NO: 26

NCSX-SE186-315