

NO.	REVISION	BY	CH	SUP	APPROVED	DATE

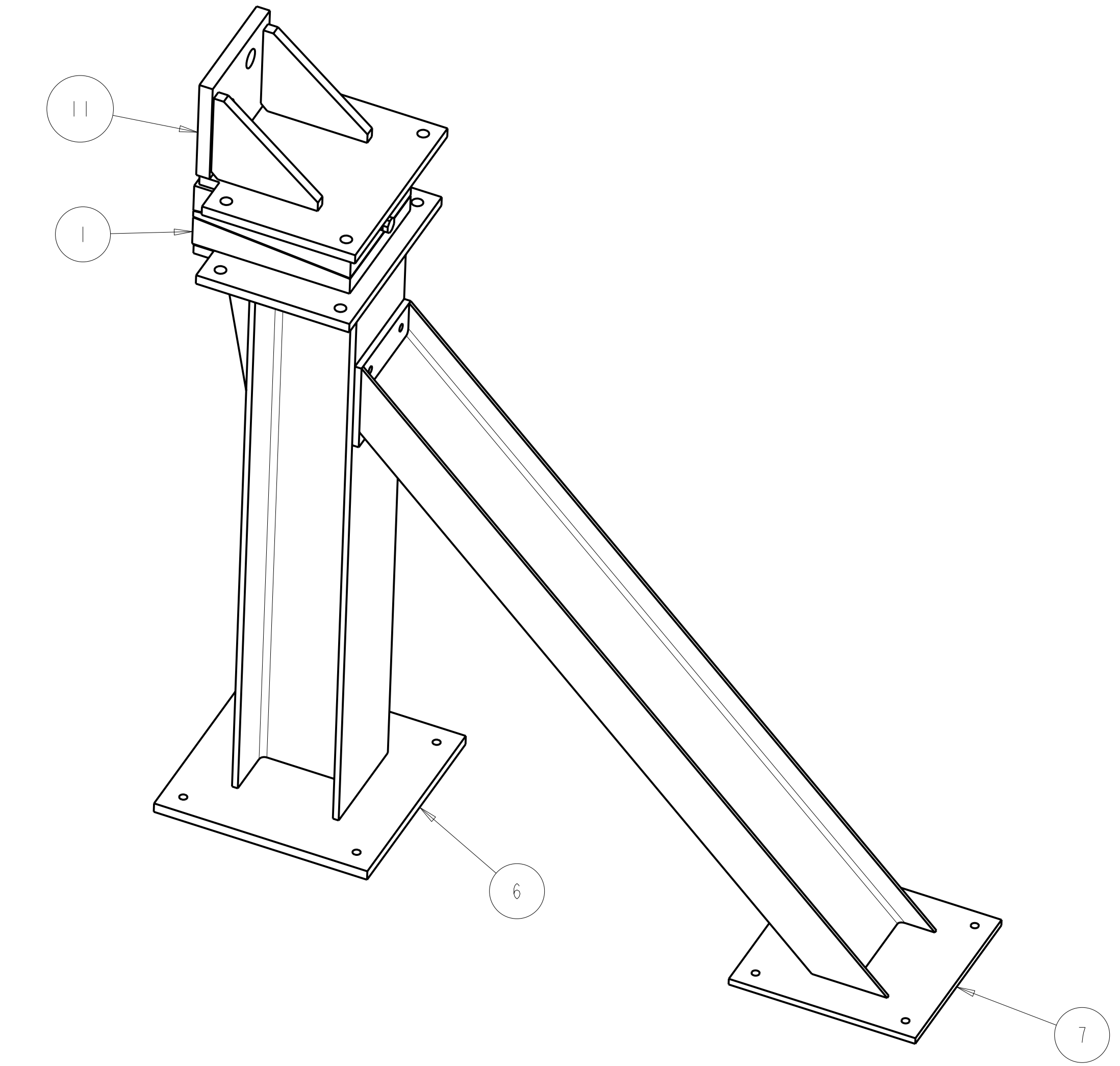
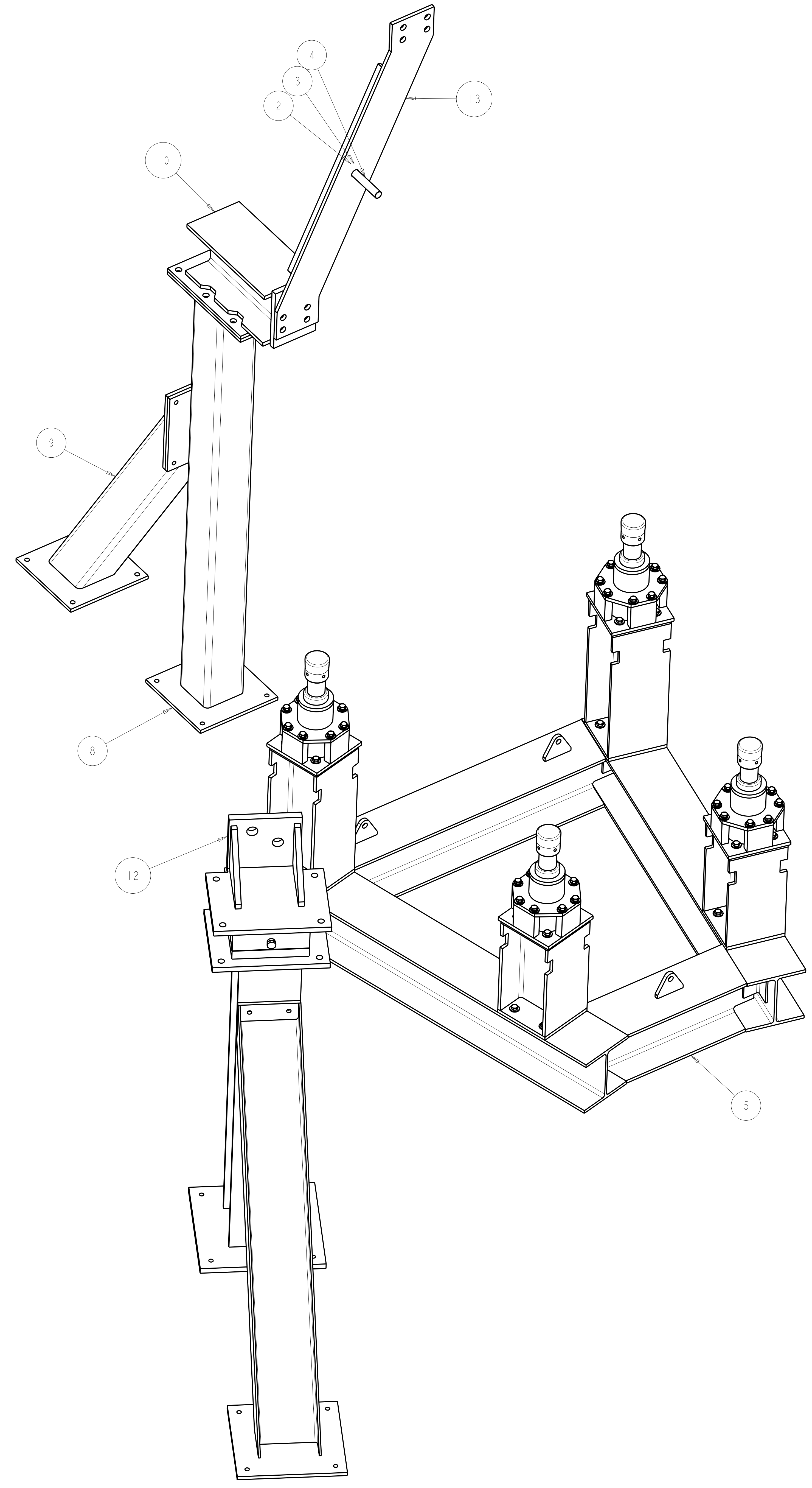

PART NO.	DRAWING NO.	NOMENCLATURE OR DESCRIPTION	MATERIAL	QTY	RECD
13	SE185-382-01	VV TO MC SECURING BAR WELDMENT		1	
12	SE185-381-01	TYPE "C" LOCAL SUPPORT BRACKET - OPPOSITE	--	1	
11	SE185-380-01	TYPE "C" LOCAL SUPPORT BRACKET - AS SHOWN	--	1	
10	SE185-379-01	HORIZONTAL SUPPORT BEAM WELDMENT		1	
9	SE185-378-01	VERTICAL SUPPORT POST OUTRIGGER - NOT USED		1	
8	SE185-377-01	VERTICAL SUPPORT POST WELDMENT	ASTM A36	1	
7	SE185-376-01	VERTICAL SUPPORT POST OUTRIGGER WELDMENT	ASTM A36	2	
6	SE185-375-01	SUPPORT POST	ASTM A36	2	
5	SE185-250	FPA SUPPORT ASSEMBLY	--	1	
4	LM_SE185-HHCS.1.6	1-8 UNC x 6 HEX HEAD BOLT	STEEL - ZN PLT	1	
3	151372	1" SPLIT LOCK WASHER	C" STL - ZN PLT	1	
2	151355	1" FLAT WASHER	C" STL - ZN PLT	1	
1	410.1-VRKC	AIRLOC WEDGEMOUNT PRECISION LEVELER # 410.1-VRKC	STEEL	2	

COMPUTER GENERATED DRAWING MANUAL CHANGES NOT PERMITTED		CENTRAL FILES:	PRINCETON PLASMA PHYSICS LABORATORY NATIONAL COMPACT STELLARATOR EXPERIMENT	
WEIGHT	44184.9 lbs	UNLESS OTHERWISE SPECIFIED	SRJJYUFR FUKKYUF ETXKJETYKJ	
MODEL NAME	SE185-383	DIMENSIONS ARE IN INCHES MACHINE SURFACES BREAK SHARP EDGES .005/.020	DSN: R. UPCAVAGE	DRAWING NO: SE185-383
RELEASE LEVEL: WIP DWG VERSION NO: 3	WELDING ENGINEER	TOLERANCES - NON-CUMULATIVE DECIMAL - INCH FRACTIONS X +/- .100 0" - 12" +/- .010 XX +/- .030 12" - 32" +/- .010 XXX +/- .005 32" - 120" +/- .010 ANGULAR +/- .05 15' OVER 120" +/- .10	CHK: ENGR: T. BROWN	SHEET 1 OF 1 REV 0

NCSX-SE185-383

K