

NO.	REVISION	BY	CH	SUP	APPROVED	DATE

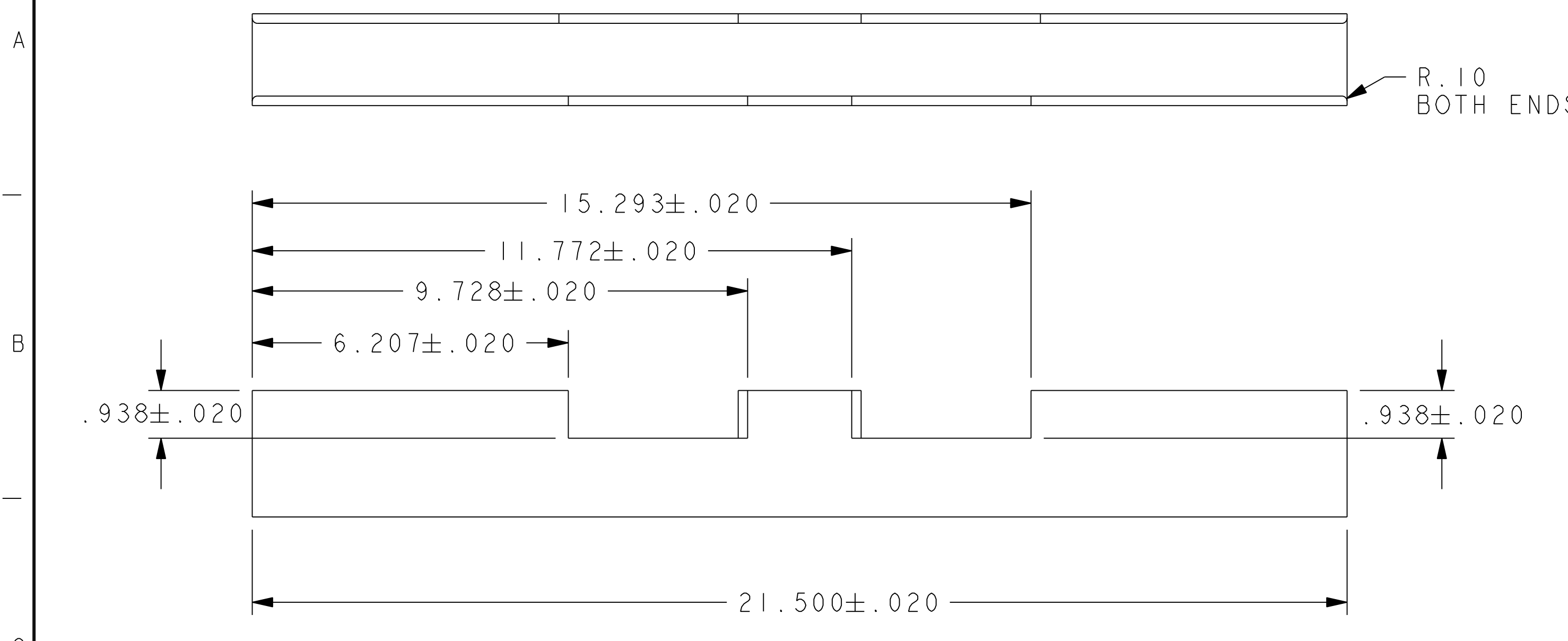

1

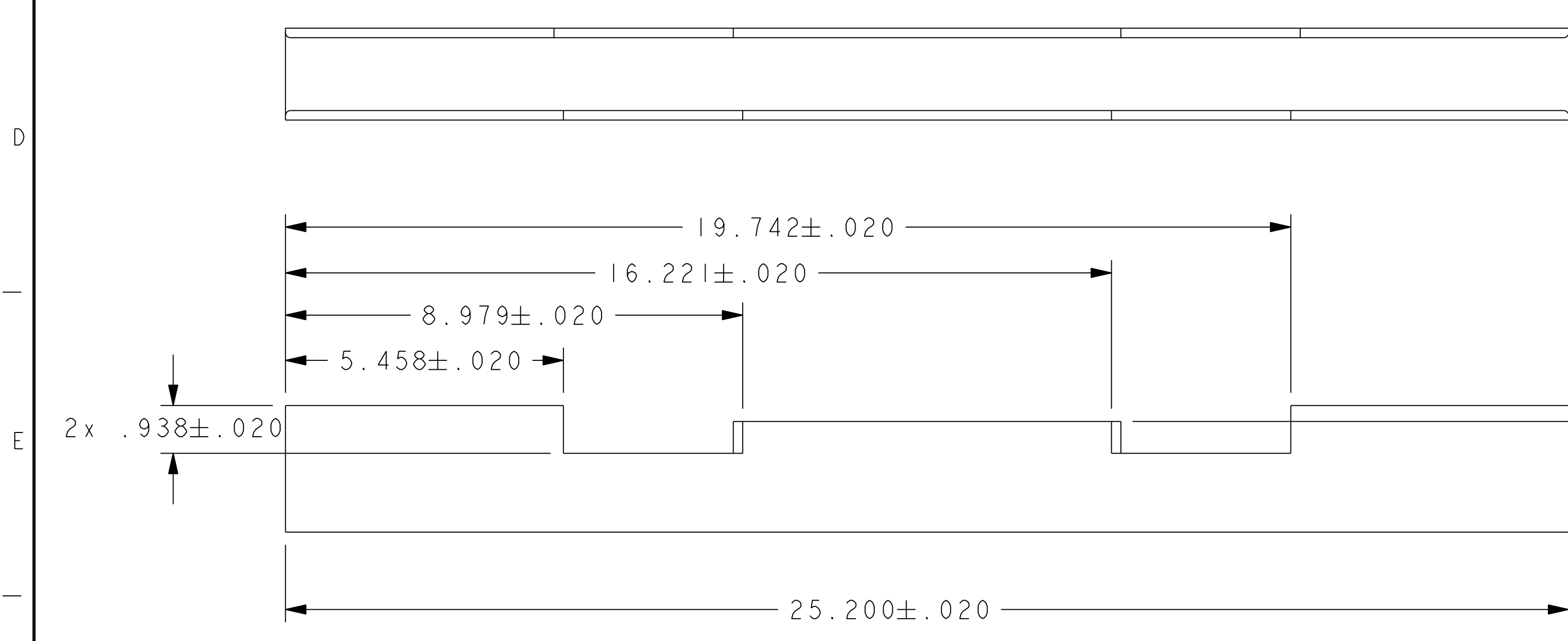
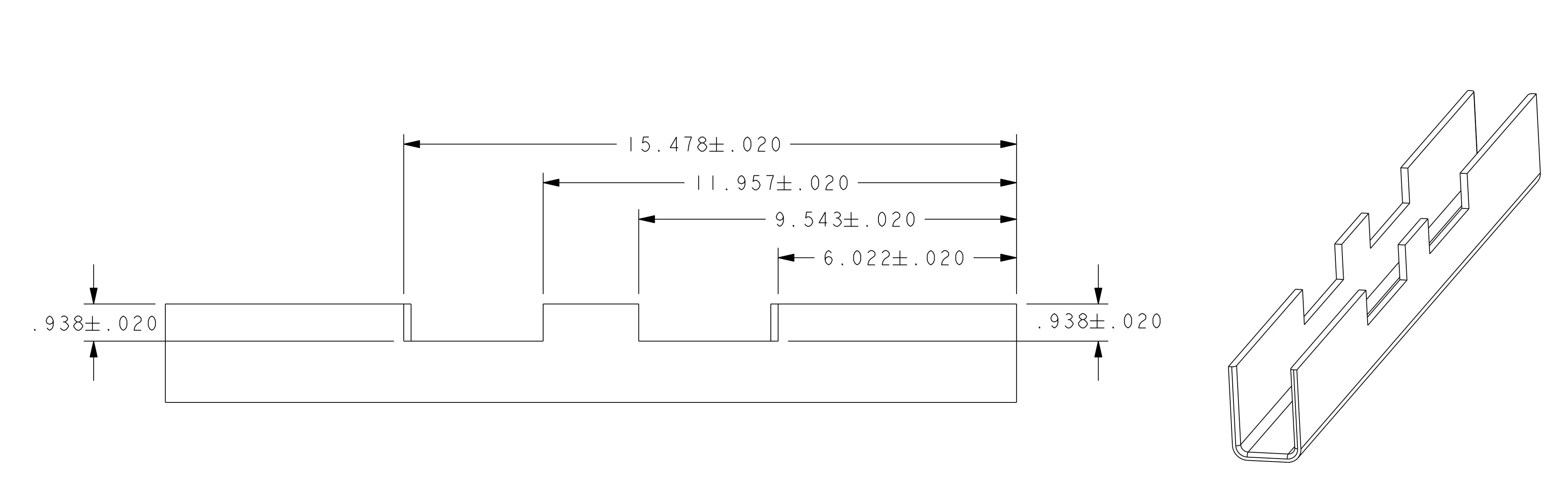

2

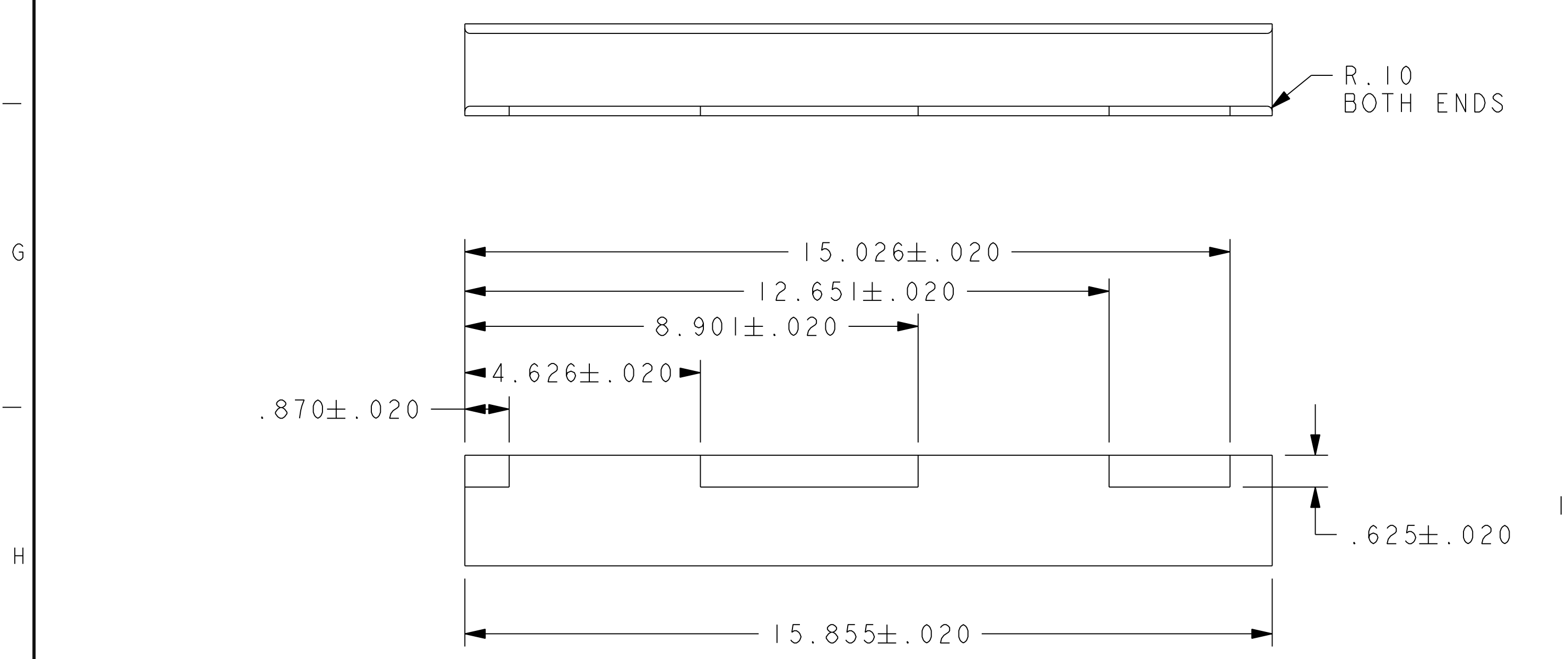
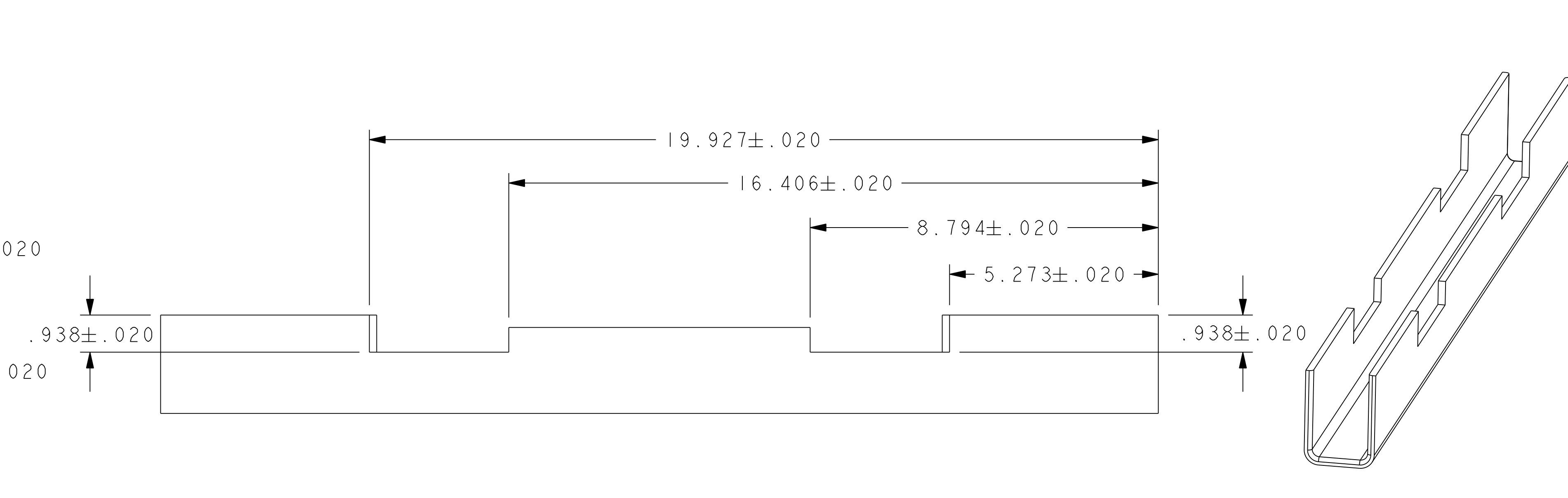

3

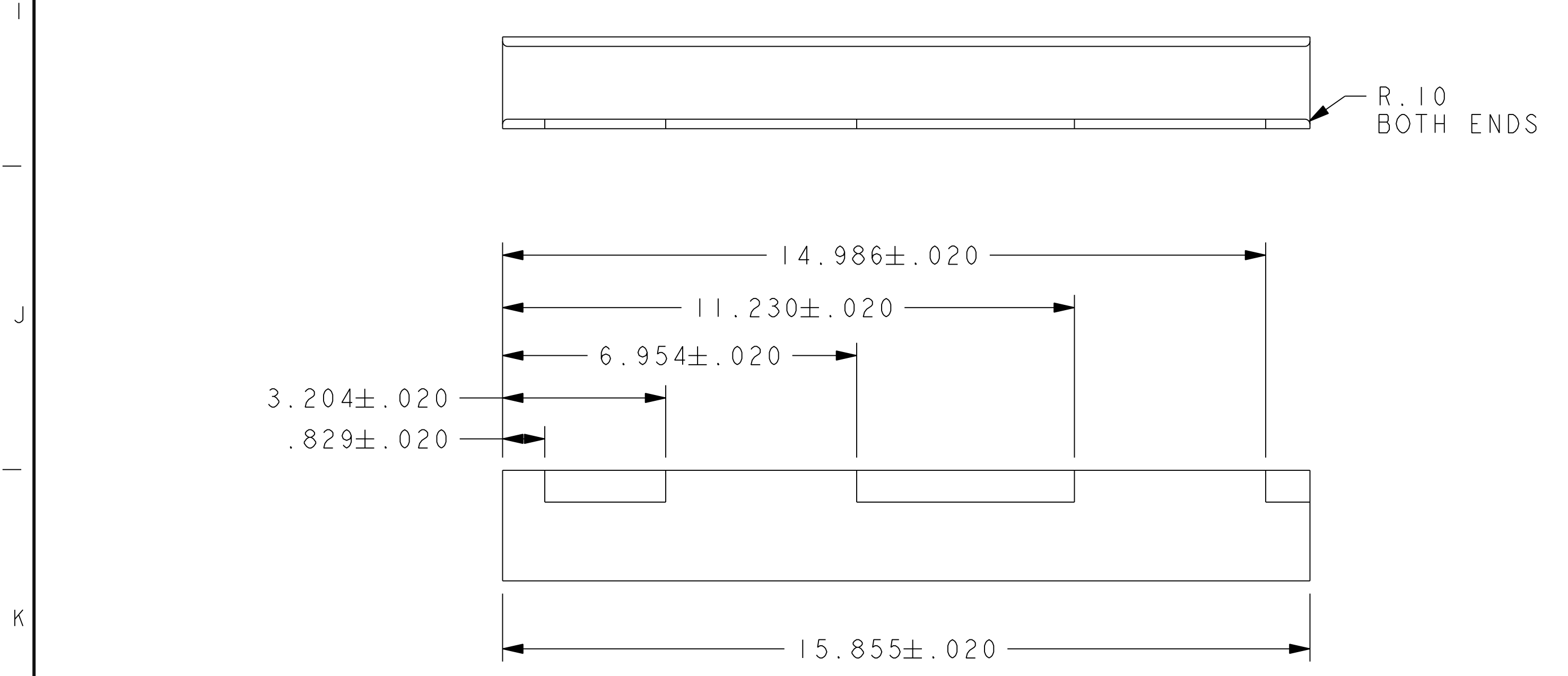
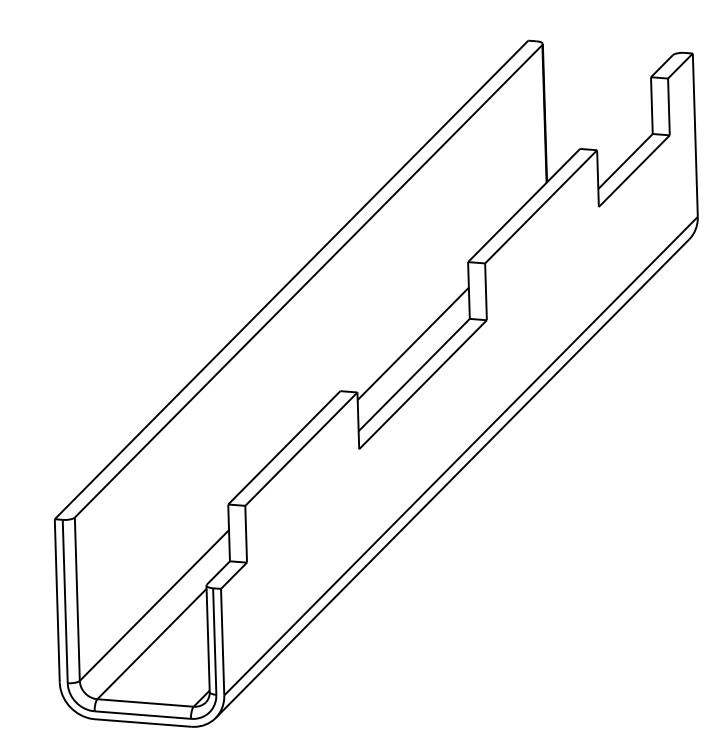

4

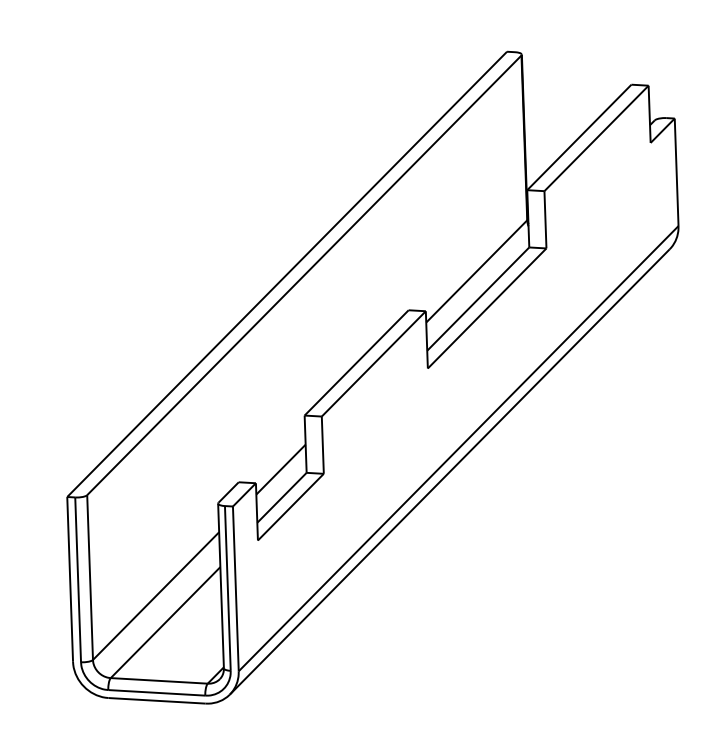

NOTES:
 1. BREAK ALL SHARP CORNERS WITH A .020" MINIMUM RADIUS.
 2. VENDOR TO CERTIFY THAT STOCK MATERIAL EXHIBITED MAGNETIC PERMEABILITY OF LESS THAN 1.02 Mu.
 3. IF AFTER WORKING OR MACHINING PART HAS MAGNETIC PERMEABILITY GREATER THAN 1.02 Mu, THEN PART IS TO BE VACUUM HEAT TREATED AT 1100°C FOR 2.5 HRS TO BRING THE MAGNETIC PERMEABILITY BELOW 1.02 Mu.

PART NO.	DRAWING/MODEL NO	NOMENCLATURE OR DESCRIPTION	MATERIAL	QTY RECD
3	SEI33-044-4	TRIM COIL #1, CHANNEL SUPPORT CAP #4	316 SS/STL	24
3	SEI33-044-3	TRIM COIL #1, CHANNEL SUPPORT CAP #3	316 SS/STL	24
2	SEI33-044-2	TRIM COIL #1, CHANNEL SUPPORT CAP #2	316 SS/STL	12
1	SEI33-044-1	TRIM COIL #1, CHANNEL SUPPORT CAP #1	316 SS/STL	12

COMPUTER GENERATED DRAWING		CENTRAL FILES:		PRINCETON PLASMA PHYSICS LABORATORY	
MANUAL CHANGES NOT PERMITTED	Pro E	UNLESS OTHERWISE SPECIFIED	NATIONAL COMPACT STELLARATOR EXPERIMENT		
DO NOT VERIFY INFORMATION BY SCALING DRAWING	Pro E	BREAK SHARP EDGES .005/.020	STELLARATOR CORE TRIM COILS		
NEXT ASSEMBLY	TOLERANCES NON-CUMULATIVE	DECIMAL-INCH FRACTIONS	DSN: R. UPCAUGE	6/9/08	DRAWING NO:
WEIGHT	4.5 lbs	MODEL NAME	SEI33-044-4	ENGR: M. KALISH	6/9/08
WELDING ENGINEER	RELEASE LEVEL: Fabrication	DWG VERSION NO: 14	SUPV: J. SIEGEL	6/9/08	SHEET 1 OF 1
					REV 0.5

NCSX-SEI33-044

NCSX-PART-FORMAT.E