

NO.	REVISION	BY	CH	SUP	APPROVED	DATE

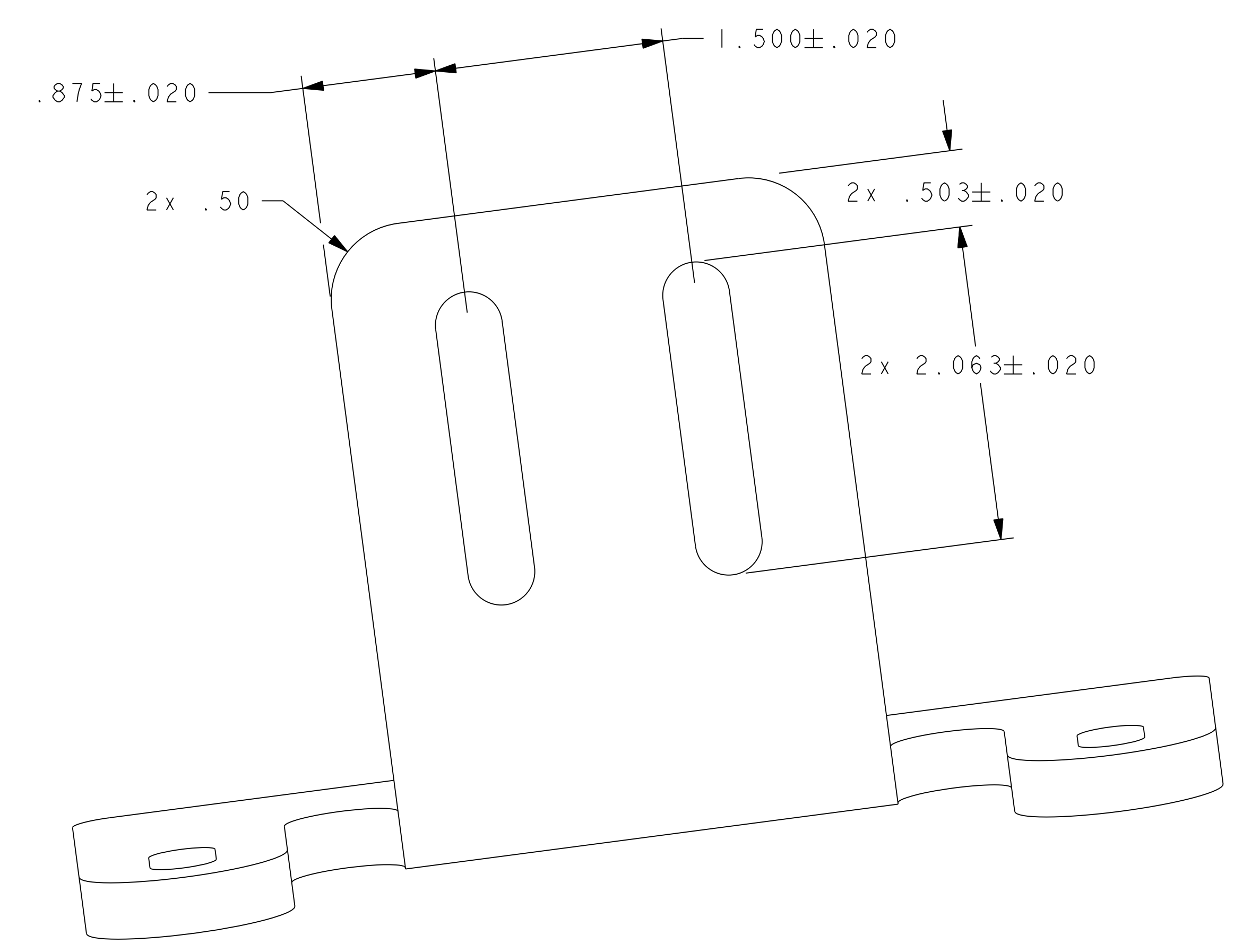
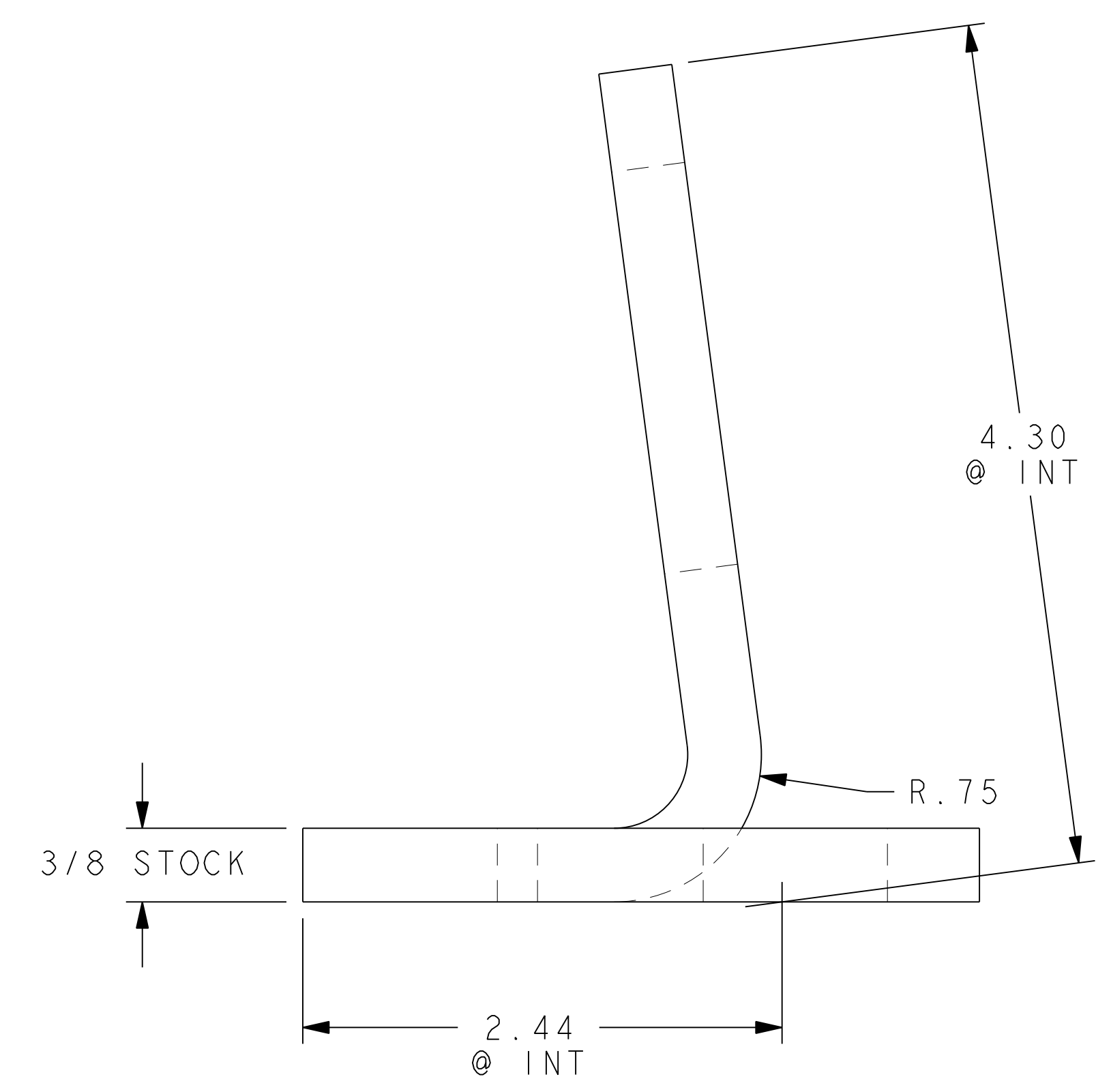
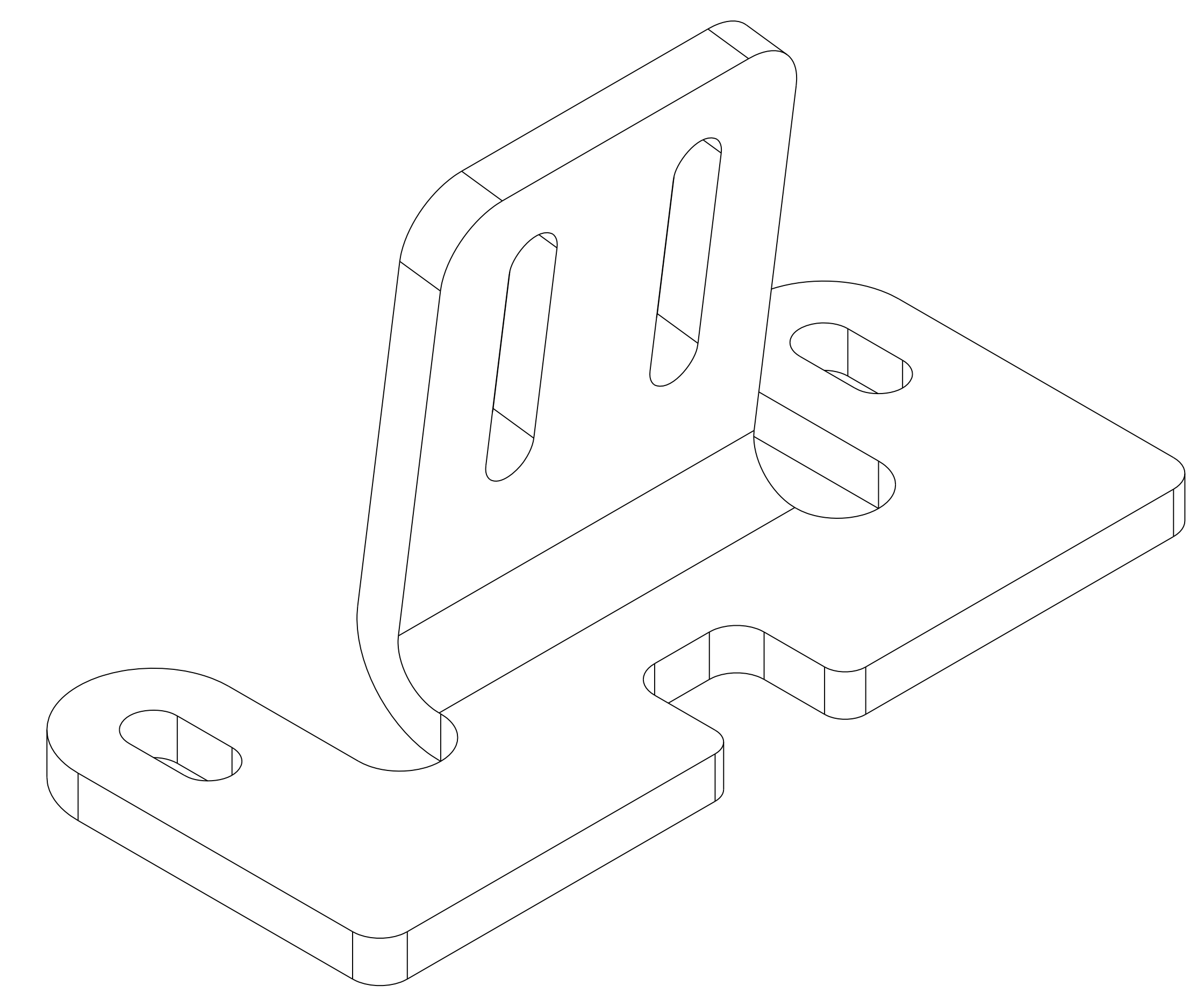
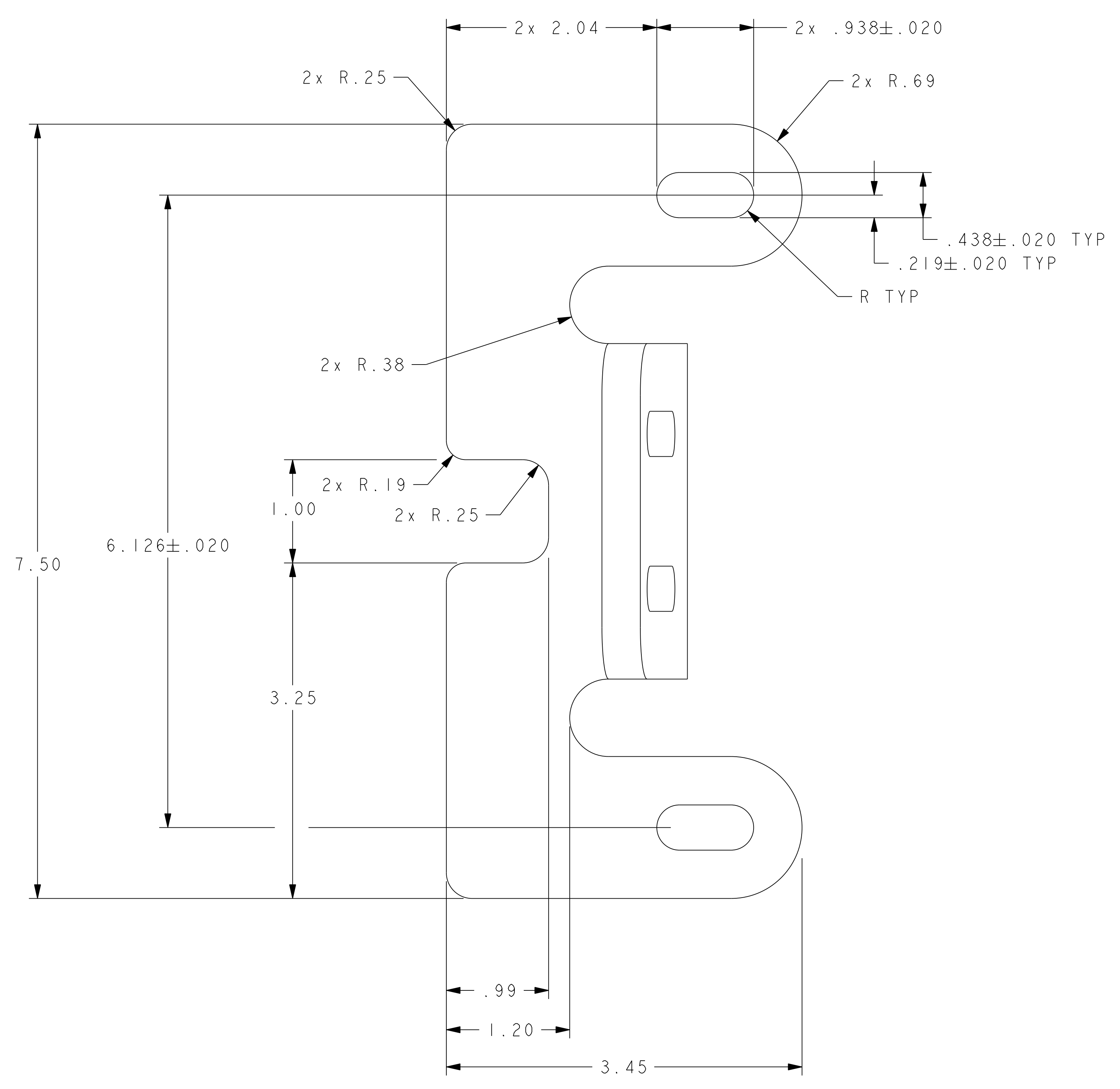

NOTES:  
1. MATERIAL: INCONEL 625, COLD ROLLED 20% REDUCTION, 110 KSI YIELD.

RELEASE LEVEL: Fabrication  
DWG VERSION NO: 14

WEIGHT	2.9 lbs
MODEL NAME	SE133-047-4
WELDING ENGINEER	

COMPUTER GENERATED DRAWING MANUAL CHANGES NOT PERMITTED Pro E	CENTRAL FILES: UNLESS OTHERWISE SPECIFIED	PRINCETON PLASMA PHYSICS LABORATORY PRINCETON UNIVERSITY <b>NATIONAL COMPACT STELLARATOR EXPERIMENT</b>			
DO NOT VERIFY INFORMATION BY SCALING DRAWING	BREAK SHARP EDGES .005/.020	STELLARATOR CORE TRIM COILS TRIM COIL #1 LEFT/RIGHT BRACKET			
NEXT ASSEMBLY	TOLERANCES NON-CUMULATIVE	DSN: R. UPCAVAGE	6/13/08	DRAWING NO:	
	DECIMAL-INCH FRACTIONS	CHK: M. KALISH	6/13/08	SE133-047-4	
	.XX +/- .000 0°-120° +/- 15.0	ENGR: M. KALISH	6/13/08		
	.XXX +/- .005 120°-120° +/- 15.0	SUPV: J. SIEGEL	6/13/08	SHEET 1 OF 1	REV 0
	ANGULAR +/- 0°-15° OVER 120° +/- 15.0				

NCSX-SE133-047-4