

NOTES:
 1. HARDWARE TO EXHIBITE MAGNETIC PERMEABILITY LESS THAN 1.05
 2. A286 MATERIAL YIELD GREATER THAN OR EQUAL TO 180 KSI FOR BOLTS.
 3. BOTH SPRING WASHERS TO BE CUPPED CONVEXED UNDER NUTS "(((" AND TIGHTENED TO FLAT FOR MINIMUM PRE LOAD FORCE OF 5,800 LBS.

PART NO.	DRAWING NO	NOMENCLATURE OR DESCRIPTION	MATERIAL	QTY RECD
16	SE133-074	BRACKET SUPPORT	INCONEL 625	4
15	SE133-073	TRIM COIL WIRE #2	12 GAUGE WIRE	1
14	SE133-072	TRIM COIL WIRE #1	12 GAUGE WIRE	1
13	SE133-071	COIL TO WIRE CONNECTOR	SILICON BRONZE (DURIUM)	2
12	SE133-070	COVER, COIL CONNECTION HOUSING	G10	1
11	SE133-069	COIL CONNECTION HOUSING	G10	1
10	SE133-068-2	INSULATOR #2	G10	4
9	SE133-068-1	INSULATOR #1	G10	8
8	SE133-063-01	TRIM COIL, #1 WELDMENT	SEE DETAILS	1
7	SE133-047-4	TRIM COIL #1 LEFT/RIGHT BRACKET	INCONEL 625	4
6	SE133-047-1	TRIM COIL #1 MIDDLE MOUNTING BRACKET	INCONEL 625	4
5	NS151377	3/8 FLAT WASHER, HEAVY	ALLOY A-286	67
4	NS150280	3/8-16 UNC HEAVY HEX NUT	ALLOY A-286	32
3	NS150176	3/8-16 UNC x 2 1/4 BOLT, HEX HEAD	ALLOY A-286	24
2	NS150175	3/8-16 UNC x 1 3/4 BOLT, HEX HEAD	ALLOY A-286	2
1	6EH89718	3/8 DISC SPRING 2900 LBS (P max) SOLON MANUFACTURING	INCONEL	66

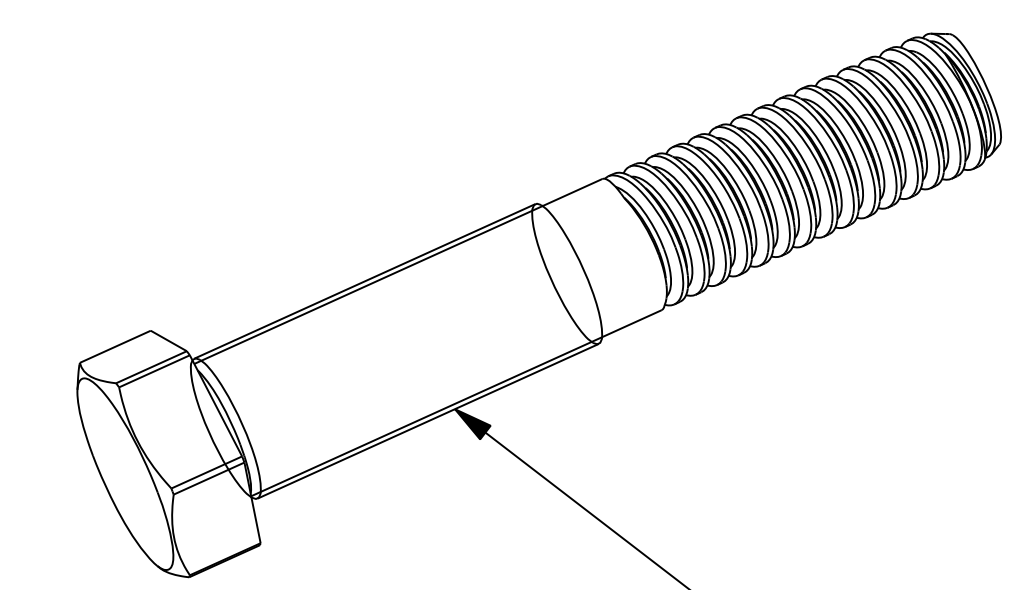

FOR ALL BOLTS ATTACHED TO MOUNTING BRACKETS W/ G10 INSULATOR. ADD TEFLON TAPE TO INSULATE BOLT FROM TOUCHING BRACKETS.

RELEASE LEVEL: Fabrication
 DWG VERSION NO: 29

COMPUTER GENERATED DRAWING MANUAL CHANGES NOT PERMITTED Pro E	CENTRAL FILES: UNLESS OTHERWISE SPECIFIED DIMENSIONS ARE IN INCHES MACHINE SURFACES BREAK SHARP EDGES .005/.020	PRINCETON PLASMA PHYSICS LABORATORY PRINCETON UNIVERSITY NATIONAL COMPACT STELLARATOR EXPERIMENT	
DO NOT VERIFY INFORMATION BY SCALING DRAWING	TOLERANCES NON-CUMULATIVE DECIMAL-INCH FRACTIONS .XX +/- .000 .XXX +/- .005 ANGULAR +/- .015	DSN: R. UPCAVAGE CHK: M. KALISH ENGR: M. KALISH SUPV: J. SIEGEL	6/6/08 6/6/08 6/6/08 6/6/08
WEIGHT 187.4 lbs	MODEL NAME SE133-058	STELLARATOR CORE TRIM COILS TRIM COIL, #1 ASSEMBLY	DRAWING NO: SE133-058
WELDING ENGINEER	NEXT ASSEMBLY	SHEET 1 OF 1	REV 0

NCSX-SE133-058