

NO.	REVISION	BY	CH	SUP	APPROVED	DATE

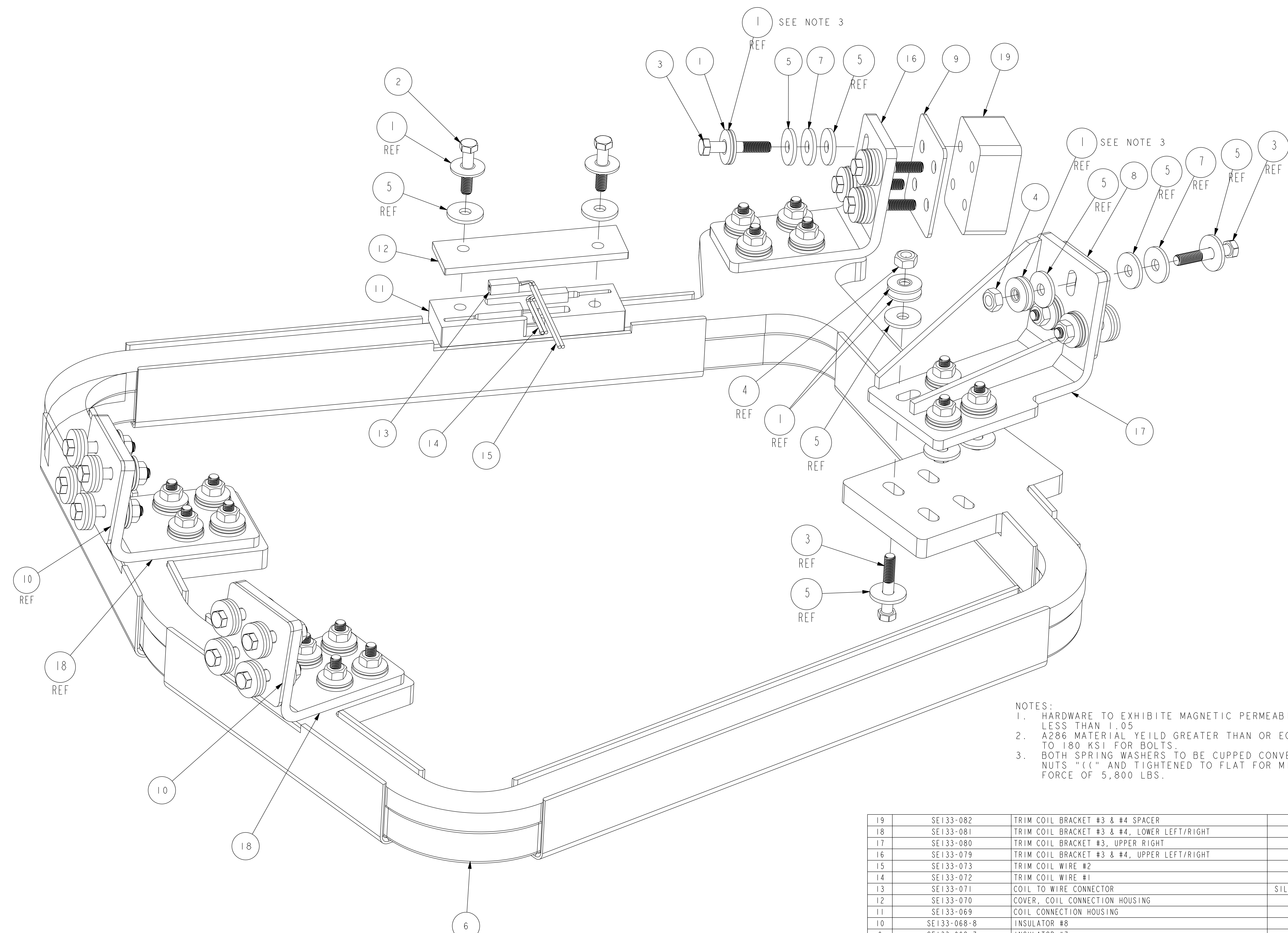

- NOTES:
1. HARDWARE TO EXHIBITE MAGNETIC PERMEABILITY LESS THAN 1.05
 2. A286 MATERIAL YIELD GREATER THAN OR EQUAL TO 180 KSI FOR BOLTS.
 3. BOTH SPRING WASHERS TO BE CUPPED CONVEXED UNDER NUTS "C" AND TIGHTENED TO FLAT FOR MINIMUM PRE LOAD FORCE OF 5,800 LBS.

PART NO.	DRAWING NO	NOMENCLATURE OR DESCRIPTION	MATERIAL	QTY RECD
19	SE133-082	TRIM COIL BRACKET #3 & #4 SPACER	316 SS/STL	1
18	SE133-081	TRIM COIL BRACKET #3 & #4, LOWER LEFT/RIGHT	INCONEL 625	2
17	SE133-080	TRIM COIL BRACKET #3, UPPER RIGHT	INCONEL 625	1
16	SE133-079	TRIM COIL BRACKET #3 & #4, UPPER LEFT/RIGHT	INCONEL 625	1
15	SE133-073	TRIM COIL WIRE #2	12 GAUGE WIRE	1
14	SE133-072	TRIM COIL WIRE #1	12 GAUGE WIRE	1
13	SE133-071	COIL TO WIRE CONNECTOR	SILICON BRONZE (DURIUM)	2
12	SE133-070	COVER, COIL CONNECTION HOUSING	G10	1
11	SE133-069	COIL CONNECTION HOUSING	G10	1
10	SE133-068-8	INSULATOR #8	G10	2
9	SE133-068-7	INSULATOR #7	G10	1
8	SE133-068-6	INSULATOR #6	G10	1
7	SE133-068-1	INSULATOR #1	G10	15
6	SE133-065-01	TRIM COIL, #3 WELDMENT	SEE DETAILS	1
5	NS151377	3/8 FLAT WASHER, HEAVY	ALLOY A-286	75
4	NS150280	3/8-16 UNC HEAVY HEX NUT	ALLOY A-286	27
3	NS150176	3/8-16 UNC x 2 1/4 BOLT, HEX HEAD	ALLOY A-286	31
2	NS150175	3/8-16 UNC x 1 3/4 BOLT, HEX HEAD	ALLOY A-286	2
1	6EH89718	3/8 DISC SPRING 2900 LBS (P max.) SOLON MANUFACTURING	INCONEL	62

PARTS LIST

COMPUTER GENERATED DRAWING CHANGES NOT PERMITTED	CENTRAL FILES: UNLESS OTHERWISE SPECIFIED	PRINCETON PLASMA PHYSICS LABORATORY			
PRO E	DIMENSIONS ARE IN INCHES MACHINE SURFACES UNLESS OTHERWISE SPECIFIED	NATIONAL COMPACT STELLARATOR EXPERIMENT			
DO NOT VERIFY INFORMATION BY SCALING DRAWING	BREAK SHARP EDGES .005/.020	STELLARATOR CORE TRIM COILS			
NEXT ASSEMBLY	TOLERANCES NON-CUMULATIVE	DSN: R. UPKAVAGE	6/9/08	DRAWING NO:	
	DECIMAL-INCH FRACTIONS	CHK: M. KALISH	6/9/08	SE133-060	
	.XX +/- .000 0"-.125" +/- .010	ENGR: M. KALISH	6/9/08		
	.XXX +/- .005 12"-.120" +/- .114	SUPV: J. SIEGEL	6/9/08	SHEET 1 OF 1	
	ANGULAR +/- .015			REV 0	

RELEASE LEVEL: Fabrication
DWG VERSION NO: 31

WEIGHT
301.2 lbs

MODEL NAME
SE133-060

FOR ALL BOLTS ATTACHED TO MOUNTING BRACKETS W/ G10 INSULATOR. ADD TEFLON TAPE TO INSULATE BOLT FROM TOUCHING BRACKETS.

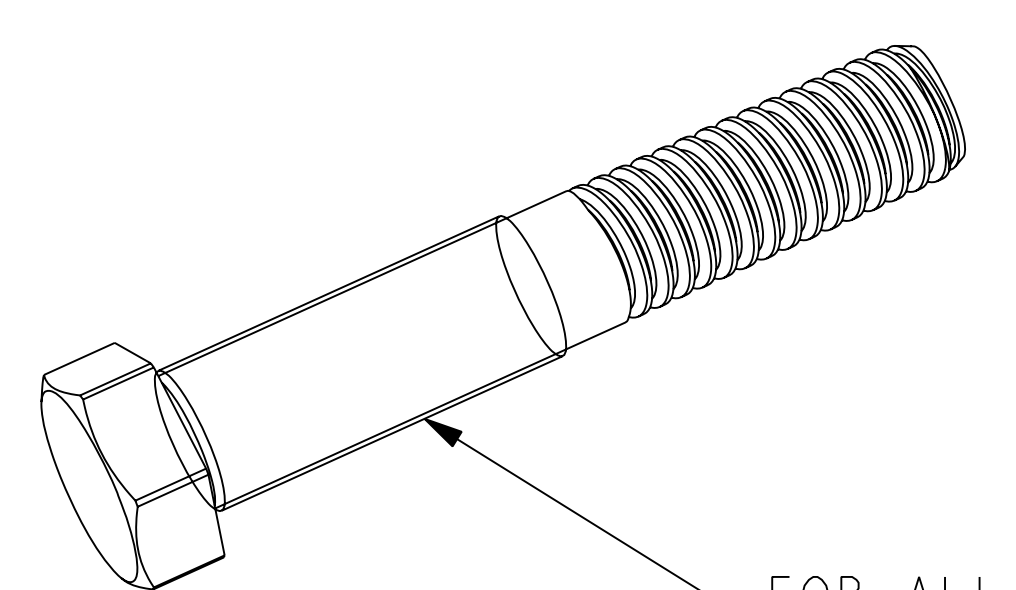

NCSX-SE133-060