

NO.	REVISION	BY	CH	SUP	APPROVED	DATE

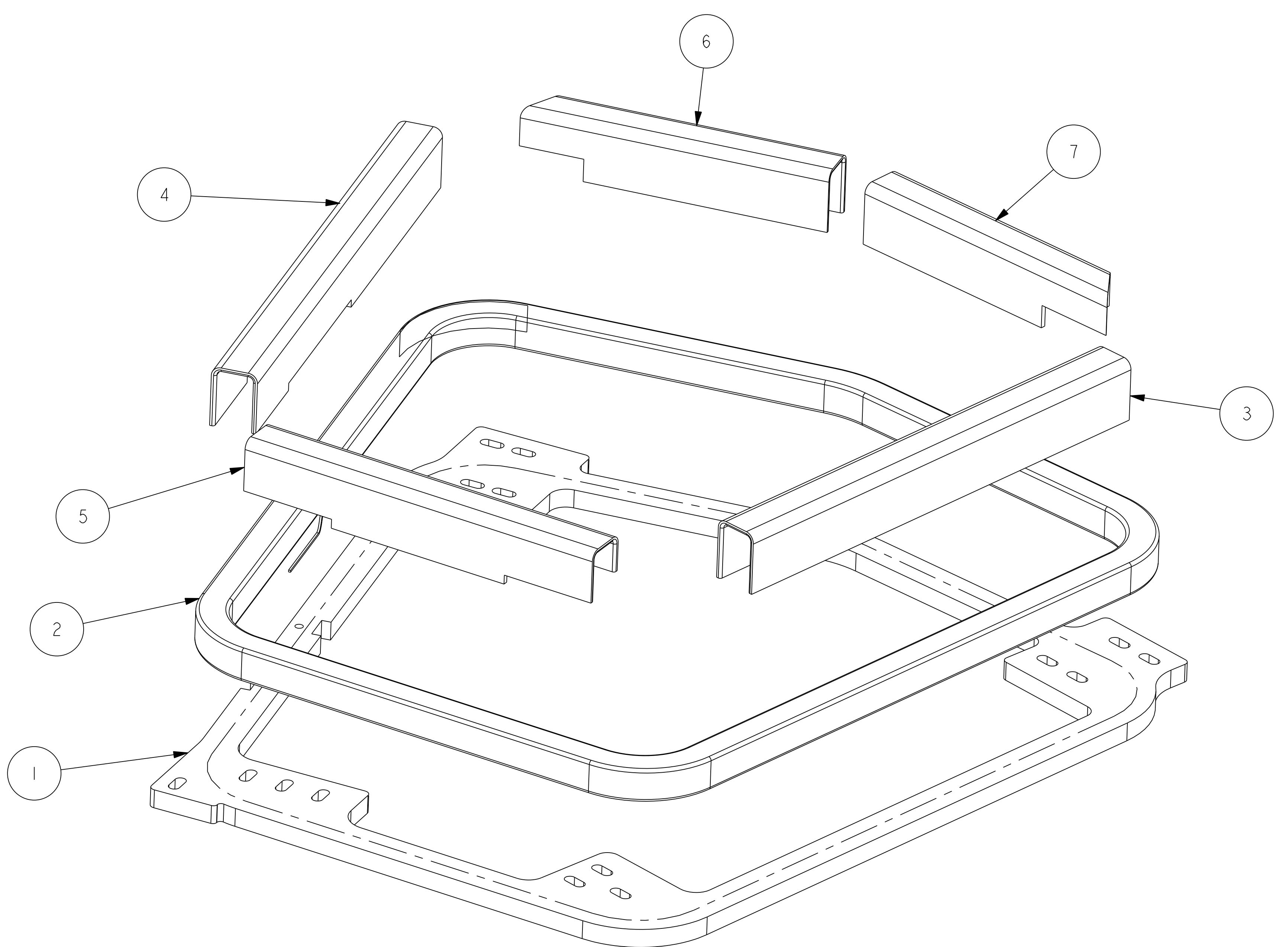

GMAW - SEE NOTE 1 & NOTE 4

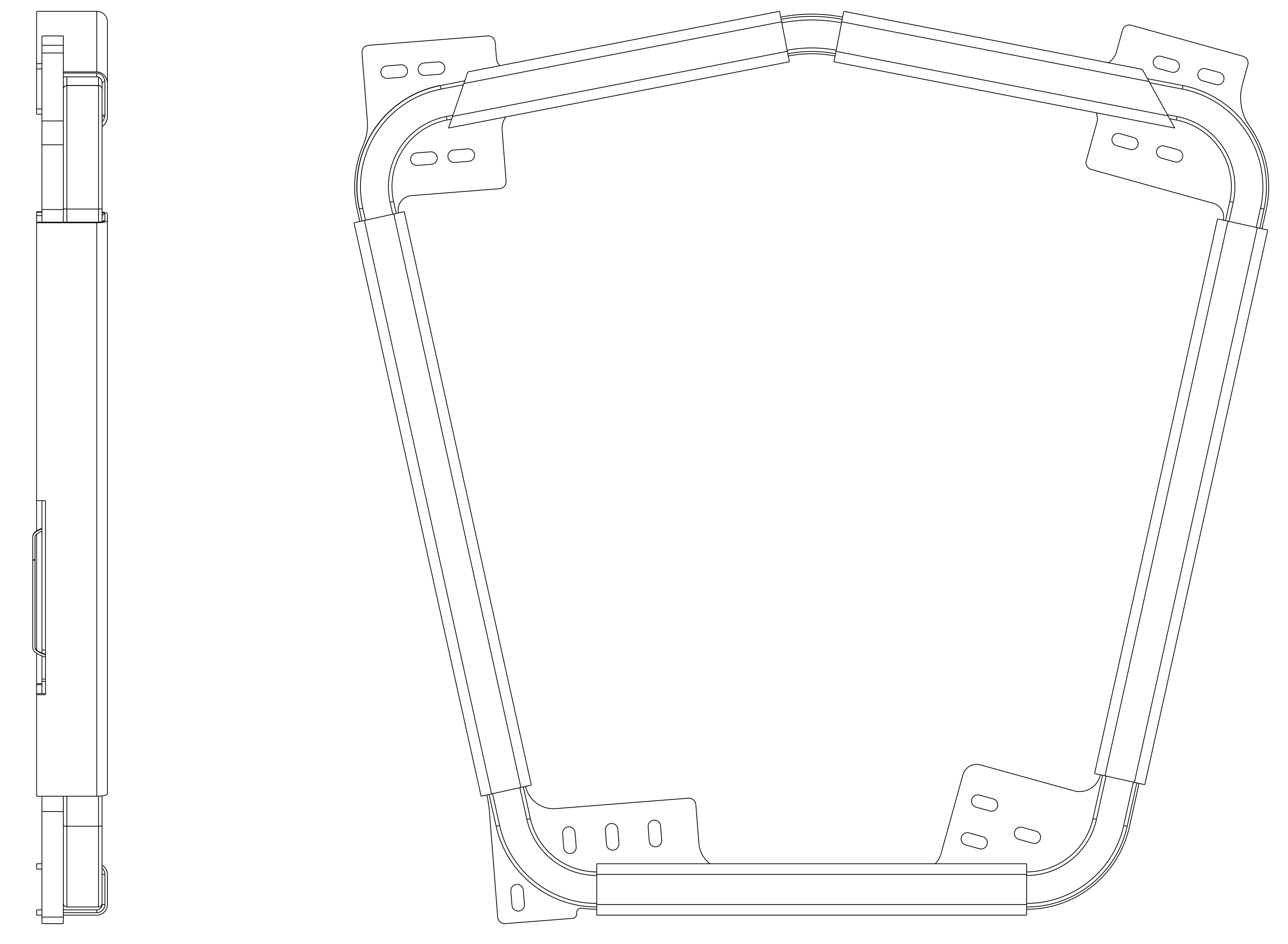
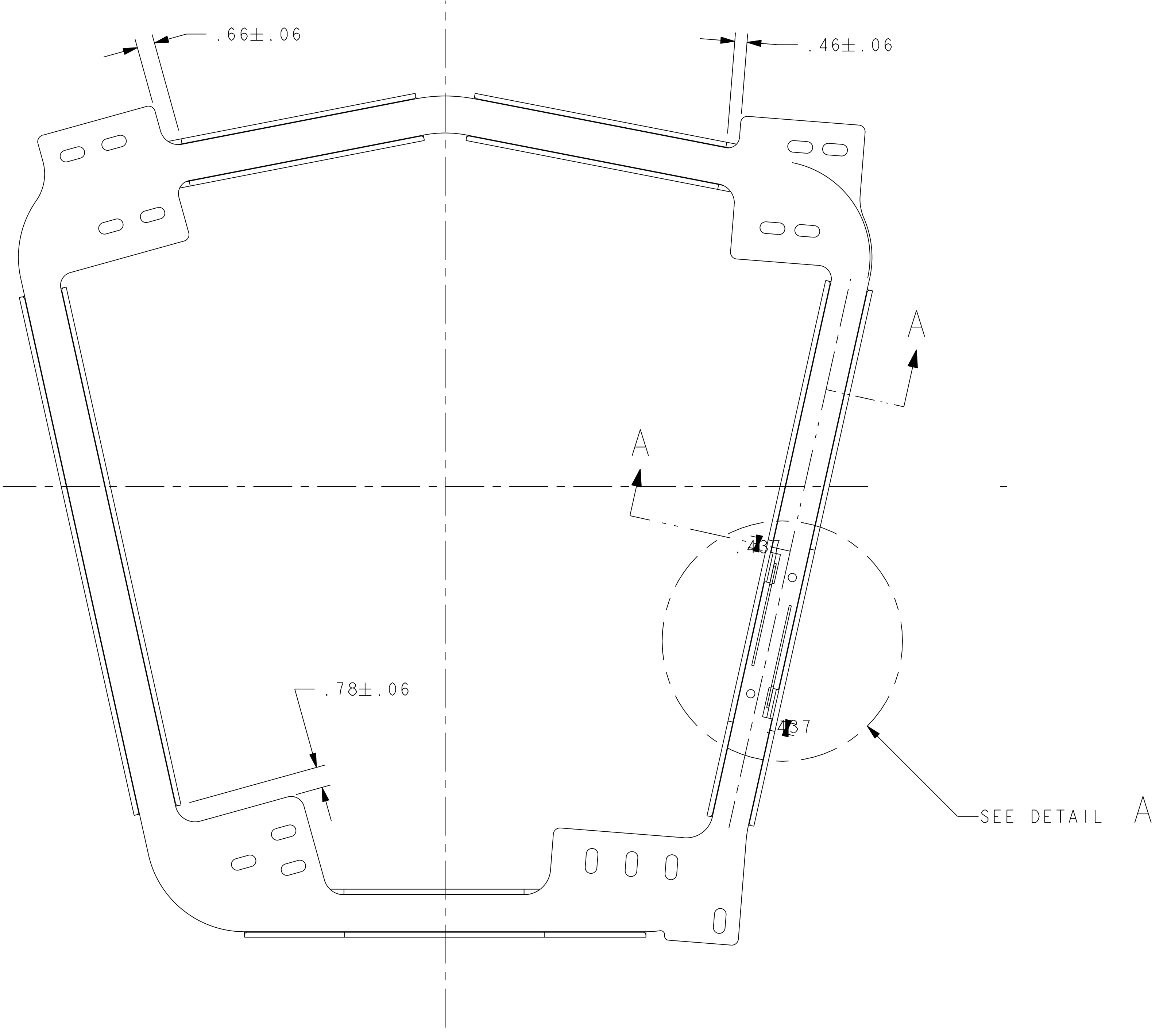
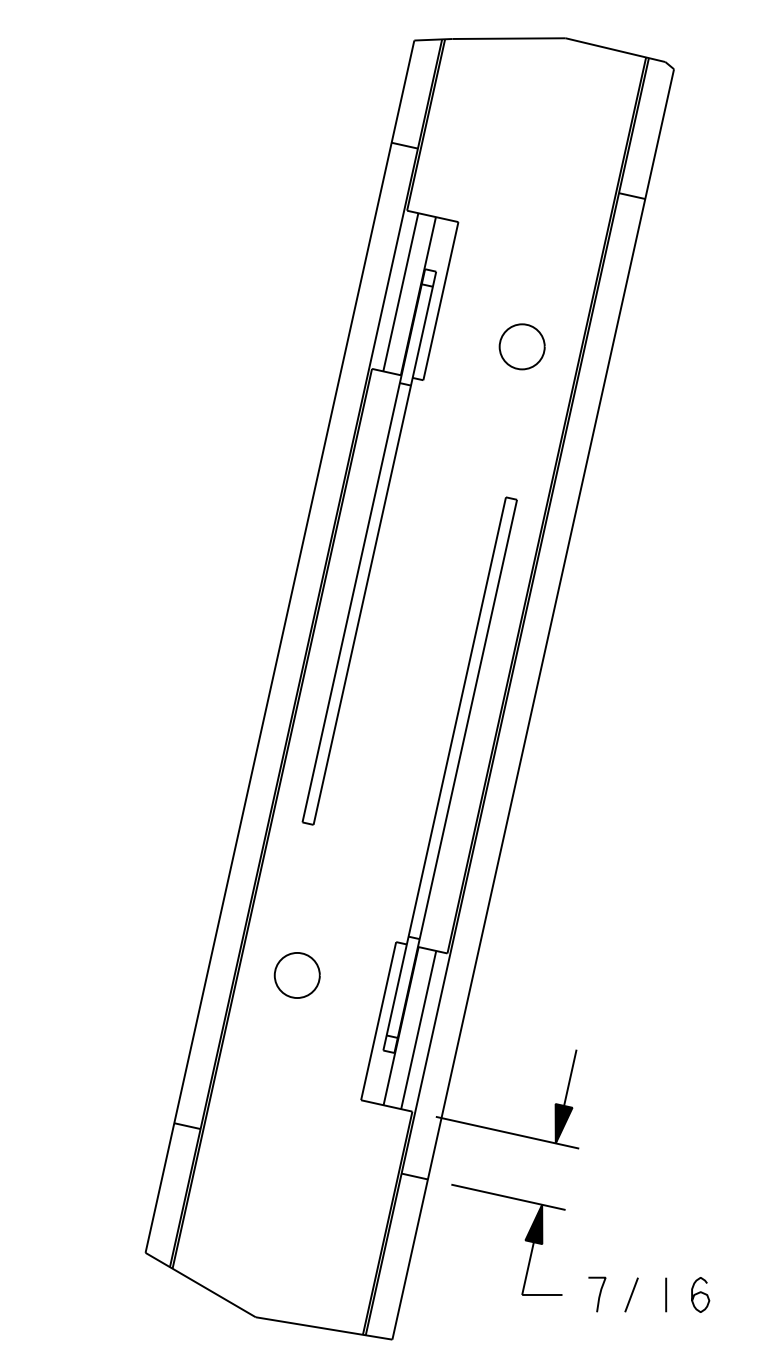
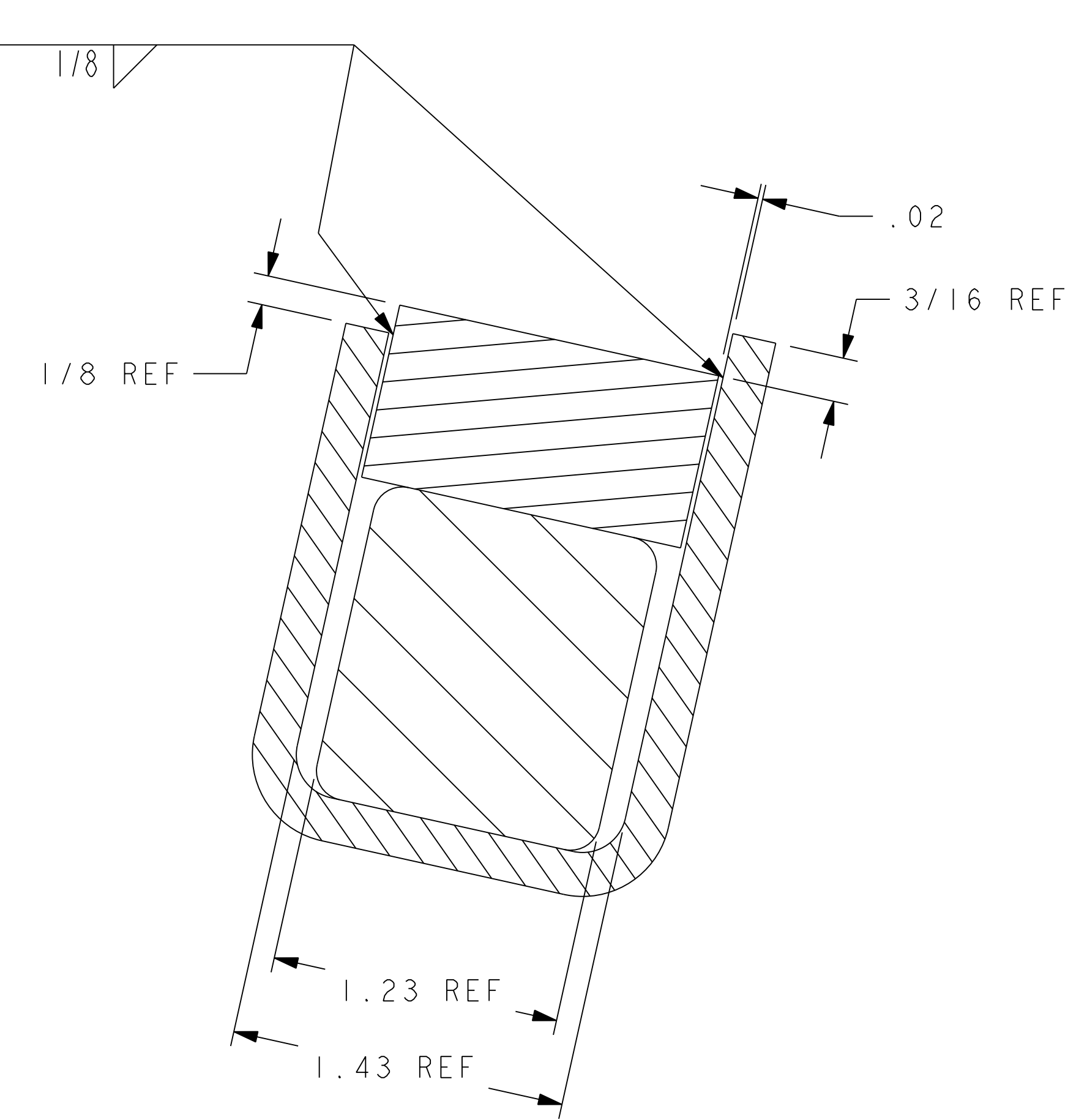

DETAIL A
SCALE 0.75

SECTION A - A
SCALE 2

- NOTES:
1. WELDING SHALL BE PERFORMED IN ACCORDANCE WITH THE REQUIREMENTS OF AWS D1.1 OR PPL PPPL PROCEDURE ENG-037. VISUAL WELD INSPECTION SHALL BE PERFORMED IN ACCORDANCE WITH THE ACCEPTANCE CRITERIA OF AWS D1.1 Section 6.
 2. VENDOR TO CERTIFY THAT STOCK MATERIAL EXHIBITED MAGNETIC PERMEABILITY OF LESS THAN 1.02 Mu.
 3. IF AFTER WORKING OR MACHINING PART HAS MAGNETIC PERMEABILITY GREATER THAN 1.02 Mu, THEN PART IS TO BE VACUUM HEAT TREATED AT 1100°C FOR 2.5 HRS TO BRING THE MAGNETIC PERMEABILITY BELOW 1.02 Mu.
 4. SPECIAL PROCESS WITH HEAT SINK REQUIRED TO GAURENTEE COIL TEMPERATURE DOES NOT EXCEED 100°C FURTHER WELDING PROCESS DEVELOPMENT IS REQUIRED.

PART NO.	DRAWING NO	NOMENCLATURE OR DESCRIPTION	MATERIAL	QTY	RECD
7	SE133-034-3B	CHANNEL SUPPORT CAP #3	316 SS/STL	1	
6	SE133-034-3A	CHANNEL SUPPORT CAP #3	316 SS/STL	1	
5	SE133-034-2A	CHANNEL SUPPORT CAP #2	316 SS/STL	1	
4	SE133-034-1C	CHANNEL SUPPORT CAP #1	316 SS/STL	1	
3	SE133-034-1B	CHANNEL SUPPORT CAP #1	316 SS/STL	1	
2	SE133-031	TRIM COIL #1 GROUND-WRAPPED ASSEMBLY	COPPER/EPOXY	1	
1	SE133-064-1	TRIM COIL BASE SUPPORT	316 SS/STL	1	

COMPUTER GENERATED DRAWING MANUAL CHANGES NOT PERMITTED Pro E		CENTRAL FILES:	PRINCETON PLASMA PHYSICS LABORATORY NATIONAL COMPACT STELLARATOR EXPERIMENT	
DO NOT VERIFY INFORMATION BY SCALING DRAWING		UNLESS OTHERWISE SPECIFIED DIMENSIONS ARE IN INCHES MACHINE SURFACES BREAK SHARP EDGES .005/0.020	STELLARATOR CORE TRIM COILS TRIM COIL #2 WELDMENT	
WEIGHT 124.4 lbs		TOLERANCES NON-CUMULATIVE	DSN: R. UPCAUGE	6/10/08
MODEL NAME SE133-064-01		DECIMAL-INCH FRACTIONS	CHK: M. KALISH	6/10/08
WELDING ENGINEER		.XX ±.000 .XXX ±.005 ANGULAR ±.0°-15°	ENGR: M. KALISH	6/10/08
RELEASE LEVEL: Fabrication DWG VERSION NO: 25		OVER 120° ±.12°	SUPV: J. SIEGEL	6/10/08
			DRAWING NO: SE133-064	SHEET 1 OF 1
			REV 0	

NCSX-SE133-064

NCSX-ASSY-FORMAT.E