

# Princeton Plasma Physics Laboratory Procedure

**Procedure Title: Field Period Assembly Station One**

Number:  
**D-NCSX-FPA-001**

Revision:  
**3**

Effective Date: **11/5/2007**

Expiration Date:  
(2 yrs. unless otherwise stipulated)

## Procedure Approvals

Author: John W. Edwards:

ATI: Mike Viola:

RLM: Larry Dudek:

Responsible Division: NCSX Project

## Procedure Requirements Designated by RLM LAB-WIDE:

<b>X</b>	Work Planning Form (ENG-032) #1224		Lockout/Tagout (ESH-016)
	Confined Space Permit (5008, SEC.8 Chap 5)		Lift Procedure (ENG-021)
	Master Equipment List Mod (GEN-005)	<b>X</b>	ES&H Review (NEPA, IH, etc.) NEPA 1283
	RWP (HP-OP-20)		Independent Review
	ATI Walkdown	<b>X</b>	Pre-Job Brief
<b>X</b>	Post-job Brief *	<b>X</b>	Hydrostatic and Pneumatic Testing. (ENG-014)

## D-SITE SPECIFIC:

<b>X</b>	D-Site Work Permit (OP-AD-09)		Door Permit (OP-G-93)
	Tritium Work Permit (OP-AD-49)		USQD (OP-AD-63)
<b>X</b>	Pre-Job Brief (OP-AD-79)		T-Mod (OP-AD-03)
	**DCA/DCN (OP-AD-104) #		

\* Required for installations involving internal vacuum installations, critical lifts, and for the initial installation of repetitive work.

\*\* OP-AD-104 was voided by procedure ENG-032. However, DCA's that were open at the time of adoption of ENG-032 are still considered valid for work approval purposes.

## REVIEWERS (designated by RLM)

	Incorporated Comments
Accountable Technical Individual..... <b>Mike Viola</b>	
Test Director	
Independent Reviewer	
D-Site Shift Supervisor..... <b>John Edwards</b>	
Independent	
NCSX Dimensional Control Coordinator..... <b>s</b>	
Vacuum Vessel Cognizant Engineer.....	
NCSX Field Supervisors..... <b>Steve Raftopoulos, Mike Viola</b>	
Project Engineer for Stellarator Systems (WBS 1) Manager.....	
FPA Tooling and Constructability .....	
Quality Assurance/Quality Control..... <b>Frank Malinowski/Colin Phelps</b>	
<b>Maintenance and Operations Division</b>	
Energy Conversion System/Motor Control Division	
Engineering .....	<b>Phil Heitzenroeder</b>
<b>Environmental Restoration &amp; Waste Management Division</b>	
Environmental, Safety & Health.....	<b>Jerry Levine</b>
Industrial Hygiene.....	<b>Bill Slavin</b>
Health Physics.....	<b>George Ascione</b>
RLM.....	<b>Larry Dudek</b>

## TRAINING (designated by RLM)

No training required _____ Instructor <b>John Edwards</b>			
Personnel (group, job title or individual name)	Read Only	Instruction Pre-job Briefing	Hands On
Lead Tech.		X	
Technicians performing task		X	
Field Supervisors		X	
Quality Control Representative		X	
Training Rep.			
RLM <b>Larry Dudek</b>			

**Field Period Assembly Station One  
D-NCSX-FPA-001**

**RECORD OF CHANGE**

<b>Revision</b>	<b>Date</b>	<b>Description of Change</b>
00	6/15/2006	Initial release
01	12/04/2006	Updated to Revise Sections 6.8.7.1 and 6.12.2 to relax electrical isolation requirements to 600 volts with readings of greater than >10 MOhms as per NCR 3715.
02	10/8/2007	Updated to: <ul style="list-style-type: none"> <li>• Reflect re-ordering and addition of Tables at end of procedure and to provide links to tables and figures.</li> <li>• Modify Section 6.12.2 to also specify temperature range requirement.</li> <li>• Remove “TBD” in Sections 6.13.4, and 6.13.7 and replaced with 65 in-lbs.</li> <li>• Modify Sections 6 and 6.6.2 to clarify that additional information deemed useful for future reference may be appended as desired.</li> <li>• Modify Sections 6.1.6 and 6.2.5 to clarify that the Lead Technician shall record, date, and initial significant changes or events in the Station Log Book..</li> <li>• Modify Section 6.11.1 to clarify that Cognizant Engineer should be contacted to identify which holes through the CF flange and Jb are to be used for cables and on which drawing this detail is shown.</li> </ul>
03	11/5/2007	Corrected Sections 6.8.7.1 and 6.12.2 to reflect heat tape and thermocouple isolation requirements as per NCRs 3715 & 3719.

Field Period Assembly Station One  
D-NCSX-FPA-001

## TABLE OF CONTENTS

1.	Scope.....	1
1.1	Introduction.....	1
1.2	Scope.....	1
1.3	Identification of Vacuum Vessel Segment being assembled: .....	1
2.	Applicable Documents: .....	1
2.1	NCSX-MIT/QA-185-00:.....	1
2.2	NCSX-PLAN-MFOP-01:.....	1
2.3	D-L-NCSX-007 Lifting Vacuum Vessel Segment.....	1
2.4	D-NCSX-PLAN-FPA1DC-00 VV Dimensional Control Plan .....	1
2.5	NCSX-CSPEC-185-01 Product Specification Station 1 Field Period Assembly .....	1
3.	Safety Requirements: .....	1
3.1	Job Hazard Analysis: .....	1
4.	Prerequisites & Conditions:.....	2
4.1	Pre-Job Briefing:.....	2
4.2	Daily Operations Startup and Shutdown:.....	2
5.	Materials and Parts for this station.....	2
6.	Assembly Process.....	2
6.1	Daily Startup Activities:.....	3
6.2	Daily Shutdown Activities: .....	3
6.3	Replace Port Flanges with Station 1 Assembly Flanges: .....	3
6.4	Install VVSA in Station One Rotating Fixture:.....	4
6.5	Metrology Set-up and Initial Vessel Measurements .....	5
6.6	Marking Flux Loop Template:.....	7
6.7	Marking Heating Coolant Stud Locations: .....	9
6.8	Vertical Port Component Installation .....	10
6.10	Installing of Magnetic Flux Loop .....	12
6.11	Final Loop Routing and Measurement.....	14
6.12	Thermocouple installation.....	15
6.13	Installation of H/C lines .....	15
7.	Completion of Activities at Station One: .....	18
7.1	Document Verification:.....	18
7.2	Field Package:.....	18
7.3	Approval:.....	18
7.4	Preparing and Transferring Completed VV to Holding Area.....	18
Appendix A. Document Sign Off.....		20
1.3	Vacuum Vessel Segment Identification .....	20
4.1	Pre Job Briefing: .....	20
6.4.7	Rotating fixture secure:.....	20
6.4.8	Cg verification: .....	20
6.5.1	Arrows marked for toroidal field direction:.....	20
6.5.4	Best fit to Fiducials: .....	20
6.7.2	Heating/cooling studs: .....	21
6.8.3	Cryostat Interface Flange: .....	21

**Field Period Assembly Station One  
D-NCSX-FPA-001**

6.8.4 Heating/cooling header bracket.....	21
6.8.5 Thermocouple mounting plates:.....	21
6.8.6 Heating/cooling support brackets.....	21
6.8.7 Heating strips.....	22
6.8.7.1 Heating strips continuity and isolation test.....	22
6.10.6 Loop Templates best fit to Model:.....	22
6.10.8 Loop Continuity and resistance check:.....	22
6.11.4 Final Loop Measurements:.....	23
6.13.3 Heating/cooling manifold.....	23
6.13.4 Heating/cooling tube stud torque:.....	23
6.13.5 Heating cooling hard tubing:.....	23
6.13.7 Heating/cooling tube stud re-torque: .....	24
7.3 Approval:.....	24

**Index of Figures**

Figure 1 Horizontal Flange.....	3
Figure 2 Heating and Cooling Cryostat Interface Flanges .....	4
Figure 3 Vacuum Vessel in Horizontal Position .....	5
Figure 4 Worm Drive Installation Details .....	5
Figure 5 Arrow Mark Toroidal Field Direction .....	6
Figure 6 60 degree off Vertical Position.....	7
Figure 7 Vacuum Vessel in Rotated Position .....	7
Figure 8 Template Locating and Numbering .....	8
Figure 9 Overlays of the Coolant Lines over the Diagnostic Loops.....	9
Figure 10 Cryostat Interface .....	10
Figure 11 Heating strip.....	11
Figure 12 Installing Loop Templates.....	12
Figure 13 H/C Support Brackets .....	15
Figure 14 Hard Tube Installations .....	16
Figure 15 NB Angle Support Bracket and Base Support Plate .....	19
Figure 16 Stage 3 Support Stand.....	19

**Index of Tables**

Table 1-Loop Installation Data for Field Period 1.....	25
Table 2 Loop Installation Data for Field Period 2.....	28
Table 3 Loop Installation Data For Field Period 3.....	31
Table 4 Loop Placement Data for Field Period - Sheet 1.....	34
Table 5 - Loop Placement Data for Field Period 2 –Sheet 1 .....	40
Table 6 - Loop Placement Data for Field Period 3 – Sheet 1 .....	46
Table 7 - Stud Installation Data .....	52
Table 8 - Table H/C/ Lines Installation and Leak Check Data .....	89

**Field Period Assembly Station One  
D-NCSX-FPA-001**

**Table 8 - Table H/C/ Lines Installation and Leak Check Data (continued) .. 92**

# Field Period Assembly Station One

## D-NCSX-FPA-001

### 1. Scope

#### 1.1 Introduction

The Field Period Assembly is divided into 5 workstations. Each workstation has a specific set of tasks that will be performed as part of the overall assembly process. This procedure addresses the manufacturing, inspection, test and QC inspection points for a specific workstation.

Station No. 1 Vacuum Vessel Subassembly (VVSA) Activities

#### 1.2 Scope

This procedure is used to describe the assembly sequence required for Station 1 Field Period Assembly.

Installing the Vacuum Vessel in the turning fixture

Metrology measurements

Flux Loop Locations

Heating Cooling Tube Stud Location

Installation of Flux Loops

Installation of Heating –Cooling Tubes

#### 1.3 Identification of Vacuum Vessel Segment being assembled:

Lead Technician See Appendix A – Document Sigh-off-Record
---

### 2. Applicable Documents:

#### 2.1 NCSX-MIT/QA-185-00:

All applicable documents associated with this procedure, are identified in the MIT/QA Plan, document number **NCSX-MIT/QA-185-00**.

#### 2.2 NCSX-PLAN-MFOP-01:

All work processes are governed by the latest version of “NCSX Manufacturing Facility Operations Plan”, document number **NCSX-PLAN-MFOP-01**.

#### 2.3 D-L-NCSX-007 Lifting Vacuum Vessel Segment

#### 2.4 D-NCSX-PLAN-FPA1DC-00 VV Dimensional Control Plan

#### 2.5 NCSX-CSPEC-185-01 Product Specification Station 1 Field Period Assembly

#### 2.6 NCSX-CSPEC-31-01 Diagnostic Specification External Saddle Loops

### 3. Safety Requirements:

All work will be performed in a safe manner in accordance with PPPL Environmental Safety & Health Directives **ES&H 5008** and the “Integrated Safety Management” (ISM) policy.

#### 3.1 Job Hazard Analysis:

A JHA will be generated for each Vacuum Vessel Sub Assembly station, identifying existing or potential workplace hazards and to evaluate the risk of worker injury or illness associated with job tasks. (Reference document **ESH-004 “Job Hazard Analysis”**) The IH representative will review the JHAs for accuracy as well as completeness. It will be reviewed with all activity participants at the Pre-Job briefings.

**Field Period Assembly Station One  
D-NCSX-FPA-001**

**4. Prerequisites & Conditions:**

**4.1 Pre-Job Briefing:**

A pre-job briefing will be held, describing the processes and safety issues prior to starting any part of this procedure. Attendance shall be documented via training sign-in sheet.

**VV Field Supervisor See Appendix A – Document Sign-off Record**

**4.2 Daily Operations Startup and Shutdown:**

Each working day the Lead Technician it is required to complete and initial the daily operations startup log to ensure that the station is ready to commence work activities for the day. The signoff log is located in the Daily Station Log. See section 6.1 and 6.2 for details.

**5. Materials and Parts for this station**

The following materials and/or equipment will be used with this procedure.

<b>General Description</b>	<b>Material</b>	<b>Reference Document/Product No.</b>
Vacuum Vessel Sub Assembly	See Drawing	SE120-002
VVSA Support Stand Assembly	See Drawing	SE184-001
Magnetic Diagnostic Templates	Copper	SE310-030-A-Q,Se310-030-THO SE310-030-THO-TH180
Vacuum Vessel Heating/Cooling Assembly	See Drawing	SE121-008,SE121-009
Thermocouple Mounting	See Drawing	SE121-004
Header Standoff	See Drawing	SE121-009

**6. Assembly Process**

This assembly procedure is to be used as guide to complete the station no. 1 activities. Deviation from this procedure for processes that DO NOT affect the design of the assembly can be made during the assembly process with the concurrence of the VVSA Field Supervisor. All deviations shall be documented in the procedure and initialed by the VVSA Field Supervisor prior to implementing the deviations. Deviations that may affect the design of the assembly requires a Request for Deviation "RFD" approval. The RFD must be approved prior to proceeding. Procedure changes need to be incorporated into the document via "Minor Procedure Changes" or "Revisions". Additional information deemed useful for future reference may be appended as desired.



## Field Period Assembly Station One D-NCSX-FPA-001

### 6.1 Daily Startup Activities:

- 6.1.1 Verify operation of all equipment needed that day.
- 6.1.3 Check that safety equipment needed for day's activities are available
- 6.1.5 Check that the day's travelers (I.E. Appendix A) and procedures are in their document holder.
- 6.1.6 Lead Technician shall record, date, and initial significant changes or events in the Station Log Book.

### 6.2 Daily Shutdown Activities:

- 6.2.1 Turn off power to equipment not in use.
- 6.2.2 Lock Cabinets.
- 6.2.3 Verify that all Traveler (i.e., Appendix A) and data sheet information is complete.
- 6.2.4 Verify that all deviation from the procedure have been documented in the procedure and initialed by the VVSA Field Supervisor.
- 6.2.5 Lead Technician shall record, date, and initial significant changes or events in the Station Log Book..

### 6.3 Replace Port Flanges with Station 1 Assembly Flanges:

- 6.3.1 If attached remove the two horizontal port flanges covers and bag bolt assemblies for future use. See Figure 1.

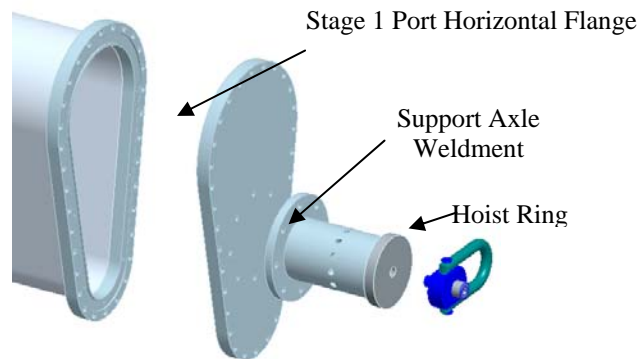
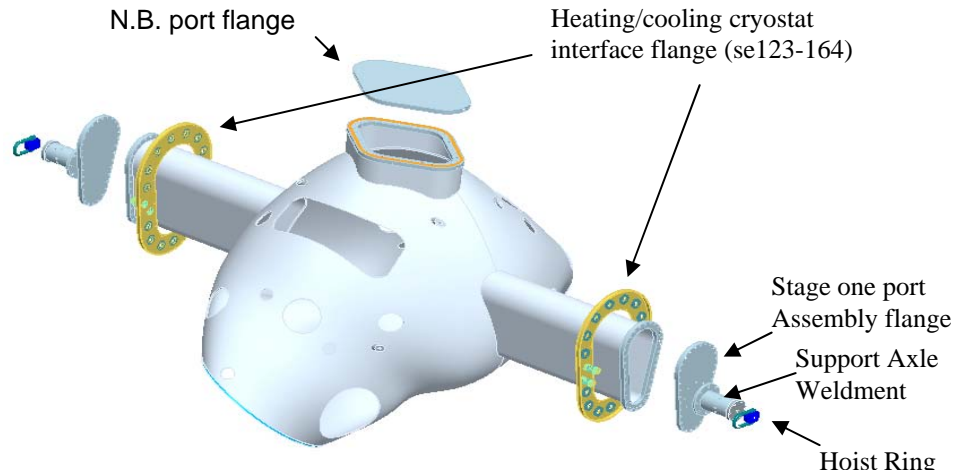

**Figure 1 Horizontal Flange**

- 6.3.2 If attached remove NB port flange cover and bag bolt assemblies for future use. Install temporary port cover se 184-054 and seal spacer se 184-055. See Figure 2.

## Field Period Assembly Station One D-NCSX-FPA-001

- 6.3.3 Install VV heating/cooling cryostat interface flanges by slipping each over each vertical port. The interface flanges need to be temporarily supported on the flanges. Reference drawing: se123-164. See Figure 2.



**Figure 2 Heating and Cooling Cryostat Interface Flanges**

- 6.3.6 Using rubber gasket material or gortex gasket material on the flanges for flange protection install stage one port assembly flange covers. Torque flange bolts to 50 foot lbs.
- 6.3.7 Using shim stock as needed to keep support axle weldment coaxial. Install support axle weldment to stage one port assembly flanges.
- 6.4 Install VVSA in Station One Rotating Fixture:**
- 6.4.1 Using lift procedure (D-L-NCSX-997) and test cell crane, basket around the two VVSA port 12's. Lift VVSA enough to remove load from a base support then remove support base by grinding the welds off the support base to VVSA. Lifts VVSA high enough too allow the VVSA base support to be removed from under the VVSA.
- 6.4.2 Lubricate support axle and axle support cradle. Add lubricant to support axle weldment and support axle cradle components (cradle top and cradle base) to reduce VV rotation friction.
- 6.4.3 Mount VV on Station one rotating fixture in the horizontal position. See Figure 3.

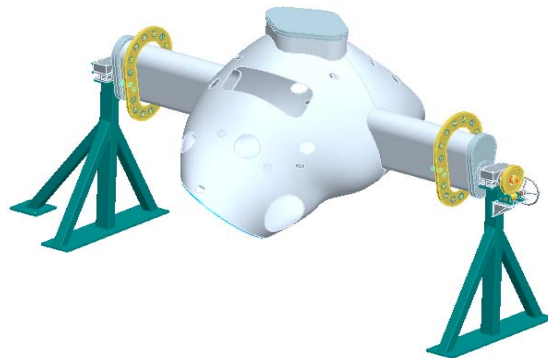

**Field Period Assembly Station One  
D-NCSX-FPA-001**

**Figure 3 Vacuum Vessel in Horizontal Position**

- 6.4.4 Secure in place by bolting down support axle cradle to support blocks. See Figure 4.
- 6.4.5 Install quick release pin. See Figure 4.
- 6.4.6 Install worm gear axle and worm gear. See Figure 4.

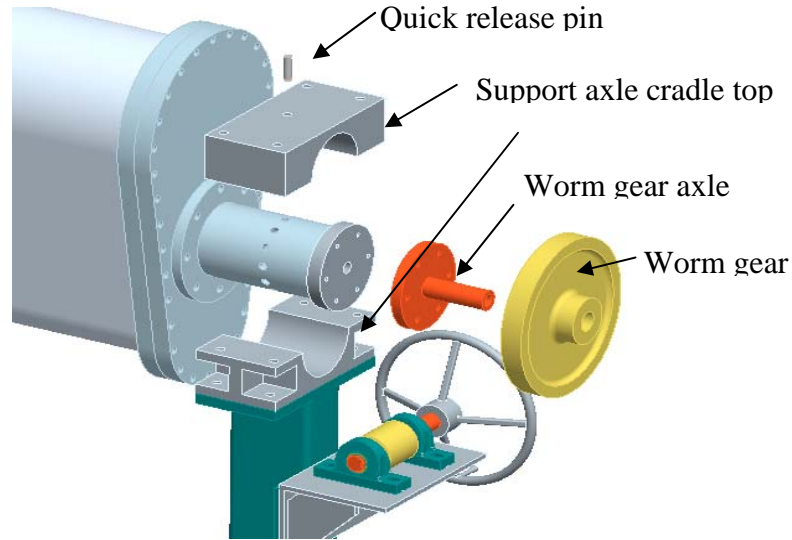

**Figure 4 Worm Drive Installation Details**

- 6.4.7 Verify all components of rotating fixture are secure and that VV is ready to rotate.

**Lead Technician See Appendix A – Document Sign-off Record**

- 6.4.8 Using rotating crank handle and ratchet mechanism slowly rotate VV on its horizontal axis checking to see that the center of gravity (CG) is correct and not putting undue strain on the rotating mechanism.

**Note:** If VV CG is found to be off enough to cause rotating problem the support axle weldments will have to be moved or weight added to VV to shift the CG.

**Lead Technician See Appendix A – Document Sign-off Record**

**6.5 Metrology Set-up and Initial Vessel Measurements**

- 6.5.1 Using a marker mark the positive toroidal field direction (SF-110-030-1 sheet 3) on the front and back surface of the vacuum vessel.

**Note:** The worm gear system is identified as the VV down direction. See Figure 5.

Field Period Assembly Station One  
D-NCSX-FPA-001

Lead Technician See Appendix A – Document Sign-off Record

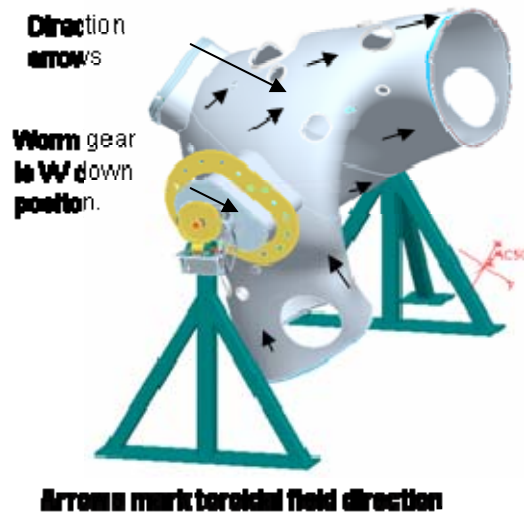

Figure 5 Arrow Mark Toroidal Field Direction

- 6.5.2 Rotate the VVSA through one full revolution and take note of the MTM supplied fiducial points. Determine whether the MTM supplied fiducials are adequate in number and location to allow alignment to the VVSA from any desired rotation on the turning fixture. Add additional fiducial points if required.

**Note:** Some monuments will be located on the body of the VVSA

- 6.5.3 Perform a best fit to the fiducial measurements using the monuments on the VV body. Settings will be made with the vessel NBI port at a  $\pm 60^\circ$  off vertical position as indicated in Figure 6 and Figure 7. Secure vessel position by inserting release pin and tighten support axle cradle bolts. Verify that the mounting system is rigid enough to meet FP Dimensional Control Plan metrology requirements.

## Field Period Assembly Station One D-NCSX-FPA-001

6.5.4 If additional fiducial points were added in step 6.5.2, measure their location.

**Metrology Technician and Engineer See Appendix A – Document Sign-off Record**

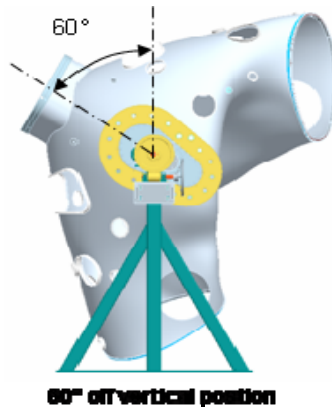

**Figure 6 60 degree off Vertical Position**

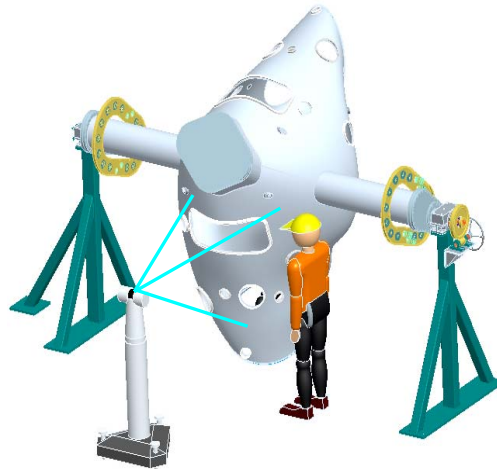

**Figure 7 Vacuum Vessel in Rotated Position**

### 6.6 Marking Flux Loop Template:

Each loop template has four locating notches which shall be used to install loops within  $\pm 0.160$ " of marked locations, except for the loops at the symmetry points which shall be positioned within  $\pm 0.020$ ". **Each template position is defined by its multiple locator points (ideal) listed in the table of drawings #se310-030-1 to 3).** Using a sharpie permanent marker transfer the locator points for all copper templates to the measurement **Veri Surf** software. These points are the centers of the 0.020 inch radius semicircles machined on each side of a template. These are the ideal locations as defined in the CAD model. There will be some variation of the vessel surface from the CAD model and therefore the locator points. Installation will therefore be on a best fit basis recommended by the personnel responsible for the installation including metrology. Document relocated template location points.

## Field Period Assembly Station One D-NCSX-FPA-001

**Minimize the distance between an ideal point and a final selected surface point, while keeping the difference in the local x-y coordinates to less than 0.160 inch for the general loops and 0.020 inch for the symmetry loops. A secondary requirement for a Field Period symmetry loop is that it be equidistant from the center of the NB port (theta = 0) and the corresponding point at the inner center (theta = 180) with a local x-y coordinate difference of less than 0.020 inch, if the as built dimensions of the vacuum vessel do not permit the first requirement to be met.**

**\*Note: That there are 2 similar symmetry loops on each field period spacer with similar requirements. The total number of symmetry loops is 12. Six on the FP's and six on the FP spacers.**

When locating the templates, some of the fiducial points may be located such that they interfere with the template positioning. Individual fiducial points may be removed (and relocated if necessary), as long as there are sufficient additional fiducial points in the vicinity to allow for alignment and measurement of the relocated point

- 6.6.1 Secure vessel position with the 60° NBI port at a +/- 60° off vertical position by inserting release pin and tighten support axle cradle bolts.
- 6.6.2 Mark surface with permanent marker for all loop placements with the vessel NBI port at a +/- 60° off vertical position. It is expected that three metrology positions will be required on each side to accurately mark the vessel. The metrology system will be used to accurately define four marks (within +/-0.160") for each of the 55 loops except for the loops at the symmetry points which shall be positioned within +/-0.020". The magnetic loop locating points are to be permanently marked on the vessel in a way that does not distort the surface. As each set of locator points are marked, outline the rough geometry of the template, and circle the locator points. For ease of locating templates mark template number at center of four points. See **Figure 8** below and Reference drawing see 310-030-1 to 3 for loop designation, point marking details and model geometry data.

**NOTE: All Loop installation data to be logged on Table 1, Table 2 or Table 3 at end of procedure. Additional information deemed useful for future reference may be appended as desired.**

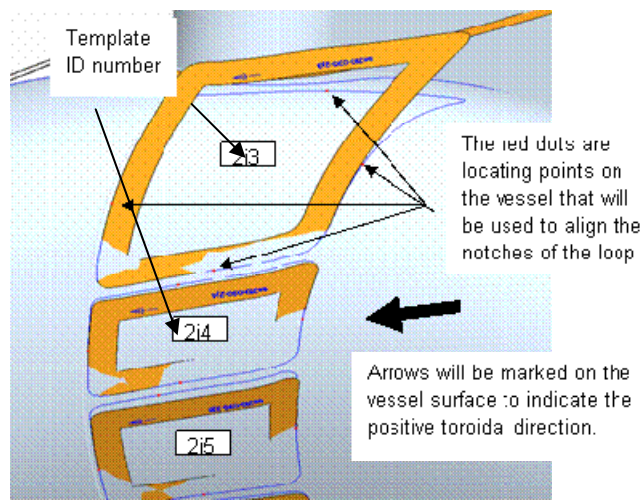

**Figure 8 Template Locating and Numbering**

**Field Period Assembly Station One  
D-NCSX-FPA-001**

**6.7 Marking Heating Coolant Stud Locations:**

6.7.1. The Leica or Roma Arm metrology system will be used to locate **730** studs per half period at 5" spacing. Fine accuracy is not important **spacing may be varied along the length of the theoretical hose location +/- 1 inch and lateral +/- 1/2 inch if necessary to avoid interference with flux loop installation.** The stud location shall be marked with a circle with a name designation added ( A1, A2, A3.) to define the series. An outline of the coolant line and hold-down bracket shall also be marked. See **Figure 9** and reference drawing se121-008 sheet 4 for cooling loop designation and locator point details.

**NOTE: All stud location data to be logged on Table 7 at end of procedure. Additional information deemed useful for future reference may be appended as desired.**

6.7.2 Install all heating / cooling tube weld studs that do not interfere with flux loop templates. Use heating cooling tube saddle foot print as a guide to maintain a minimum distance of 1/4 inch from the flux loops. Remaining heating / cooling tube weld studs will be installed after flux loops are installed. **Caution: Use heat blanket, taps on foil to protect flux loops from weld slag during installation of remaining studs.**

**Lead Technician and QC Representative See Appendix A – Document Sign-off Record**

**NOTE:**

The cooling lines overlay the diagnostic loops.

1. Use Reference drawing: se 123 008 and Dimensional Control Plan: NCSX-PLAN-FPA1DC-00.
2. Location of H/C tube mounting hardware in reference to Flux Loops must be considered before studs are welded on VVSA.
3. All H/C installation data to be logged on Table 8 at end of procedure

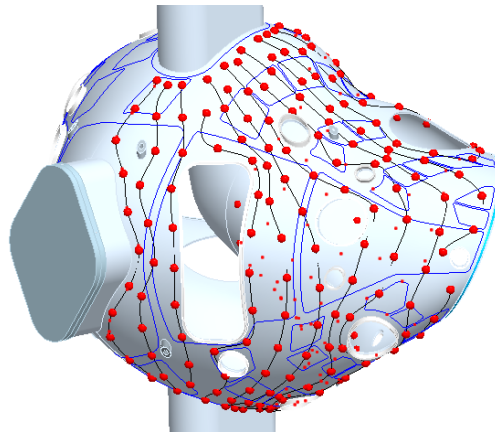
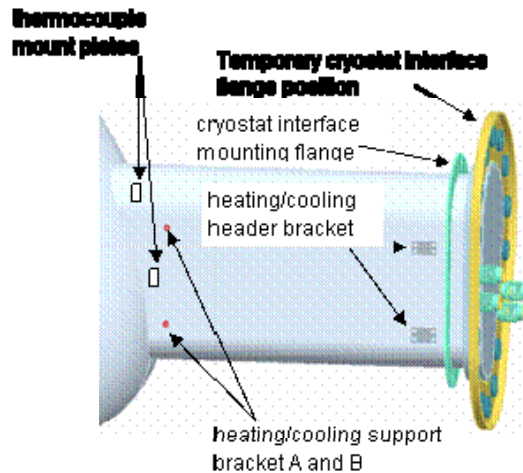

**Figure 9 Overlays of the Coolant Lines over the Diagnostic Loops**

**Field Period Assembly Station One  
D-NCSX-FPA-001**

**6.8 Vertical Port Component Installation**

- 6.8.1 Mark heating/cooling support bracket A and B attachment studs and mark bracket clip outline. **See Figure 10 and SE121-008.**
- 6.8.2 Install cryostat interface mounting flange on vertical ports. Before welding the interface flange on the vertical ports the cryostat interface flange must be moved into the proper assembly position. **See Figure 10 and SE121-049.**



**Figure 10 Cryostat Interface**

- 6.8.3 Install cryostat interface flange on vertical ports. **See Figure 10 and SE121-049**

**Lead Technician and QC Representative See Appendix A – Document Sign-off Record**

- 6.8.4 Install heating/cooling header bracket. **See Figure 10 and SE121-008**

**Lead Technician and QC Representative See Appendix A – Document Sign-off Record**

- 6.8.5 Install 29 thermocouple mounting plates on port 12's and vacuum vessel. **See Figure 10 and SE121-004**

**Lead Technician and QC Representative See Appendix A – Document Sign-off Record**

- 6.8.6 Install heating/cooling support bracket studs. **See Figure 10 and SE121-004**

**Lead Technician and QC Representative See Appendix A – Document Sign-off Record**

- 6.8.7 Install heating strips on vessel vertical ports. **See Figure 11 and SE121-004**

**Lead Technician and QC Representative See Appendix A – Document Sign-off Record**



**Field Period Assembly Station One  
D-NCSX-FPA-001**

- 6.8.7.1 Perform electrical continuity check and an electrical isolation test on the heater strips as per NCSX-PRL-12-002-02 (The over wrap insulation shall be of a braided fabric construction capable of >10.0 MOhms at a minimum of 600V.).

**Lead Technician and QC Representative See Appendix A – Document Sign-off Record**

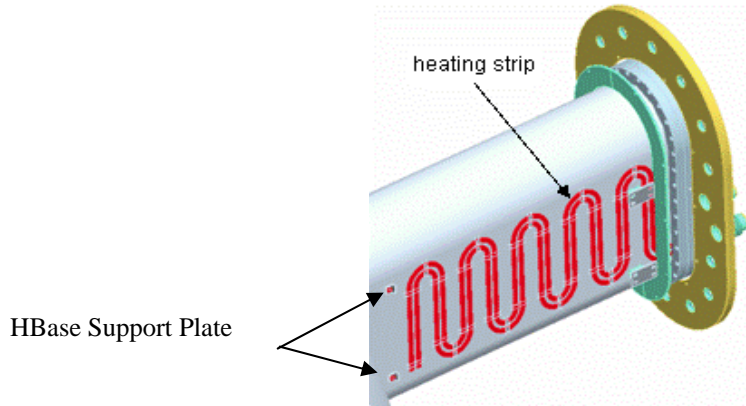

**Figure 11 Heating strip**

- 6.8.8 Mark vessel surface showing voltage loop paths.
- 6.8.9 Mark vessel surface showing flux loop twisted pair leads path.

### **6.9 Installing of Magnetic Flux Loop Templates**

- 6.9.1 Rotate VVSA to convenient installation position for locating loop templates. Each loop template has four locating notches which shall be used to install loops. Locate the template, **contour the template to the vessel surface by hand**, and fix it to the vessel using flat 316 SS shim stock clips (0.010 recommended, strong enough to hold the template yet developing a weak enough spot weld that can be easily removed with a chisel). Initially use only enough clips to support the template but allow it to be moved if need be. Using the metrology system verify the position of template and add additional clips securing the template at this position. If the tolerance deviation of the vessel does not allow the tolerance achievement of the loops then the cognizant physicist will determine the acceptable position. Installation will therefore be on a best fit basis to be approved by the physics and engineering cognizant and recommended by the personnel responsible for the installation including metrology. Templates Th180-1 thru Th180-5 need to be placed and the flux loop wires run before adjacent loops are placed because of local template interferences. See **Figure 8**. After symmetry loop Templates Th180-1 thru T h180-5 are secured and positions verified use a sharpie permanent marker to mark the path of the voltage loops on the vessel period surface. Proceed to step 6.10 and install flux loop wires for the five symmetry Loops.
- 6.9.2 Install **Templates Th180-1 thru Th180-5** on the field period and log all information for each template on table 1 at end of procedure. After loop Templates Th180-1 thru T h180-5 are secured and positions verified, mark the path of the loops on the vessel period surface. Precede to step 6.11 and install flux loop wires for the five Loops.

**Note: The locating direction arrow should be aligned in the general direction of the positive toroidal field direction arrows marked on the vessel surface. See Figure 12.**

**Field Period Assembly Station One  
D-NCSX-FPA-001**

**Note: Log installation data in Table 1, Table 2, or Table 3.**

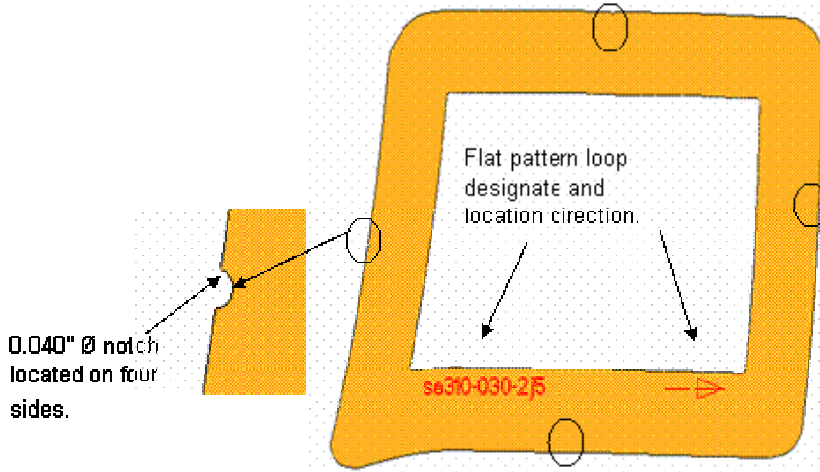

**Figure 12 Installing Loop Templates**

**6.10 Installing of Magnetic Flux Loop**

6.10.1 Each saddle Loop consists of a two turn coil of an Inconel sheath and conductor, coaxial cable and twisted leads which run along the vessel surface and exit the cryostat region thru a 2.75 inch CF in the horse collar of a vertical port. The cables will be terminated in a junction box at a later time. Up to 20 twisted pairs will enter a JB.

Determine the unique length of co axial cable required for a complete loop including the twisted pair. Use a pliable yet non stretching material (stranded wire) to determine the circumference of the template and the developed length needed for the twisted pair along the marked path and along the vertical port and to the JB. The circumferential length is determined by measuring the template perimeter (P) and multiplying by 2 (two turn coil). The twisted pair length (lg) is determined by measuring the path marked on the vessel surface up to and into the JB, adding 18 inches and multiplying by 2.8. The total minimum length of coaxial cable needed to form a two turn loop and a twisted pair into the JB, with sufficient length to strain relieve the cable and terminate them into the terminal blocks is  $L = 2(P) + 2.8(lg+18)$ .

At a few locations where the twisted pair crosses a Voltage Loop the pitch will be interrupted and the pair will be run straight and parallel and touching for up to 2 inches. The voltage loop (single coaxial cable) will cross over the twisted pair at this location. This straight length pair will have a hold down clip on each side of the Voltage Loop and the flux Loop will have a hold down clip on either side of the twisted pair.

**Note: An acceptable after note is in the voltage loop to cross over the twisted pair if these is no local interference with H/C tubes.**

**Field Period Assembly Station One**  
**D-NCSX-FPA-001**

- 6.10.2 After the Loop length is determined cut the length from the large roll and remove all kinks and twists.

Seal both ends and the end on the large roll with the moisture barrier material provided. The MGO insulator is hygroscopic and must be sealed from moist air immediately after being cut.

½ inch wide by 3/8 inch deep indents have been provided along the edge of each template to accommodate the use of shim stock as hold downs. The hold downs are preformed and are 0.005 inch thick 316 SS. The clips are to have a magnetic permeability of less than 1.02. QA is to check a random sampling of 50 clips. High magnetic permeability can be mitigated by heat treating. There is sufficient space in an indent to accommodate 2 hold down clips. The partial clips are to be used to secure the inner turn and the full clips secure the outer turn. The copper templates are 0.043 inch thick and have the central portion removed to facilitate conforming to the vessel surface and allow for the placement of the template holding clips. Use at least 4 spot welds to weld the clip to the vessel surface. Check each clip and ensure that the spot welds have punched through and the clip is secure.

- 6.10.3 The best point on the template to start the twisted pair was determined before the loop length was calculated therefore keeping this in mind start the wrap of the inner turn around the template and install a pre formed 0.005 inch thick SS partial clamp at each indent by spot welding, leaving sufficient space for the full clamp to be installed adjacent to it. In general the lower limit for the bend radius is ¼ inch. Minimize the dead space or excess area formed at the point where the inner and outer turns meet to start the twisted pair. Determine a method to form the same dead or excess area for all loops. This area will be added to the loop measurement area.

- 6.10.4 A simple plastic tool with two parallel holes drilled through has been developed to assist in the task of forming the twisted pairs. ***The polarity sense is to be maintained (clockwise looking at the template) if practical. If a counter clockwise polarity loop must be installed, document the loop tag number under comments in table 3. Twist the leads up to but not into or beyond, the entrance of the JB. The cable is to be smooth and leads parallel through the JB rubber seal. The twisted leads are to be identified with a 2 digit color band using the color code of drawing se310-0301 to 3.*** There are less than 100 loops on the highest density field period. The twisted pair is to be identified in more than one location along its path and in the cryostat region, at least in the location under the horse collar and at the end of the cable inside the JB. The color bands must be retained at all times and when the excess length is cut and the termination made. All loop installation information and identifiers will be logged in **Table 1, Table 2, or Table 3** at end of procedure which will include loop tag nomenclature and color code number. The standard electrical wiring identifying convention will be used. Two different width bands will be used. The first number is the series will be the wider band with.

**The color identifiers are:**

0=Black	5=Green
1=Brown	6=Blue
2=Red	7=Violet
3=Orange	8=Gray
4=Yellow	9=White

- 6.10.5 Perform final routing of flux leads, holding down twisted flux leads with spot-welded shims stock straps spaced approximately 4" apart.

**Field Period Assembly Station One  
D-NCSX-FPA-001**

- 6.10.6 Install all remaining flux loop templates. Except for the mentioned wire runs in the previous step, all remaining templates shall be installed before any loop wires are run. Verify all templates are best fit to model.

**Metrology Technician and Engineer and Physics Representative See Appendix A – Document Sign-off Record**

- 6.10.7 Install and perform final routing of remaining flux leads.

**NOTE:** The radial build of the twisted leads should not exceed 1/8", except in a few places (not under H/C tube paths) where it may be necessary for one set of leads to cross another.

- 6.10.8 After each twisted pair is installed it must be tested for continuity and resistance of the conductor and integrity of the MGO insulation See: (NCSX CSPEC-310-01). Log the test results for all pairs on **Table 4, Table 5 or Table 6**. A dielectric fixture will be provided to facilitate the testing.

**Lead Technician and QC Representative See Appendix A – Document Sign-off Record**

**6.11 Final Loop Routing and Measurement**

- 6.11.1 Contact Cognizant Engineer to determine which holes through the CF flange and Jb are to be used for cables. The cables are not to be pulled through the CF flange at this time. Assemble the silicone rubber seal between the CF flange and JB lightly tightening the ¼ inch hardware. The predrilled holes for the ¼ inch fasteners will allow orienting the JB properly. Note that most of the JB to CF bolt circle pattern orientation is unique. The JB must be oriented properly on the horse collar. Using a small hypodermic needle (0.014 inches OD) puncture the rubber seal for one hole at first to clock the predrilled holes in the CF flange with the predrilled holes in the JB. Only the predrilled holes to be populated with cable are to have the rubber seal punctured. The non populated holes must have an intact rubber seal to prevent nitrogen boil off. Loosen the ¼ inch hardware and insert the smooth non twisted leads through the drilled holes in the 2.75 CF flange drilled blank, then silicone rubber, and then the JB. Verify that the pattern is as shown on appropriate drawing per Cognizant Engineer. Pull in the cable with the last twist up against the CF flange. Continue the twisting of the leads inside the JB boundary for approximately 3 turns. Do not twist the leads beyond the 3 turns at this time so as not to interfere with the terminations phase of work after machine operations start. After all cables are pulled into a JB square cut the ends to a length of 15 inches and seal the ends with Aero Seal. The color code should be applied and visible inside the JB and below the hoarse collar
- 6.11.2 Remove the winding templates after the loops are formed and twisted leads run to the JB.
- 6.11.3 Using an exciter coil verifies that the proper coil leads are in the proper holes.

## Field Period Assembly Station One D-NCSX-FPA-001

- 6.11.4 Measure as-built paths of flux loops within  $\pm 0.25$  mm (0.01") in the lateral dimension. Each flux loop position and geometry is to be measured by using a Romer Arm with a small tip or the Laser Tracker and tracing the interface (groove) between the two turns. The measurement should be made a minimum of every one inch. In addition the triangular open area, formed at the point where the twisting of leads start and end, is to be measured and documented as a continuous geometry. The measurement should be logged into a table of xyz coordinates which can be read by the Physics Group.

**Note: Log continuity check and tagging on Table 4, Table 5 or Table 6.**

**Metrology Technician and Engineer and Physics Representative See Appendix A – Document Sign-off Record**

### 6.12 Thermocouple installation

- 6.12.1 Using Reference drawing: se121-004 install thermocouples *to port 12 and VV shell*.
- 6.12.2 Perform electrical isolation check and an operation check on the thermocouples as per NCSX-CSPEC-185-01. In addition, the temperature indicated by each thermocouple must be within 2° C of expected temperature.

The resistance between the vacuum vessel and each of the thermocouple elements shall be checked to assure that it is greater than 1.5 Mohms at a minimum of 500V. Revised NCR 3719 dispositioned nonconformances to "use as is" and permitted readings of >0.4 MOhms at a minimum of 500V.

**Lead Technician and QC Representative See Appendix A – Document Sign-off Record**

### 6.13 Installation of H/C lines

- 6.13.1 Install remaining H/C studs on the VV being careful not to damage Flux Loops.
- 6.13.2 Install H/C support bracket Weldment A and B and tube mount strap. See **Figure 13**. and Reference Drawing: se123-049.

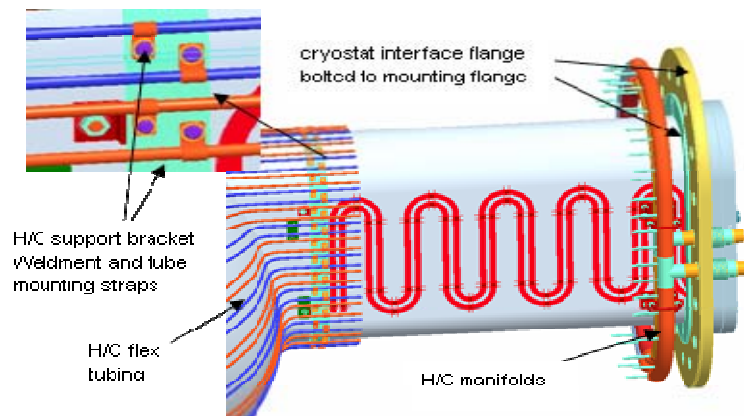

**Figure 13 H/C Support Brackets**

**Field Period Assembly Station One  
D-NCSX-FPA-001**

6.13.3 Using reference Drawings: sse121-008, Install H/C cryostat flange and H/C manifolds. See **Figure 13**.

**Lead Technician and QC Representative See Appendix A – Document Sign-off Record**

6.13.4 Using reference Drawings: sse121-008, Install H/C flex tubing. Torque stud nuts to 65in-lbs. Log torque data on **Table 8** at end of procedure. See **Figure 13**.

**Lead Technician and QC Representative See Appendix A – Document Sign-off Record**

6.13.5 Using reference Drawings: sse121-008, Install H/C hard tubing. Log data on Table 5 at end of procedure. See **Figure 14**.

**Lead Technician and QC Representative See Appendix A – Document Sign-off Record**

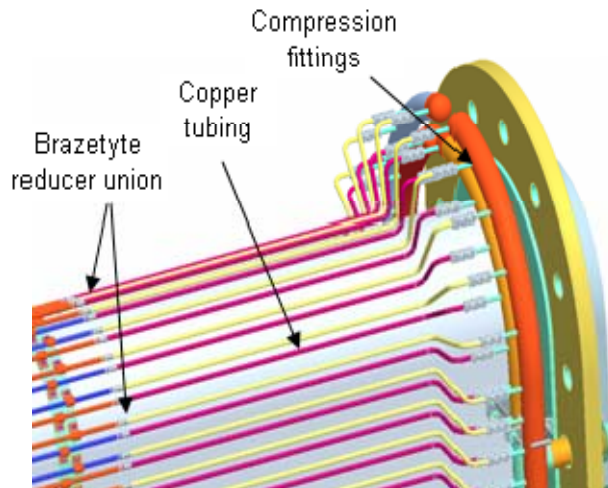

**Figure 14 Hard Tube Installations**

6.13.6 Leak check and flow check coolant lines. Using NCSX-CSPEC-185-01 and engineering procedure ENG-014 (guidelines for Hydrostatic testing) test the individual cooling lines.

**Note: Log leak check flow on Table 8 - H/C Lines Installation and Leak Check Data**

**Lead Technician and QC Representative See Appendix A – Document Sign-off Record**

**Field Period Assembly Station One  
D-NCSX-FPA-001**

6.13.7 Re-torque heating/coolant stud clamps to 65in-lbs.

**Lead Technician and QC Representative See Appendix A – Document Sign-off Record**

**Field Period Assembly Station One  
D-NCSX-FPA-001**

**7. Completion of Activities at Station One:**

**7.1 Document Verification:**

Verify that all pertinent data in the procedure **Table 1** through **Table 8**, and Appendix A have been completed.

**7.2 Field Package:**

Ensure that all data sheets, photographs, QC inspection sheets, etc are included in the Field Package.

**7.3 Approval:**

Prior to releasing a VV from Station One it is required that the all-responsible individuals sign the release indicating that all processes at the station one have been satisfactorily completed. The release will include signatures from the Station Lead Technician, Field Supervisor and the QC representative.

All station one preparation activities including completion of appendix one and **Table 1** through **Table 8**, have been satisfactorily completed.

**QC shall verify completion of documentation:**

<b>Quality Control Representative See Appendix A – Document Sign-off Record</b>
---

**The VV is ready for transfer to the VV station no. 3:**

<b>Lead Technician, Field Supervisor, and QC Representative See Appendix A – Document Sign-off Record</b>
---

**7.4 Preparing and Transferring Completed VV to Holding Area**

- 7.4.1 Install the NB port temporary cover and NB angle support bracket. See **Figure 15**.
- 7.4.2 Rotate VV to horizontal position. Secure in place by bolting down support axle cradle top support blocks and installing quick release pin.
- 7.4.3 Remove worm gear and install hoist rings.
- 7.4.4 Using lift procedure D-L-NCSX-997 remove completed VV from support stand and reposition to the vertical position with worm gear side of vessel in the down position.
- 7.4.5 While on the crane install base support plate. See **Figure 16**.



**Field Period Assembly Station One  
D-NCSX-FPA-001**

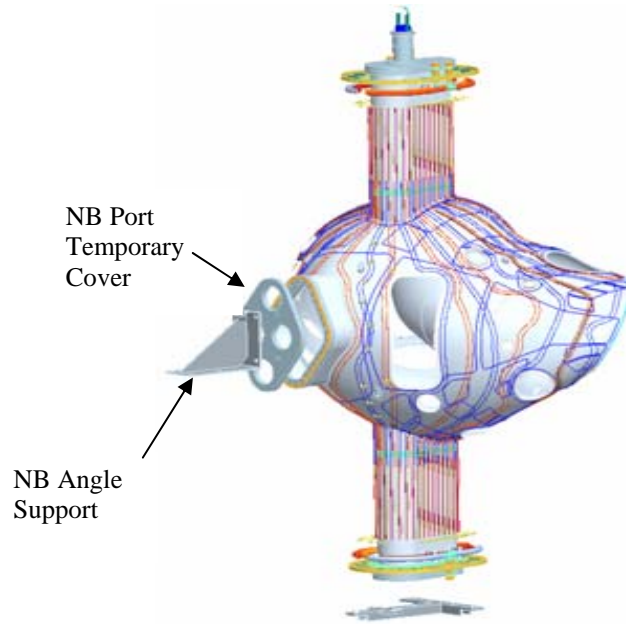

**Figure 15 NB Angle Support Bracket and Base Support Plate**

7.4.6 Position completed VV on Station 3 stand. See **Figure 16**.

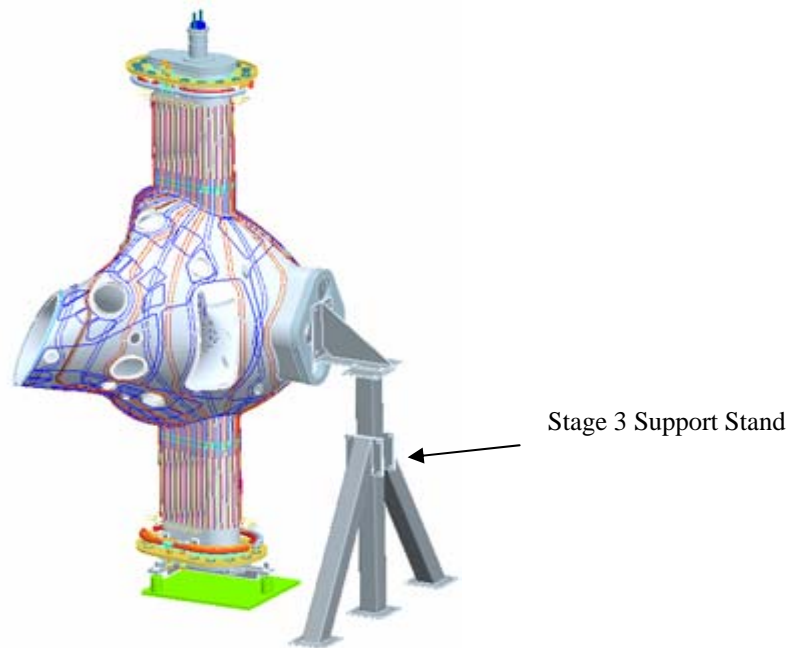

**Figure 16 Stage 3 Support Stand**

**Field Period Assembly Station One  
D-NCSX-FPA-001**

**Appendix A. Document Sign Off**

**1.3 Vacuum Vessel Segment Identification**

<b>Segment Identification</b> _____ <b>Verified by:</b> _____ <b>Date:</b> _____ <b>Lead Technician</b>
---

**4.1 Pre Job Briefing:**

<b>Pre Job Briefing Complete:</b> _____ <b>Date:</b> _____ <b>VV Field Supervisor</b>
--

**6.4.7 Rotating fixture secure:**

<b>Verified by:</b> _____ <b>Date:</b> _____ <b>Lead Technician</b>
--

**6.4.8 Cg verification:**

<b>Verified by:</b> _____ <b>Date:</b> _____ <b>Lead Technician</b>
--

**6.5.1 Arrows marked for toroidal field direction:**

<b>Verified by:</b> _____ <b>Date:</b> _____ <b>Lead Technician</b>
--

**6.5.4 Best fit to Fiducials:**

<b>Measurements taken by:</b> _____ <b>Date:</b> _____
--

<b>Measurements verified and /or approved by:</b> _____ <b>Date:</b> _____  <b>Metrology Engineer:</b> _____ <b>Date:</b> _____
---

**Field Period Assembly Station One  
D-NCSX-FPA-001**

**6.7.2 Heating/cooling studs:**

<b>Verified by:</b> _____	<b>Date:</b> _____
<b>Lead Technician</b>	
<b>QC Representative:</b> _____	<b>Date:</b> _____

**6.8.3 Cryostat Interface Flange:**

<b>Verified by:</b> _____	<b>Date:</b> _____
<b>Lead Technician</b>	
<b>QC Representative:</b> _____	<b>Date:</b> _____

**6.8.4 Heating/cooling header bracket**

<b>Verified by:</b> _____	<b>Date:</b> _____
<b>Lead Technician</b>	
<b>QC Representative:</b> _____	<b>Date:</b> _____

**6.8.5 Thermocouple mounting plates:**

<b>Verified by:</b> _____	<b>Date:</b> _____
<b>Lead Technician</b>	
<b>QC Representative:</b> _____	<b>Date:</b> _____

**6.8.6 Heating/cooling support brackets**

<b>Verified by:</b> _____	<b>Date:</b> _____
<b>Lead Technician</b>	
<b>QC Representative:</b> _____	<b>Date:</b> _____

**Field Period Assembly Station One  
D-NCSX-FPA-001**

**6.8.7 Heating strips**

<b>Verified by:</b> _____	<b>Date:</b> _____
<b>Lead Technician</b>	
<b>QC Representative:</b> _____	<b>Date:</b> _____

**6.8.7.1 Heating strips continuity and isolation test.**

<b>Verified by:</b> _____	<b>Date:</b> _____
<b>Lead Technician</b>	
<b>QC Representative:</b> _____	<b>Date:</b> _____

**6.10.6 Loop Templates best fit to Model:**

<b>Measurements taken by:</b> _____	<b>Date:</b> _____
-------------------------------------	--------------------

<b>Measurements verified and/or approved by:</b>	
<b>Metrology Engineer:</b> _____	<b>Date:</b> _____
<b>Physics Representative:</b> _____	<b>Date:</b> _____

**6.10.8 Loop Continuity and resistance check:**

<b>Verified by:</b> _____	<b>Date:</b> _____
<b>Lead Technician</b>	
<b>QC Representative:</b> _____	<b>Date:</b> _____

**Field Period Assembly Station One  
D-NCSX-FPA-001**

**6.11.4 Final Loop Measurements:**

<b>Measurements taken by:</b> _____ <b>Date:</b> _____
--

Measurements verified and/or approved by:
<b>Metrology Engineer:</b> _____ <b>Date:</b> _____
<b>Physics Representative:</b> _____ <b>Date:</b> _____

**6.12.2 Thermocouple electrical isolation and operation check.**

<b>Verified by:</b> _____ <b>Date:</b> _____ <b>Lead Technician</b>
<b>QC Representative:</b> _____ <b>Date:</b> _____

**6.13.3 Heating/cooling manifold**

<b>Verified by:</b> _____ <b>Date:</b> _____ <b>Lead Technician</b>
<b>QC Representative:</b> _____ <b>Date:</b> _____

**6.13.4 Heating/cooling tube stud torque:**

<b>Verified by:</b> _____ <b>Date:</b> _____ <b>Lead Technician</b>
<b>QC Representative:</b> _____ <b>Date:</b> _____

**6.13.5 Heating cooling hard tubing:**

<b>Verified by:</b> _____ <b>Date:</b> _____ <b>Lead Technician</b>
<b>QC Representative:</b> _____ <b>Date:</b> _____

**Field Period Assembly Station One  
D-NCSX-FPA-001**

**6.13.6 Leak Check Coolant Linen:**

<b>Verified by:</b> _____	<b>Date:</b> _____
<b>Lead Technician</b>	
<b>QC Representative:</b> _____	<b>Date:</b> _____

**6.13.7 Heating/cooling tube stud re-torque:**

<b>Verified by:</b> _____	<b>Date:</b> _____
<b>Lead Technician</b>	
<b>QC Representative:</b> _____	<b>Date:</b> _____

**7.3 Approval:**

**QC shall verify completion of documentation:**

<b>Quality Control Representative:</b> _____	<b>Date:</b> _____
--	--------------------

**The VV is ready for transfer to the VV station no. 3:**

<b>Lead Technician:</b> _____	<b>Date:</b> _____
<b>Field Supervisor:</b> _____	<b>Date:</b> _____
<b>Quality Control Representative:</b> _____	<b>Date:</b> _____

**Field Period Assembly Station One  
D-NCSX-FPA-001**

**Table 1-Loop Installation Data for Field Period 1**

Loop ID	Metrology Position	Initial Points Located	Template Placed	Template Verified	Loops Placed	Loop Measured Length	Loop Length Verified	Continuity Checked	Tagging Verified	Comments
AA1										
CC3										
CC5										
D1										
D3										
D7										
DD7										
E1										
E4										
EE4										
F2										
F4										
F6										
F10										
FF2										
FF4										
FF5										
G7										
GG1										
GG3										
GG5										
GG9										
GG11										
H4										
H8										

**Field Period Assembly Station One  
D-NCSX-FPA-001**

**Table 1-Loop Installation Data for Field Period 1 (continued)**

Loop ID	Metrology Position	Initial Points Located	Template Placed	Template Verified	Loops Placed	Loop Measured Length	Loop Length Verified	Continuity Checked	Tagging Verified	Comments
HH6										
HH9										
I7										
JJ5										
K2										
K4										
K7										
K11										
KK3										
KK9										
L6										
L9										
LL5										
M2										
M9										
MM1										
MM10										
N3										
N5										
N6										
N8										
N9										
NN4										
NN8										
NN11										



**Field Period Assembly Station One  
D-NCSX-FPA-001**

**Table 1-Loop Installation Data for Field Period 1 (continued)**

Loop ID	Metrology Position	Initial Points Located	Template Placed	Template Verified	Loops Placed	Loop Measured Length	Loop Length Verified	Continuity Checked	Tagging Verified	Comments
O6										
OO5										
OO8										
P2										
PP3										
THO-1										
THO-2										
THO-3										
THO-4										
THO-5										
TH180-1										
TH180-2										
TH180-3										
TH180-4										
TH180-5										

Field Period Assembly Station One  
D-NCSX-FPA-001

Table 2 Loop Installation Data for Field Period 2

Loop ID	Metrology Position	Initial Points Located	Template Placed	Template Verified	Loops Placed	Loop Measured Length	Loop Length Verified	Continuity Checked	Tagging Verified	Comments
AA2										
B2										
C1										
<b>C4</b>										
CC4										
D4										
D5										
DD2										
DD5										
E2										
EE7										
F8										
F11										
FF3										
FF7										
G1										
G4										
G9										
GG10										
H5										
HH2										
HH5										
HH8										

**Field Period Assembly Station One  
D-NCSX-FPA-001**

**Table 2 Loop Installation Data for Field Period 2 (continued)**

Loop ID	Metrology Position	Initial Points Located	Template Placed	Template Verified	Loops Placed	Loop Measured Length	Loop Length Verified	Continuity Checked	Tagging Verified	Comments
HH10										
I4										
II1										
II2										
II3										
II4										
II5										
II6										
II7										
II8										
II9										
J1										
J2										
J3										
J4										
J5										
J6										
J7										
J8										
J9										
J10										
JJ2										
K5										
KK11										

**Field Period Assembly Station One  
D-NCSX-FPA-001**

**Table 2 Loop Installation Data for Field Period 2 (continued)**

Loop ID	Metrology Position	Initial Points Located	Template Placed	Template Verified	Loops Placed	Loop Measured Length	Loop Length Verified	Continuity Checked	Tagging Verified	Comments
L1										
L3										
LL2										
LL4										
LL7										
M4										
MM5										
N2										
N7										
NN1										
NN3										
O7										
O10										
OO8										
PP4										
THO-1										
THO-2										
THO-3										
THO-4										
THO-5										
THO1 80-1										
THO1 80-2										

**Field Period Assembly Station One  
D-NCSX-FPA-001**

**Table 3 Loop Installation Data For Field Period 3**

Loop ID	Metrology Position	Initial Points Located	Template Placed	Template Verified	Loops Placed	Loop Measured Length	Loop Length Verified	Continuity Checked	Tagging Verified	Comments
B1										
B4										
BB3										
CC2										
D6										
DD3										
DD4										
E3										
E4										
E5										
F5										
EE6										
F9										
FF1										
FF9										
G2										
G8										
GG6										
H1										
H3										
HH4										
H11										
HH7										

**Field Period Assembly Station One  
D-NCSX-FPA-001**

**Table 3 Loop Installation Data For Field Period 3 (continued)**

Loop ID	Metrology Position	Initial Points Located	Template Placed	Template Verified	Loops Placed	Loop Measured Length	Loop Length Verified	Continuity Checked	Tagging Verified	Comments
I2										
I8										
JJ4										
JJ8										
K6										
KK1										
KK4										
KK7										
KK8										
KK10										
L2										
L4										
L8										
LL8										
LL10										
M3										
M7										
M8										
MM6										
MM8										
MM11										
N10										
O1										
O4										
O9										

**Field Period Assembly Station One  
D-NCSX-FPA-001**

**Table 3 Loop Installation Data For Field Period 3 (continued)**

Loop ID	Metrology Position	Initial Points Located	Template Placed	Template Verified	Loops Placed	Loop Measured Length	Loop Length Verified	Continuity Checked	Tagging Verified	Comments
O11										
OO2										
OO3										
OO4										
OO7										
OO10										
PP1										
Q2										
QQ1										
THO-1										
THO-2										
THO-3										
THO-4										
THO-5										
TH180 -1										
TH180 -2										
TH180 -3										
TH180 -4										
TH180 -5										

**Field Period Assembly Station One  
D-NCSX-FPA-001**

**Table 4 Loop Placement Data for Field Period - Sheet 1**

Loop ID	Colors	Series R (Ohms)	Capacitance Nf = 100 pf	Leakage (MOhms)	Total Length (Inches)	Comments
AA1	Black & Brown					
CC3	Black & Red					
CC5	Black & Orange					
D1	Black & Yellow					
D3	Black & Green					
D7	Black & Blue					
DD7	Black Violet					
E1	Black & Gray					
E4	Black & White					
EE4	Brown & Black					
F2	Brown & Brown					
F4	Brown & Red					
F6	Brown & Orange					
F10	Brown & Yellow					
FF2	Brown & Green					
FF4	Brown & Blue					



**Field Period Assembly Station One  
D-NCSX-FPA-001**

**Table 4 - Loop Placement Data for Field Period 1 - Sheet 1 (continued)**

<b>Loop ID</b>	<b>Colors</b>	<b>Series R (Ohms)</b>	<b>Capacitance Nf = 100 pf</b>	<b>Leakage (MOhms)</b>	<b>Total Length (Inches)</b>	<b>Comments</b>
FF5	Black & Violet					
G7	Brown & Gray					
GG1	Brown & White					
GG3	Red & Black					
GG5	Red & Brown					
GG9	Red & Red					
GG11	Red & Orange					
H4	Red & Yellow					
H8	Red & Green					

**Field Period Assembly Station One  
D-NCSX-FPA-001**

**Table 4 - Loop Placement Data for Field Period 1- Sheet 2**

<b>Loop ID</b>	<b>Colors</b>	<b>Series R (Ohms)</b>	<b>Capacitance Nf = 100 pf</b>	<b>Leakage (MOhms)</b>	<b>Total Length (Inches)</b>	<b>Comments</b>
HH6	Red & Blue					
HH9	Red & Violet					
I7	Red & Gray					
JJ5	Red & White					
K2	Orange & Black					
K4	Orange & Brown					
K7	Orange & Red					
KK1	Orange & Orange					
KK3	Orange & Yellow					
KK9	Orange & Green					
L6	Orange & Blue					
L9	Orange & Violet					
LL5	Orange & Gray					
M2	Orange & White					
M9	Yellow & Black					
MM1	Yellow & Brown					

**Field Period Assembly Station One  
D-NCSX-FPA-001**

**Table 4- Loop Placement Data for Field Period 1 sheet 2 (continued)**

<b>Loop ID</b>	<b>Colors</b>	<b>Series R (Ohms)</b>	<b>Capacitance Nf = 100 pf</b>	<b>Leakage (MOhms)</b>	<b>Total Length (Inches)</b>	<b>Comments</b>
MM10	Yellow & Red					
N3	Yellow & Orange					
N5	Yellow & Yellow					
N6	Yellow & Green					
N8	Yellow & Blue					
N9	Yellow & Violet					
NN4	Yellow & Gray					
NN8	Yellow & White					
NN11	Green & Black					

**Field Period Assembly Station One  
D-NCSX-FPA-001**

**Table 4 - Loop Placement Data for Field Period 1 – Sheet 3**

<b>Loop ID</b>	<b>Colors</b>	<b>Series R (Ohms)</b>	<b>Capacitance Nf = 100 pf</b>	<b>Leakage (MOhms)</b>	<b>Total Length (Inches)</b>	<b>Comments</b>
O6	Green & Brown					
O8	Green & Red					
OO5	Green & Orange					
P2	Green & Yellow					
PP3	Green & Green					
THO-1	Green & BLUE					
THO-2	Green Violet					
THO-3	Green & Gray					
THO-4	Green & White					
THO-5	Blue & Black					
TH180-1	Blue & Brown					
TH180-2	Blue & Red					
TH180-3	Blue & Orange					
TH180-4	Blue & Yellow					
TH180-5	Blue & Green					

**Field Period Assembly Station One  
D-NCSX-FPA-001**

**Table 4 - Loop Placement Data for Field Period 1 –Sheet 3 (continued)**

<b>Loop ID</b>	<b>Colors</b>	<b>Series R (Ohms)</b>	<b>Capacitance Nf = 100 pf</b>	<b>Leakage (MOhms)</b>	<b>Total Length (Inches)</b>	<b>Comments</b>

**Field Period Assembly Station One  
D-NCSX-FPA-001**

**Table 5- Loop Placement Data for Field Period 2 –Sheet 1**

<b>Loop ID</b>	<b>Colors</b>	<b>Series R (Ohms)</b>	<b>Capacitance Nf = 100 pf</b>	<b>Leakage (MOhms)</b>	<b>Total Length (Inches)</b>	<b>Comments</b>
AA2	Black & Brown					
B2	Black & Red					
C1	Black & Orange					
C4	Black & Yellow					
CC4	Black & Green					
D4	Black & Blue					
D5	Black Violet					
DD2	Black & Gray					
DD5	Black & White					
E2	Brown & Black					
EE7	Brown & Brown					
F8	Brown & Red					
F11	Brown & Orange					
FF3	Brown & Yellow					
FF7	Brown & Green					
G1	Brown & Blue					

**Field Period Assembly Station One  
D-NCSX-FPA-001**

**Table 5 - Loop Placement Data for Field Period 2 – Sheet 1 (continued)**

Loop ID	Colors	Series R (Ohms)	Capacitance Nf = 100 pf	Leakage (MOhms)	Total Length (Inches)	Comments
G4	Brown & Violet					
G9	Brown & Gray					
GG10	Brown & White					
H5	Red & Black					
H10	Red & Brown					
HH2	Red & Red					
HH5	Red & Orange					
HH8	Red & Yellow					
I4	Red & Green					

**Field Period Assembly Station One  
D-NCSX-FPA-001**

**Table 5 - Loop Placement Data for Field Period 2 – Sheet 2**

Loop ID	Colors	Series R (Ohms)	Capacitance Nf = 100 pf	Leakage (MOhms)	Total Length (Inches)	Comments
II1	Red & Blue					
II2	Red & Violet					
II3	Red & Gray					
II4	Red & White					
II5	Orange & Black					
II6	Orange & Brown					
II7	Orange & Red					
II8	Orange & Orange					
II9	Orange & Yellow					
J1	Orange & Green					
J2	Orange & Blue					
J3	Orange & Violet					
J4	Orange & Gray					
J5	Orange & White					
J6	Yellow & Black					



**Field Period Assembly Station One  
D-NCSX-FPA-001**

**Table 5 - Loop Placement Data for Field Period 2 Sheet 2 (continued)**

Loop ID	Colors	Series R (Ohms)	Capacitance Nf = 100 pf	Leakage (MOhms)	Total Length (Inches)	Comments
J7	Yellow & Brown					
J8	Yellow & Red					
J9	Yellow & Orange					
J10	Yellow & Yellow					
JJ2	Yellow & Green					
K5	Yellow & Blue					
KK11	Yellow & Violet					
L1	Yellow & Gray					
L3	Yellow & White					
L7	Green & Black					

**Field Period Assembly Station One  
D-NCSX-FPA-001**

**Table 5 - Loop Placement Data for Field Period 2 –Sheet 3**

<b>Loop ID</b>	<b>Colors</b>	<b>Series R (Ohms)</b>	<b>Capacitance Nf = 100 pf</b>	<b>Leakage (MOhms)</b>	<b>Total Length (Inches)</b>	<b>Comments</b>
LL2	Green & Brown					
LL4	Green & Red					
LL7	Green & Orange					
M4	Green & Yellow					
MM5	Green & Green					
N2	Green & BLUE					
N7	Green Violet					
NN1	Green & Gray					
NN3	Green & White					
O7	Blue & Black					
O10	Blue & Brown					
OO8	Blue & Red					
PP4	Blue & Orange					
THO-1	Blue & Yellow					
THO-2	Blue & Green					
THO-3	Blue & Blue					

**Field Period Assembly Station One  
D-NCSX-FPA-001**

**Table 5 - Loop Placement Data for Field Period 2 – Sheet 3 (continued)**

<b>Loop ID</b>	<b>Colors</b>	<b>Series R (Ohms)</b>	<b>Capacitance Nf = 100 pf</b>	<b>Leakage (MOhms)</b>	<b>Total Length (Inches)</b>	<b>Comments</b>
THO-4	Blue & Violet					
THO-5	Blue & Gray					
TH180-1	Blue & White					
TH180-2	Violet & Black					
TH180-3	Violet & Brown					
TH180-4	Violet & Red					
TH180-5	Violet & Orange					

**Field Period Assembly Station One  
D-NCSX-FPA-001**

**Table 6 - Loop Placement Data for Field Period 3 – Sheet 1**

<b>Loop ID</b>	<b>Colors</b>	<b>Series R (Ohms)</b>	<b>Capacitance Nf = 100 pf</b>	<b>Leakage (MOhms)</b>	<b>Total Length (Inches)</b>	<b>Comments</b>
B1	Black & Brown					
B4	Black & Red					
BB3	Black & Orange					
CC2	Black & Yellow					
D6	Black & Green					
DD3	Black & Blue					
DD4	Black Violet					
E3	Black & Gray					
E4	Black & White					
E5	Brown & Black					
EE6	Brown & Brown					
F5	Brown & Red					
F9	Brown & Orange					
FF1	Brown & Yellow					
FF9	Brown & Green					
G2	Brown & Blue					

**Field Period Assembly Station One  
D-NCSX-FPA-001**

**Table 6 - Loop Placement Data for Field Period 3 – Sheet 1 (continued)**

<b>Loop ID</b>	<b>Colors</b>	<b>Series R (Ohms)</b>	<b>Capacitance Nf = 100 pf</b>	<b>Leakage (MOhms)</b>	<b>Total Length (Inches)</b>	<b>Comments</b>
G8	Brown & Violet					
GG6	Brown & Gray					
H1	Brown & White					
H3	Red & Black					
H11	Red & Brown					
HH4	Red & Red					
HH7	Red & Orange					
I2	Red & Yellow					
I8	Red & Green					

**Field Period Assembly Station One  
D-NCSX-FPA-001**

**Table 6 - Loop Placement Data for Field Period 3 –Sheet 2**

<b>Loop ID</b>	<b>Colors</b>	<b>Series R (Ohms)</b>	<b>Capacitance Nf = 100 pf</b>	<b>Leakage (MOhms)</b>	<b>Total Length (Inches)</b>	<b>Comments</b>
JJ4	Red & Blue					
JJ8	Red & Violet					
K6	Red & Gray					
KK1	Red & White					
KK4	Orange & Black					
KK7	Orange & Brown					
KK8	Orange & Red					
KK10	Orange & Orange					
L2	Orange & Yellow					
L4	Orange & Green					
L8	Orange & Blue					
LL8	Orange & Violet					
LL10	Orange & Gray					
M3	Orange & White					
M7	Yellow & Black					
M8	Yellow & Brown					

**Field Period Assembly Station One  
D-NCSX-FPA-001**

**Table 6 - Loop Placement Data for Field Period 3 – Sheet 2 (continued)**

<b>Loop ID</b>	<b>Colors</b>	<b>Series R (Ohms)</b>	<b>Capacitance Nf = 100 pf</b>	<b>Leakage (MOhms)</b>	<b>Total Length (Inches)</b>	<b>Comments</b>
MM6	Yellow & Red					
MM8	Yellow & Orange					
MM11	Yellow & Yellow					
N10	Yellow & Green					
O1	Yellow & Blue					
O4	Yellow & Violet					
O9	Yellow & Gray					
O11	Yellow & White					
OO2	Green & Black					

**Field Period Assembly Station One  
D-NCSX-FPA-001**

**Table 6 - Loop Placement Data for Field Period 3 – Sheet 3**

<b>Loop ID</b>	<b>Colors</b>	<b>Series R (Ohms)</b>	<b>Capacitance Nf = 100 pf</b>	<b>Leakage (MOhms)</b>	<b>Total Length (Inches)</b>	<b>Comments</b>
OO3	Green & Brown					
OO4	Green & Red					
OO7	Green & Orange					
OO10	Green & Yellow					
PP1	Green & Green					
Q2	Green & BLUE					
QQ1	Green Violet					
THO-1	Green & Gray					
THO-2	Green & White					
THO-3	Blue & Black					
THO-4	Blue & Brown					
THO-5	Blue & Red					
TH180-1	Blue & Orange					
TH180-2	Blue & Yellow					
TH180-3	Blue & Green					
TH180-4	Blue & Blue					



**Field Period Assembly Station One  
D-NCSX-FPA-001**

**Table 6 - Loop Placement Data for Field Period 3 – Sheet 3 (continued)**

Loop ID	Colors	Series R (Ohms)	Capacitance Nf = 100 pf	Leakage (MOhms)	Total Length (Inches)	Comments
TH180-5	Blue & Violet					

**Field Period Assembly Station One  
D-NCSX-FPA-001**

**Table 7 - Stud Installation Data**

<b>STUD</b>	<b>STUD LOCATED</b>	<b>STUD PLACED</b>	<b>STUD TORQUED</b>	<b>STUD RE-TORQUED</b>	<b>STUD MEASURED</b>	<b>INSPECTION</b>	<b>COMMENTS</b>
AA-1							
AA-2							
AA-3							
AA-4							
AA-5							
AA-6							
AA-7							
AA-8							
AA-9							
AA-10							
AA-11							
AA-12							
AA-13							
AA-14							
AA-15							
AA-16							
AA-17							
AA-18							
AB-1							
AB-2							

**Field Period Assembly Station One  
D-NCSX-FPA-001**

**Table 7 - Stud Installation Data (continued)**

<b>STUD</b>	<b>STUD LOCATED</b>	<b>STUD PLACED</b>	<b>STUD TORQUED</b>	<b>STUD RE-TORQUED</b>	<b>STUD MEASURED</b>	<b>INSPECTION</b>	<b>COMMENTS</b>
AB-3							
AB-4							
AB-5							
AB-6							
AB-7							
AB-8							
AB-9							
AB-10							
AB-11							
AB-12							
AB-13							
AB-14							
AB-15							
AB-16							
AB-17							
AC-1							
AC-2							
AC-3							
AC-4							

**Field Period Assembly Station One  
D-NCSX-FPA-001**

**Table 7 - Stud Installation Data (continued)**

STUD	STUD LOCATED	STUD PLACED	STUD TORQUED	STUD RE-TORQUED	STUD MEASURED	INSPECTION	COMMENTS
AC-5							
AC-6							
AC-7							
AC-8							
AC-9							
AC-10							
AC-11							
AC-12							
AC-13							
AC-14							
AC-15							
AC-16							
AD-1							
AD-2							
AD-3							
AD-4							
AD-5							
AD-6							
AD-7							
AD-8							

**Field Period Assembly Station One  
D-NCSX-FPA-001**

**Table 7 - Stud Installation Data (continued)**

<b>STUD</b>	<b>STUD LOCATED</b>	<b>STUD PLACED</b>	<b>STUD TORQUED</b>	<b>STUD RE-TORQUED</b>	<b>STUD MEASURED</b>	<b>INSPECTION</b>	<b>COMMENTS</b>
AD-9							
AD-10							
AD-11							
AD-12							
AD-13							
AD-14							
AD-15							
AD-16							
AD-17							
AD-18							
AD-19							
AD-20							
AE-1							
AE-2							
AE-3							
AE-4							
AE-5							
AE-6							
AE-7							
AE-8							

**Field Period Assembly Station One  
D-NCSX-FPA-001**

**Table 7 - Stud Installation Data (continued)**

STUD	STUD LOCATED	STUD PLACED	STUD TORQUED	STUD RE-TORQUED	STUD MEASURED	INSPECTION	COMMENTS
AE-9							
AE-10							
AE-11							
AE-12							
AE-13							
AE-14							
AE-15							
AE-16							
AE-17							
AE-18							
AE-19							
AF-20							
AF-1							
AF-2							
AF-3							
AF-4							
AF-5							
AF-6							
AF-7							
AF-8							
AF-9							

**Field Period Assembly Station One  
D-NCSX-FPA-001**

**Table 7 - Stud Installation Data (continued)**

<b>STUD</b>	<b>STUD LOCATED</b>	<b>STUD PLACED</b>	<b>STUD TORQUED</b>	<b>STUD RE-TORQUED</b>	<b>STUD MEASURED</b>	<b>INSPECTION</b>	<b>COMMENTS</b>
AF-10							
AF-11							
AF-12							
AF-13							
AF-14							
AF-15							
AF-16							
AF-17							
AF-18							
AF-19							
AF_20							
AG-1							
AG-2							
AG-3							
AG-4							
AG-5							
AG-6							
AG-7							
AG-8							
AG-9							

**Field Period Assembly Station One  
D-NCSX-FPA-001**

**Table 7 - Stud Installation Data (continued)**

STUD	STUD LOCATED	STUD PLACED	STUD TORQUED	STUD RE-TORQUED	STUD MEASURED	INSPECTION	COMMENTS
AG-10							
AG-11							
AG-12							
AG-13							
AG-14							
AG-15							
AG-16							
AG-17							
AG-18							
AG-19							
AG-20							
AG-21							
AG-22							
AG-23							
AG-24							
AH-1							
AH-2							
AH-3							
AH-4							
AH-5							



**Field Period Assembly Station One  
D-NCSX-FPA-001**

**Table 7 - Stud Installation Data (continued)**

<b>STUD</b>	<b>STUD LOCATED</b>	<b>STUD PLACED</b>	<b>STUD TORQUED</b>	<b>STUD RE-TORQUED</b>	<b>STUD MEASURED</b>	<b>INSPECTION</b>	<b>COMMENTS</b>
AH-6							
AH-7							
AH-8							
AH-9							
AH-10							
AH-11							
AH-12							
AH-13							
AH-14							
AH-15							
AH-16							
AH-17							
AH-18							
AH-19							
AH-20							
AH-21							
AH-22							
AH-23							
AH-24							
AH-25							
AH-26							

**Field Period Assembly Station One  
D-NCSX-FPA-001**

**Table 7 - Stud Installation Data (continued)**

<b>STUD</b>	<b>STUD LOCATED</b>	<b>STUD PLACED</b>	<b>STUD TORQUED</b>	<b>STUD RE-TORQUED</b>	<b>STUD MEASURED</b>	<b>INSPECTION</b>	<b>COMMENTS</b>
AH-27							
AH-28							
AJ-1							
AJ-2							
AJ-3							
AJ-4							
AJ-5							
AJ-6							
AJ-7							
AJ-8							
AJ-9							
AJ-10							
AJ-11							
AJ-12							
AJ-13							
AJ-14							
AJ-15							
AJ-16							
AJ-17							
AJ-19							

**Field Period Assembly Station One  
D-NCSX-FPA-001**

**Table 7 - Stud Installation Data (continued)**

<b>STUD</b>	<b>STUD LOCATED</b>	<b>STUD PLACED</b>	<b>STUD TORQUED</b>	<b>STUD RE-TORQUED</b>	<b>STUD MEASURED</b>	<b>INSPECTION</b>	<b>COMMENTS</b>
AJ-20							
AJ-21							
AJ-22							
AJ-23							
AJ-24							
AJ-25							
AJ-26							
AJ-27							
AJ-28							
AJ-29							
AK-1							
AK-2							
AK-3							
AK-4							
AK-5							
AK-6							
AK-7							
AK-8							
AK-9							
AK-10							

**Field Period Assembly Station One  
D-NCSX-FPA-001**

**Table 7 - Stud Installation Data (continued)**

<b>STUD</b>	<b>STUD LOCATED</b>	<b>STUD PLACED</b>	<b>STUD TORQUED</b>	<b>STUD RE-TORQUED</b>	<b>STUD MEASURED</b>	<b>INSPECTION</b>	<b>COMMENTS</b>
AK-11							
AK-12							
AK-13							
AK-14							
AK-15							
AK-16							
AK-17							
AK-18							
AK-19							
AK-20							
AK-21							
AK-22							
AK-23							
AK-24							
AK-25							
AK-26							
AK-27							
AK-28							
AK-29							
AK-30							
AK-31							

**Field Period Assembly Station One  
D-NCSX-FPA-001**

**Table 7 - Stud Installation Data (continued)**

<b>STUD</b>	<b>STUD LOCATED</b>	<b>STUD PLACED</b>	<b>STUD TORQUED</b>	<b>STUD RE-TORQUED</b>	<b>STUD MEASURED</b>	<b>INSPECTION</b>	<b>COMMENTS</b>
AK-32							
AK-33							
AL-1							
AL-2							
AL-3							
AL-4							
AL-5							
AL-6							
AL-7							
AL-8							
AL-9							
AL-10							
AL-11							
AL-12							
AL-13							
AL-14							
AL-15							
AL-16							
AL-17							
AL-18							

**Field Period Assembly Station One  
D-NCSX-FPA-001**

**Table 7 - Stud Installation Data (continued)**

STUD	STUD LOCATED	STUD PLACED	STUD TORQUED	STUD RE-TORQUED	STUD MEASURED	INSPECTION	COMMENTS
AL-19							
AL-20							
AL-21							
AL-22							
AL-23							
AL-24							
AL-25							
AL-26							
AL-27							
AL-28							
AL-29							
AL-30							
AL-31							
AL-32							
AL-33							
AL-34							
AM-1							
AM-2							
AM-3							
AM-4							

**Field Period Assembly Station One  
D-NCSX-FPA-001**

**Table 7 - Stud Installation Data (continued)**

STUD	STUD LOCATED	STUD PLACED	STUD TORQUED	STUD RE-TORQUED	STUD MEASURED	INSPECTION	COMMENTS
AM-5							
AM-6							
AM-7							
AM-8							
AM-9							
AM-10							
AM-11							
AM-12							
AM-13							
AM-14							
AM-15							
AM-16							
AM-17							
AM-18							
AM-19							
AM-20							
AM-21							
AM-22							
AM-23							
AM-24							

**Field Period Assembly Station One  
D-NCSX-FPA-001**

**Table 7 - Stud Installation Data (continued)**

<b>STUD</b>	<b>STUD LOCATED</b>	<b>STUD PLACED</b>	<b>STUD TORQUED</b>	<b>STUD RE-TORQUED</b>	<b>STUD MEASURED</b>	<b>INSPECTION</b>	<b>COMMENTS</b>
AN-1							
AN-2							
AN-3							
AN-4							
AN-5							
AN-6							
AN-7							
AN-8							
AN-9							
AN-10							
AN-11							
AN-12							
AN-13							
AN-14							
AN-15							
AN-16							
AN-17							
AN-18							
AN-19							
AN-20							
AN-21							



**Field Period Assembly Station One  
D-NCSX-FPA-001**

**Table 7 - Stud Installation Data (continued)**

<b>STUD</b>	<b>STUD LOCATED</b>	<b>STUD PLACED</b>	<b>STUD TORQUED</b>	<b>STUD RE-TORQUED</b>	<b>STUD MEASURED</b>	<b>INSPECTION</b>	<b>COMMENTS</b>
AN-22							
AP-1							
AP-2							
AP-3							
AP-4							
AP-5							
AP-6							
AP-7							
AP-8							
AP-9							
AP-10							
AP-11							
AP-12							
AP-13							
AP-14							
AP-15							
AP-16							
AP-17							
AP-18							
AP-19							

**Field Period Assembly Station One  
D-NCSX-FPA-001**

**Table 7 - Stud Installation Data (continued)**

STUD	STUD LOCATED	STUD PLACED	STUD TORQUED	STUD RE-TORQUED	STUD MEASURED	INSPECTION	COMMENTS
AP-20							
AP-21							
AQ-1							
AQ-2							
AQ-3							
AQ-4							
AQ-5							
AQ-6							
AQ-7							
AQ-8							
AQ-9							
AQ-10							
AQ-11							
AQ-12							
AQ-13							
AQ-14							
AQ-15							
AQ-16							
AQ-17							
AQ-18							

**Field Period Assembly Station One  
D-NCSX-FPA-001**

**Table 7 - Stud Installation Data (continued)**

<b>STUD</b>	<b>STUD LOCATED</b>	<b>STUD PLACED</b>	<b>STUD TORQUED</b>	<b>STUD RE-TORQUED</b>	<b>STUD MEASURED</b>	<b>INSPECTION</b>	<b>COMMENTS</b>
AQ-19							
AQ-20							
AR-1							
AR-2							
AR-3							
AR-4							
AR-5							
AR-6							
AR-7							
AR-8							
AR-9							
AR-10							
AR-11							
AR-12							
AR-13							
AR-14							
AR-15							
AR-16							
AR-17							
AR-18							

**Field Period Assembly Station One  
D-NCSX-FPA-001**

**Table 7 - Stud Installation Data (continued)**

<b>STUD</b>	<b>STUD LOCATED</b>	<b>STUD PLACED</b>	<b>STUD TORQUED</b>	<b>STUD RE-TORQUED</b>	<b>STUD MEASURED</b>	<b>INSPECTION</b>	<b>COMMENTS</b>
AR-19							
BA-1							
BA-2							
BA-3							
BA-4							
BA-5							
BA-6							
BA-7							
BA-8							
BA-9							
BA-10							
BA-11							
BA-12							
BA-13							
BA-14							
BA-15							
BA-16							
BA-17							
BA-18							

**Field Period Assembly Station One  
D-NCSX-FPA-001**

**Table 7 - Stud Installation Data (continued)**

<b>STUD</b>	<b>STUD LOCATED</b>	<b>STUD PLACED</b>	<b>STUD TORQUED</b>	<b>STUD RE-TORQUED</b>	<b>STUD MEASURED</b>	<b>INSPECTION</b>	<b>COMMENTS</b>
BB-1							
BB-2							
BB-3							
BB-4							
BB-5							
BB-6							
BB-7							
BB-8							
BB-9							
BB-10							
BB-11							
BB-12							
BB-13							
BB-14							
BB-15							
BB-16							
BB-17							
BC-1							
BC-2							
BC-3							

**Field Period Assembly Station One  
D-NCSX-FPA-001**

**Table 7 - Stud Installation Data (continued)**

<b>STUD</b>	<b>STUD LOCATED</b>	<b>STUD PLACED</b>	<b>STUD TORQUED</b>	<b>STUD RE-TORQUED</b>	<b>STUD MEASURED</b>	<b>INSPECTION</b>	<b>COMMENTS</b>
BC-4							
BC-5							
BC-6							
BC-7							
BC-8							
BC-9							
BC-10							
BC-11							
BC-12							
BC-13							
BC-14							
BC-15							
BC-16							
BD-1							
BD-2							
BD-3							
BD-4							
BD-5							
BD-6							
BD-7							

**Field Period Assembly Station One  
D-NCSX-FPA-001**

**Table 7 - Stud Installation Data (continued)**

STUD	STUD LOCATED	STUD PLACED	STUD TORQUED	STUD RE-TORQUED	STUD MEASURED	INSPECTION	COMMENTS
BD-8							
BD-9							
BD-10							
BD-11							
BD-12							
BD-13							
BD-14							
BD-15							
BD-16							
BD-17							
BD-18							
BD-19							
BD-20							
BE-1							
BE-2							
BE-3							
BE-4							
BE-5							
BE-6							
BE-7							

**Field Period Assembly Station One  
D-NCSX-FPA-001**

**Table 7 - Stud Installation Data (continued)**

<b>STUD</b>	<b>STUD LOCATED</b>	<b>STUD PLACED</b>	<b>STUD TORQUED</b>	<b>STUD RE-TORQUED</b>	<b>STUD MEASURED</b>	<b>INSPECTION</b>	<b>COMMENTS</b>
BE-8							
BE-9							
BE-10							
BE-11							
BE-12							
BE-13							
BE-14							
BE-15							
BE-16							
BE-17							
BE-18							
BE-19							
BF-1							
BF-2							
BF-3							
BF-4							
BF-5							
BF-6							
BF-7							
BF-8							



**Field Period Assembly Station One  
D-NCSX-FPA-001**

**Table 7 - Stud Installation Data (continued)**

<b>STUD</b>	<b>STUD LOCATED</b>	<b>STUD PLACED</b>	<b>STUD TORQUED</b>	<b>STUD RE-TORQUED</b>	<b>STUD MEASURED</b>	<b>INSPECTION</b>	<b>COMMENTS</b>
BF-9							
BF-10							
BF-11							
BF-12							
BF-13							
BF-14							
BF-15							
BF-16							
BF-17							
BF-18							
BF-19							
BF-20							
BF-21							
BG-1							
BG-2							
BG-3							
BG-4							
BG-5							
BG-6							
BG-7							

**Field Period Assembly Station One  
D-NCSX-FPA-001**

**Table 7 - Stud Installation Data (continued)**

<b>STUD</b>	<b>STUD LOCATED</b>	<b>STUD PLACED</b>	<b>STUD TORQUED</b>	<b>STUD RE-TORQUED</b>	<b>STUD MEASURED</b>	<b>INSPECTION</b>	<b>COMMENTS</b>
BG-8							
BG-9							
BG-10							
BG-11							
BG-12							
BG-13							
BG-14							
BG-15							
BG-16							
BG-17							
BG-18							
BG-19							
BG-20							
BG-21							
BG-22							
BG-23							
BG-24							
BH-1							
BH-2							
BH-3							

**Field Period Assembly Station One  
D-NCSX-FPA-001**

**Table 7 - Stud Installation Data (continued)**

<b>STUD</b>	<b>STUD LOCATED</b>	<b>STUD PLACED</b>	<b>STUD TORQUED</b>	<b>STUD RE-TORQUED</b>	<b>STUD MEASURED</b>	<b>INSPECTION</b>	<b>COMMENTS</b>
BH-4							
BH-5							
BH-6							
BH-7							
BH-8							
BH-9							
BH-10							
BH-11							
BH-12							
BH-13							
BH-14							
BH-15							
BH-16							
BH-17							
BH-18							
BH-19							
BH-20							
BH-21							
BH-22							
BH-23							
BH-24							

**Field Period Assembly Station One  
D-NCSX-FPA-001**

**Table 7 - Stud Installation Data (continued)**

<b>STUD</b>	<b>STUD LOCATED</b>	<b>STUD PLACED</b>	<b>STUD TORQUED</b>	<b>STUD RE-TORQUED</b>	<b>STUD MEASURED</b>	<b>INSPECTION</b>	<b>COMMENTS</b>
BH-25							
BH-26							
BH-27							
BH-28							
BJ-1							
BJ-2							
BJ-3							
BJ-4							
BJ-5							
BJ-6							
BJ-7							
BJ-8							
BJ-9							
BJ-10							
BJ-11							
BJ-12							
BJ-13							
BJ-14							
BJ-15							
BJ-16							

**Field Period Assembly Station One  
D-NCSX-FPA-001**

**Table 7 - Stud Installation Data (continued)**

<b>STUD</b>	<b>STUD LOCATED</b>	<b>STUD PLACED</b>	<b>STUD TORQUED</b>	<b>STUD RE-TORQUED</b>	<b>STUD MEASURED</b>	<b>INSPECTION</b>	<b>COMMENTS</b>
BJ-17							
BJ-18							
BJ-19							
BJ-20							
BJ-21							
BJ-22							
BJ-23							
BJ-24							
BJ-25							
BJ-26							
BJ-27							
BJ-28							
BJ-29							
BK-1							
BK-2							
BK-3							
BK-4							
BK-5							
BK-6							
BK-7							

**Field Period Assembly Station One  
D-NCSX-FPA-001**

**Table 7 - Stud Installation Data (continued)**

<b>STUD</b>	<b>STUD LOCATED</b>	<b>STUD PLACED</b>	<b>STUD TORQUED</b>	<b>STUD RE-TORQUED</b>	<b>STUD MEASURED</b>	<b>INSPECTION</b>	<b>COMMENTS</b>
BK-8							
BK-9							
BK-10							
BK-11							
BK-12							
BK-13							
BK-14							
BK-15							
BK-16							
BK-17							
BK-18							
BK-19							
BK-20							
BK-21							
BK-22							
BK-23							
BK-24							
BK-25							
BK-26							
BK-27							
BK-28							

**Field Period Assembly Station One  
D-NCSX-FPA-001**

**Table 7 - Stud Installation Data (continued)**

<b>STUD</b>	<b>STUD LOCATED</b>	<b>STUD PLACED</b>	<b>STUD TORQUED</b>	<b>STUD RE-TORQUED</b>	<b>STUD MEASURED</b>	<b>INSPECTION</b>	<b>COMMENTS</b>
Bk-29							
BK-31							
BK-32							
BK-33							
BL-1							
BL-2							
BL-3							
BL-4							
BL-5							
BL-6							
BL-7							
BL-8							
BL-9							
BL-10							
BL-11							
BL-12							
BL-13							
BL-14							
BL-15							
BL-16							

**Field Period Assembly Station One  
D-NCSX-FPA-001**

**Table 7 - Stud Installation Data (continued)**

<b>STUD</b>	<b>STUD LOCATED</b>	<b>STUD PLACED</b>	<b>STUD TORQUED</b>	<b>STUD RE-TORQUED</b>	<b>STUD MEASURED</b>	<b>INSPECTION</b>	<b>COMMENTS</b>
BL-17							
BL-18							
BL-19							
BL-20							
BL-21							
BL-22							
BL-23							
BL-24							
BL-25							
BL-26							
BL-27							
BL-28							
BL-29							
BL-30							
BL-31							
BL-32							
BL-33							
BL-34							
BM-1							
BM-2							
BM-3							



**Field Period Assembly Station One  
D-NCSX-FPA-001**

**Table 7 - Stud Installation Data (continued)**

<b>STUD</b>	<b>STUD LOCATED</b>	<b>STUD PLACED</b>	<b>STUD TORQUED</b>	<b>STUD RE-TORQUED</b>	<b>STUD MEASURED</b>	<b>INSPECTION</b>	<b>COMMENTS</b>
BM-4							
BM-5							
BM-6							
BM-7							
BM-8							
BM-9							
BM-10							
BM-11							
BM-12							
BM-13							
BM-14							
BM-15							
BM-16							
BM-17							
BM-18							
BM-19							
BM-20							
BM-21							
BM-22							
BM-23							
BM-24							

**Field Period Assembly Station One  
D-NCSX-FPA-001**

**Table 7 - Stud Installation Data (continued)**

<b>STUD</b>	<b>STUD LOCATED</b>	<b>STUD PLACED</b>	<b>STUD TORQUED</b>	<b>STUD RE-TORQUED</b>	<b>STUD MEASURED</b>	<b>INSPECTION</b>	<b>COMMENTS</b>
BN-1							
BN-2							
BN-3							
BN-4							
BN-5							
BN-6							
BN-7							
BN-8							
BN-9							
BN-10							
BN-11							
BN-12							
BN-13							
BN-14							
BN-15							
BN-16							
BN-17							
BN-18							
BN-19							
BN-20							

**Field Period Assembly Station One  
D-NCSX-FPA-001**

**Table 7 - Stud Installation Data (continued)**

<b>STUD</b>	<b>STUD LOCATED</b>	<b>STUD PLACED</b>	<b>STUD TORQUED</b>	<b>STUD RE-TORQUED</b>	<b>STUD MEASURED</b>	<b>INSPECTION</b>	<b>COMMENTS</b>
BN-21							
BN-22							
BP-1							
BP-2							
BP-3							
BP-4							
BP-5							
BP-6							
BP-7							
BP-8							
BP-9							
BP-10							
BP-11							
BP-12							
BP-13							
BP-14							
BP-15							
BP-16							
BP-17							
BP-18							

**Field Period Assembly Station One  
D-NCSX-FPA-001**

**Table 7 - Stud Installation Data (continued)**

<b>STUD</b>	<b>STUD LOCATED</b>	<b>STUD PLACED</b>	<b>STUD TORQUED</b>	<b>STUD RE-TORQUED</b>	<b>STUD MEASURED</b>	<b>INSPECTION</b>	<b>COMMENTS</b>
BP-19							
BP-20							
BP-21							
BQ-1							
BQ-2							
BQ-3							
BQ-4							
BQ-5							
BQ-6							
BQ-7							
BQ-8							
BQ-9							
BQ-10							
BQ-11							
BQ-12							
BQ-13							
BQ-14							
BQ-15							
BQ-16							
BQ-17							

**Field Period Assembly Station One  
D-NCSX-FPA-001**

**Table 7 - Stud Installation Data (continued)**

<b>STUD</b>	<b>STUD LOCATED</b>	<b>STUD PLACED</b>	<b>STUD TORQUED</b>	<b>STUD RE-TORQUED</b>	<b>STUD MEASURED</b>	<b>INSPECTION</b>	<b>COMMENTS</b>
BQ-18							
BQ-19							
BQ-20							
BR-1							
BR-2							
BR-3							
BR-4							
BR-5							
BR-6							
BR-7							
BR-8							
BR-9							
BR-10							
BR-11							
BR-12							
BR-13							
BR-14							
BR-15							
BR-16							
BR-17							

**Field Period Assembly Station One  
D-NCSX-FPA-001**

**Table 7 - Stud Installation Data (continued)**

<b>STUD</b>	<b>STUD LOCATED</b>	<b>STUD PLACED</b>	<b>STUD TORQUED</b>	<b>STUD RE-TORQUED</b>	<b>STUD MEASURED</b>	<b>INSPECTION</b>	<b>COMMENTS</b>
BR-18							
BR-19							

**Field Period Assembly Station One  
D-NCSX-FPA-001**

**Table 8 - H/C Lines Installation and Leak Check Data**

<b>H/CLINE</b>	<b>FLEX LINE INSTALLED</b>	<b>HARD LINE INSTALLED</b>	<b>JOINT BRAZED</b>	<b>LEAK CHECKED</b>	<b>FLOW CHECKED</b>	<b>COMMENTS</b>
AA-1						
AA-2						
AB-1						
AB-2						
AC-1						
AC-2						
AD-1						
AD-2						
AE-1						
AE-2						
AF-1						
AF-2						
AG-1						
AG-2						
AH-1						
AH-2						
AJ-1						
AJ-2						
AK-1						
AK-2						
AL-1						

**Field Period Assembly Station One  
D-NCSX-FPA-001**

**Table 8 - H/C Lines Installation and Leak Check Data (continued)**

<b>H/CLINE</b>	<b>FLEX LINE INSTALLED</b>	<b>HARD LINE INSTALLED</b>	<b>JOINT BRAZED</b>	<b>LEAK CHECKED</b>	<b>FLOW CHECKED</b>	<b>COMMENTS</b>
AL-2						
AM-1						
AM-2						
AN-1						
AN-2						
AP-1						
AP-2						
AQ-1						
AQ-2						
AR-1						
AR-2						
BA-1						
BA-2						
BB-1						
BB-2						
BC-1						
BC-2						
BD-1						
BD-2						
BE-1						



**Field Period Assembly Station One  
D-NCSX-FPA-001**

**Table 8 - Table H/C/ Lines Installation and Leak Check Data (continued)**

<b>H/CLINE</b>	<b>FLEX LINE INSTALLED</b>	<b>HARD LINE INSTALLED</b>	<b>JOINT BRAZED</b>	<b>LEAK CHECKED</b>	<b>FLOW CHECKED</b>	<b>COMMENTS</b>
BE-2						
BF-1						
BF-2						
BG-1						
BG-2						
BH-1						
BH-2						
BJ-1						
BJ-2						
BK-1						
BK-2						
BL-1						
BL-2						
BM-1						
BM-2						
BN-1						
BN-2						
BP-1						
BP-2						
BQ-1						
BQ-2						

**Field Period Assembly Station One  
D-NCSX-FPA-001**

**Table 8 - Table H/C/ Lines Installation and Leak Check Data (continued)**

<b>H/CLINE</b>	<b>FLEX LINE INSTALLED</b>	<b>HARD LINE INSTALLED</b>	<b>JOINT BRAZED</b>	<b>LEAK CHECKED</b>	<b>FLOW CHECKED</b>	<b>COMMENTS</b>
BR-1						
BR-2						