NCSX

WBS – 1 Stellarator Core

Cost and schedule status

Engineering Meeting

December 13, 2000

B. Nelson, M. Cole, P. Goranson, D. Williamson

Presentation Outline

- **What is the plan?**
- **Where are we for the Stellarator Core ?**
- **What are key issues / “holes” ?**

Plan A (P. Heitzenroeder, 12/8)

- **By February, *for each WBS 1 element*:**
 - Define the current requirements;
 - Develop a technical basis (design concept)
 - Develop a schedule (in project format)
 - Develop a cost estimate in FY 2001 \$. (in project format)
 - Identify opportunities for reducing costs by deferring items to operation or upgrades
 - Identify cost drivers and tradeoffs which have potential for cost reductions
 - Identify major interfaces between other work elements.

WBS - 1, Stellarator Core

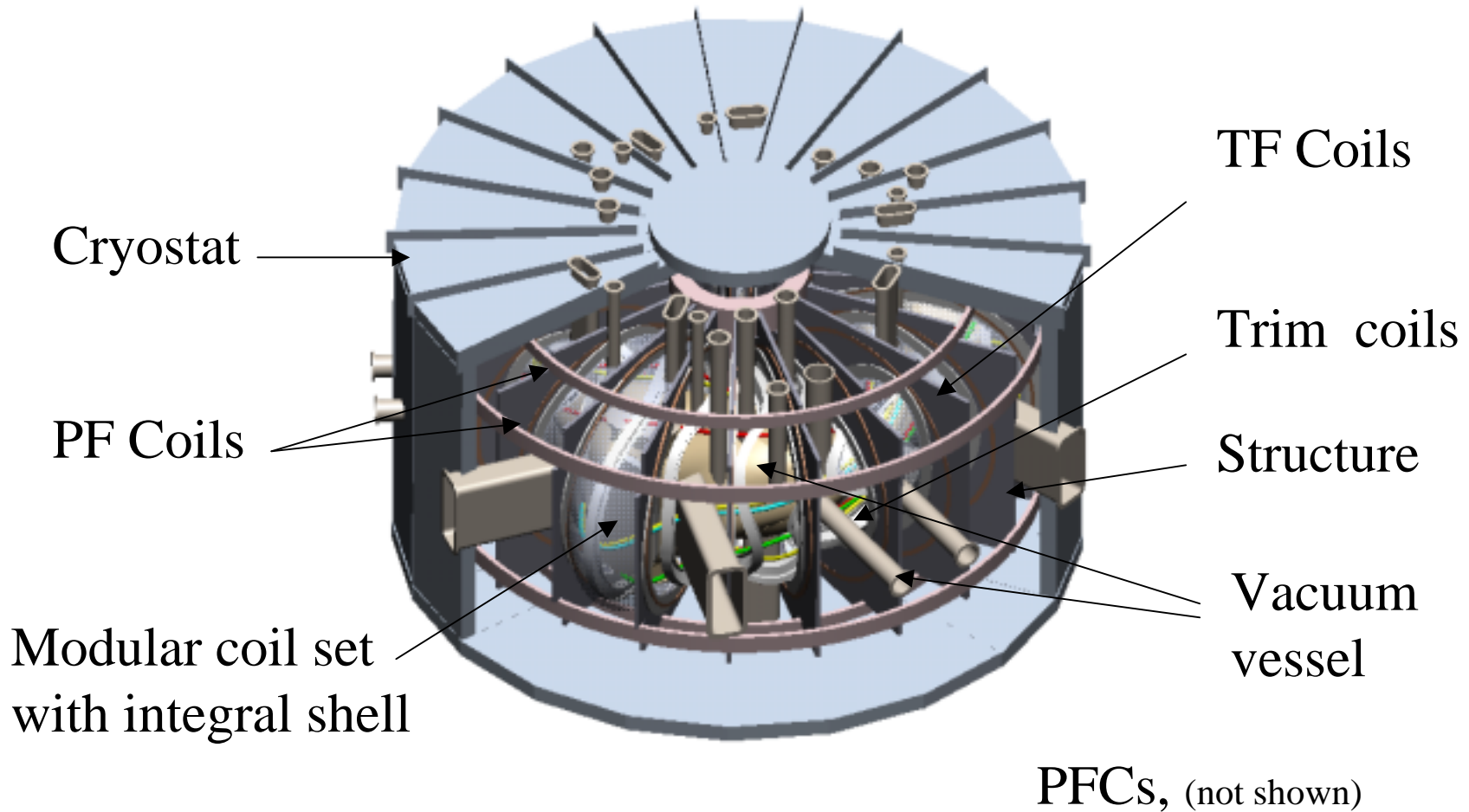

WBS 1.1 PFCs, requirements

- **Basic requirements**
 - **Carbon based, bakeable to 350C**
 - **NBI armor, limiters needed day 1**
 - **6 MW for 0.5 s**
 - **2 cm from plasma inboard, 10 cm outboard**
 - **Accomodate invessel sensors, mag loops, etc.**

- **Upgrade requirements**
 - **Full coverage of surfaces with carbon**
 - **12 MW for 1.7 s**
 - **Provision for divertor**

WBS 1.1 PFCs, design concept

- **Two options for FW/NBI armor**
 - Individual tiles in selected spots
 - Full coverage with large, formed panels
- **Inertial cooling during shot, conduction cooling to vessel between shots**
- **Boronization, GDC assumed in all cases**
- **Limiters, divertor baffles still being defined**

PFC locations

- OB limiters = $.25 \text{ m}^2$ each
- IB limiters = $.2 \text{ m}^2$ each
- NBI armor = 1 m^2 each
- Divertor baffles = $.85 \text{ m}^2$ each

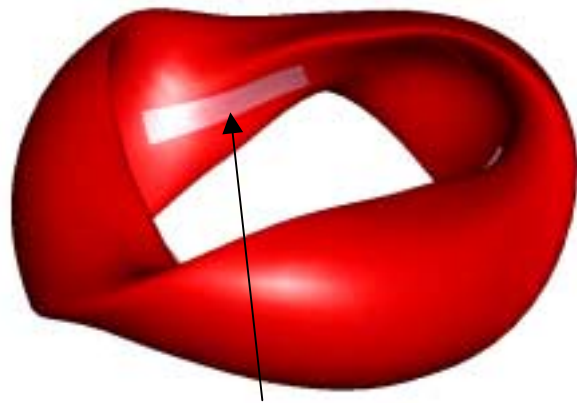

Inboard limiter
Typ 3 places

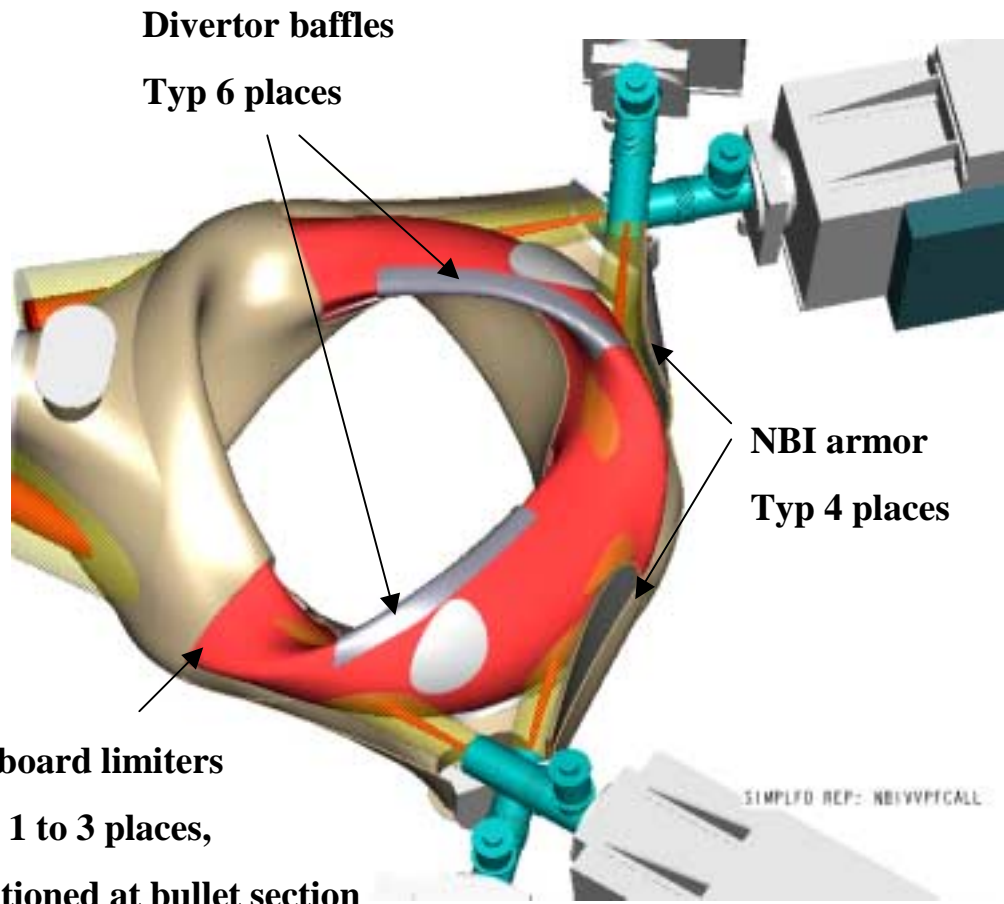

WBS 1.1 PFCs , 1.2 VV cost est.

WBS Element & Description	Design (FY-99K\$)	R&D (FY-99K\$)	Material, Hardware, Procurements (FY-99K\$)	Fabrication and Assembly (FY-99K\$)	Installation & Testing (FY-99K\$)	Subtotal (w/o Contingency) - No Conceptual Design (FY-99K\$)	Percent Contingency	Contingency (FY-99K\$)	Totals (w/ Contingency BUT NO Conceptual Design) (FY-99K\$)
110 Plasma Facing Components	\$482.0K	\$0.0K	\$620.8K	\$16.6K	\$0.0K	\$1,119.3K		\$358.2K	\$1,477.5K
111 First Wall	\$440.0K	\$0.0K	\$0.0K	\$0.0K	\$0.0K	\$440.0K	32%	\$140.8K	\$580.8K
112 Divertor	\$0.0K	\$0.0K	\$0.0K	\$0.0K	\$0.0K	\$0.0K	32%	\$0.0K	\$0.0K
113 NBI armor	\$17.0K	\$0.0K	\$444.1K	\$0.0K	\$0.0K	\$461.1K	32%	\$147.6K	\$608.7K
114 <i>not used</i>	\$0.0K	\$0.0K	\$0.0K	\$0.0K	\$0.0K	\$0.0K	32%	\$0.0K	\$0.0K
115 Limiters	\$25.0K	\$0.0K	\$174.1K	\$0.0K	\$0.0K	\$199.1K	32%	\$63.7K	\$262.8K
116 Wall Conditioning Systems	<i>\$0.0K</i>	<i>\$0.0K</i>	<i>\$2.6K</i>	<i>\$16.6K</i>	<i>\$0.0K</i>	<i>\$19.1K</i>	32%	<i>\$6.1K</i>	<i>\$25.2K</i>
116 Glow Discharge Subsystem Boronizing Startup and Testing	\$0.0K	\$0.0K	\$0.0K	\$1.8K	\$0.0K	\$1.8K	32%	\$0.6K	\$2.4K
116 Subsystem PFC Cooling System (Inside	\$0.0K	\$0.0K	\$2.6K	\$14.7K	\$0.0K	\$17.3K	32%	\$5.5K	\$22.8K
117 Cryostat)	\$0.0K	\$0.0K	\$0.0K	\$0.0K	\$0.0K	\$0.0K	32%	\$0.0K	\$0.0K
118 PFC Local I&C	\$0.0K	\$0.0K	\$0.0K	\$0.0K	\$0.0K	\$0.0K	32%	\$0.0K	\$0.0K
120 Vacuum Vessel	\$352.0K	\$150.0K	\$1,211.9K	\$403.1K	\$727.9K	\$2,844.9K		\$1,536.2K	\$4,381.1K
121 VV shell	\$242.0K	\$150.0K	\$938.8K	\$0.0K	\$727.9K	\$2,058.7K	54%	\$1,111.7K	\$3,170.3K
122 VV Ports & Extensions	\$66.0K	\$0.0K	\$82.7K	\$155.2K	\$0.0K	\$303.9K	54%	\$164.1K	\$468.0K
123 PFC interface	\$8.0K	\$0.0K	\$134.6K	\$124.8K	\$0.0K	\$267.4K	54%	\$144.4K	\$411.9K
124 <i>not used</i>									
125 <i>not used</i> VV Heating and Cooling System									
126 (inside Cryostat)	\$20.0K	\$0.0K	\$12.0K	\$123.1K	\$0.0K	\$155.1K	54%	\$83.7K	\$238.8K
127 VV Supports	\$16.0K	\$0.0K	\$43.9K	\$0.0K	\$0.0K	\$59.9K	54%	\$32.3K	\$92.2K
128 VV Local I&C	\$0.0K	\$0.0K	\$0.0K	\$0.0K	\$0.0K	\$0.0K	54%	\$0.0K	\$0.0K

PFC Cost est. plan

- **Develop “generic” solutions for first wall coverage, limiters, divertor baffles**
- **Refine cost estimate based on recent experience, eg, NSTX**
- **Obtain vendor ROM quote for formed panels (BF Goodrich Aerospace)**

WBS 1.2 Vacuum vessel

- **Vessel must be bakeable to 350 C**
- **Low permeability (< 1.02 nominal goal)**
- **Provide support for internal components**
- **Access ports for diagnostics, vacuum pumping, heating systems, and manned access**

Vacuum Vessel

- **Shell material** Inconel 625
- **Thickness** .375 inch
- **Wt of shell** 9700 lbs
- **Total wt w/ports** ~ 15000lbs
- **Internal shell area** ~ 50 m²
- **Internal shell volume** ~ 13 m³
- **All metal seals**
- **Combination microtherm and solomide foam insulation**

- **Est. heat load on cold structures:**
 - **Bakeout** 30 kW
 - **Operation** 20 kW

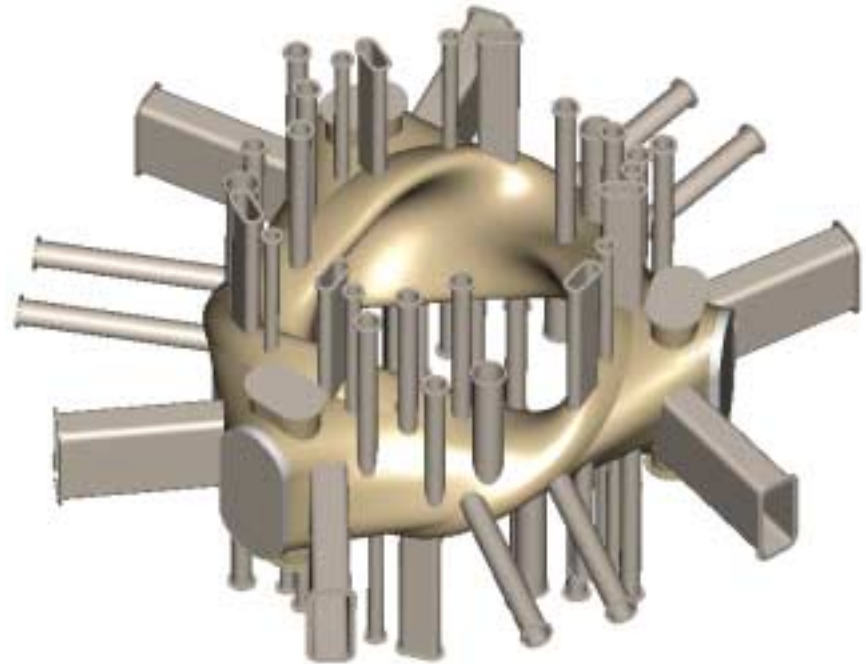

WBS 1.2 Vacuum Vessel

- **Vessel half period assembled from minimum of four different pressings, may need more**

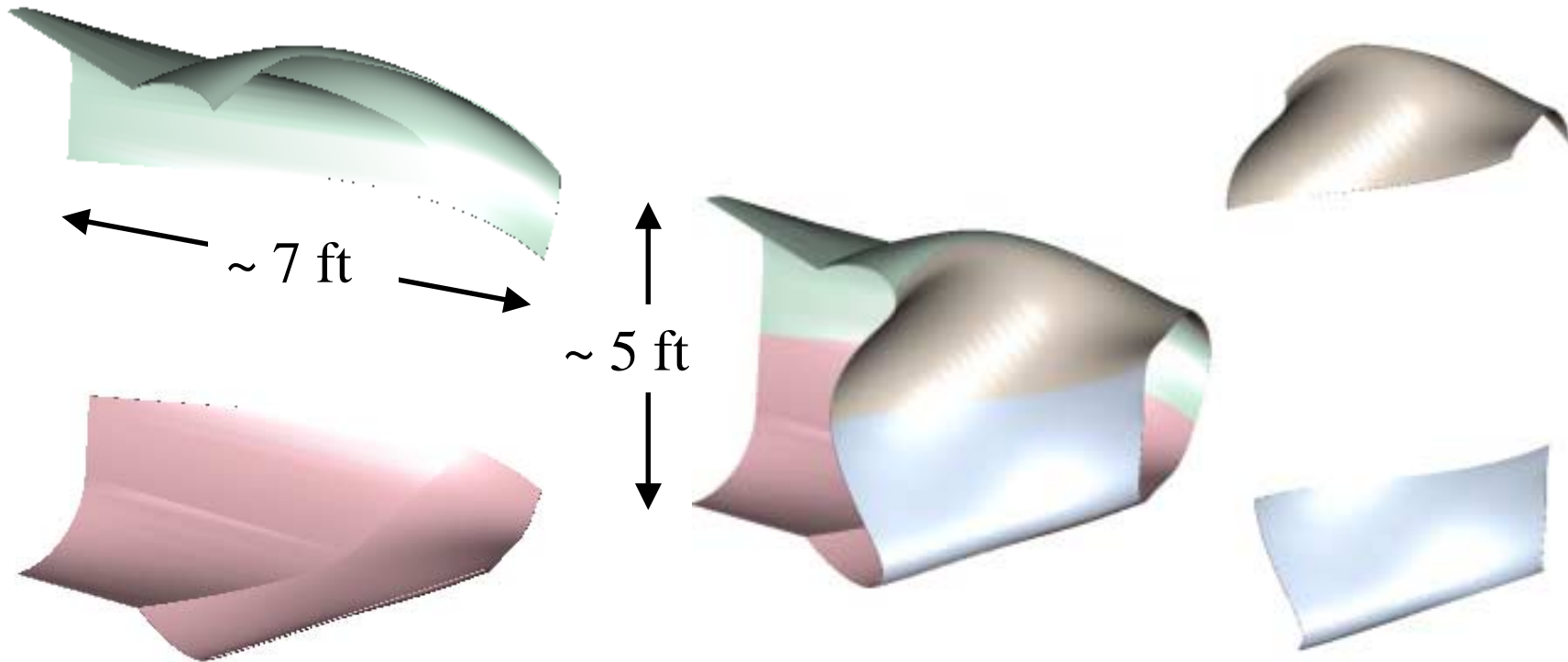

WBS 1.2 Vacuum Vessel ports

- Port geometry still being defined
- Location of flange interface on port extension depends on use

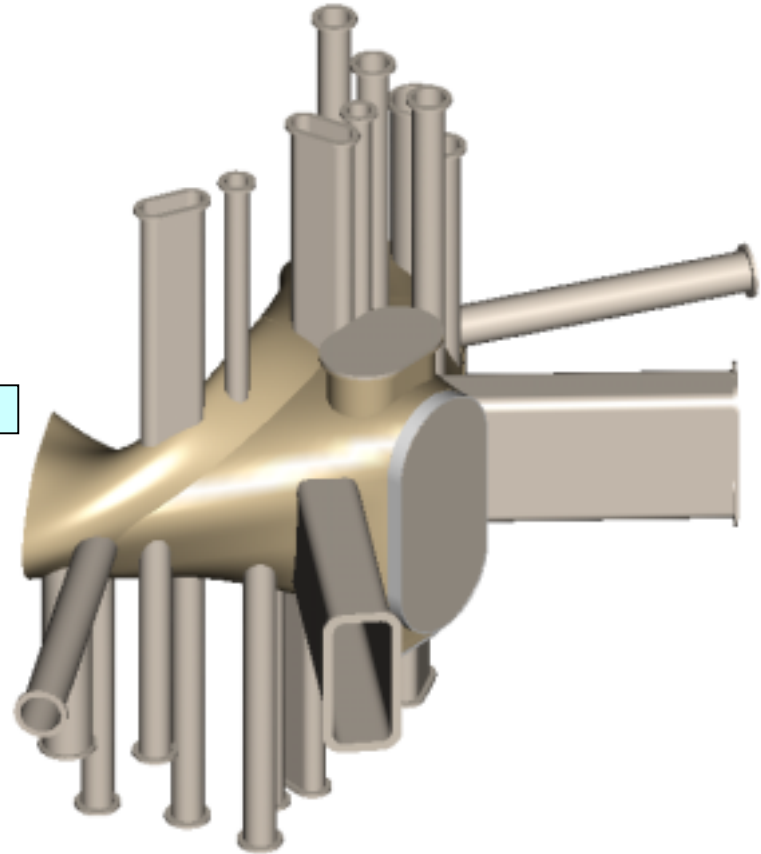
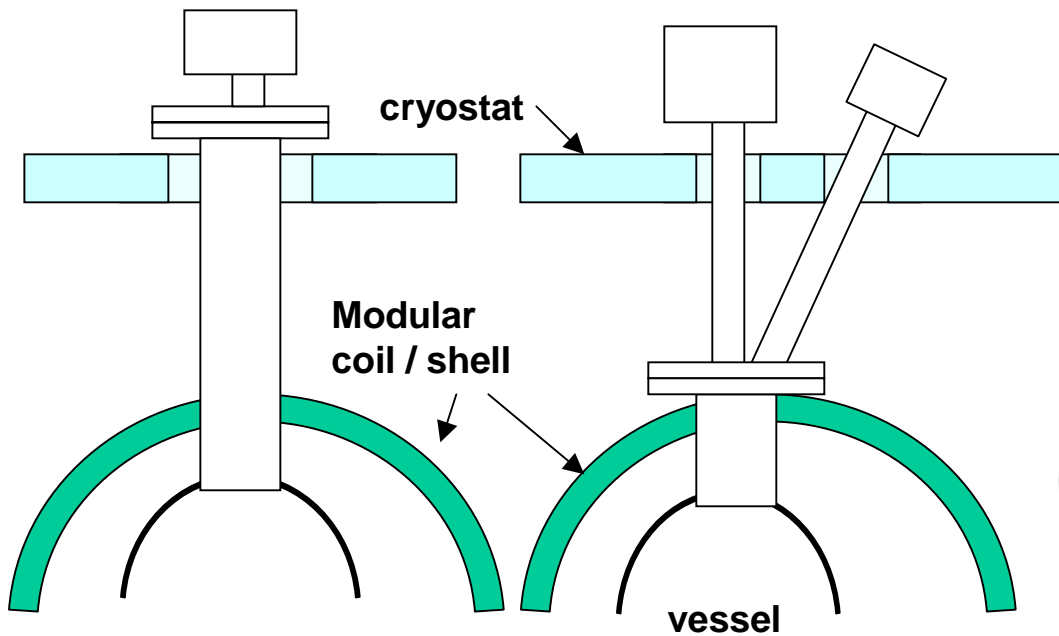

WBS 1.3 TF Coils

- 21 coils providing +/- 0.25 T
- Coils are split and mount to radial support plates
- Coils wound from hollow copper conductor
- 6 turns per coil, 3 on each side of plate

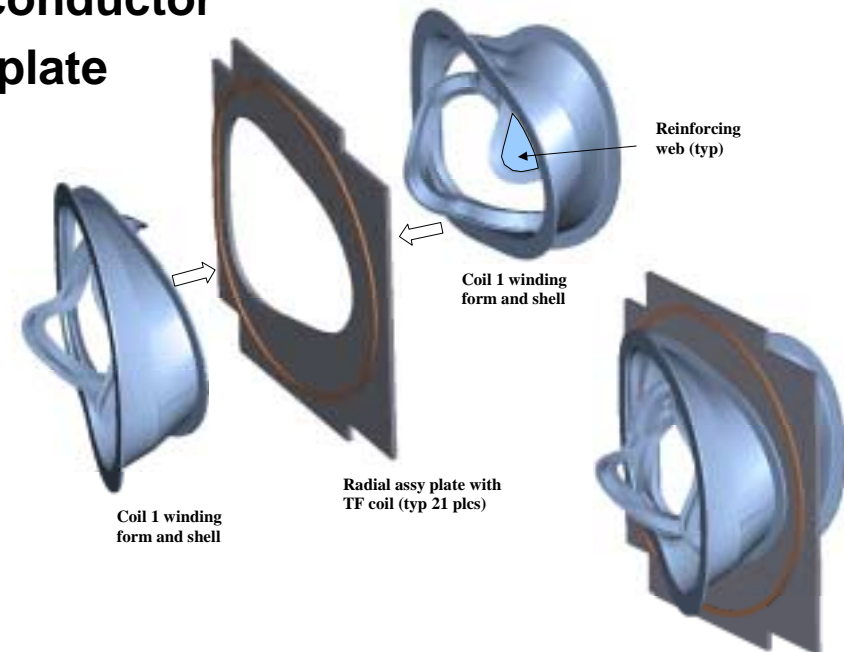
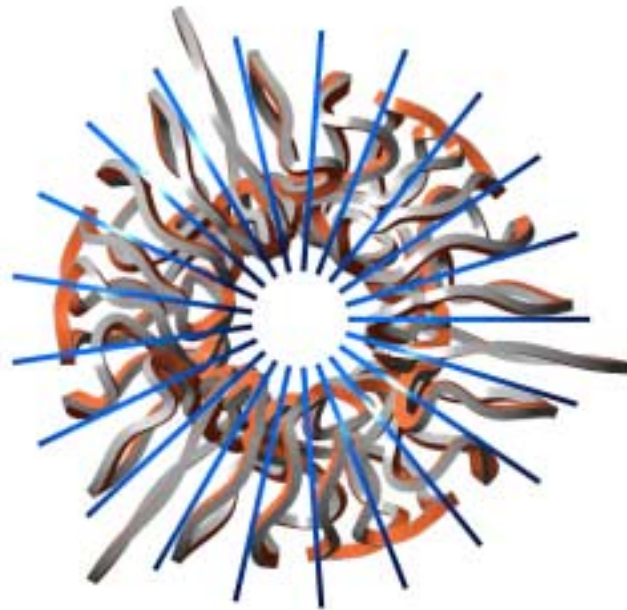

TF Coils

- **Spreadsheet / algorithm**
 - **Engr based on # drawings, specs, analysis**
 - **Coils include matl, forming, insulating**
 - **Bus inside cryostat based on same proportion as PBX bus**
 - **Estimate must be redone**
- **Plan**
 - **Prepare est. package with cross sections, dimensions**
 - **Contact coil vendor, eg Everson, and/or AES for ROM estimate**

WBS 1.4 PF Coils

- **5 pairs of PF coils required for equilibrium, OH and field shaping functions**
- **Field errors**
- **OH supplies minimum of 1, goal of 3 V-s**
- **Located outside modular and TF coils**
- **Wound from hollow copper conductor, and vacuum impregnated with epoxy**
- **Operate at cryogenic temperature**
- **Free-standing between supports**
- **Separate leads for each coil**

PF Coil Locations

- Coils supported by radial support plates

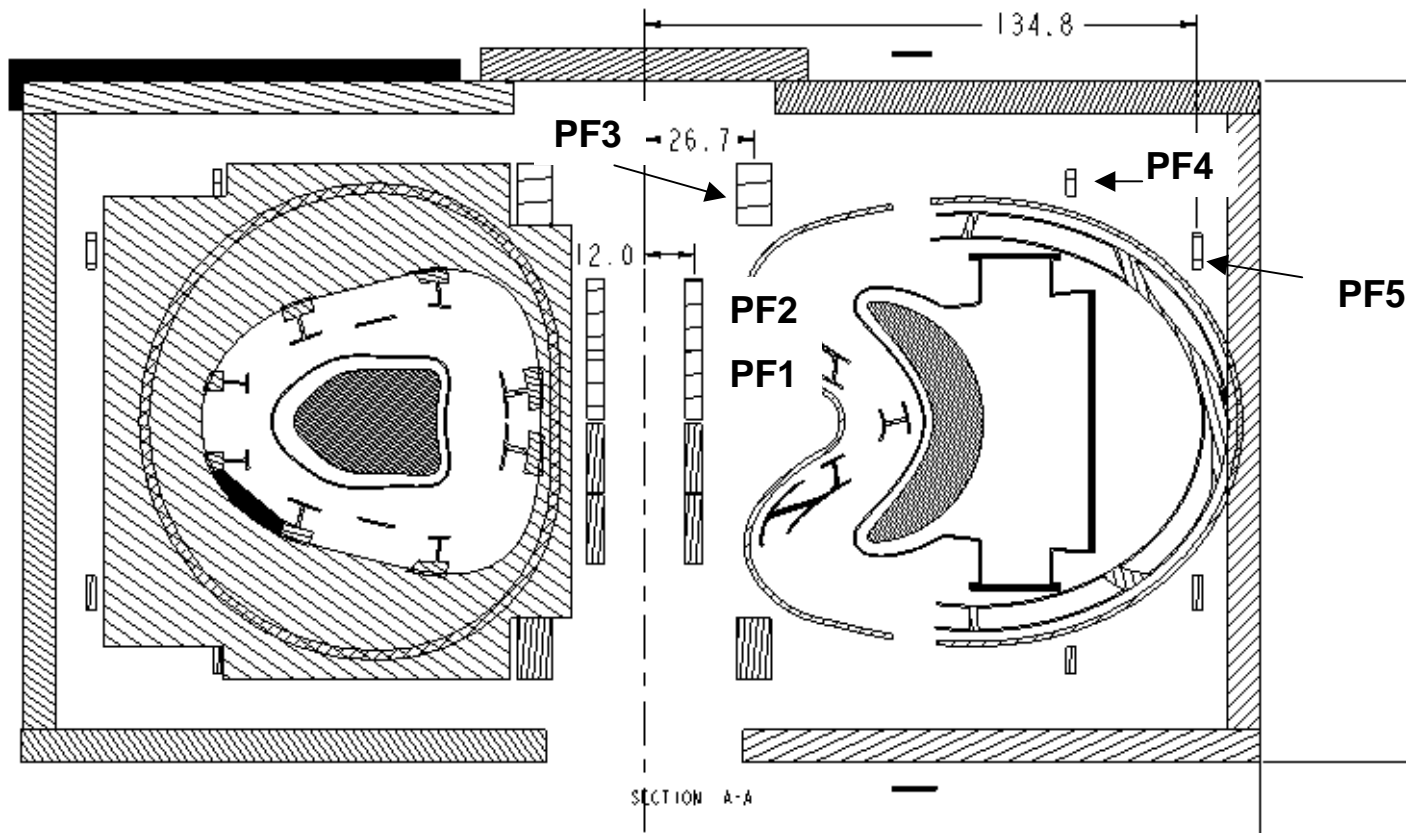

PF Coil cost

- **Spreadsheet / algorithm**
 - Engr based on # drawings, specs, analysis
 - Coils include matl and nominal \$30/lb for fab
 - Bus inside cryostat at \$75/m plus clamps, lead blocks; routing/inspection 100 hrs/coil
- **Plan**
 - Prepare est. package with cross sections, dimensions
 - Contact coil vendor, eg Everson, and/or AES for ROM estimate
 - Re-look at using salvaged coils

PF / TF Coil est. from spreadsheet

WBS Element & Description	Design (FY-99K\$)	R&D (FY-99K\$)	Material, Hardware, Procurements (FY-99K\$)	Fabrication and Assembly (FY-99K\$)	Installation & Testing (FY-99K\$)	Subtotal (w/o Contingency) - No Conceptual Design (FY-99K\$)	Percent Contingency	Contingency (FY-99K\$)	Totals (w/ Contingency BUT NO Conceptual Design) (FY-99K\$)
130 TF Coils (background coils)	\$464.0K	\$0.0K	\$1,360.7K	\$60.9K	\$0.0K	\$1,885.6K		\$528.0K	\$2,413.6K
131 TF Winding Pack	\$0.0K	\$0.0K	\$1,128.5K	\$0.0K	\$0.0K	\$1,128.5K	28%	\$316.0K	\$1,444.5K
132 TF Cases	\$0.0K	\$0.0K	\$154.0K	\$0.0K	\$0.0K	\$154.0K	28%	\$43.1K	\$197.2K
133 TF Assembly	\$464.0K	\$0.0K	\$65.5K	\$0.0K	\$0.0K	\$529.5K	28%	\$148.3K	\$677.8K
TF Power and Cooling Interfaces									
134 (leads)	\$0.0K	\$0.0K	\$12.6K	\$60.9K	\$0.0K	\$73.5K	28%	\$20.6K	\$94.1K
140 PF Coils (VF, EQ. OH)	\$390.8K	\$0.0K	\$705.7K	\$0.0K	\$59.0K	\$1,155.5K		\$323.5K	\$1,479.0K
141 PF - OH Solenoid	\$202.0K	\$0.0K	\$72.4K	\$0.0K	\$23.0K	\$297.4K	28%	\$83.3K	\$380.7K
142 PF - Ring Magnets	\$188.8K	\$0.0K	\$633.3K	\$0.0K	\$36.0K	\$858.1K	28%	\$240.3K	\$1,098.4K
142 Refurbish existing coils	\$0.0K	\$0.0K	\$0.0K	\$0.0K	\$0.0K	\$0.0K	28%	\$0.0K	\$0.0K
142 New coils	\$188.8K	\$0.0K	\$633.3K	\$0.0K	\$36.0K	\$858.1K	28%	\$240.3K	\$1,098.4K
PF power and cooling interfaces									
143 (leads)	\$0.0K	\$0.0K	\$20.9K	\$108.2K	\$119.3K	\$248.4K	28%	\$69.6K	\$318.0K

WBS 1.5 Cryostat

- **Cryostat needed for cryo-cooled coil set**
- **Cryostat must be sealed with slight positive pressure to prevent air ingress, condensation on coils**
- **Exterior of cryostat may require forced air, heaters or other means of preventing dew on exterior surfaces**
- **Cryostat must provide means for maintenance, diagnostic access**
- **Consistent with flammability req.**

Cryostat

- **Frame and panel construction similar to FIRE design**
- **Gortiflex boots to seal between vessel port extensions and cryostat**
- **Area = 200 m²**
- **Volume = 190 m³**
- **Thickness = 8 inches**
- **Details TBD**
- **Est. Cost ~ \$1.5 M**

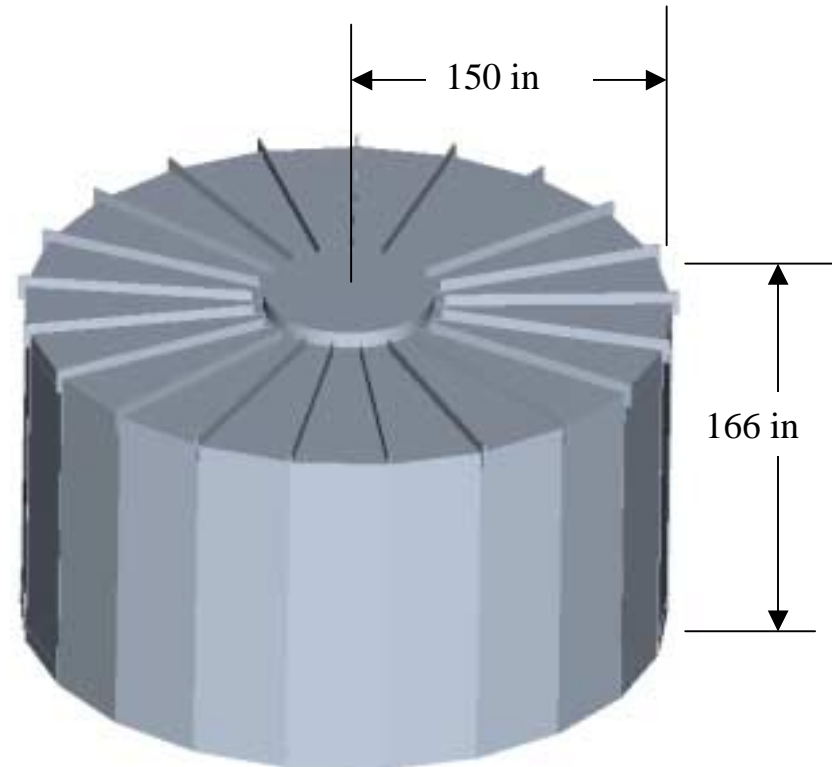

WBS 1.6 Structure

- **Base structure supports stellarator core from foundation**
- **Must provide thermal isolation, seismic restraint, leveling features**
- **Goal is to provide “head clearance” under machine**
- **Design is TBD**
- **Cost bogey is based on TF radial plates, base plate, interfaces with total wt of 46 tons**

WBS 1.7 Modular Coils

- **Basic requirements**
 - **2 Tesla for reference pulse waveform (~ 1 s ESW)**
 - **1 Tesla for 1.5 second flattop, (2+ s ESW)**
 - **+/- 1 mm assumed for winding accuracy**
 - **Coils must provide access for NBI**
 - **Limit conductor current to 24 kA peak**
 - **Peak power limited to ~ 100 MW**
 - **Rep rate goal is 10 minutes**
- **Upgrade requirements**
 - **None identified so far**

Modular Coils

- **Case li383-1017**
- **21 coils, 3 field periods**
- **Coils wound with flexible cable conductor into cast-and-machined forms**
- **Symmetry coils pulled radially out 1 m to provide NBI access**

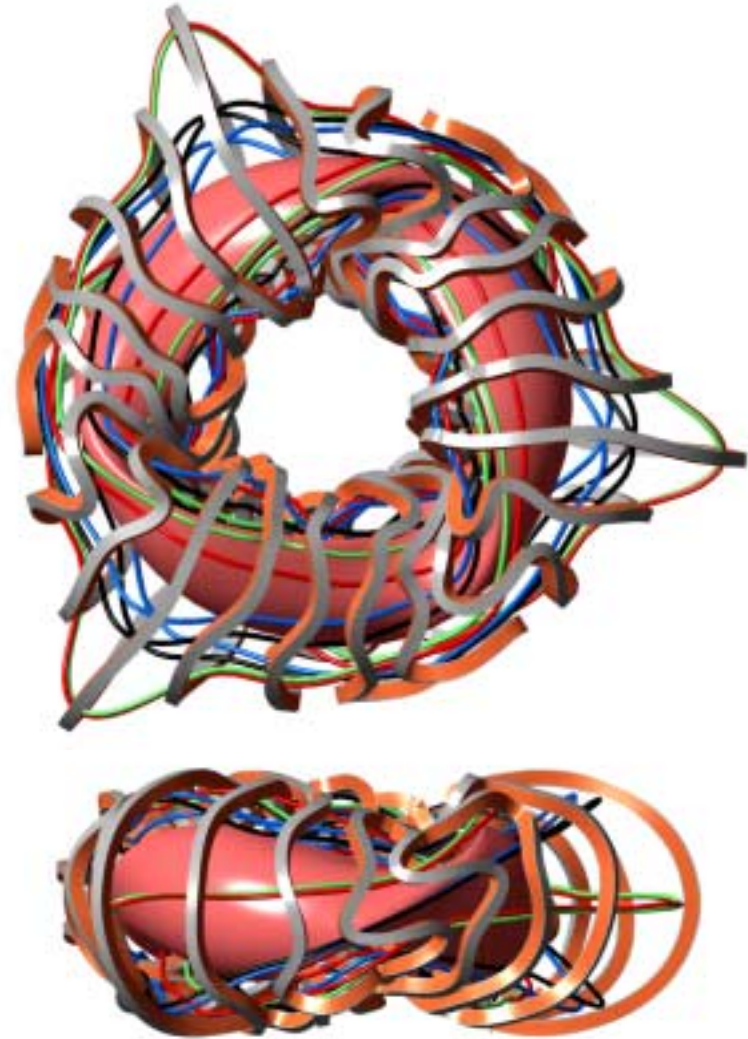

Modular coil winding pack

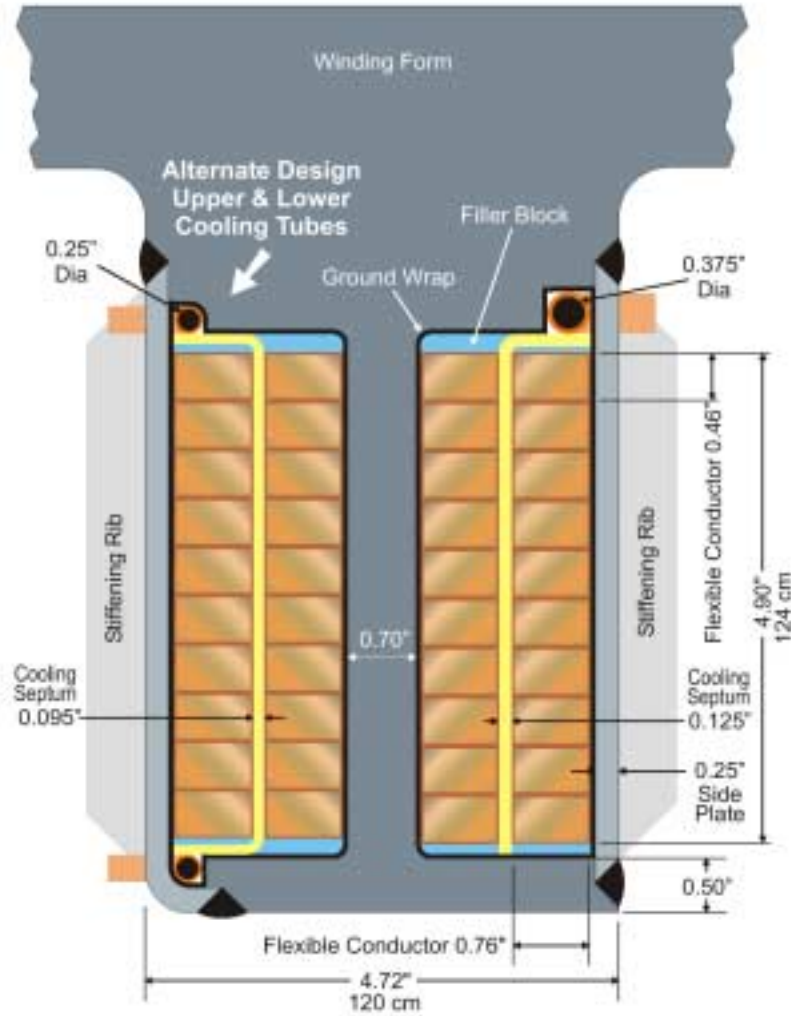

Parameters:

- Coil Envelope = 12 x 16-cm
- Current / Coil = 864-kA @ 2-T
- Number of Turns = 40
- Nominal current / turn = 21.6.-kA
- Conductor weight = 20,600 lbs
- Structure weight = 110,000 lbs
- Total peak power = **70 MW**

Cooling by Conduction to Septum:

- Conductor Size = 19 x 12 mm
- Septum Width = 3-mm
- Cable Packing Factor = 75%
- Net Current Density = **13-kA/cm²**

Modular coil winding process

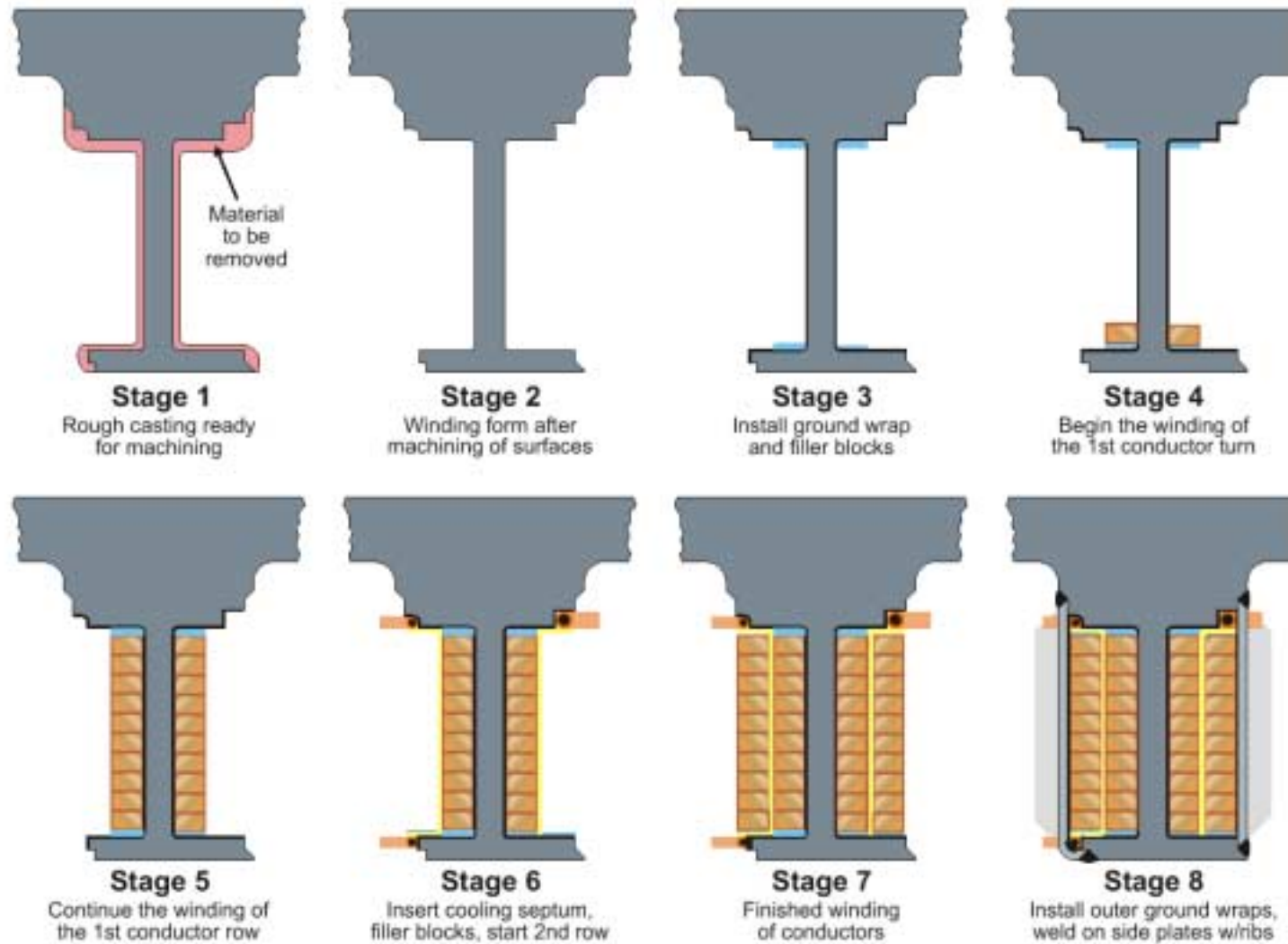

Field period subassembly

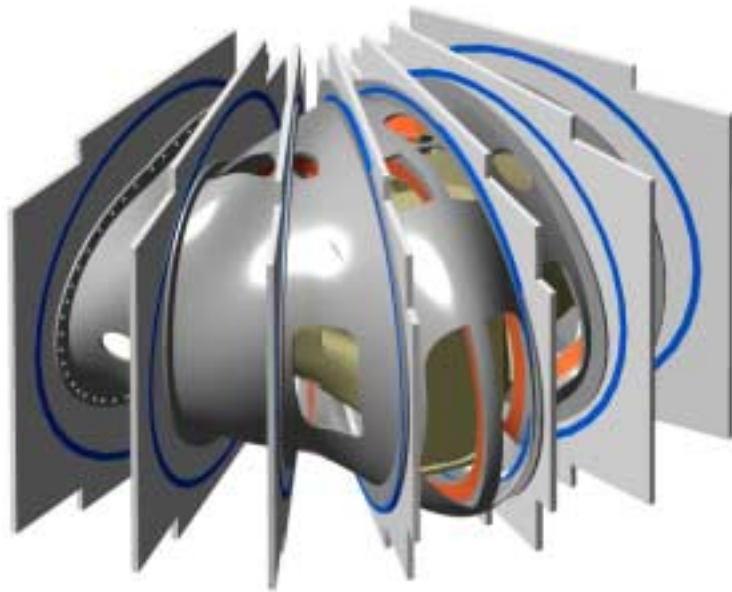

No VV port extensions

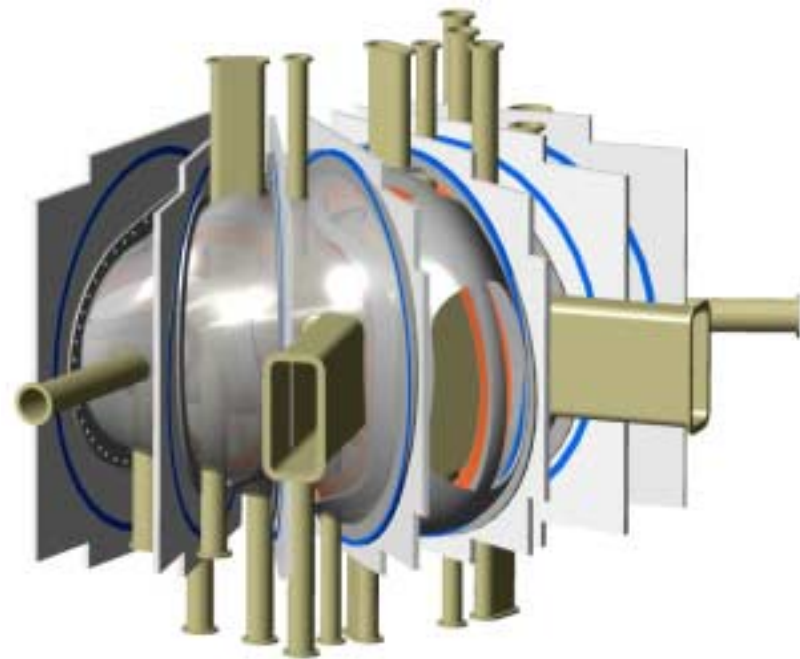

After adding port extensions

Half field period subassembly



Before VV is installed



After VV is installed



Mod coil castings and windings

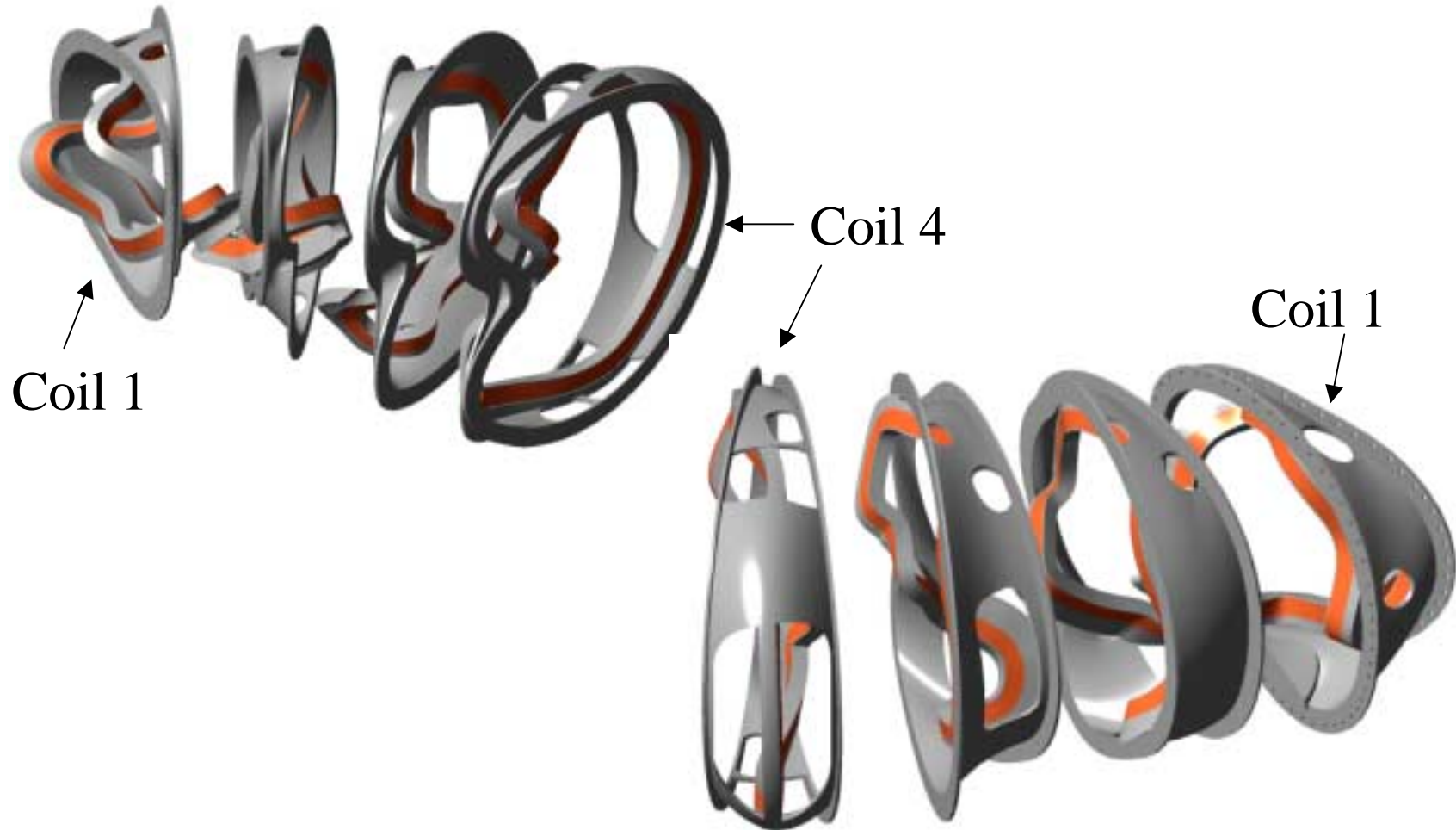

Assembly of 3 field periods

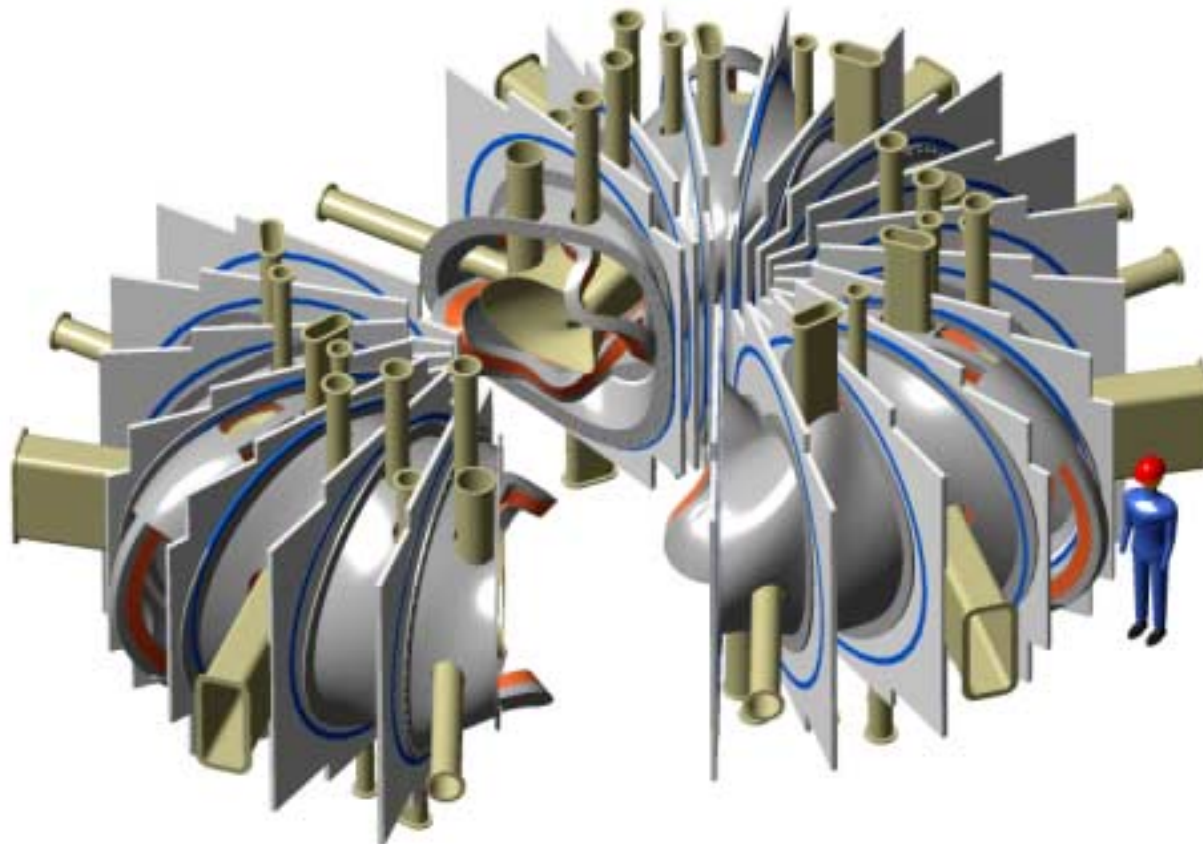

Modular coil set with vac vessel

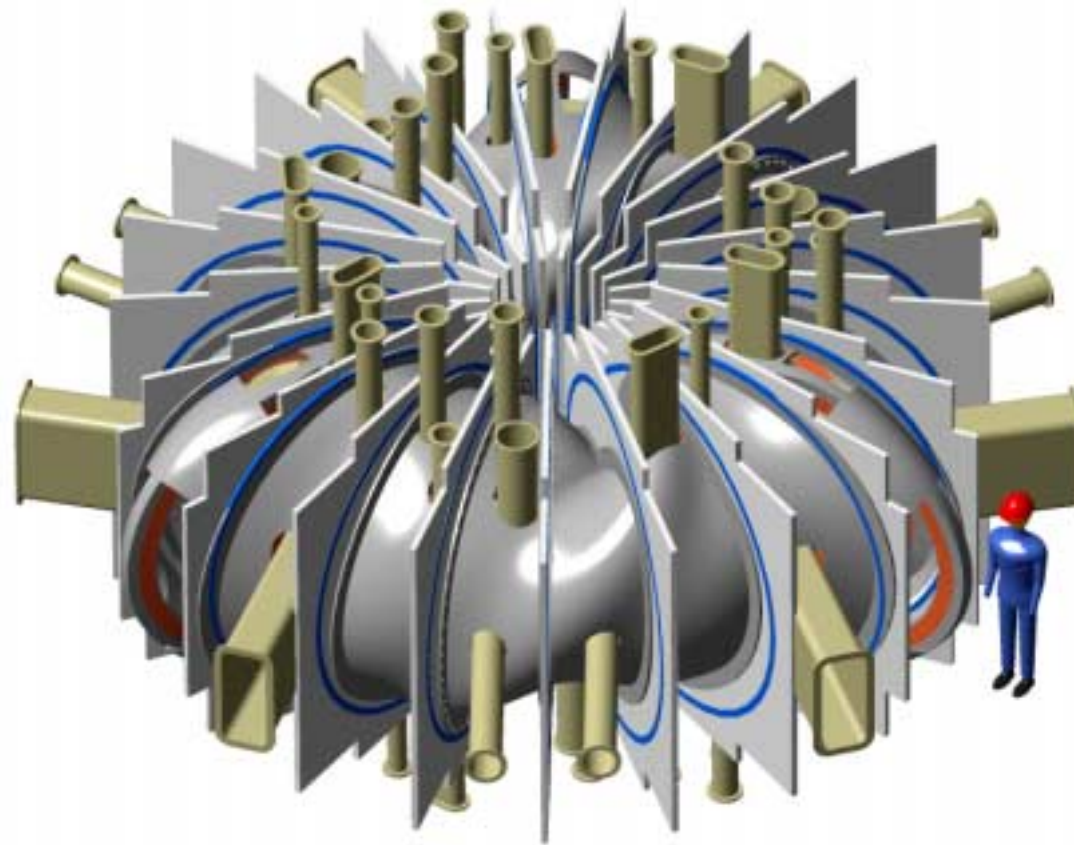

Modular coil cost

- Winding pack based on processes for insulating, winding, potting, etc.
- Coil form based on vendor input for casting, machining, etc.

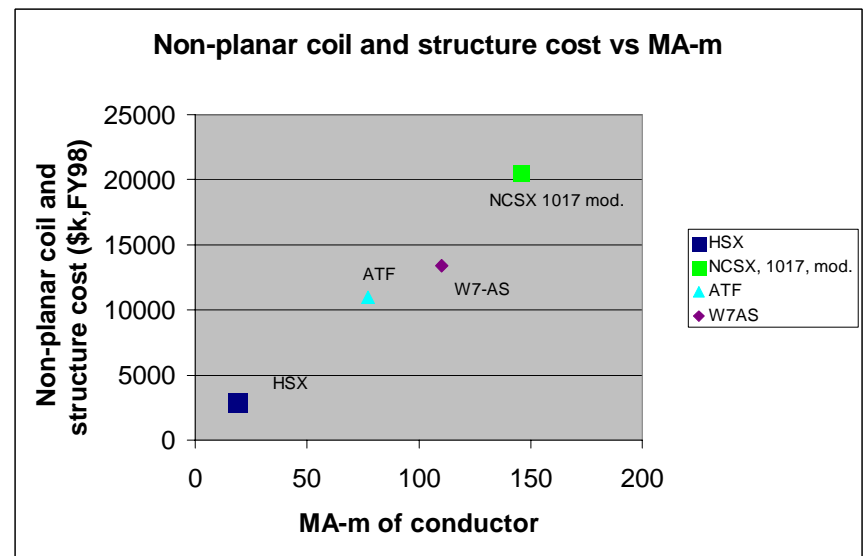
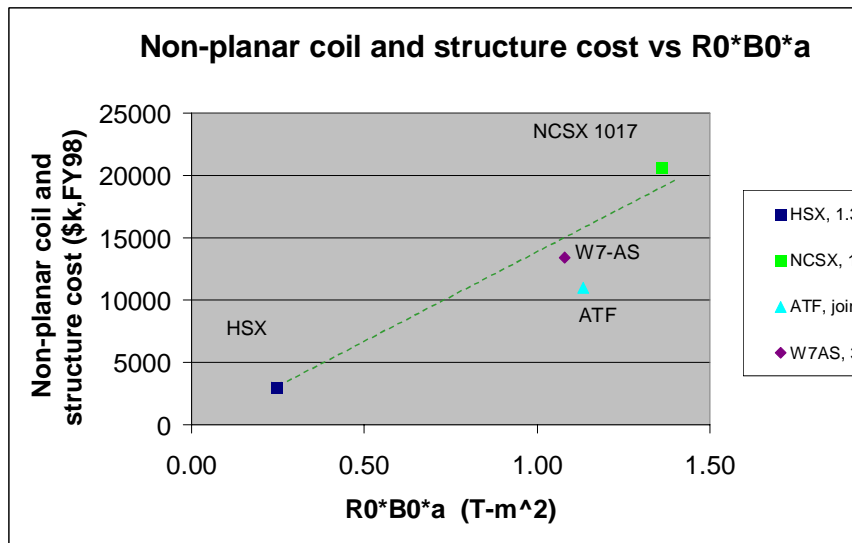

Modular coil cost: spreadsheet

WBS Element & Description	Design (FY-99K\$)	R&D (FY-99K\$)	Material, Hardware, Procurements (FY-99K\$)	Fabrication and Assembly (FY-99K\$)	Installation & Testing (FY-99K\$)	Subtotal (w/o Contingency) - No Conceptual Design (FY-99K\$)	Percent Contingency	Contingency (FY-99K\$)	Totals (w/ Contingency BUT NO Conceptual Design) (FY-99K\$)
170 Modular Coils	\$1,808.0K	\$2,009.1K	\$9,506.9K	\$252.0K	\$142.8K	\$13,718.8K		\$6,859.4K	\$20,578.2K
171 windings	\$0.0K	\$894.9K	\$4,160.9K	\$0.0K	\$0.0K	\$5,055.8K	50%	\$2,527.9K	\$7,583.7K
172 winding form / structure	\$1,808.0K	\$1,114.2K	\$5,304.9K	\$0.0K	\$0.0K	\$8,227.1K	50%	\$4,113.6K	\$12,340.7K
173 leads	\$0.0K	\$0.0K	\$20.4K	\$180.6K	\$71.4K	\$272.4K	50%	\$136.2K	\$408.6K
174 cooling system inside cryostat	\$0.0K	\$0.0K	\$11.2K	\$42.8K	\$14.3K	\$68.3K	50%	\$34.2K	\$102.5K
175 local I&C	\$0.0K	\$0.0K	\$9.5K	\$28.6K	\$57.1K	\$95.1K	50%	\$47.6K	\$142.7K
180 Trim Coils	\$0.0K	\$0.0K	\$0.0K	\$0.0K	\$0.0K	\$0.0K	0%	\$0.0K	\$0.0K

WBS 1.8 Trim Coils

- Trim coils not defined, but helical coils have been modeled
- Tentative location is between vac vessel and modular coils
- Trim coils may be expensive

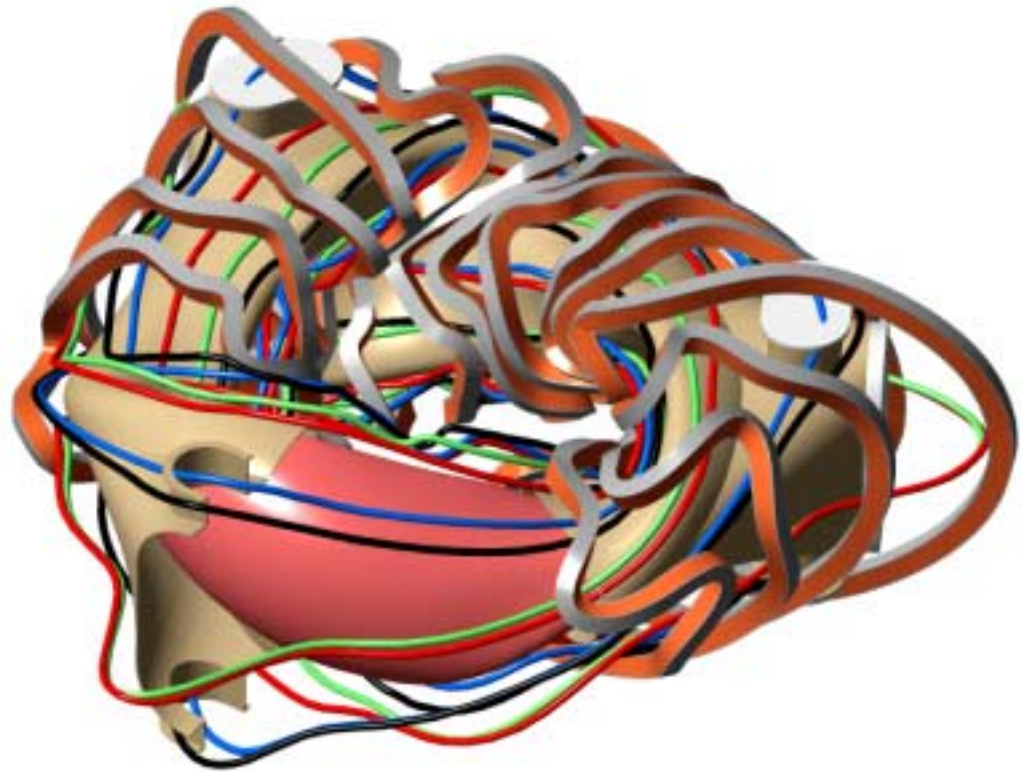

Cost Summary

<u>Elements</u>	Option 2C (FY99\$ k)	Modular Coils, Case li383m_0907, with new TF/PF (\$ k)	delta	Comment
1 Fusion Core Systems	\$12,869	\$34,900	\$21,875	
conceptual design	\$984	\$1,140		30% of design cost
11 - Plasma Facing Components	\$1,925	\$1,478	-\$447	simplified beam armor
12 - Vacuum vessel	\$2,120	\$4,381	\$2,261	more ports added, more detail, bigger
13 - TF (background) Coil Systems	\$26	\$2,414	\$2,387	new TF set for 0.25 T 1/R field
14 - PF Coil Systems	\$0	\$1,479	\$1,479	all new PF/OH system
15 - Cryostat	\$575	\$1,500	\$925	bigger cryostat, cost based on FIRE est.
16 - Machine Structure	\$695	\$1,930	\$1,235	base structure, most cost in mod coil est.
17 - Modular Coils	\$6,544	\$20,578	\$14,034	modular coils provide the primary field
18 - Trim Coils	\$0	\$0		not defined yet
2 - Auxiliary Systems	\$2,293	\$2,288	-\$5	
3 - Diagnostics	\$1,475	\$2,810	\$1,335	revised based on NSTX experience and 25% contingency
4 - Power Systems	\$1,853	\$1,855	\$2	will change as coil configurations are modified
5 - Central I&C and Data Acquisition	\$2,291	\$2,374	\$83	
6 - Site and Facilities	\$7,768	\$6,766	-\$1,002	wall comes down, re-work of facility not included
7 - Machine Assembly	\$4,788	\$4,008	-\$780	PBX not re-used
8 - Project Oversight & Support	\$11,402	\$11,402	\$0	
9 - Pre-Operational Planning & Testing	\$260	\$597	\$337	
Total, with contingency:	\$45,000	\$67,000	\$21,844	
Average Contingency	24%	33%		

Issues / Holes

- **Primary issue: modular coil structure feasibility**
 - CAD / Analysis model
 - Vendor fab advice and ROM cost estimate
- **Next issue: trim coils**
 - Concept TBD
 - Effects on other components TBD
- **Next issue: cryostat**
 - VV interface philosophy
 - Disassembly philosophy
 - Fab concept

Issues / Holes contd.

- **Next issue: base support structure**
 - **Concept TBD**
 - **Cost needs work**

- **Next issue: vacuum vessel ports and access**
 - **PBX vs TFTR beamlines**
 - **Cryostat interfaces**
 - **Length of port extensions**

Near Term Plans

Task	By	Who
Arrange site visits with vendors for 2 nd week in January	12/20	BN, PH
Develop cost estimating packages for major components (modular, TF, PF, VV)	1/8	See below
Prepare new cost estimates for each system, complete project forms		
VV, PFCs (help for RF, Hyundai)	1/15	PG, BN
Modular Coils, trim coils (?) (help from AES, US Bronze, Southern Centrifugal, New England Wire, CTD)	1/22	DW, BN
TF, PF coils (help from Everson, AES?)	1/15	BN, TB
Cryostat, base structure	1/15	BN, TB