

RED INDICATES THAT MODELS / DRAWINGS ARE AT CHECKING OR HIGHER LEVEL

CAGE CODE	PART OR IDENTIFYING NO	NOMENCLATURE OR DESCRIPTION	MATERIAL	SPECIFICATION	FIND NO
←	NEXT ASSEMBLY	PARTS LIST			

NO REPRESENTATION OR WARRANTY, EXPRESSED OR IMPLIED, IS MADE AS TO THE ACCURACY, COMPLETENESS OR USEFULNESS OF THE INFORMATION OR STATEMENTS CONTAINED IN THESE DRAWINGS, OR THAT THE USE OR DISCLOSURE OF ANY INFORMATION, APPARATUS, METHOD OR PROCESS DISCLOSED IN THESE DRAWINGS MAY NOT INFRINGE PRIVATE RIGHTS OF OTHERS. NO LIABILITY IS ASSUMED WITH RESPECT TO THE USE OF, OR FOR DAMAGES RESULTING FROM THE USE OF, ANY INFORMATION, APPARATUS, METHOD OR PROCESS DISCLOSED IN THESE DRAWINGS. DRAWINGS MADE AVAILABLE FOR INFORMATION TO BIDDER ARE NOT TO BE USED FOR OTHER PURPOSES, AND ARE TO BE RETURNED UPON REQUEST OF THE FORWARDING CONTRACTOR.

**P** THIS DRAWING PRODUCED ON PRO-ENGINEER

REV	DESCRIPTION	BY	DATE	CHK	DEPT	DATE	PE	REQ	DATE	DRNL	DOE	DATE

SCALE NOTED	DES: WILLIAMSON	8/6/04
TOLERANCES UNLESS OTHERWISE SPECIFIED	CHK :	:
FRACTIONS	SECT :	:
XX DECIMALS ± .01	DEPT :	:
XXX DECIMALS ± .005	PE :	:
ANGLES ± 0'15"	CR :	:
BREAK SHARP EDGES 06 MAX	PJ :	:
FINISH .125 UNLESS OTHERWISE SPECIFIED	RED :	:
PPPL DRFT	PPPL DRFT :	:
DRAWING APPROVALS	DATE	DATE

<b>UT-BATTELLE</b>		Oak Ridge National Laboratory managed for the DEPARTMENT OF ENERGY under U.S. GOVERNMENT contract DE-AC05-00OR22725 UT-BATTELLE, LLC, Oak Ridge, Tennessee	
NATIONAL COMPACT STELLARATOR EXPERIMENT			
TRC MODEL TREE			
VERSION NO.	PLANT	BLDG	FL
	X-10	5700	3
RELEASE LEVEL	SHT OF	TYPE	CLASS
	1	A	U
	SE1406-009		

B SE1406-009

- NOTES:
1. INTERPRET DIMENSIONS AND TOLERANCES PER ANSI Y14.5M
  2. DIMENSIONS ARE IN INCHES
  3. DIMENSIONS APPLY AT ROOM TEMPERATURE. OPERATING TEMP 80 K.
  4. GEOMETRY IS DEFINED IN PRO ENGINEER CAD MODELS/FILES SE140-084.PRT
  5. DRAWING AND MODELS COMBINED DEFINE FINISHED MACHINED PART.
  6. MACHINE FINISHED SURFACES TO CAD DATA, PROFILE WITHIN 0.020" UNLESS OTHERWISE SPECIFIED. PROFILE TOLERANCE IS BILATERAL, i.e. 0.010" EITHER SIDE OF THE REFERENCE SURFACE.
  7. AS-CAST SURFACES SHOWN IN NOMINAL MATERIAL CONDITION, THICKNESS TOLERANCE +/- 0.25. SURFACE PROFILE MUST BE WITHIN 0.5 INCHES OF CAD DATA, EXCEPT IN REGIONS OF INTERSECTING SURFACES WHERE FILLETS ARE EXPECTED.
  8. SEE SPECIFICATION, NCSX-CSPEC 141-02-00 FOR ADDITIONAL REQUIREMENTS.
  9. SEE SPECIFICATION NCSX-CSPEC 141-02-00 SECTION 3.2.1.1 FOR MATERIAL REQUIREMENTS.)

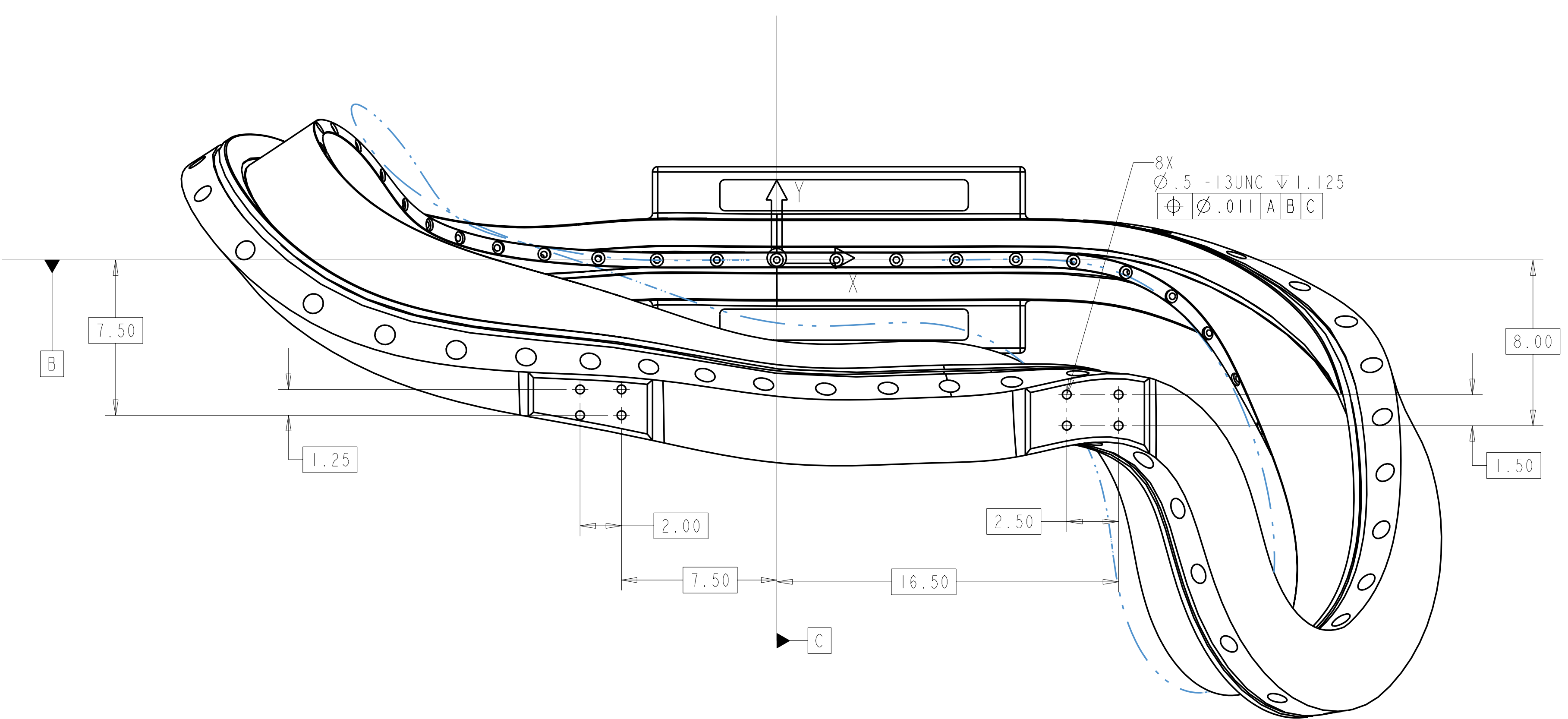

DATUM A = PLANE THRU "XY"  
 DATUM B = PLANE THRU "XZ"  
 DATUM C = PLANE THRU "YZ"

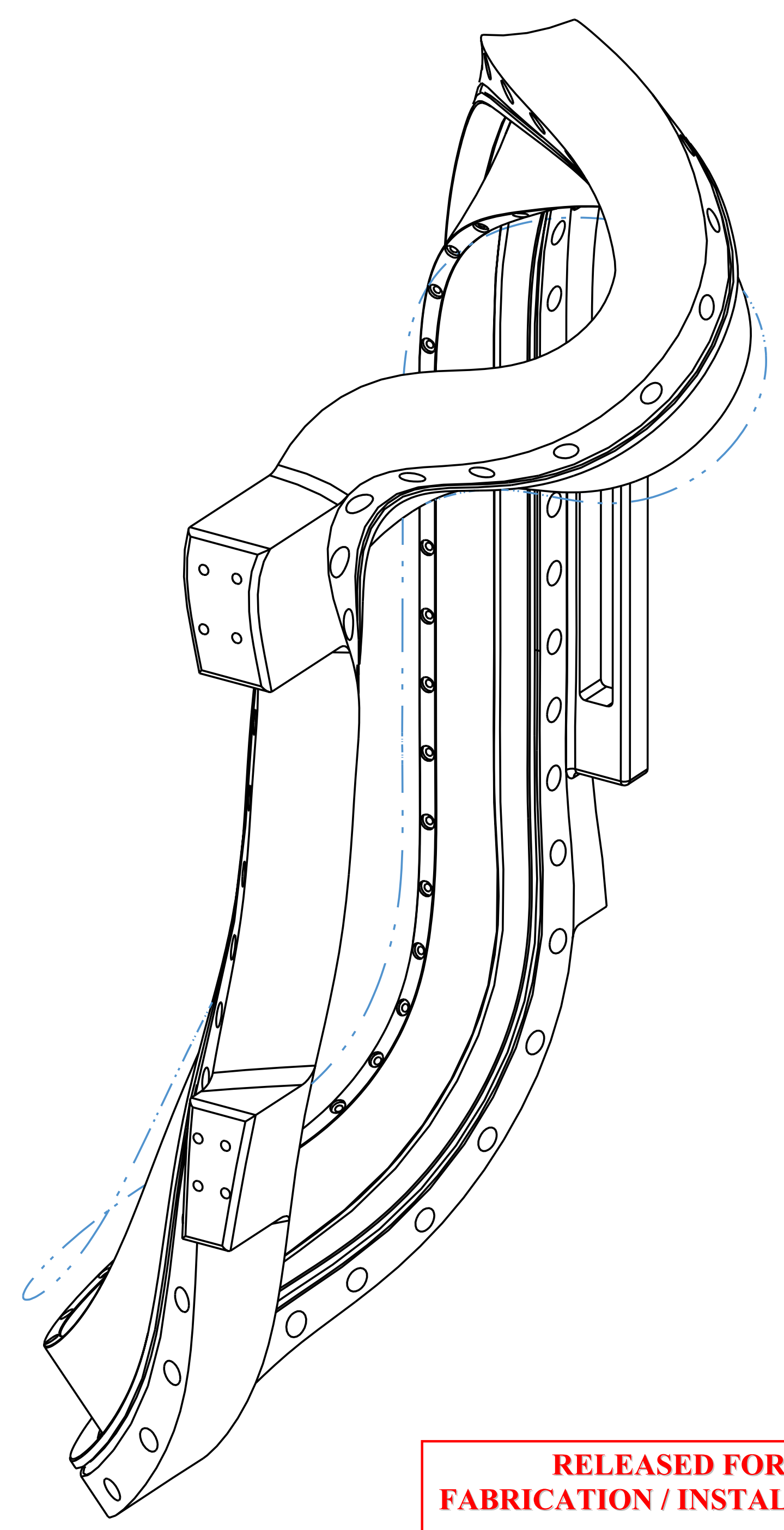
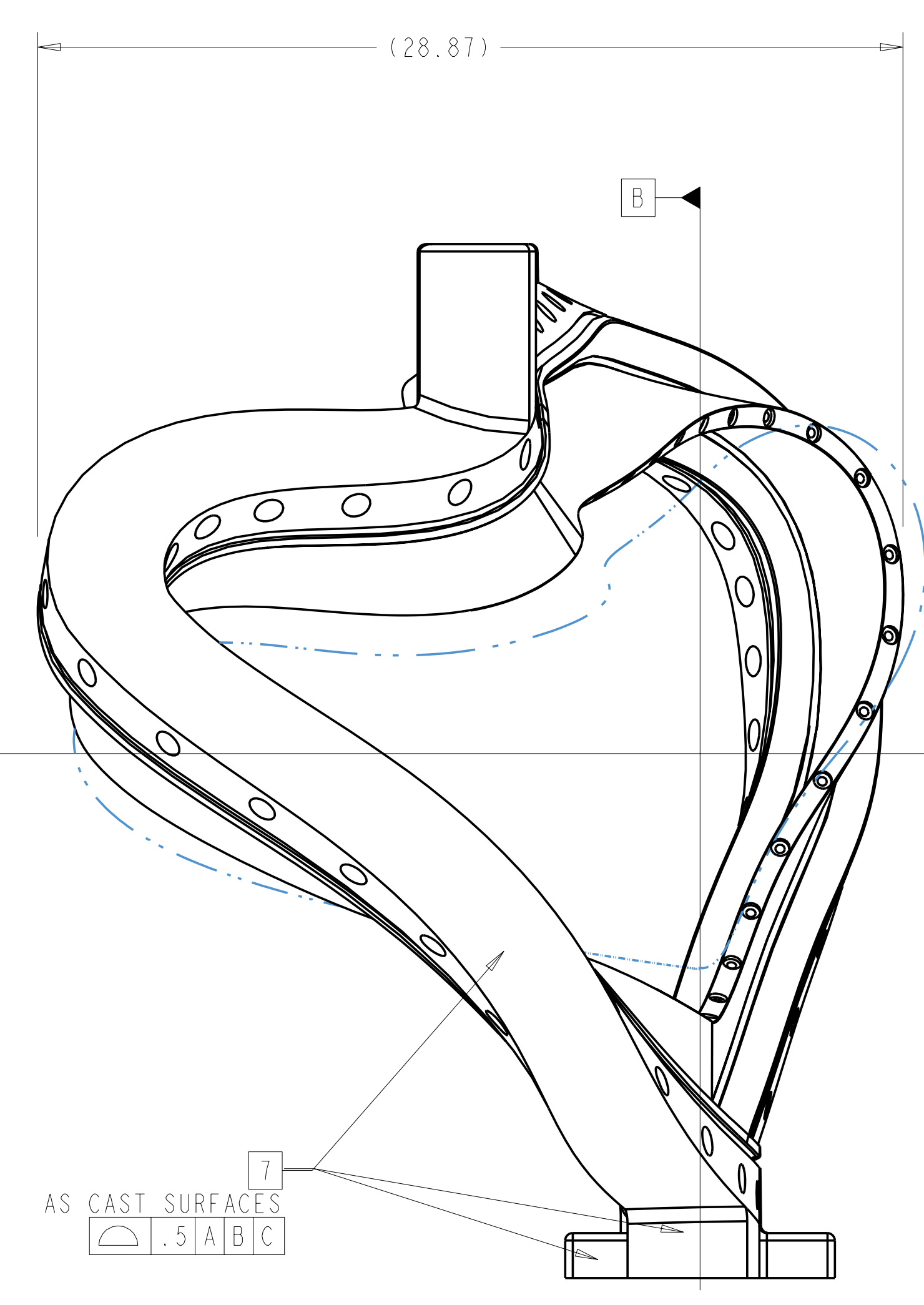
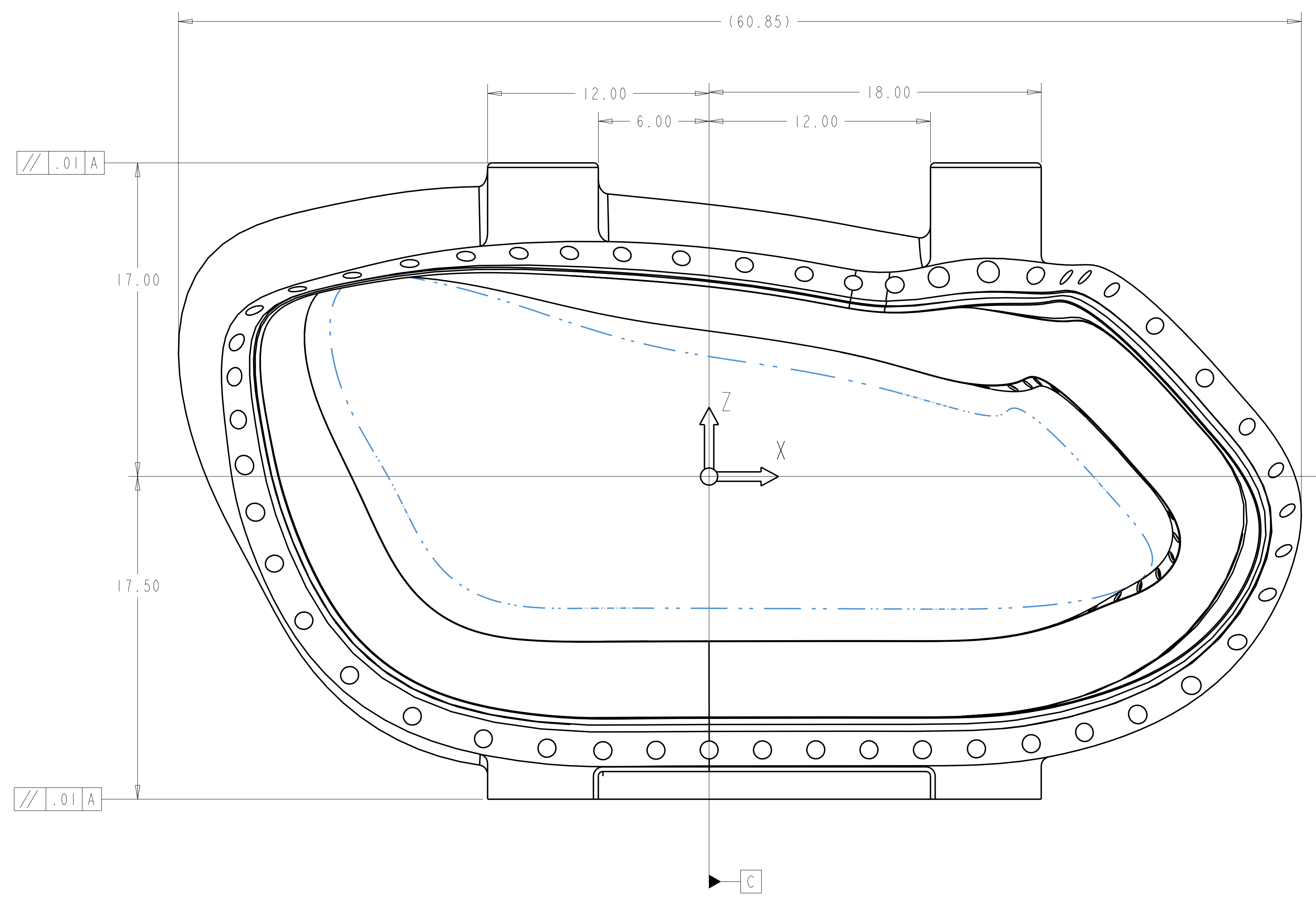

**RELEASED FOR FABRICATION / INSTALLATION**  
 PPPL Drafting

ISOMETRIC VIEW

REV	DESCRIPTION	BY	DATE	CHK	DEPT	DATE	PE	REQ	DATE	ORNL	DOE	DATE
1	REV 1 MODIFIED PER ECN# 4856	GLL	8-22-04									
2	MODIFIED VPI GROOVE DEPTH (.32 WAS .22)											

SCALE	DES	DRW	CHK	SECT	DEPT	PE	CR	PJ	REQ	PPPL DRFT	VERSION NO.	PLANT	BLDG	FL	SHT OF	TYPE	CLASS
SCALE .250 UNO	DES D. Williamson	DRW G. Lovett	CHK G. Jones	SECT :	DEPT :	PE :	CR :	PJ :	REQ :	PPPL DRFT :	VERSION NO. 13	PLANT X-10	BLDG 5700	FL 3	SHT OF 1	TYPE S	CLASS U

APPROXIMATE WEIGHT = 725 LBS

NO REPRESENTATION OR WARRANTY, EXPRESSED OR IMPLIED, IS MADE AS TO THE ACCURACY, COMPLETENESS OR USEFULNESS OF THE INFORMATION OR STATEMENTS CONTAINED IN THESE DRAWINGS, OR THAT THE USE OR DISCLOSURE OF ANY INFORMATION, APPARATUS, METHOD OR PROCESS DISCLOSED IN THESE DRAWINGS MAY NOT INFRINGE PRIVATE RIGHTS OF OTHERS. NO LIABILITY IS ASSUMED WITH RESPECT TO THE USE OF, OR FOR DAMAGES RESULTING FROM THE USE OF, ANY INFORMATION, APPARATUS, METHOD OR PROCESS DISCLOSED IN THESE DRAWINGS. DRAWINGS MADE AVAILABLE FOR INFORMATION TO BIDDER ARE NOT TO BE USED FOR OTHER PURPOSES, AND ARE TO BE RETURNED UPON REQUEST OF THE FORWARDING CONTRACTOR.

**P** THIS DRAWING PRODUCED ON PRO-ENGINEER

UT-BATTELLE NATIONAL COMPACT STELLARATOR EXPERIMENT TWISTED RACETRACK WINDING FORM											
Oak Ridge National Laboratory managed for the DEPARTMENT OF ENERGY under U.S. GOVERNMENT CONTRACT DE-AC05-00OR22725 UT-BATTELLE, LLC. Oak Ridge, Tennessee											
RELEASE LEVEL: Fabrication SEI40-084											

H  
G  
F  
E  
D  
C  
B  
A

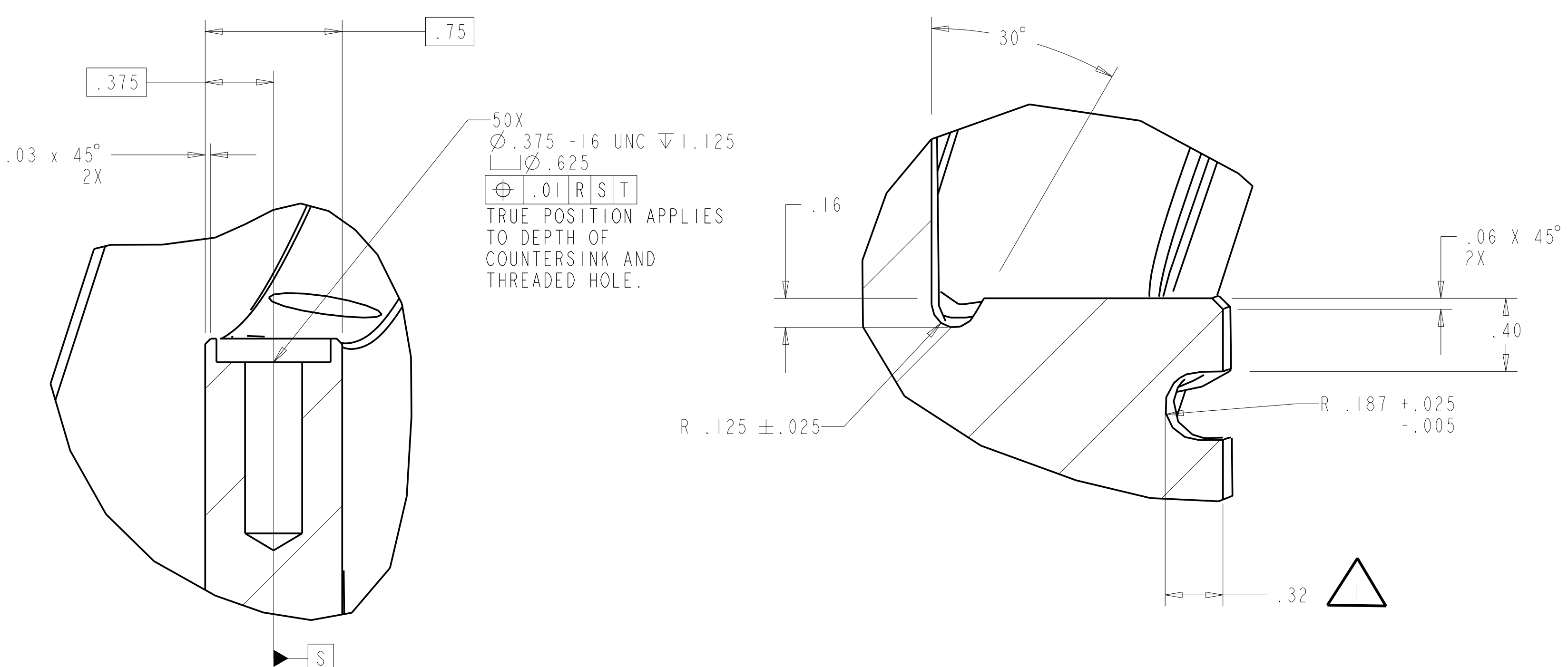

DETAIL 1  
SCALE 2.0

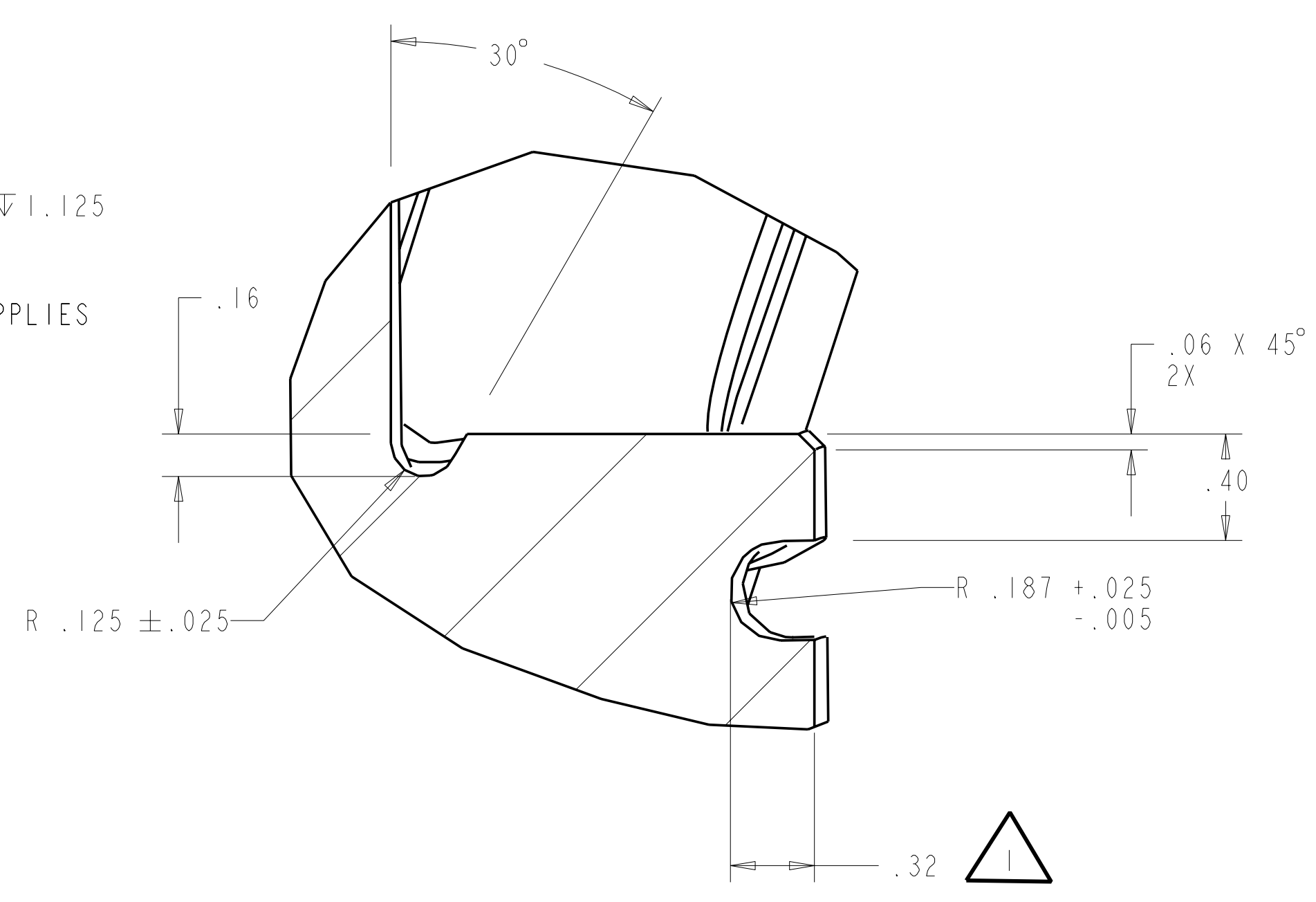

DETAIL 2  
SCALE 2.0  
VPI GROOVE TO BE MACHINED BY  
BALL END MILL OR DISC CUTTER IF  
SAME TOLERANCE CAN BE ACHIEVED.

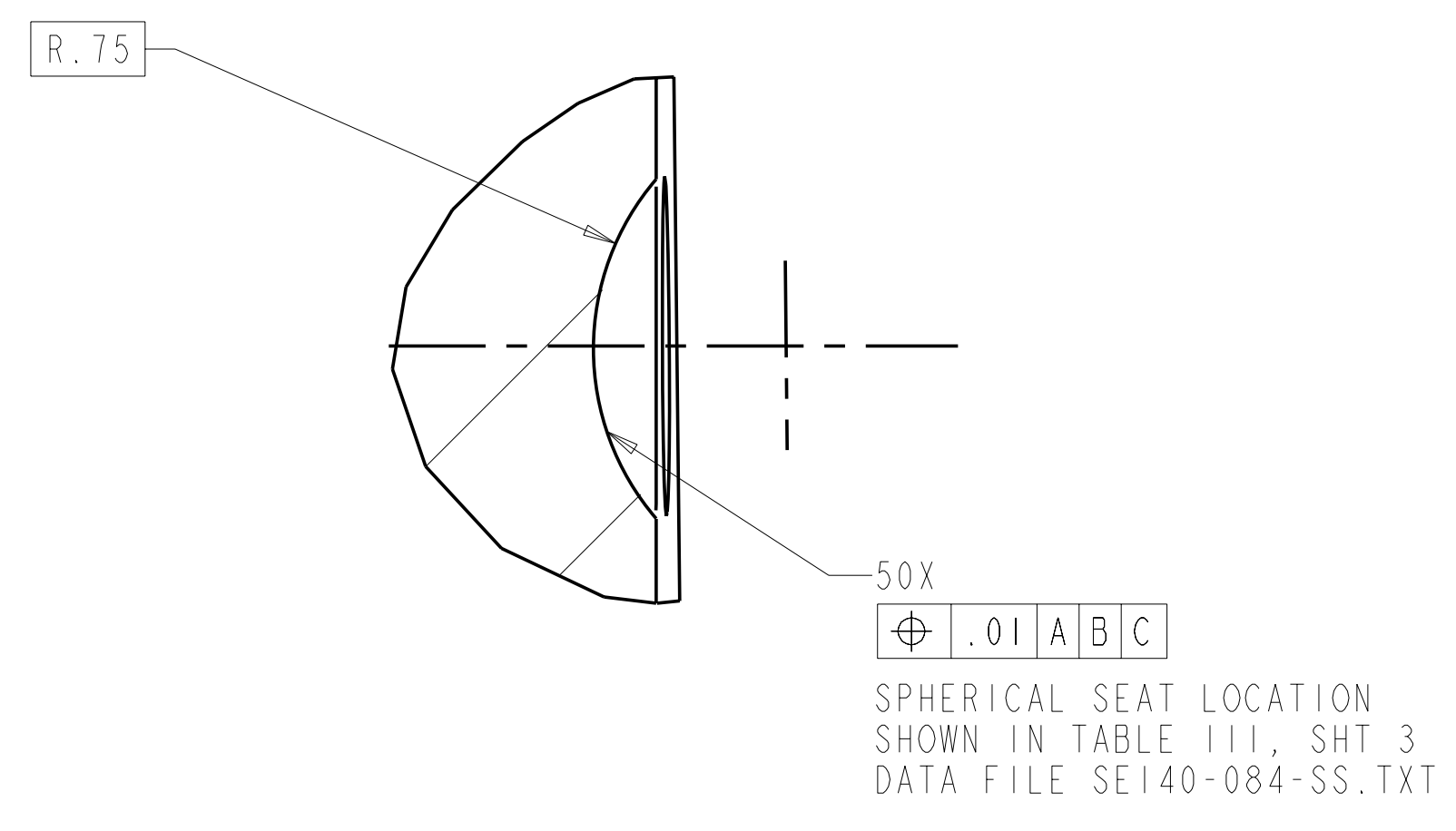

DETAIL 3  
SCALE 2.0

DATUM R = PLANE NORMAL TO WINDING CENTER  
 DATUM S = PLANE PASSING THRU WINDING CENTER AND  
 X-VECTOR AT DATUM R  
 DATUM T = PLANE PASSING THRU WINDING CENTER ORTHOGONAL  
 TO DATUM S

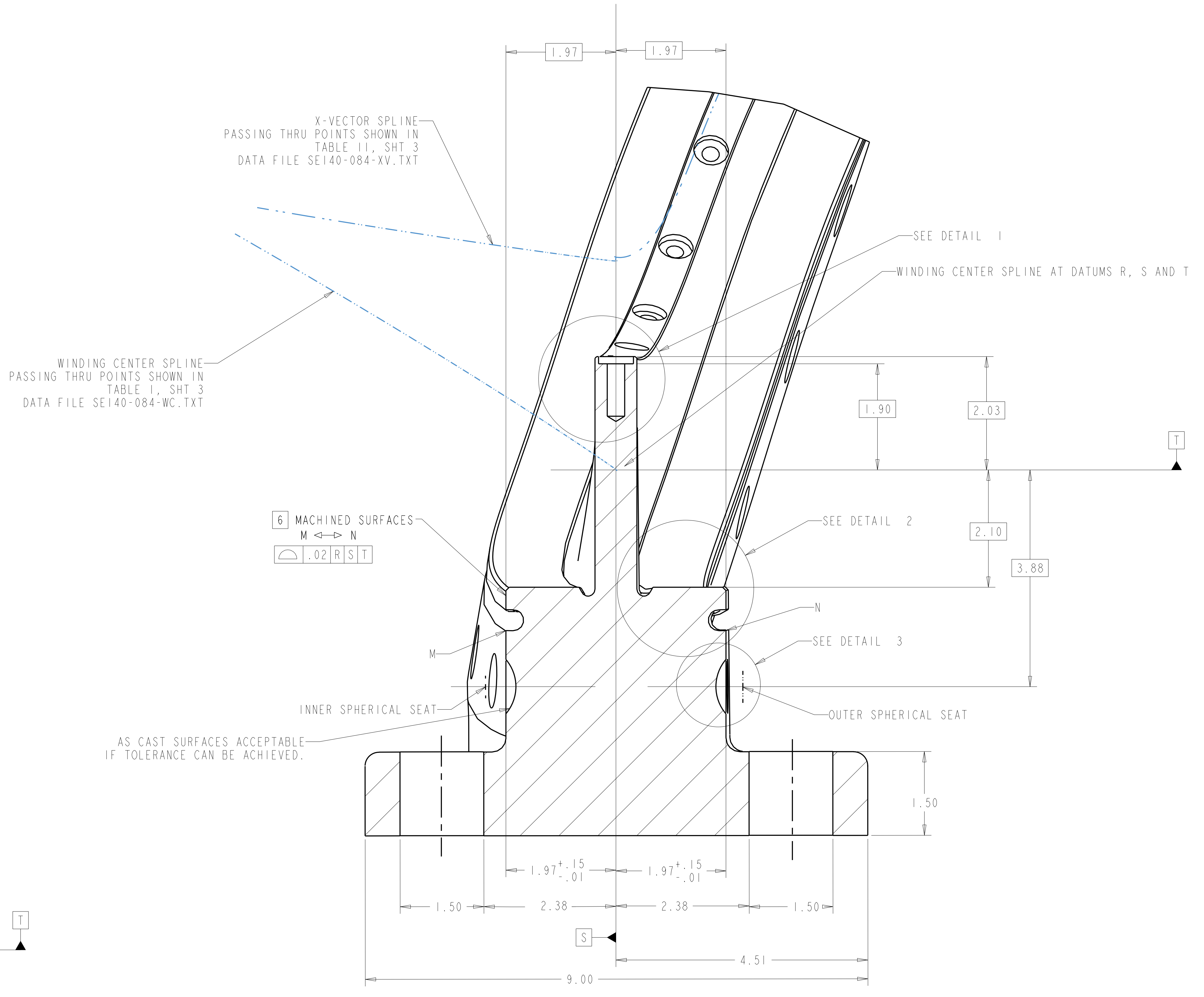
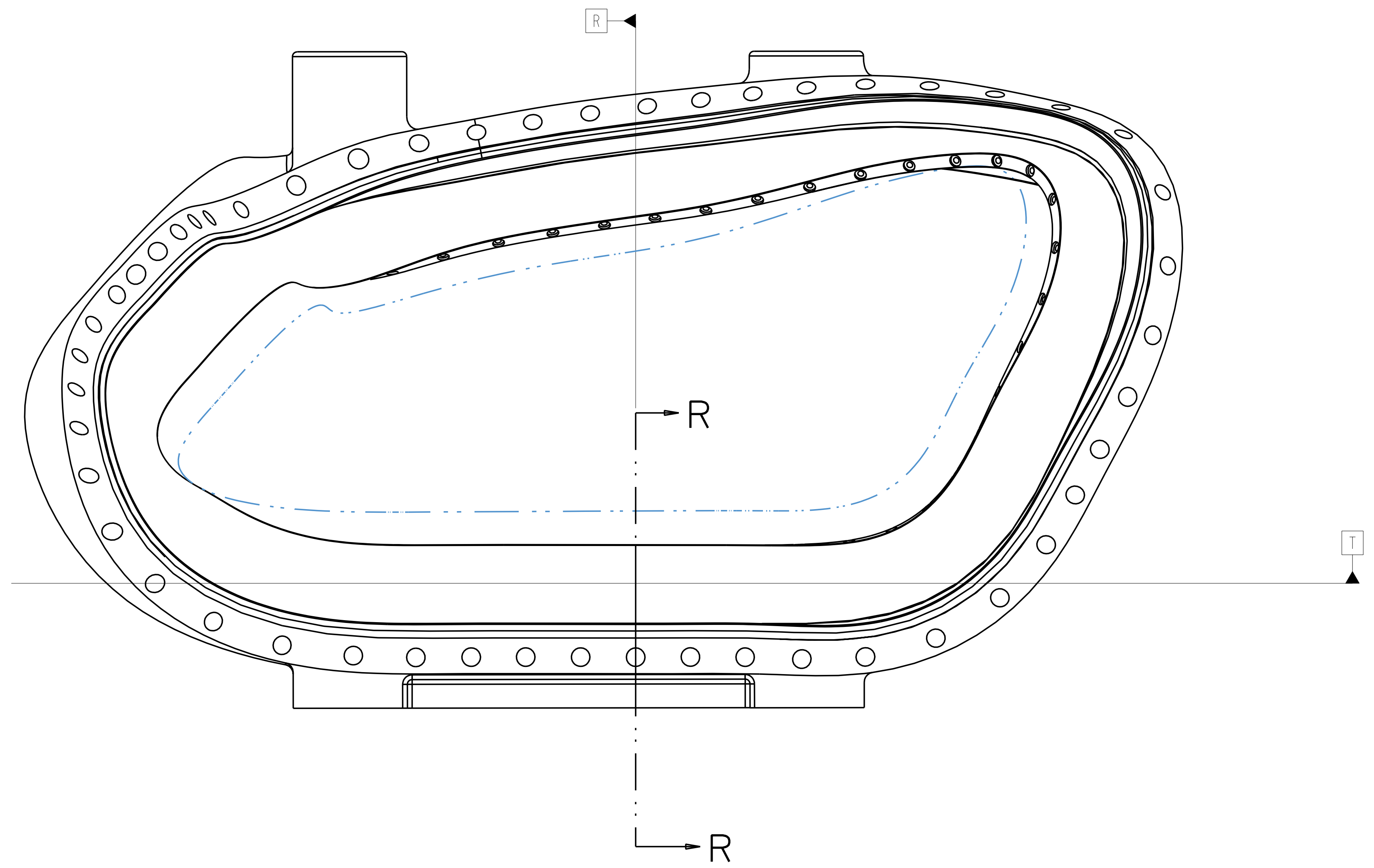

SECTION R-R  
SCALE 1.0  
APPLIES AT ALL POINTS  
ALONG WINDING CENTER

**RELEASED FOR  
FABRICATION / INSTALLATION**  
PPPL Drafting:

Oak Ridge National Laboratory managed for the DEPARTMENT OF ENERGY under U.S. GOVERNMENT contract DE-AC05-00OR22725 UT-BATTELLE, LLC, Oak Ridge, Tennessee PROJECT NAME							
<b>UT-BATTELLE</b> NATIONAL COMPACT STELLARATOR EXPERIMENT							
TWISTED RACETRACK WINDING FORM							
VERSION NO.	PLANT	BLDG	FL	SHT OF	TYPE	CLASS	
0	X-10	5700	3	2 3	S	U	
RELEASE LEVEL	SEI40-084						
Fabrication							

SEI40-084

TABLE I  
WINDING CENTER SPLINE CO-ORDINATE DATA FILE  
(FILE SE140-084-WC.TXT)

Winding Center Coordinates
No. X Y Z
1 0.000 -0.002 -10.953
2 2.888 0.000 -10.949
3 5.776 -0.001 -10.943
4 8.663 0.004 -10.941
5 11.551 0.022 -10.948
6 14.436 -0.064 -10.879
7 17.253 -0.559 -10.536
8 19.814 -1.656 -9.812
9 21.983 -3.261 -8.800
10 23.752 -5.211 -7.621
11 25.159 -7.389 -6.355
12 26.194 -9.738 -5.037
13 26.839 -12.205 -3.688
14 27.012 -14.732 -2.310
15 26.577 -17.184 -0.862
16 25.442 -19.264 0.767
17 23.707 -20.381 2.725
18 21.776 -19.871 4.754
19 20.163 -17.961 6.131
20 19.161 -15.315 6.616
21 18.513 -12.503 6.551
22 17.430 -9.840 6.500
23 15.490 -7.744 6.789
24 13.018 -6.372 7.327
25 10.303 -5.628 7.950
26 7.489 -5.400 8.544
27 4.650 -5.491 9.059
28 1.796 -5.531 9.490
29 -1.050 -5.228 9.856
30 -3.841 -4.581 10.216
31 -6.584 -3.789 10.646
32 -9.331 -3.046 11.134
33 -12.109 -2.381 11.559
34 -14.894 -1.656 11.781
35 -17.614 -0.692 11.762
36 -20.149 0.657 11.512
37 -22.263 2.438 10.737
38 -23.533 4.238 9.929
39 -23.706 5.254 9.268
40 -23.071 5.377 8.467
41 -22.027 4.851 7.504
42 -20.898 3.781 -1.596
43 -19.793 2.538 -3.956
44 -18.484 1.554 -6.330
45 -16.675 0.825 -8.448
46 -14.296 0.267 -9.966
47 -11.539 -0.018 -10.741
48 -8.663 -0.029 -10.966
49 -5.775 0.012 -10.976
50 -2.888 0.005 -10.959

TABLE II  
X VECTOR CURVE CO-ORDINATE DATA FILE  
(FILE SE140-084-XV.TXT)

X-Vector Coordinates
No. X Y Z
1 -0.005 0.002 -7.153
2 2.880 0.000 -7.162
3 5.768 -0.001 -7.171
4 8.670 0.003 -7.181
5 11.545 0.032 -7.194
6 14.215 -0.081 -7.188
7 16.558 -0.629 -7.118
8 18.649 -1.817 -6.951
9 20.438 -3.632 -6.678
10 21.871 -5.873 -6.314
11 22.921 -8.320 -5.874
12 23.624 -10.820 -5.366
13 23.986 -13.286 -4.781
14 23.970 -15.592 -4.096
15 23.555 -17.718 -3.238
16 22.605 -19.612 -2.016
17 20.776 -20.864 0.044
18 18.847 -20.336 2.076
19 17.351 -18.448 3.349
20 16.503 -15.879 3.705
21 16.113 -13.284 3.508
22 15.645 -10.814 3.291
23 14.531 -8.132 3.382
24 12.549 -5.559 3.892
25 9.886 -3.700 4.639
26 6.878 -3.032 5.357
27 4.013 -3.125 5.885
28 1.441 -3.170 6.280
29 -1.028 -2.869 6.672
30 -3.598 -2.165 7.198
31 -6.303 -1.199 7.943
32 -9.031 -0.243 8.835
33 -11.625 0.615 9.684
34 -14.017 1.487 10.335
35 -16.197 2.510 10.779
36 -18.017 3.723 10.948
37 -19.371 5.053 10.655
38 -20.339 6.547 9.443
39 -20.473 7.469 7.022
40 -19.770 7.259 4.400
41 -18.553 6.114 1.978
42 -17.280 4.385 -0.222
43 -16.198 2.810 -2.352
44 -15.119 1.848 -4.219
45 -13.938 1.312 -5.521
46 -12.606 0.928 -6.368
47 -10.923 0.558 -6.911
48 -8.573 0.174 -7.148
49 -5.802 -0.017 -7.146
50 -2.902 -0.010 -7.142

TABLE III  
SPHERICAL SEAT LOCATION CO-ORDINATES  
(FILE SE140-084-SS.TXT)

No.	Spherical Seat - Left			Spherical Seat - Right		
	X	Y	Z	X	Y	Z
1 0.000 -2.546 -14.830						
2 2.896 -2.540 -14.829						
3 5.782 -2.541 -14.823						
4 8.669 -2.535 -14.822						
5 11.561 -2.528 -14.821						
6 14.462 -2.578 -14.776						
7 17.351 -2.922 -14.525						
8 20.195 -3.682 -13.966						
9 23.112 -4.670 -13.071						
10 26.112 -5.753 -11.576						
11 28.713 -7.170 -9.326						
12 30.448 -9.231 -6.815						
13 31.399 -11.838 -4.449						
14 31.647 -14.891 -2.240						
15 31.037 -18.108 0.011						
16 29.424 -20.916 2.476						
17 26.955 -22.421 5.332						
18 24.037 -21.668 8.381						
19 21.526 -18.866 10.470						
20 19.969 -15.302 11.182						
21 18.953 -12.144 11.153						
22 17.458 -10.028 11.134						
23 15.127 -9.340 11.128						
24 12.525 -9.556 10.663						
25 10.097 -9.730 10.103						
26 7.777 -9.738 10.156						
27 5.115 -9.828 10.634						
28 1.859 -9.869 11.128						
29 -1.606 -9.532 11.493						
30 -4.817 -8.871 11.683						
31 -7.660 -8.168 11.726						
32 -10.363 -7.536 11.664						
33 -13.194 -6.888 11.458						
34 -16.213 -6.038 11.032						
35 -19.299 -4.781 10.367						
36 -22.242 -3.016 9.607						
37 -24.450 -0.999 8.521						
38 -25.276 0.401 6.994						
39 -25.385 1.038 5.312						
40 -25.234 1.292 3.088						
41 -24.999 1.296 0.662						
42 -24.547 0.926 -1.791						
43 -23.594 -0.052 -4.542						
44 -21.999 -1.158 -7.670						
45 -19.520 -2.100 -10.651						
46 -16.108 -2.845 -12.888						
47 -12.195 -3.098 -14.146						
48 -8.706 -2.772 -14.705						
49 -5.736 -2.499 -14.875						
50 -2.887 -2.520 -14.849						

ALL POINT LOCATION IN TABLES ARE BASIC DIMENSIONS TO DATUMS A, B, AND C

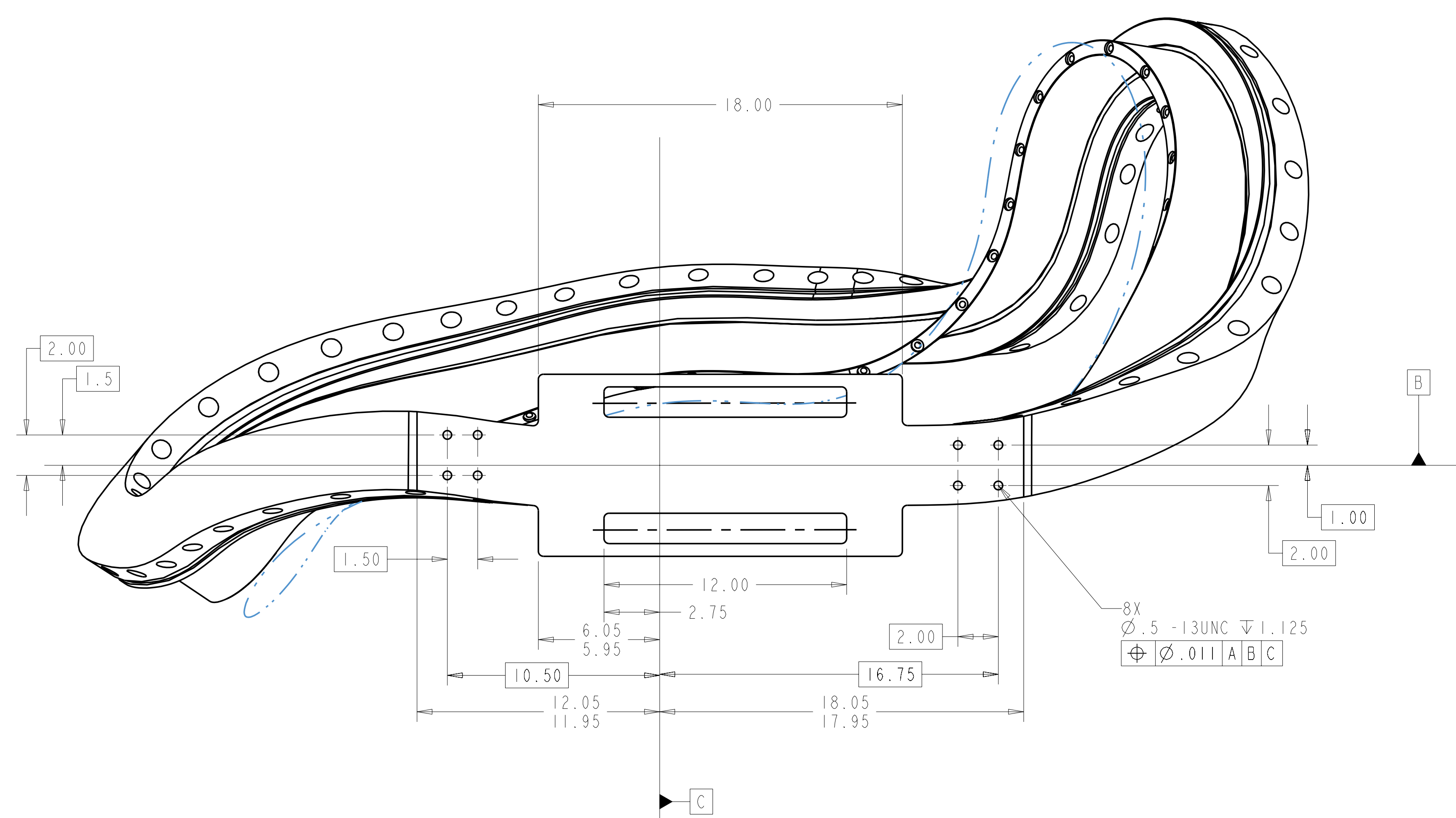

**RELEASED FOR  
FABRICATION / INSTALLATION**

PPPL Drafting:

<b>UT-BATTELLE</b> Oak Ridge National Laboratory managed for the DEPARTMENT OF ENERGY under U.S. GOVERNMENT contract DE-AC05-00OR22725 UT-BATTELLE, LLC. Oak Ridge, Tennessee							
<b>NATIONAL COMPACT STELLARATOR EXPERIMENT</b>							
<b>TWISTED RACETRACK WINDING FORM</b>							
VERSION NO. 0	PLANT X-10	BLDG 5700	FL 3	SHT OF 3	TYPE S	CLASS U	REV I
RELEASE LEVEL Fabrication		SE140-084					



8

7

6

5

4

3

2

1

NEXT ASS'Y: 1 FINAL ASS'Y:

H

H

G

G

F

F

E

E

D

D

C

C

B

B

A

A

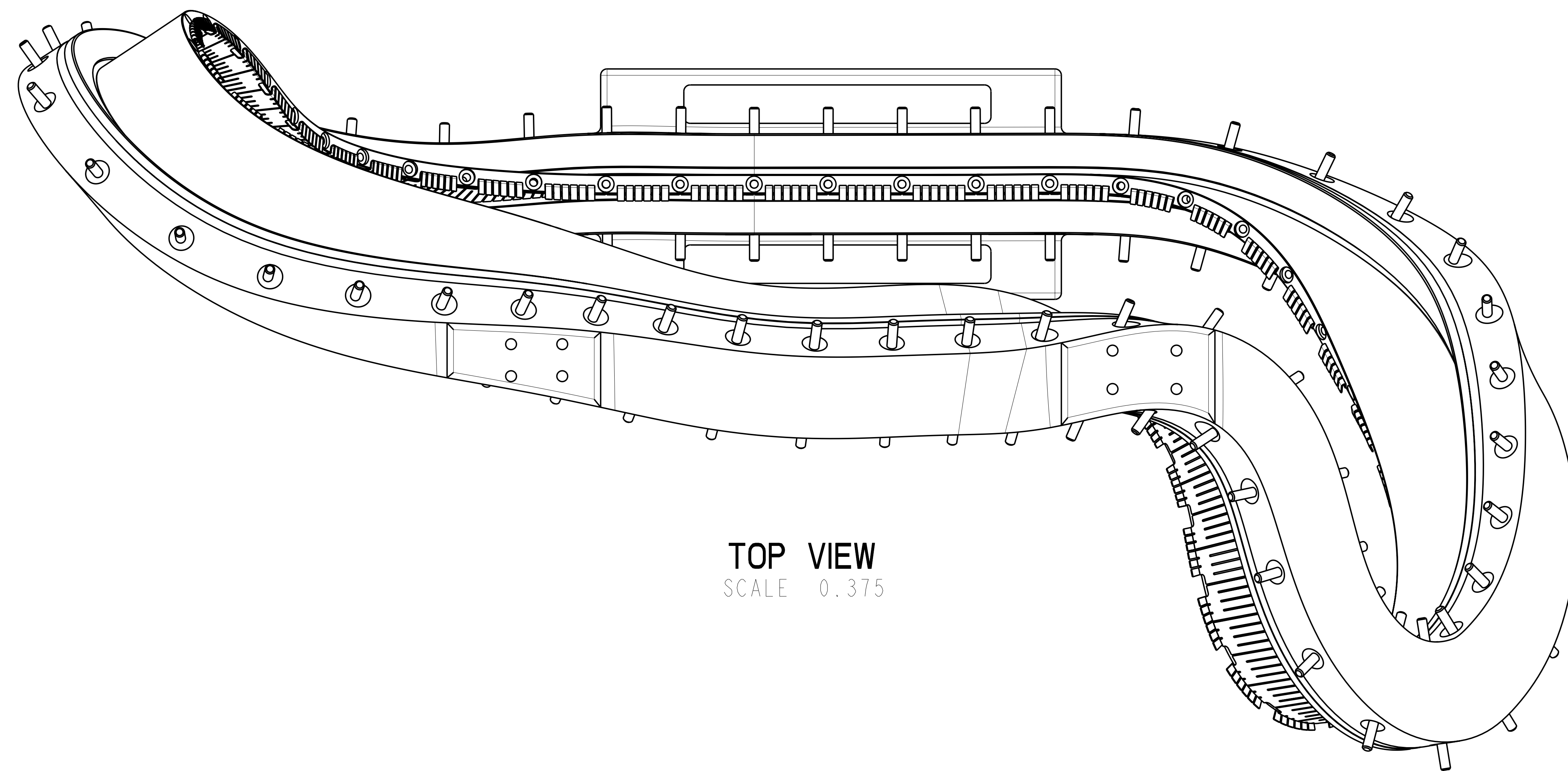

TOP VIEW  
SCALE 0.375

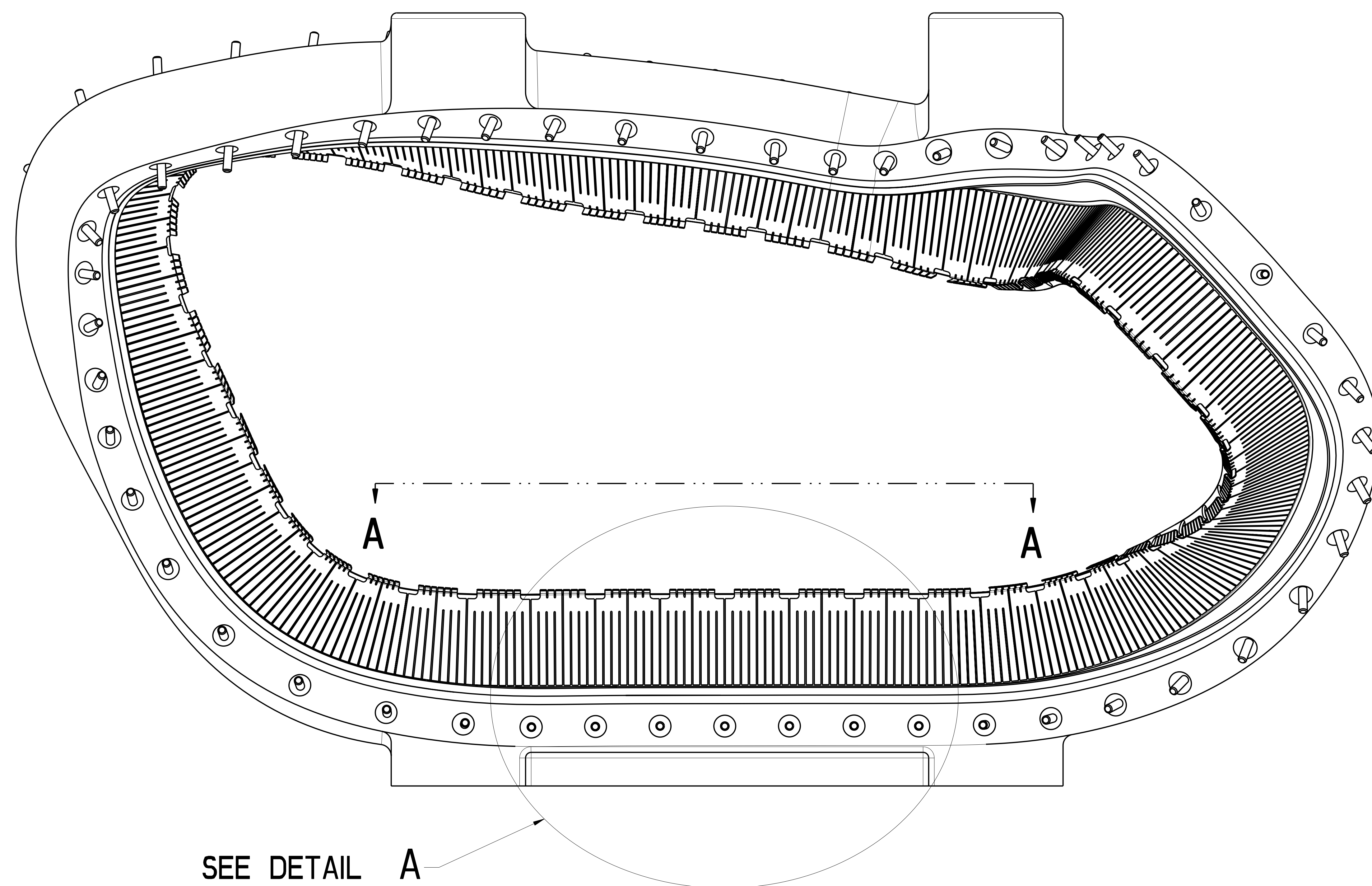

SEE DETAIL A

Oak Ridge National Laboratory managed for the DEPARTMENT OF ENERGY under U.S. GOVERNMENT contract DE-AC05-00OR22725 UT-BATTELLE, LLC, Oak Ridge, Tennessee PROJECT NAME:						
<b>UT-BATTELLE</b> <b>NATIONAL COMPACT STELLARATOR EXPERIMENT</b>						
<b>RACETRACK</b> <b>SIDE I WEB COPPER CLADDING</b> <b>FABRICATED INSTALLATION</b>						
VERSION NO:	PLANT	BLDG	FL	SHT	OF	TYPE CLASS
2+		5700	3	2	5	U
RELEASE LEVEL		SE140-283			REV	
Fabrication					0	

8

7

6

5

4

3

2

1

SE140-283

8

7

6

5

4

3

2

1

NEXT ASS'Y: 1 FINAL ASS'Y:

H

H

G

G

F

F

E

E

D

D

C

C

B

B

A

A

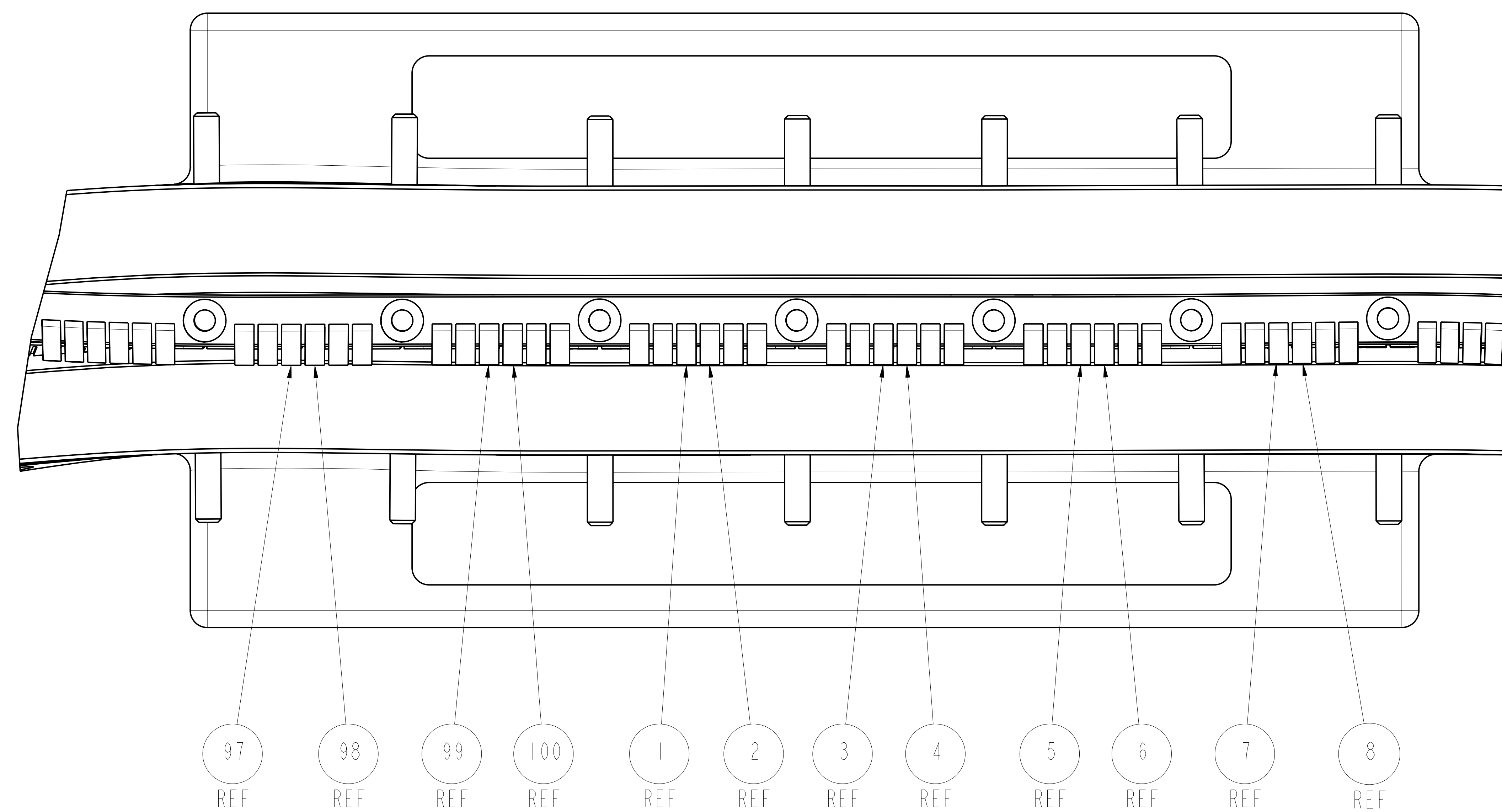

SECTION A-A

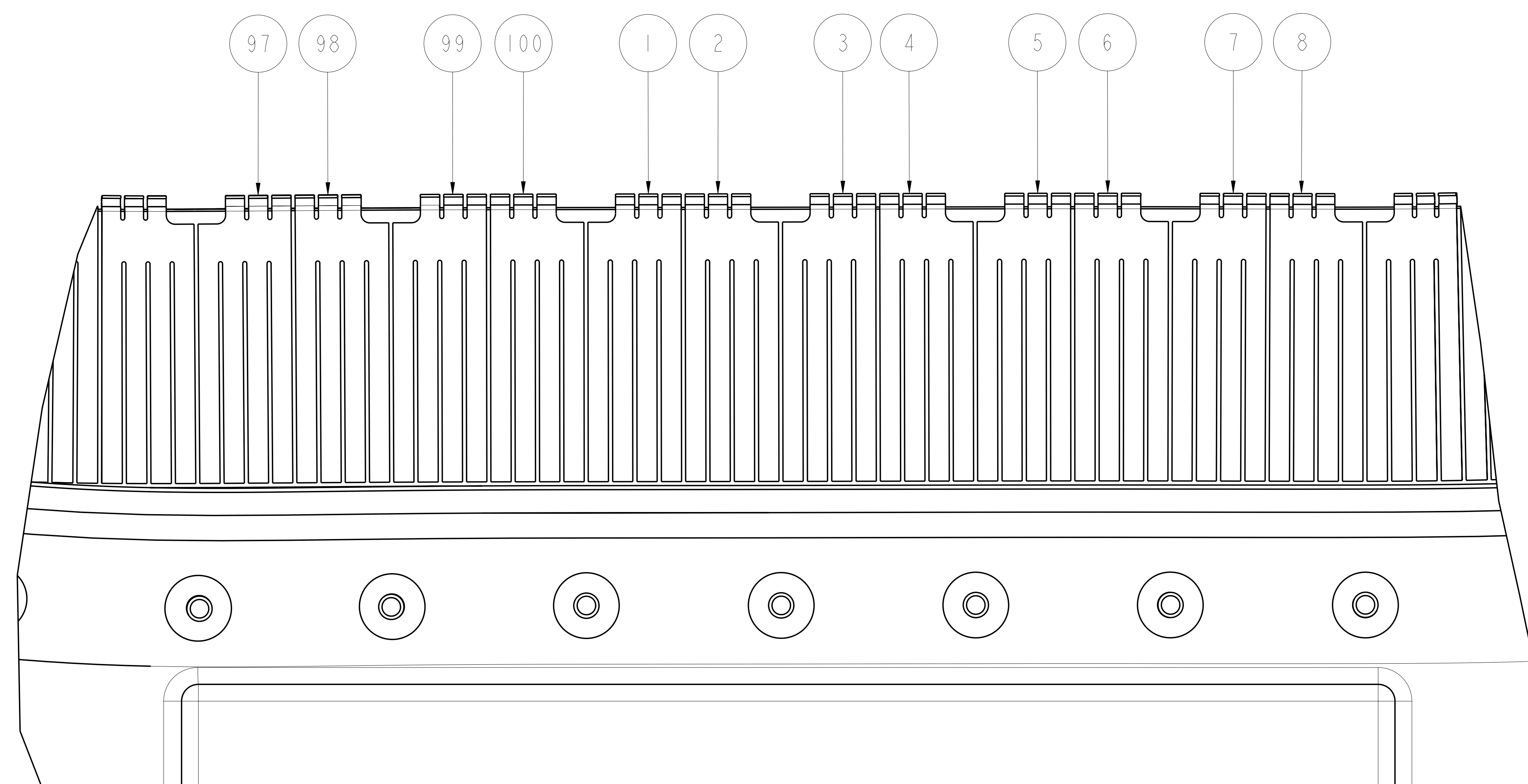

DETAIL A  
SCALE 1.00

Oak Ridge National Laboratory managed for the DEPARTMENT OF ENERGY under U.S. GOVERNMENT contract DE-AC05-00OR22725 UT-BATTELLE, LLC, Oak Ridge, Tennessee PROJECT NAME:						
<b>UT-BATTELLE</b> NATIONAL COMPACT STELLARATOR EXPERIMENT						
RACETRACK SIDE I WEB COPPER CLADDING FABRICATED INSTALLATION						
VERSION NO:	PLANT	BLDG	FL	SHT	OF	TYPE CLASS
2+		5700	3	3	5	U
RELEASE LEVEL		SE140-283			REV	
Fabrication					0	

8

7

6

5

4

3

2

1

SE140-283

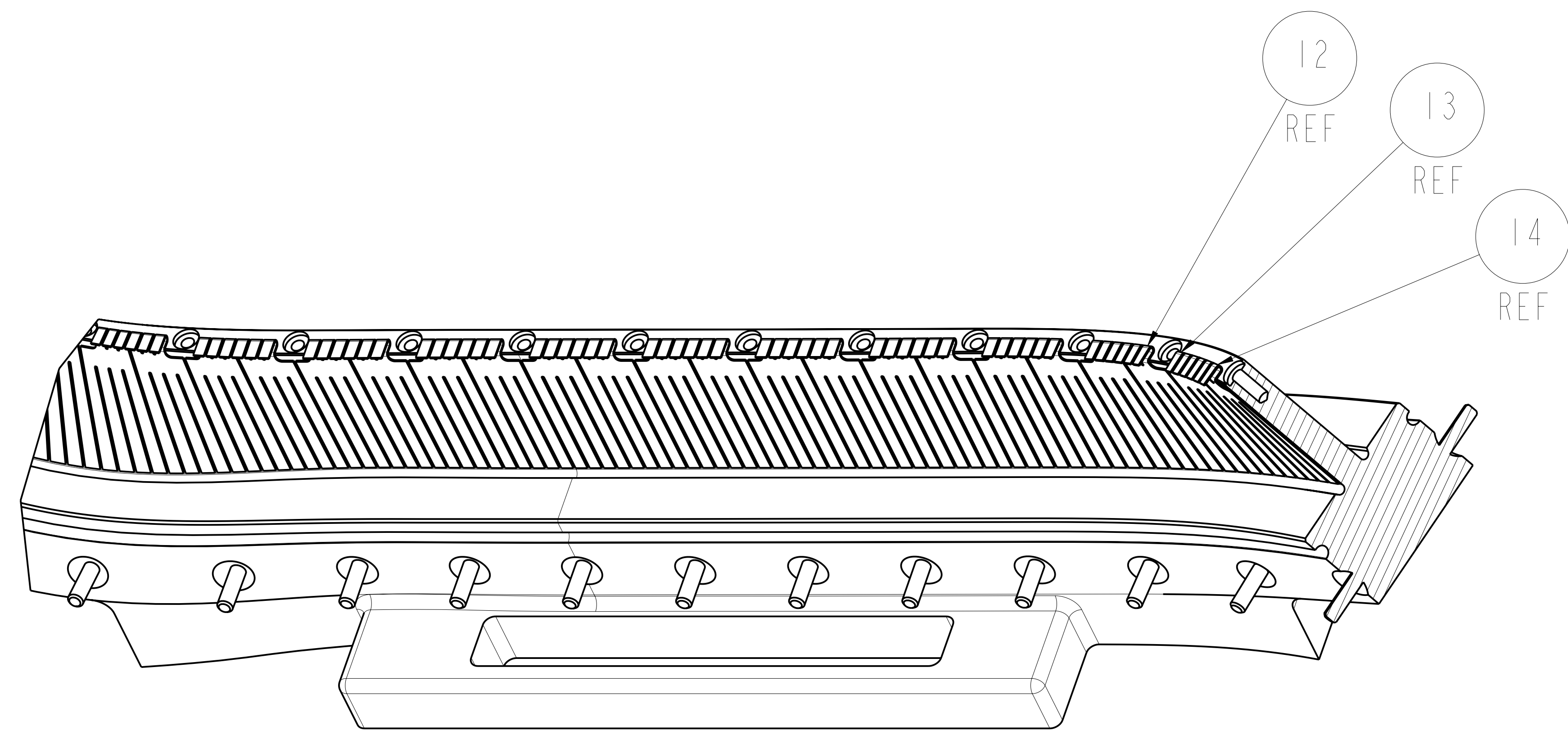

SECTION B-B TRIMETRIC VIEW  
 DETAILS TYPICAL OF CLAD AT CLAMP INTERFACES  
 SCALE 0.50

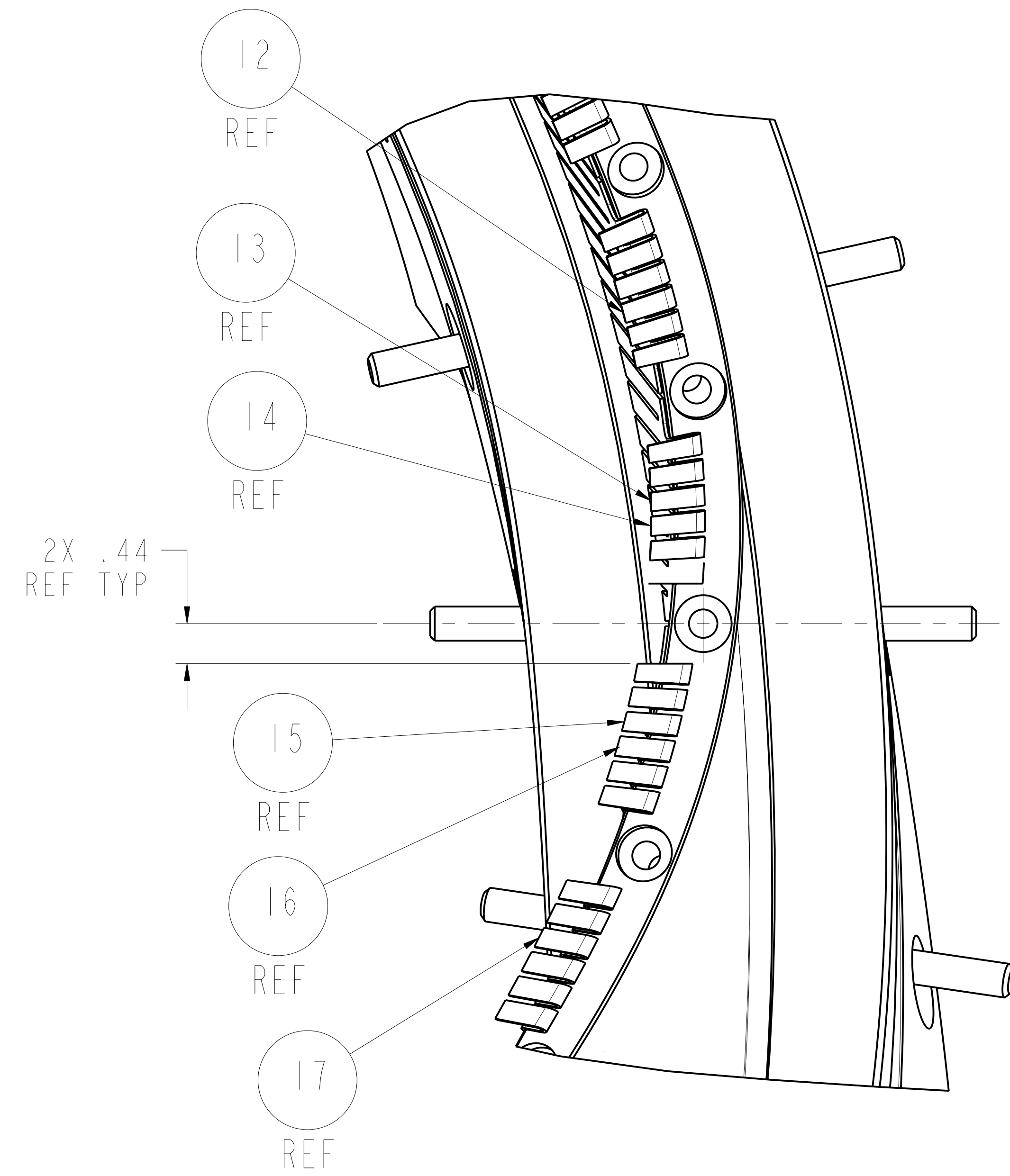

SECTION B-B  
 ROTATED AND CLIPPED FOR CLARITY

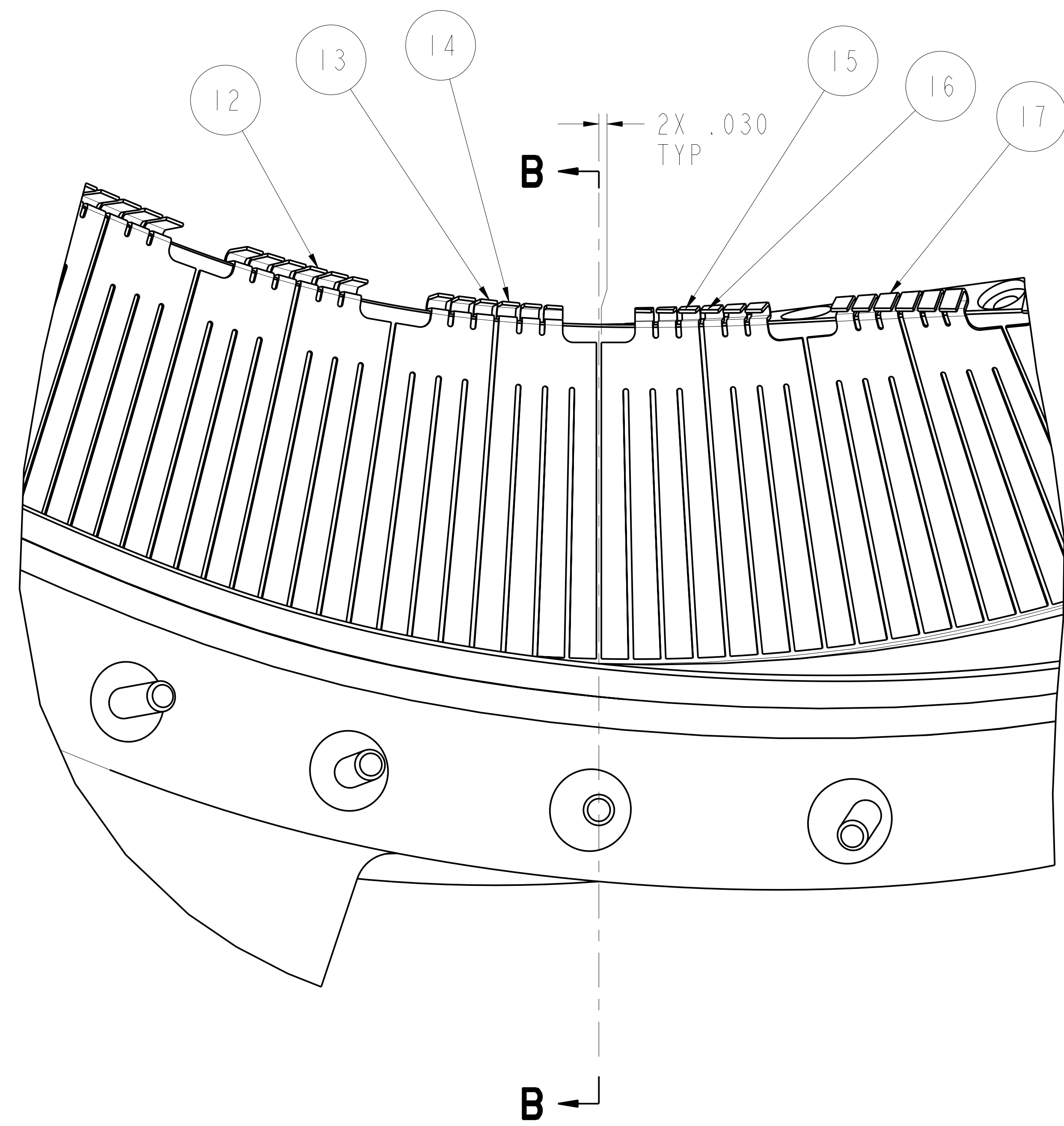

VIEW PERPIDICULAR TO WINDING  
 SURFACE AT CLAMP INTERFACE  
 SCALE 1.00

Oak Ridge National Laboratory managed for the DEPARTMENT OF ENERGY under U.S. GOVERNMENT CONTRACT DE-AC05-00OR22725 UT-BATTELLE, LLC, Oak Ridge, Tennessee PROJECT NAME						
<b>NATIONAL COMPACT STELLARATOR EXPERIMENT</b>						
<b>RACETRACK</b> <b>SIDE I WEB COPPER CLADDING</b> <b>FABRICATED INSTALLATION</b>						
VERSION NO.	PLANT	BLDG	FL	SHT	OF	TYPE CLASS
2+		5700	3	4	5	U
RELEASE LEVEL		SE140-283			REV	
Fabrication					0	



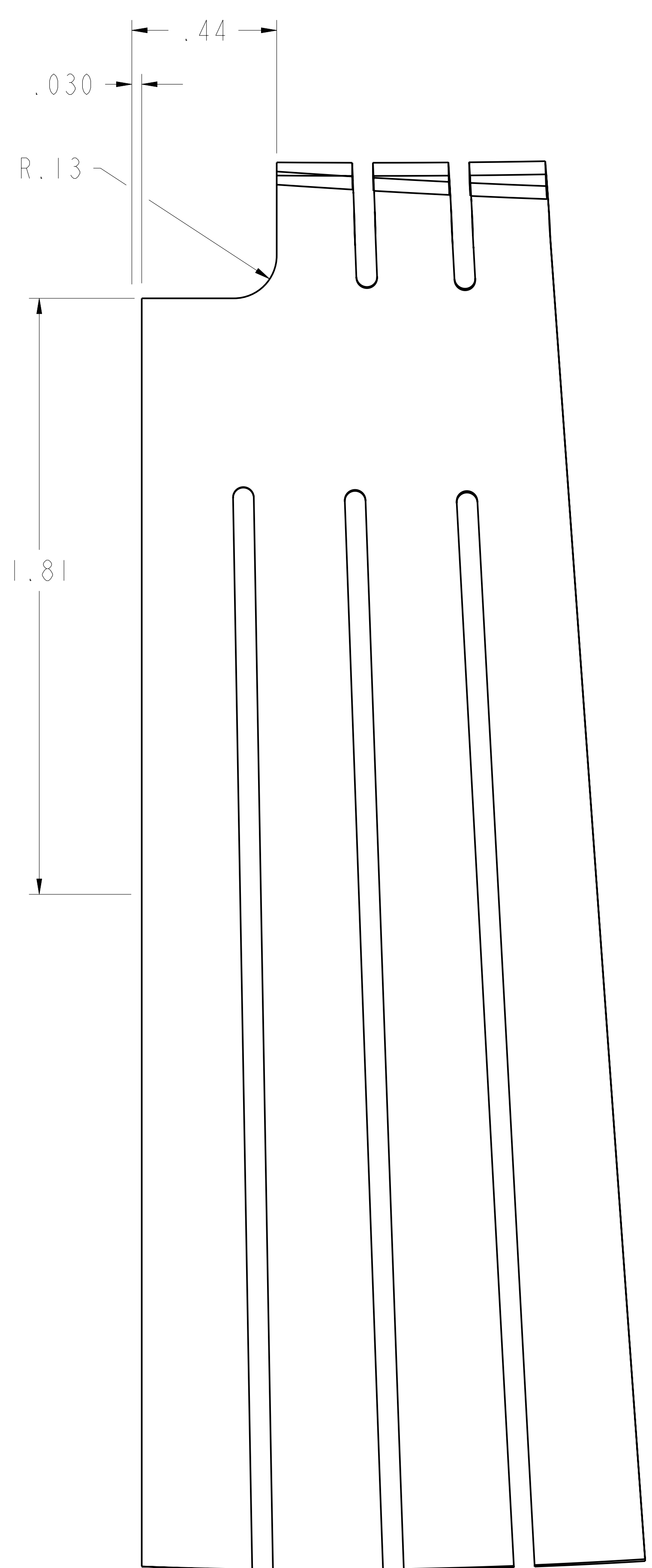

VIEW NORMAL TO MATING PART WINDING SURFACE AT WINDING CENTER LENGTH RATIO LEFT BOUND

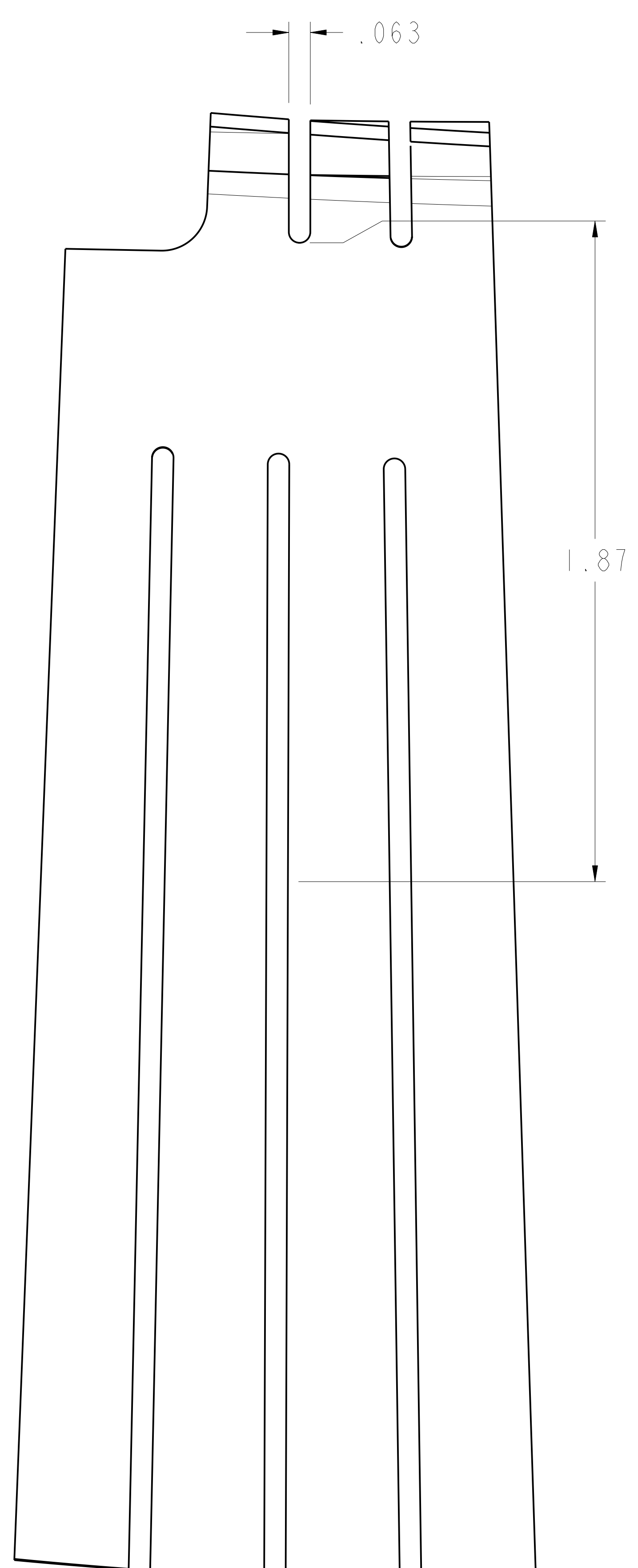

VIEW NORMAL TO MATING PART WINDING SURFACE AT POINT UNIFORMLY DIVIDING BENT-OVER TABS ALONG THE WINDING CENTER, TYPICAL

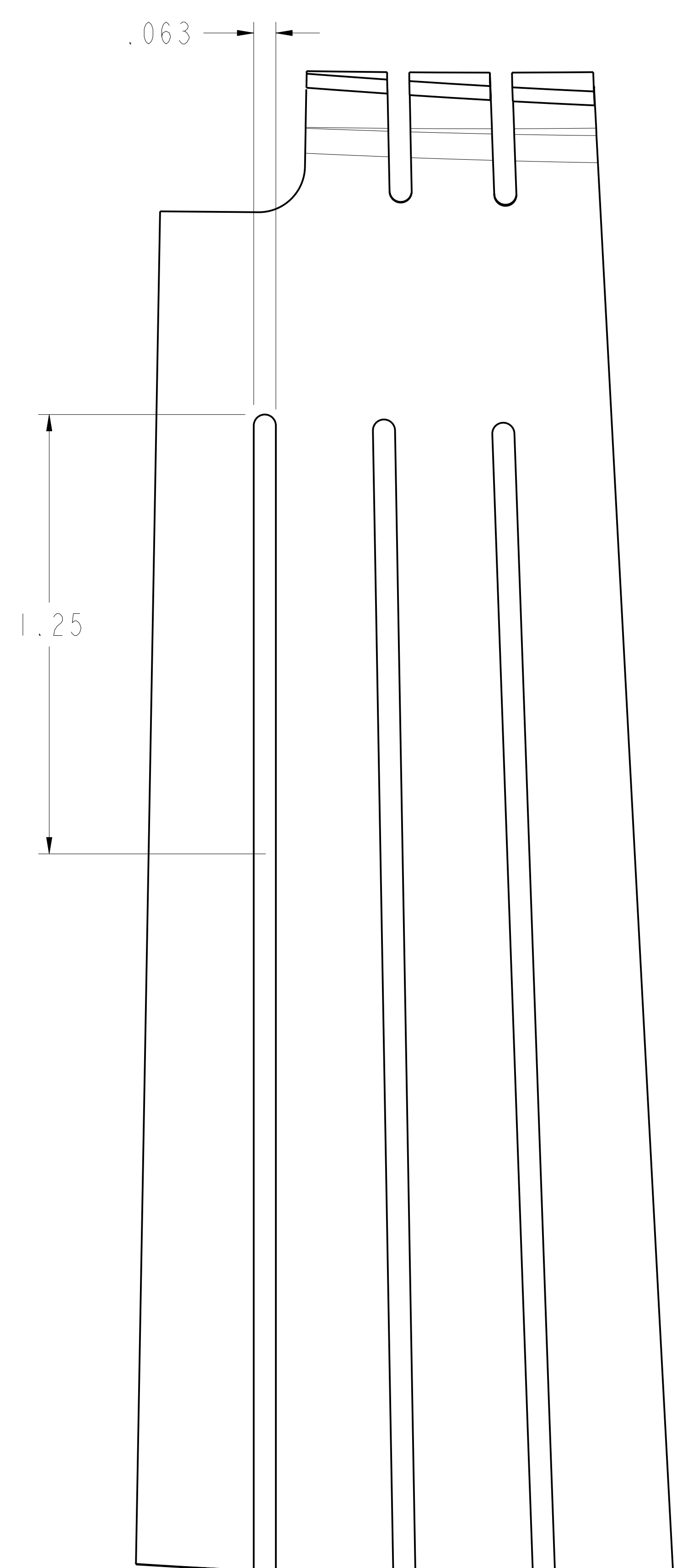

VIEW NORMAL TO MATING PART WINDING SURFACE AT POINT UNIFORMLY DIVIDING WEB REGION ALONG THE WINDING CENTER, TYPICAL

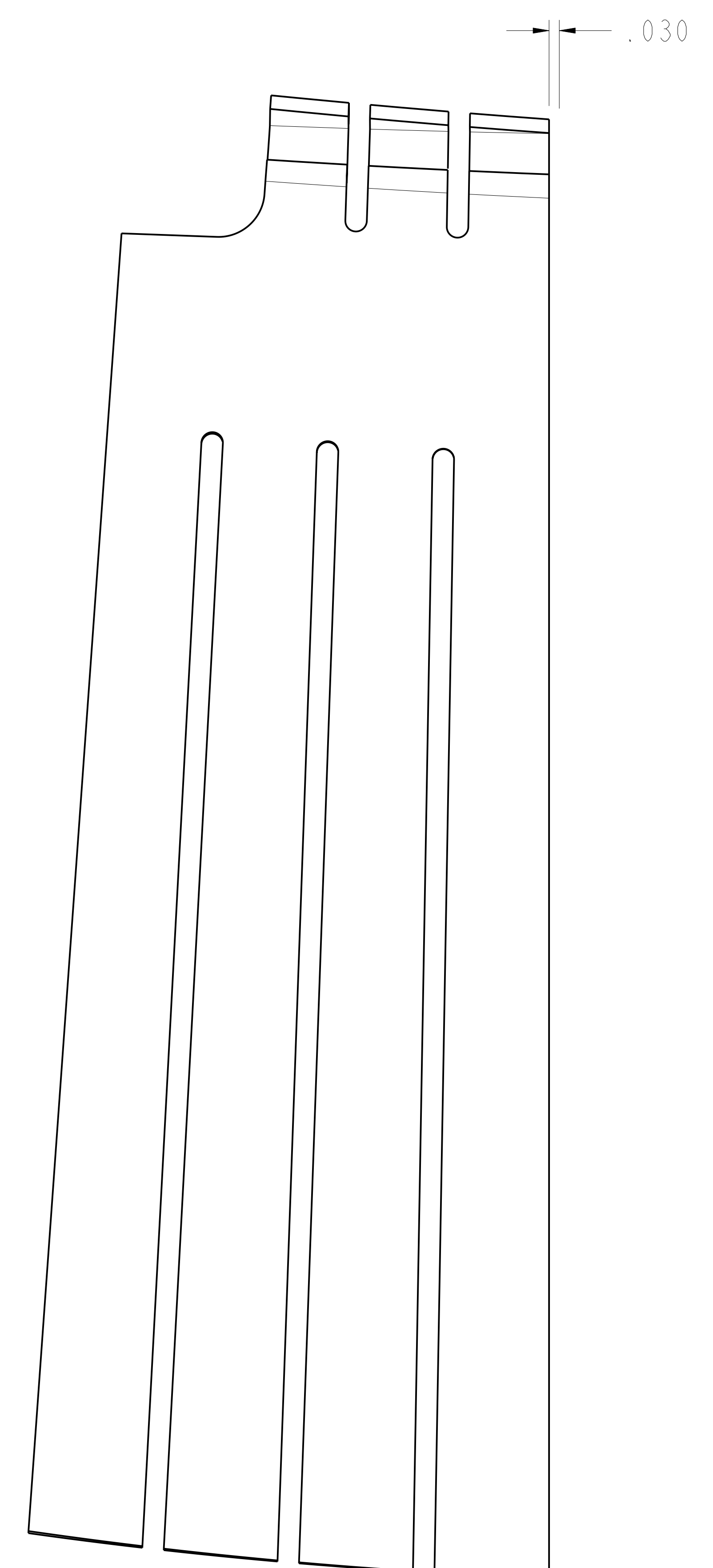

VIEW NORMAL TO MATING PART WINDING SURFACE AT WINDING CENTER LENGTH RATIO RIGHT BOUND

SE140-287-21 SHOWN  
SEE DRAWING SE140-287 FOR FLAT DEVELOPMENTS  
PART DETAILS TYPICAL OF ODD DASH NUMBERS  
EVEN DASH NUMBERS OPPOSITE

Oak Ridge National Laboratory managed for the DEPARTMENT OF ENERGY under U.S. GOVERNMENT contract DE-AC05-00OR22725 UT-BATTELLE, LLC, Oak Ridge, Tennessee PROJECT NAME:						
<b>UT-BATTELLE</b> NATIONAL COMPACT STELLARATOR EXPERIMENT						
RACETRACK SIDE 1 WEB COPPER CLADDING FABRICATED INSTALLATION						
VERSION NO:	PLANT	BLDG	FL	SHT	OF	TYPE CLASS
2+		5700	3	5	5	U
RELEASE LEVEL		SE140-283			REV	
Fabrication					0	

SE140-283

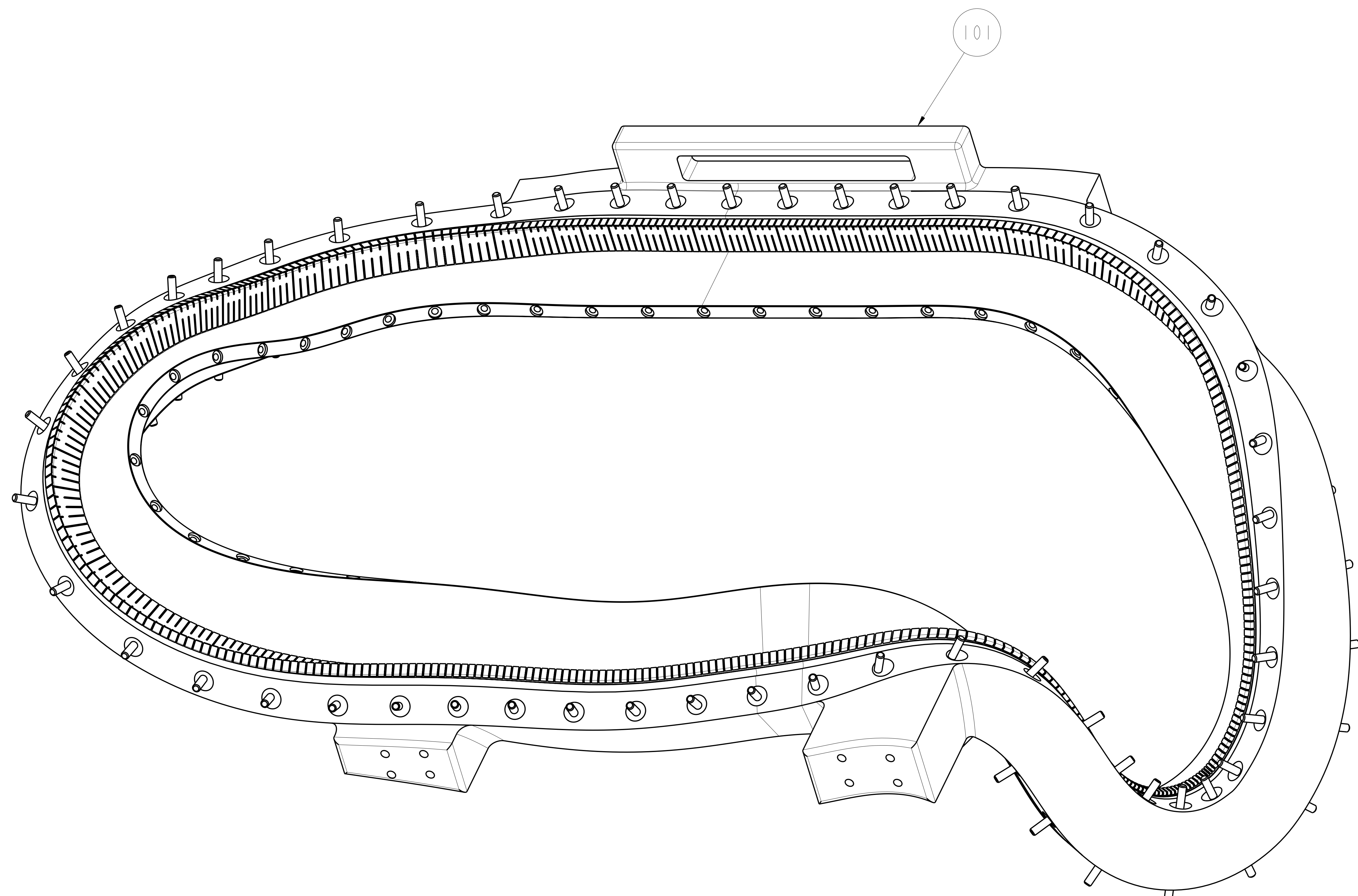

-1 SIDE 2 FLANGE COPPER CLADDING  
 FABRICATED INSTALLATION  
 REVERSE TRIMETRIC VIEW  
 SCALE 0.38

CAGE CODE	PART OR IDENTIFYING NO	NOMENCLATURE OR DESCRIPTION	MATERIAL	SPECIFICATION	FIND NO	WEIGHT
I	SE140-288-90	SIDE 2 FLANGE FORMED CLAD # 90	COPPER	0.0502	90	0.0502
I	SE140-288-89	SIDE 2 FLANGE FORMED CLAD # 89	COPPER	0.0504	89	0.0504
I	SE140-288-88	SIDE 2 FLANGE FORMED CLAD # 88	COPPER	0.0494	88	0.0494
I	SE140-288-87	SIDE 2 FLANGE FORMED CLAD # 87	COPPER	0.0469	87	0.0469
I	SE140-288-86	SIDE 2 FLANGE FORMED CLAD # 86	COPPER	0.0435	86	0.0435
I	SE140-288-85	SIDE 2 FLANGE FORMED CLAD # 85	COPPER	0.0403	85	0.0403
I	SE140-288-84	SIDE 2 FLANGE FORMED CLAD # 84	COPPER	0.0391	84	0.0391
I	SE140-288-83	SIDE 2 FLANGE FORMED CLAD # 83	COPPER	0.0400	83	0.0400
I	SE140-288-82	SIDE 2 FLANGE FORMED CLAD # 82	COPPER	0.0422	82	0.0422
I	SE140-288-81	SIDE 2 FLANGE FORMED CLAD # 81	COPPER	0.0440	81	0.0440
I	SE140-288-80	SIDE 2 FLANGE FORMED CLAD # 80	COPPER	0.0454	80	0.0454
I	SE140-288-79	SIDE 2 FLANGE FORMED CLAD # 79	COPPER	0.0469	79	0.0469
I	SE140-288-78	SIDE 2 FLANGE FORMED CLAD # 78	COPPER	0.0488	78	0.0488
I	SE140-288-77	SIDE 2 FLANGE FORMED CLAD # 77	COPPER	0.0510	77	0.0510
I	SE140-288-76	SIDE 2 FLANGE FORMED CLAD # 76	COPPER	0.0539	76	0.0539
I	SE140-288-75	SIDE 2 FLANGE FORMED CLAD # 75	COPPER	0.0571	75	0.0571
I	SE140-288-74	SIDE 2 FLANGE FORMED CLAD # 74	COPPER	0.0597	74	0.0597
I	SE140-288-73	SIDE 2 FLANGE FORMED CLAD # 73	COPPER	0.0600	73	0.0600
I	SE140-288-72	SIDE 2 FLANGE FORMED CLAD # 72	COPPER	0.0577	72	0.0577
I	SE140-288-71	SIDE 2 FLANGE FORMED CLAD # 71	COPPER	0.0538	71	0.0538
I	SE140-288-70	SIDE 2 FLANGE FORMED CLAD # 70	COPPER	0.0500	70	0.0500
I	SE140-288-69	SIDE 2 FLANGE FORMED CLAD # 69	COPPER	0.0472	69	0.0472
I	SE140-288-68	SIDE 2 FLANGE FORMED CLAD # 68	COPPER	0.0459	68	0.0459
I	SE140-288-67	SIDE 2 FLANGE FORMED CLAD # 67	COPPER	0.0454	67	0.0454
I	SE140-288-66	SIDE 2 FLANGE FORMED CLAD # 66	COPPER	0.0448	66	0.0448
I	SE140-288-65	SIDE 2 FLANGE FORMED CLAD # 65	COPPER	0.0439	65	0.0439
I	SE140-288-64	SIDE 2 FLANGE FORMED CLAD # 64	COPPER	0.0426	64	0.0426
I	SE140-288-63	SIDE 2 FLANGE FORMED CLAD # 63	COPPER	0.0412	63	0.0412
I	SE140-288-62	SIDE 2 FLANGE FORMED CLAD # 62	COPPER	0.0400	62	0.0400
I	SE140-288-61	SIDE 2 FLANGE FORMED CLAD # 61	COPPER	0.0392	61	0.0392
I	SE140-288-60	SIDE 2 FLANGE FORMED CLAD # 60	COPPER	0.0388	60	0.0388
I	SE140-288-59	SIDE 2 FLANGE FORMED CLAD # 59	COPPER	0.0388	59	0.0388
I	SE140-288-58	SIDE 2 FLANGE FORMED CLAD # 58	COPPER	0.0391	58	0.0391
I	SE140-288-57	SIDE 2 FLANGE FORMED CLAD # 57	COPPER	0.0398	57	0.0398
I	SE140-288-56	SIDE 2 FLANGE FORMED CLAD # 56	COPPER	0.0405	56	0.0405
I	SE140-288-55	SIDE 2 FLANGE FORMED CLAD # 55	COPPER	0.0409	55	0.0409
I	SE140-288-54	SIDE 2 FLANGE FORMED CLAD # 54	COPPER	0.0411	54	0.0411
I	SE140-288-53	SIDE 2 FLANGE FORMED CLAD # 53	COPPER	0.0412	53	0.0412
I	SE140-288-52	SIDE 2 FLANGE FORMED CLAD # 52	COPPER	0.0413	52	0.0413
I	SE140-288-51	SIDE 2 FLANGE FORMED CLAD # 51	COPPER	0.0413	51	0.0413
I	SE140-288-50	SIDE 2 FLANGE GENERIC CLAD # 50	COPPER	0.0413	50	0.0413
I	SE140-288-49	SIDE 2 FLANGE FORMED CLAD # 49	COPPER	0.0414	49	0.0414
I	SE140-288-48	SIDE 2 FLANGE FORMED CLAD # 48	COPPER	0.0419	48	0.0419
I	SE140-288-47	SIDE 2 FLANGE FORMED CLAD # 47	COPPER	0.0428	47	0.0428
I	SE140-288-46	SIDE 2 FLANGE FORMED CLAD # 46	COPPER	0.0443	46	0.0443
I	SE140-288-45	SIDE 2 FLANGE FORMED CLAD # 45	COPPER	0.0466	45	0.0466
I	SE140-288-44	SIDE 2 FLANGE FORMED CLAD # 44	COPPER	0.0497	44	0.0497
I	SE140-288-43	SIDE 2 FLANGE FORMED CLAD # 43	COPPER	0.0526	43	0.0526
I	SE140-288-42	SIDE 2 FLANGE FORMED CLAD # 42	COPPER	0.0531	42	0.0531
I	SE140-288-41	SIDE 2 FLANGE FORMED CLAD # 41	COPPER	0.0497	41	0.0497
I	SE140-288-40	SIDE 2 FLANGE FORMED CLAD # 40	COPPER	0.0437	40	0.0437
I	SE140-288-39	SIDE 2 FLANGE FORMED CLAD # 39	COPPER	0.0378	39	0.0378
I	SE140-288-38	SIDE 2 FLANGE FORMED CLAD # 38	COPPER	0.0333	38	0.0333
I	SE140-288-37	SIDE 2 FLANGE FORMED CLAD # 37	COPPER	0.0304	37	0.0304
I	SE140-288-36	SIDE 2 FLANGE FORMED CLAD # 36	COPPER	0.0285	36	0.0285
I	SE140-288-35	SIDE 2 FLANGE FORMED CLAD # 35	COPPER	0.0270	35	0.0270
I	SE140-288-34	SIDE 2 FLANGE FORMED CLAD # 34	COPPER	0.0253	34	0.0253
I	SE140-288-33	SIDE 2 FLANGE FORMED CLAD # 33	COPPER	0.0253	33	0.0253
I	SE140-288-32	SIDE 2 FLANGE FORMED CLAD # 32	COPPER	0.0218	32	0.0218
I	SE140-288-31	SIDE 2 FLANGE FORMED CLAD # 31	COPPER	0.0267	31	0.0267
I	SE140-288-30	SIDE 2 FLANGE FORMED CLAD # 30	COPPER	0.0356	30	0.0356
I	SE140-288-29	SIDE 2 FLANGE FORMED CLAD # 29	COPPER	0.0369	29	0.0369
I	SE140-288-28	SIDE 2 FLANGE FORMED CLAD # 28	COPPER	0.0397	28	0.0397
I	SE140-288-27	SIDE 2 FLANGE FORMED CLAD # 27	COPPER	0.0414	27	0.0414
I	SE140-288-26	SIDE 2 FLANGE FORMED CLAD # 26	COPPER	0.0426	26	0.0426
I	SE140-288-25	SIDE 2 FLANGE FORMED CLAD # 25	COPPER	0.0432	25	0.0432
I	SE140-288-24	SIDE 2 FLANGE FORMED CLAD # 24	COPPER	0.0435	24	0.0435
I	SE140-288-23	SIDE 2 FLANGE FORMED CLAD # 23	COPPER	0.0438	23	0.0438
I	SE140-288-22	SIDE 2 FLANGE FORMED CLAD # 22	COPPER	0.0443	22	0.0443
I	SE140-288-21	SIDE 2 FLANGE FORMED CLAD # 21	COPPER	0.0450	21	0.0450
I	SE140-288-20	SIDE 2 FLANGE FORMED CLAD # 20	COPPER	0.0456	20	0.0456
I	SE140-288-19	SIDE 2 FLANGE FORMED CLAD # 19	COPPER	0.0460	19	0.0460
I	SE140-288-18	SIDE 2 FLANGE FORMED CLAD # 18	COPPER	0.0467	18	0.0467
I	SE140-288-17	SIDE 2 FLANGE FORMED CLAD # 17	COPPER	0.0477	17	0.0477
I	SE140-288-16	SIDE 2 FLANGE FORMED CLAD # 16	COPPER	0.0488	16	0.0488
I	SE140-288-15	SIDE 2 FLANGE FORMED CLAD # 15	COPPER	0.0499	15	0.0499
I	SE140-288-14	SIDE 2 FLANGE FORMED CLAD # 14	COPPER	0.0507	14	0.0507
I	SE140-288-13	SIDE 2 FLANGE FORMED CLAD # 13	COPPER	0.0513	13	0.0513
I	SE140-288-12	SIDE 2 FLANGE FORMED CLAD # 12	COPPER	0.0508	12	0.0508
I	SE140-288-11	SIDE 2 FLANGE FORMED CLAD # 11	COPPER	0.0487	11	0.0487
I	SE140-288-10	SIDE 2 FLANGE FORMED CLAD # 10	COPPER	0.0456	10	0.0456
I	SE140-288-9	SIDE 2 FLANGE FORMED CLAD # 9	COPPER	0.0427	9	0.0427
I	SE140-288-8	SIDE 2 FLANGE FORMED CLAD # 8	COPPER	0.0407	8	0.0407
I	SE140-288-7	SIDE 2 FLANGE FORMED CLAD # 7	COPPER	0.0398	7	0.0398
I	SE140-288-6	SIDE 2 FLANGE FORMED CLAD # 6	COPPER	0.0397	6	0.0397
I	SE140-288-5	SIDE 2 FLANGE FORMED CLAD # 5	COPPER	0.0398	5	0.0398
I	SE140-288-4	SIDE 2 FLANGE FORMED CLAD # 4	COPPER	0.0400	4	0.0400
I	SE140-288-3	SIDE 2 FLANGE FORMED CLAD # 3	COPPER	0.0401	3	0.0401
I	SE140-288-2	SIDE 2 FLANGE FORMED CLAD # 2	COPPER	0.0401	2	0.0401
I	SE140-288-1	SIDE 2 FLANGE FORMED CLAD # 1	COPPER	0.0400	1	0.0400
I	SE140-183-1	SIDE 2 FLG COPPER CLAD FAB INSTALL	--	4.0148	--	4.0148

CAGE CODE	PART OR IDENTIFYING NO	NOMENCLATURE OR DESCRIPTION	MATERIAL	SPECIFICATION	FIND NO
I	SE1406-011	TWISTED RACETRACK WINDING FORM WLDMT	STEEL	730.0000	101
I	SE140-288-100	SIDE 2 FLANGE FORMED CLAD # 100	COPPER	0.0399	100
I	SE140-288-99	SIDE 2 FLANGE FORMED CLAD # 99	COPPER	0.0397	99
I	SE140-288-98	SIDE 2 FLANGE FORMED CLAD # 98	COPPER	0.0399	98
I	SE140-288-97	SIDE 2 FLANGE FORMED CLAD # 97	COPPER	0.0404	97
I	SE140-288-96	SIDE 2 FLANGE FORMED CLAD # 96	COPPER	0.0411	96
I	SE140-288-95	SIDE 2 FLANGE FORMED CLAD # 95	COPPER	0.0418	95
I	SE140-288-94	SIDE 2 FLANGE FORMED CLAD # 94	COPPER	0.0428	94
I	SE140-288-93	SIDE 2 FLANGE FORMED CLAD # 93	COPPER	0.0444	93
I	SE140-288-92	SIDE 2 FLANGE FORMED CLAD # 92	COPPER	0.0467	92
I	SE140-288-91	SIDE 2 FLANGE FORMED CLAD # 91	COPPER	0.0489	91

CAGE CODE	PART OR IDENTIFYING NO	NOMENCLATURE OR DESCRIPTION	MATERIAL	SPECIFICATION	FIND NO
I	SE140-288-10	SIDE 2 FLANGE FORMED CLAD # 10	COPPER	0.0456	10
I	SE140-288-9	SIDE 2 FLANGE FORMED CLAD # 9	COPPER	0.0427	9
I	SE140-288-8	SIDE 2 FLANGE FORMED CLAD # 8	COPPER	0.0407	8
I	SE140-288-7	SIDE 2 FLANGE FORMED CLAD # 7	COPPER	0.0398	7
I	SE140-288-6	SIDE 2 FLANGE FORMED CLAD # 6	COPPER	0.0397	6
I	SE140-288-5	SIDE 2 FLANGE FORMED CLAD # 5	COPPER	0.0398	5
I	SE140-288-4	SIDE 2 FLANGE FORMED CLAD # 4	COPPER	0.0400	4
I	SE140-288-3	SIDE 2 FLANGE FORMED CLAD # 3	COPPER	0.0401	3
I	SE140-288-2	SIDE 2 FLANGE FORMED CLAD # 2	COPPER	0.0401	2
I	SE140-288-1	SIDE 2 FLANGE FORMED CLAD # 1	COPPER	0.0400	1
I	SE140-183-1	SIDE 2 FLG COPPER CLAD FAB INSTALL	--	4.0148	--

**SCALE NOTED**  
 TOLERANCES UNLESS OTHERWISE SPECIFIED  
 CHK :  
 SECT :  
 DEPT :  
 PE :  
 CR :  
 PJ :  
 RD :  
 BREAK SHARP EDGES OR MAX :  
 FINISH UNLESS OTHERWISE SPECIFIED  
 PPPL DRFT :  
 VERSION NO. :  
 PLANT :  
 BLDG :  
 FL :  
 SHEET :  
 TYPE :  
 CLASS :  
 U :  
 RELEASE LEVEL :  
 Fabrication

Oak Ridge National Laboratory  
 managed for the DEPARTMENT OF ENERGY BY  
 UT-BATTELLE, LLC  
 U.S. GOVERNMENT CONTRACT DE-AC05-00OR22725  
 Oak Ridge, Tennessee

**UT-BATTELLE**  
 PROJECT 5846  
**NATIONAL COMPACT STELLARATOR EXPERIMENT**  
**TWISTED RACETRACK**  
**SIDE 2 FLANGE COPPER CLADDING**  
**FABRICATED INSTALLATION**

SEI40-284  
 REV 0

NO REPRESENTATION OR WARRANTY, EXPRESSED OR IMPLIED, IS MADE AS TO THE ACCURACY, COMPLETENESS OR USEFULNESS OF THE INFORMATION OR STATEMENTS CONTAINED IN THESE DRAWINGS, OR THAT THE USE OR DISCLOSURE OF ANY INFORMATION, APPARATUS, METHOD OR PROCESS DISCLOSED IN THESE DRAWINGS MAY NOT INFRINGE PRIVATE RIGHTS OF OTHERS. NO LIABILITY IS ASSUMED WITH RESPECT TO THE USE OF, OR FOR DAMAGES RESULTING FROM THE USE OF, ANY INFORMATION, APPARATUS, METHOD OR PROCESS DISCLOSED IN THESE DRAWINGS. DRAWINGS MADE AVAILABLE FOR INFORMATION TO BIDDER ARE NOT TO BE USED FOR OTHER PURPOSES, AND ARE TO BE RETURNED UPON REQUEST OF THE FORWARDING CONTRACTOR.

**P** THIS DRAWING PRODUCED ON PRO-ENGINEER

REV	DESCRIPTION	BY	DATE	CHK	DEPT	DATE	PE	REQ	DATE	ORNL	DOE	DATE
REVISION OR ISSUE PURPOSE												

REV	DESCRIPTION	BY	DATE	CHK	DEPT	DATE	PE	REQ	DATE	ORNL	DOE	DATE
REVISION OR ISSUE PURPOSE												

REV	DESCRIPTION	BY	DATE	CHK	DEPT	DATE	PE	REQ	DATE	ORNL	DOE	DATE
REVISION OR ISSUE PURPOSE												

REV	DESCRIPTION	BY	DATE	CHK	DEPT	DATE	PE	REQ	DATE	ORNL	DOE	DATE
REVISION OR ISSUE PURPOSE												

8

7

6

5

4

3

2

1

NEXT ASS'Y:

FINAL ASS'Y:

H

H

G

G

F

F

E

E

D

D

C

C

B

B

A

A

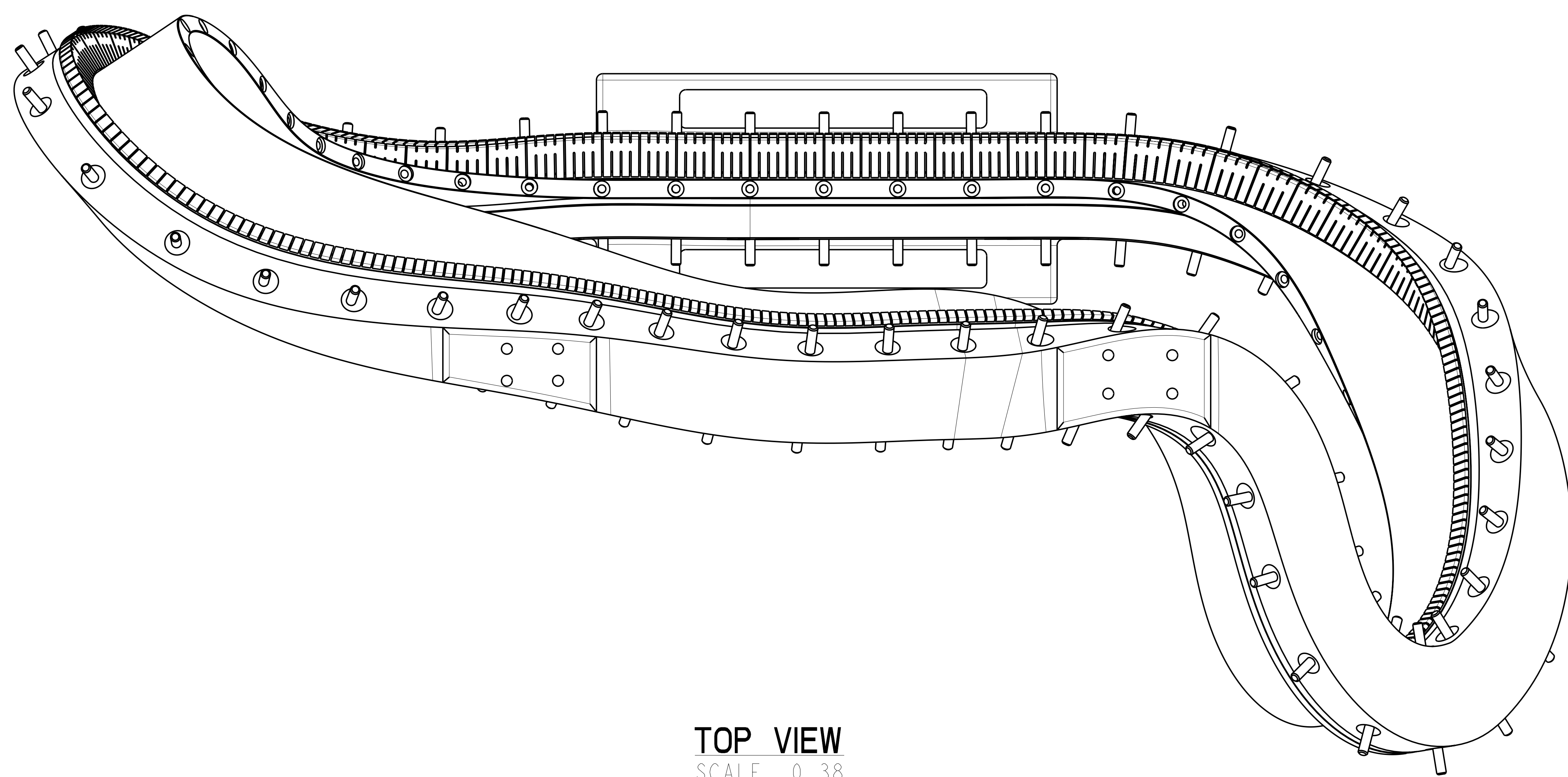
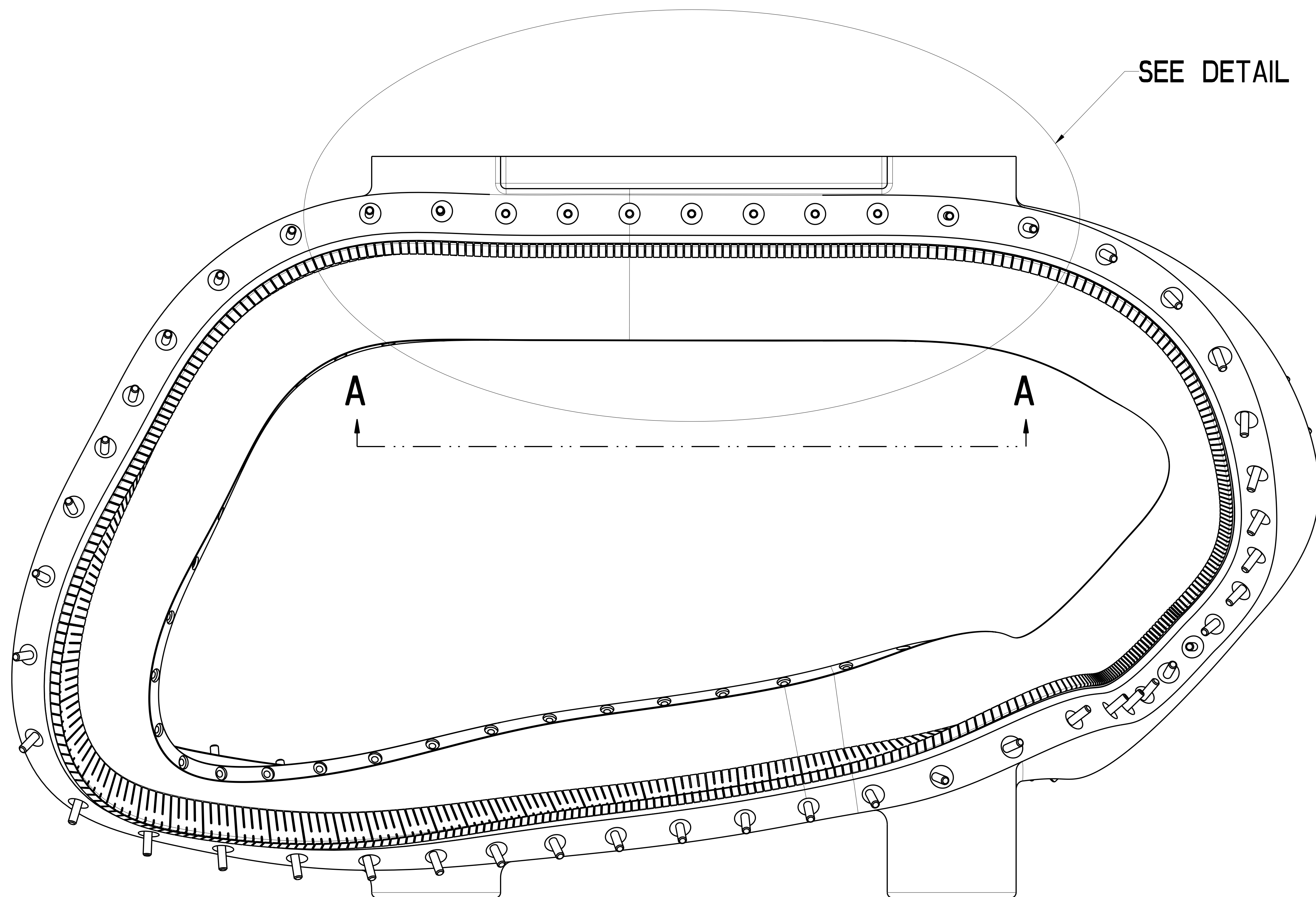

TOP VIEW  
SCALE 0.38

Oak Ridge National Laboratory managed for the DEPARTMENT OF ENERGY under U.S. GOVERNMENT contract DE-AC05-00OR22725 UT-BATTELLE, LLC, Oak Ridge, Tennessee <small>PROJECT NAME</small>						
<b>UT-BATTELLE</b> <b>NATIONAL COMPACT STELLARATOR EXPERIMENT</b>						
<b>TWISTED RACETRACK          SIDE 2 FLANGE COPPER CLADDING          FABRICATED INSTALLATION</b>						
VERSION NO:	PLANT	BLDG	FL	SHT	OF	TYPE CLASS
2+		5700	3	2	4	U
RELEASE LEVEL		SE140-284			REV	
Fabrication					0	

8

7

6

5

4

3

2

1

82-140-284

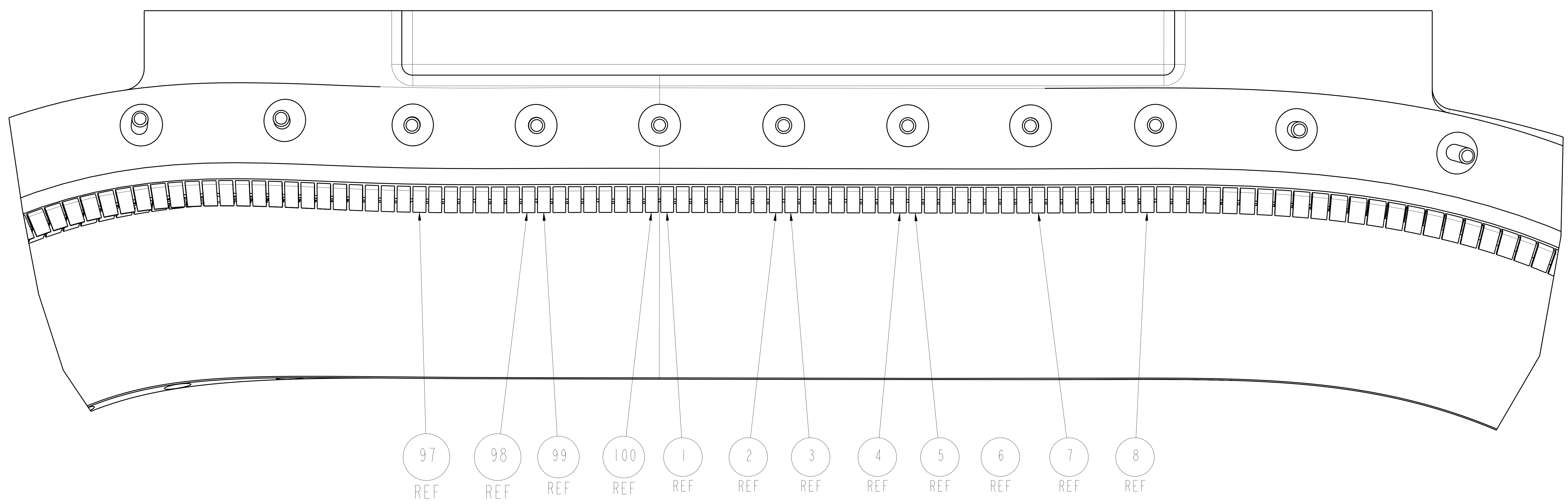

DETAIL A  
SCALE 1.000

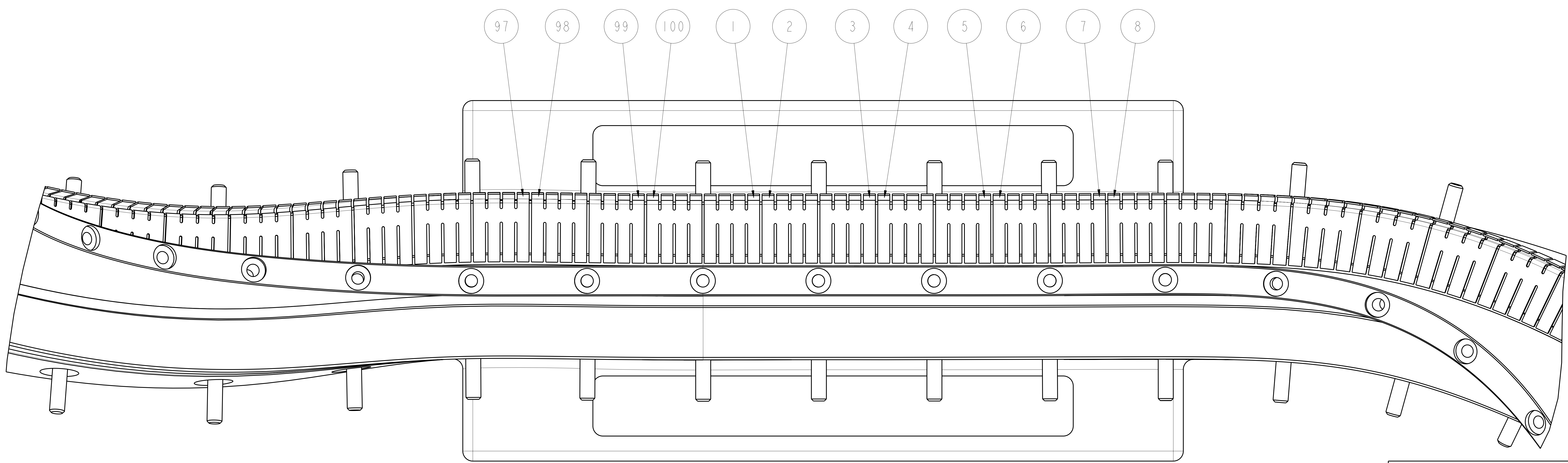

SECTION A-A

Oak Ridge National Laboratory managed for the DEPARTMENT OF ENERGY under U.S. GOVERNMENT contract DE-AC05-00OR22725 UT-BATTELLE, LLC, Oak Ridge, Tennessee PROJECT NAME:						
<b>UT-BATTELLE</b> <b>NATIONAL COMPACT STELLARATOR EXPERIMENT</b>						
<b>TWISTED RACETRACK          SIDE 2 FLANGE COPPER CLADDING          FABRICATED INSTALLATION</b>						
VERSION NO: 2+	PLANT	BLDG 5700	FL 3	SHT 3	OF 4	TYPE CLASS U
RELEASE LEVEL Fabrication		SE140-284			REV 0	

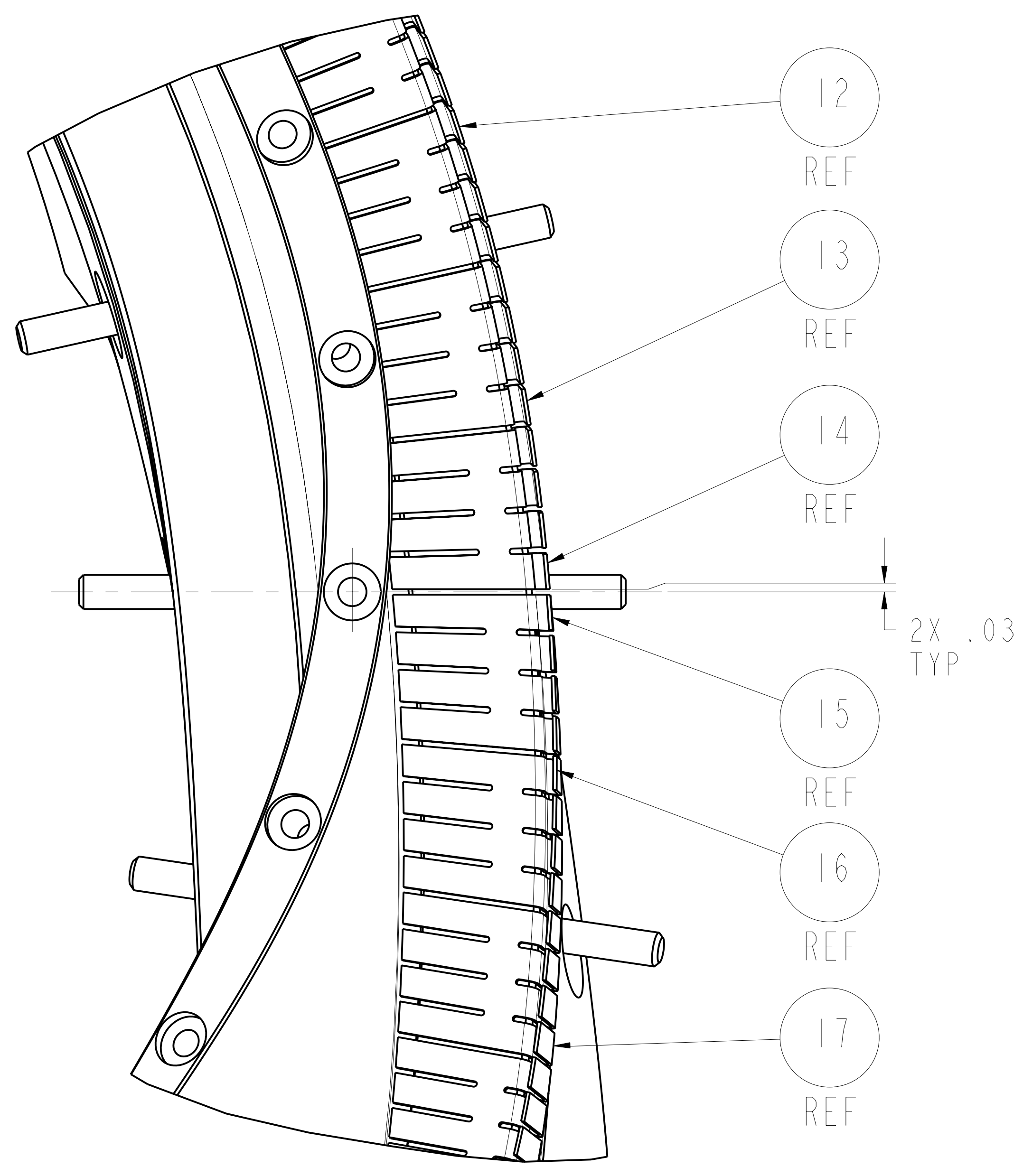

SECTION C-C

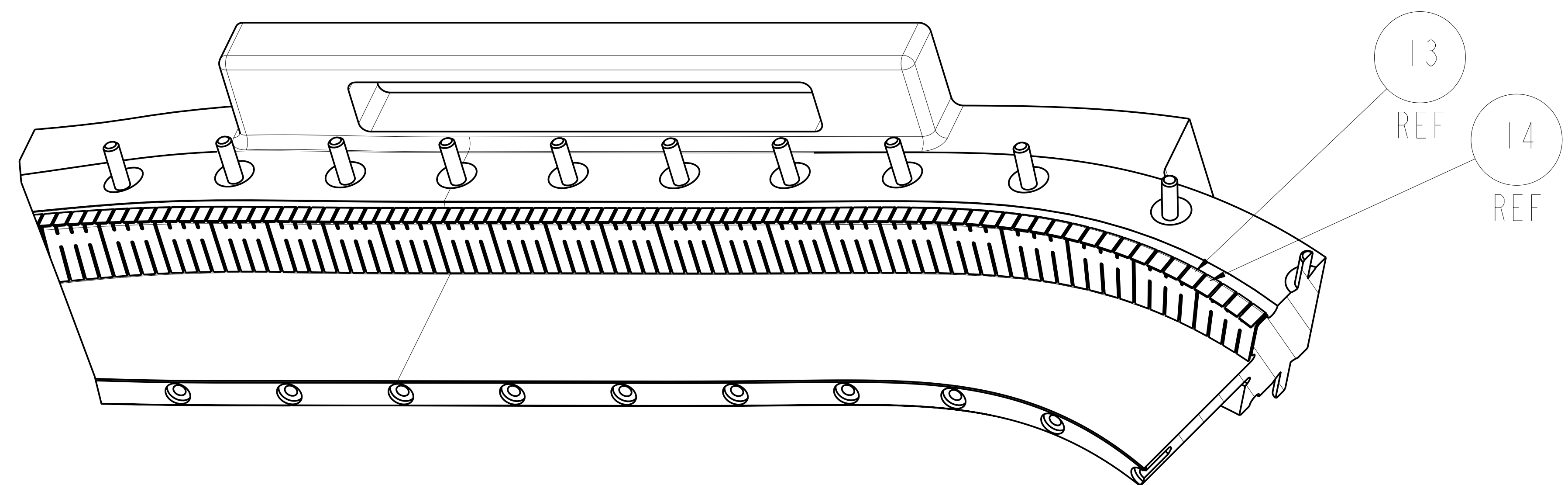

SECTION B-B  
 SCALE 0.50

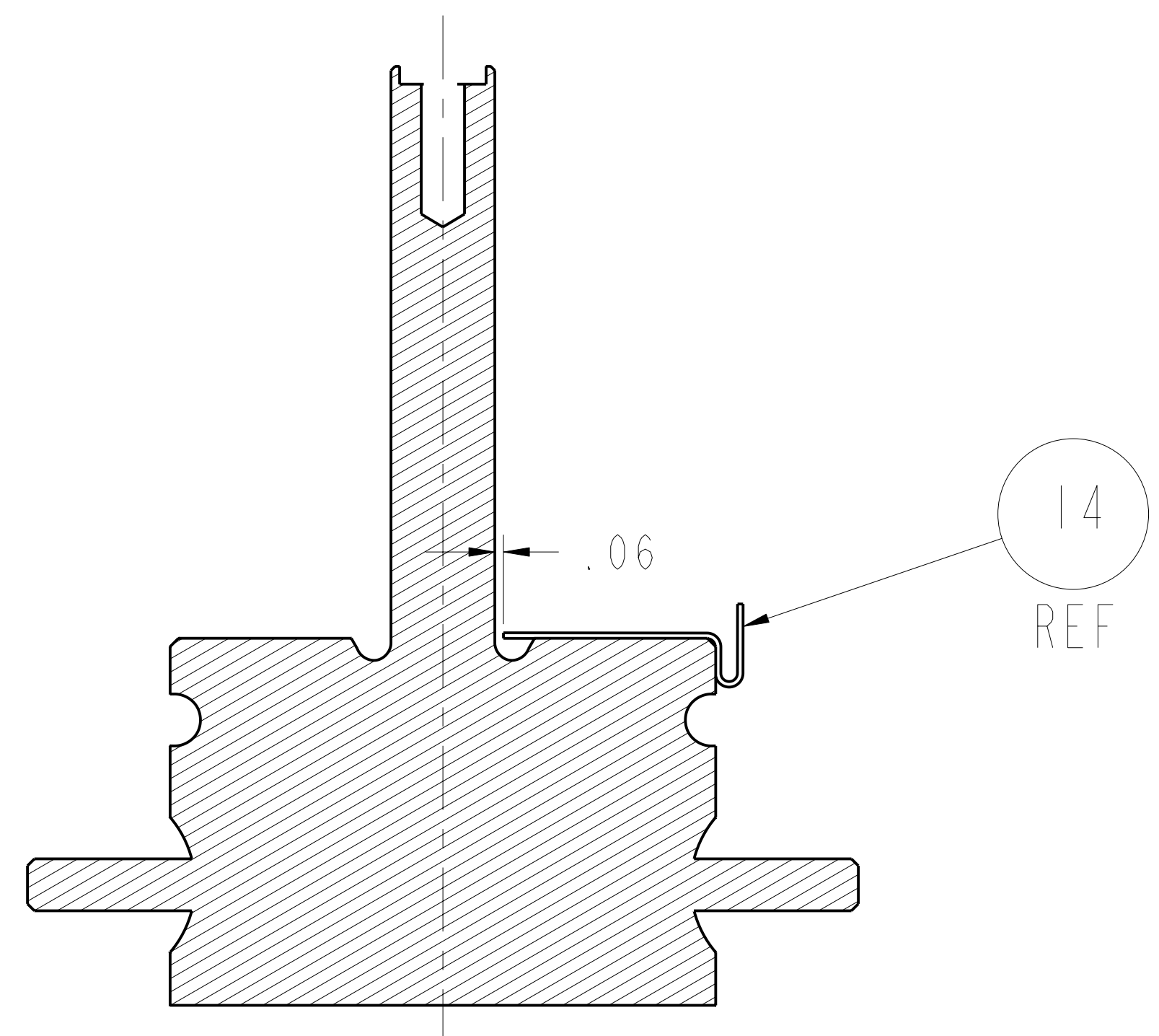

SECTION B-B

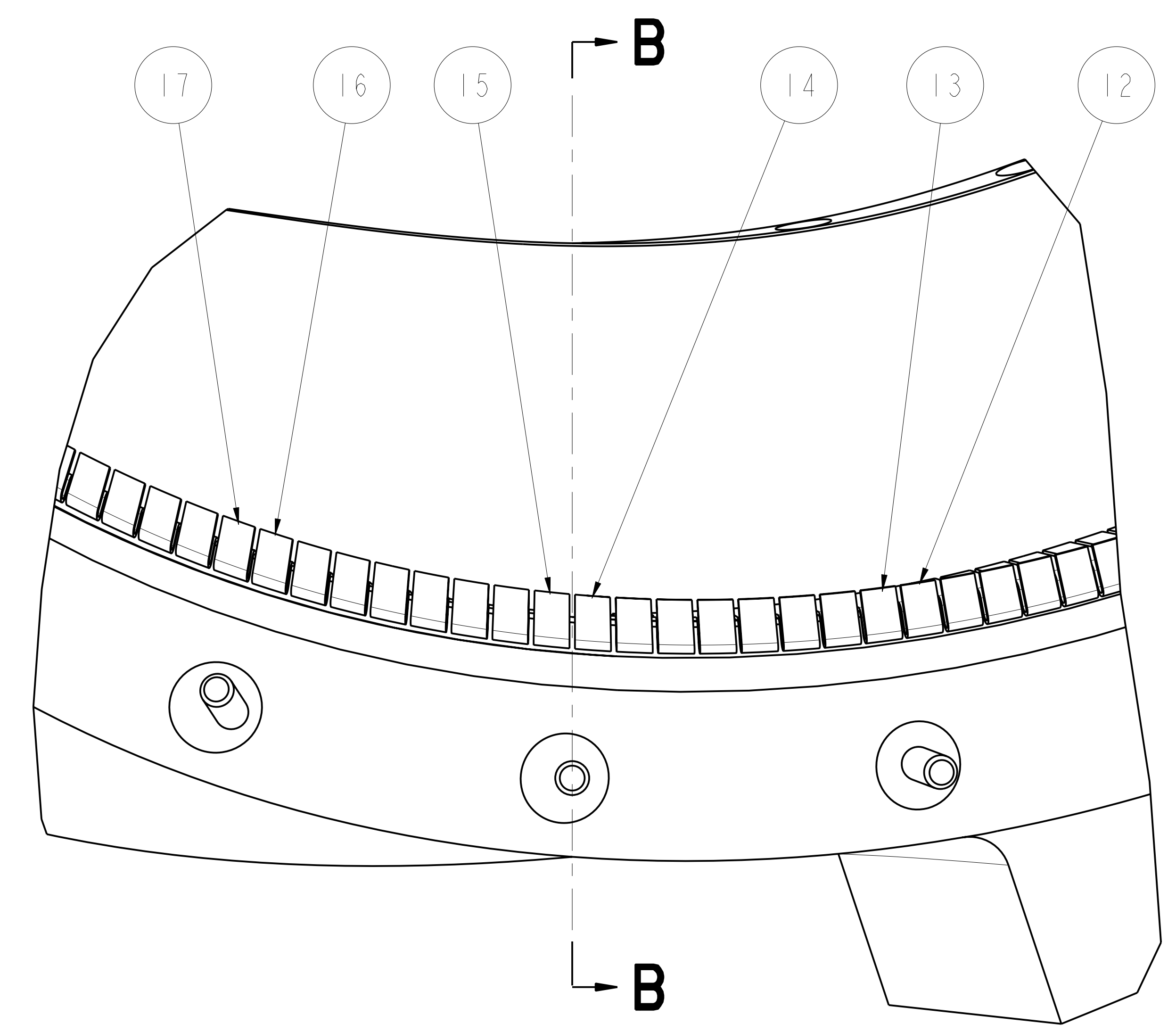

VIEW PERPENDICULAR TO WINDING SURFACE AT CLAMP INTERFACE  
 SCALE 1.00

Oak Ridge National Laboratory managed for the DEPARTMENT OF ENERGY under U.S. GOVERNMENT contract DE-AC05-00OR22725 UT-BATTELLE, LLC, Oak Ridge, Tennessee PROJECT TITLE:						
<b>UT-BATTELLE</b>						
NATIONAL COMPACT STELLARATOR EXPERIMENT						
TWISTED RACETRACK SIDE 2 FLANGE COPPER CLADDING FABRICATED INSTALLATION						
VERSION NO:	PLANT	BLDG	FL	SHT	OF	TYPE CLASS
2+		5700	3	4	4	U
RELEASE LEVEL		SE 140-284			REV	
Fabrication					0	

8 7 6 5 4 3 2 1

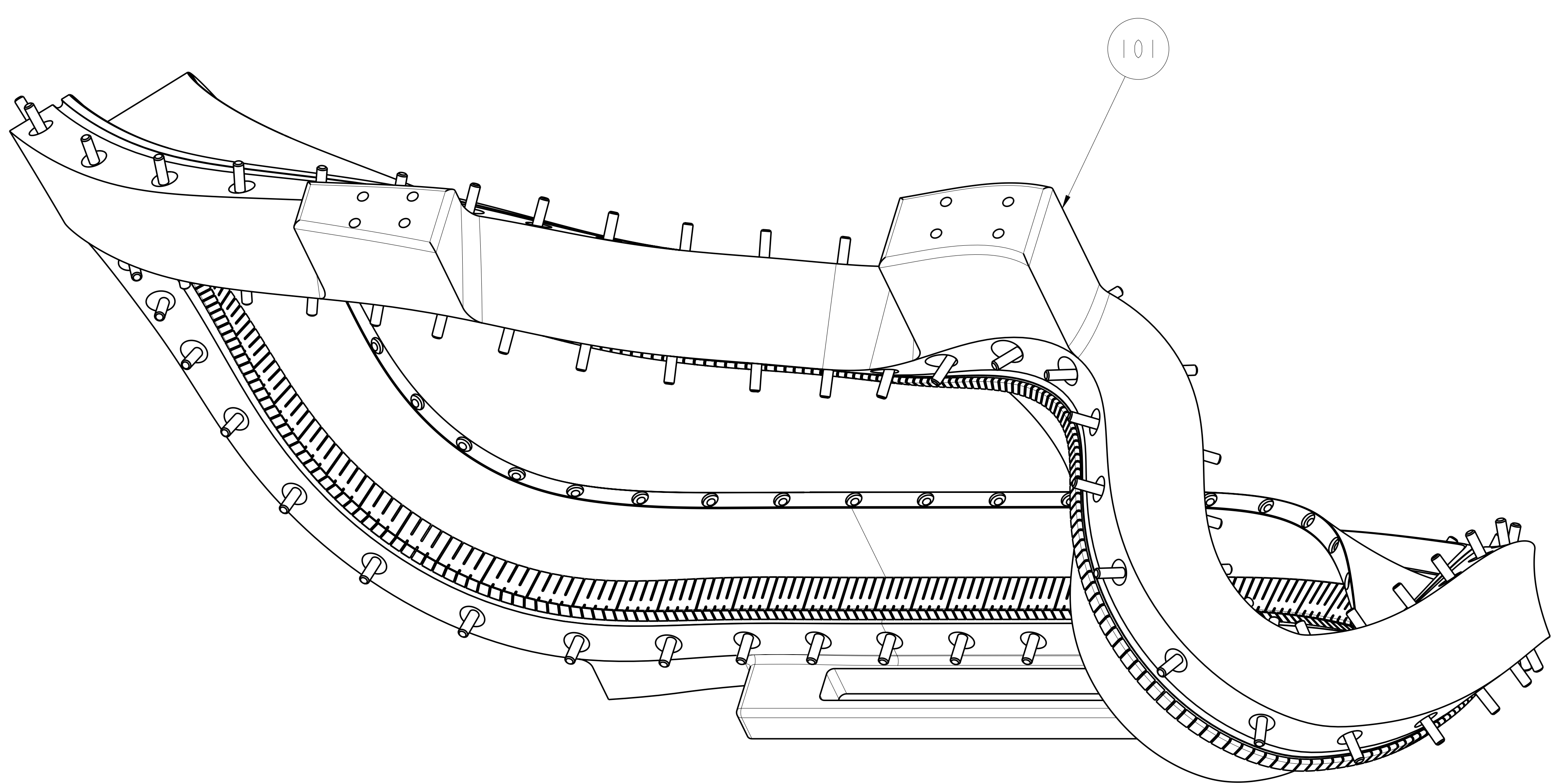

-1 SIDE I FLANGE COPPER CLADDING  
 FABRICATED INSTALLATION  
 TRIMETRIC VIEW  
 SCALE 0.38

CAGE CODE	PART OR IDENTIFYING NO	NOMENCLATURE OR DESCRIPTION	MATERIAL	SPECIFICATION	FINISH	WEIGHT	FIND NO
	SE1406-011	TWISTED RACETRACK WINDING FORM WLDMT	STEEL	730.0000	101		
I	SE140-289-100	SIDE I FLANGE, FORMED CLAD # 100	COPPER	0.0373	100		
I	SE140-289-99	SIDE I FLANGE, FORMED CLAD # 99	COPPER	0.0372	99		
I	SE140-289-98	SIDE I FLANGE, FORMED CLAD # 98	COPPER	0.0369	98		
I	SE140-289-97	SIDE I FLANGE, FORMED CLAD # 97	COPPER	0.0368	97		
I	SE140-289-96	SIDE I FLANGE, FORMED CLAD # 96	COPPER	0.0372	96		
I	SE140-289-95	SIDE I FLANGE, FORMED CLAD # 95	COPPER	0.0386	95		
I	SE140-289-94	SIDE I FLANGE, FORMED CLAD # 94	COPPER	0.0410	94		
I	SE140-289-93	SIDE I FLANGE, FORMED CLAD # 93	COPPER	0.0442	93		
I	SE140-289-92	SIDE I FLANGE, FORMED CLAD # 92	COPPER	0.0470	92		
I	SE140-289-91	SIDE I FLANGE, FORMED CLAD # 91	COPPER	0.0483	91		

CAGE CODE	PART OR IDENTIFYING NO	NOMENCLATURE OR DESCRIPTION	MATERIAL	SPECIFICATION	FINISH	WEIGHT	FIND NO
I	SE140-289-90	SIDE I FLANGE, FORMED CLAD # 90	COPPER			0.0482	90
I	SE140-289-89	SIDE I FLANGE, FORMED CLAD # 89	COPPER			0.0476	89
I	SE140-289-88	SIDE I FLANGE, FORMED CLAD # 88	COPPER			0.0470	88
I	SE140-289-87	SIDE I FLANGE, FORMED CLAD # 87	COPPER			0.0462	87
I	SE140-289-86	SIDE I FLANGE, FORMED CLAD # 86	COPPER			0.0450	86
I	SE140-289-85	SIDE I FLANGE, FORMED CLAD # 85	COPPER			0.0431	85
I	SE140-289-84	SIDE I FLANGE, FORMED CLAD # 84	COPPER			0.0403	84
I	SE140-289-83	SIDE I FLANGE, FORMED CLAD # 83	COPPER			0.0367	83
I	SE140-289-82	SIDE I FLANGE, FORMED CLAD # 82	COPPER			0.0335	82
I	SE140-289-81	SIDE I FLANGE, FORMED CLAD # 81	COPPER			0.0317	81
I	SE140-289-80	SIDE I FLANGE, FORMED CLAD # 80	COPPER			0.0315	80
I	SE140-289-79	SIDE I FLANGE, FORMED CLAD # 79	COPPER			0.0319	79
I	SE140-289-78	SIDE I FLANGE, FORMED CLAD # 78	COPPER			0.0315	78
I	SE140-289-77	SIDE I FLANGE, FORMED CLAD # 77	COPPER			0.0299	77
I	SE140-289-76	SIDE I FLANGE, FORMED CLAD # 76	COPPER			0.0274	76
I	SE140-289-75	SIDE I FLANGE, FORMED CLAD # 75	COPPER			0.0263	75
I	SE140-289-74	SIDE I FLANGE, FORMED CLAD # 74	COPPER			0.0283	74
I	SE140-289-73	SIDE I FLANGE, FORMED CLAD # 73	COPPER			0.0328	73
I	SE140-289-72	SIDE I FLANGE, FORMED CLAD # 72	COPPER			0.0374	72
I	SE140-289-71	SIDE I FLANGE, FORMED CLAD # 71	COPPER			0.0406	71
I	SE140-289-70	SIDE I FLANGE, FORMED CLAD # 70	COPPER			0.0420	70
I	SE140-289-69	SIDE I FLANGE, FORMED CLAD # 69	COPPER			0.0420	69
I	SE140-289-68	SIDE I FLANGE, FORMED CLAD # 68	COPPER			0.0413	68
I	SE140-289-67	SIDE I FLANGE, FORMED CLAD # 67	COPPER			0.0403	67
I	SE140-289-66	SIDE I FLANGE, FORMED CLAD # 66	COPPER			0.0393	66
I	SE140-289-65	SIDE I FLANGE, FORMED CLAD # 65	COPPER			0.0382	65
I	SE140-289-64	SIDE I FLANGE, FORMED CLAD # 64	COPPER			0.0372	64
I	SE140-289-63	SIDE I FLANGE, FORMED CLAD # 63	COPPER			0.0362	63
I	SE140-289-62	SIDE I FLANGE, FORMED CLAD # 62	COPPER			0.0357	62
I	SE140-289-61	SIDE I FLANGE, FORMED CLAD # 61	COPPER			0.0358	61
I	SE140-289-60	SIDE I FLANGE, FORMED CLAD # 60	COPPER			0.0366	60
I	SE140-289-59	SIDE I FLANGE, FORMED CLAD # 59	COPPER			0.0381	59
I	SE140-289-58	SIDE I FLANGE, FORMED CLAD # 58	COPPER			0.0398	58
I	SE140-289-57	SIDE I FLANGE, FORMED CLAD # 57	COPPER			0.0414	57
I	SE140-289-56	SIDE I FLANGE, FORMED CLAD # 56	COPPER			0.0425	56
I	SE140-289-55	SIDE I FLANGE, FORMED CLAD # 55	COPPER			0.0426	55
I	SE140-289-54	SIDE I FLANGE, FORMED CLAD # 54	COPPER			0.0417	54
I	SE140-289-53	SIDE I FLANGE, FORMED CLAD # 53	COPPER			0.0397	53
I	SE140-289-52	SIDE I FLANGE, FORMED CLAD # 52	COPPER			0.0369	52
I	SE140-289-51	SIDE I FLANGE, FORMED CLAD # 51	COPPER			0.0341	51
I	SE140-289-50	SIDE I FLANGE, FORMED CLAD # 50	COPPER			0.0322	50
I	SE140-289-49	SIDE I FLANGE, FORMED CLAD # 49	COPPER			0.0311	49
I	SE140-289-48	SIDE I FLANGE, FORMED CLAD # 48	COPPER			0.0304	48
I	SE140-289-47	SIDE I FLANGE, FORMED CLAD # 47	COPPER			0.0300	47
I	SE140-289-46	SIDE I FLANGE, FORMED CLAD # 46	COPPER			0.0295	46
I	SE140-289-45	SIDE I FLANGE, FORMED CLAD # 45	COPPER			0.0293	45
I	SE140-289-44	SIDE I FLANGE, FORMED CLAD # 44	COPPER			0.0293	44
I	SE140-289-43	SIDE I FLANGE, FORMED CLAD # 43	COPPER			0.0300	43
I	SE140-289-42	SIDE I FLANGE, FORMED CLAD # 42	COPPER			0.0319	42
I	SE140-289-41	SIDE I FLANGE, FORMED CLAD # 41	COPPER			0.0352	41
I	SE140-289-40	SIDE I FLANGE, FORMED CLAD # 40	COPPER			0.0390	40
I	SE140-289-39	SIDE I FLANGE, FORMED CLAD # 39	COPPER			0.0426	39
I	SE140-289-38	SIDE I FLANGE, FORMED CLAD # 38	COPPER			0.0458	38
I	SE140-289-37	SIDE I FLANGE, FORMED CLAD # 37	COPPER			0.0484	37
I	SE140-289-36	SIDE I FLANGE, FORMED CLAD # 36	COPPER			0.0502	36
I	SE140-289-35	SIDE I FLANGE, FORMED CLAD # 35	COPPER			0.0511	35
I	SE140-289-34	SIDE I FLANGE, FORMED CLAD # 34	COPPER			0.0509	34
I	SE140-289-33	SIDE I FLANGE, FORMED CLAD # 33	COPPER			0.0506	33
I	SE140-289-32	SIDE I FLANGE, FORMED CLAD # 32	COPPER			0.0493	32
I	SE140-289-31	SIDE I FLANGE, FORMED CLAD # 31	COPPER			0.0483	31
I	SE140-289-30	SIDE I FLANGE, FORMED CLAD # 30	COPPER			0.0480	30
I	SE140-289-29	SIDE I FLANGE, FORMED CLAD # 29	COPPER			0.0477	29
I	SE140-289-28	SIDE I FLANGE, FORMED CLAD # 28	COPPER			0.0471	28
I	SE140-289-27	SIDE I FLANGE, FORMED CLAD # 27	COPPER			0.0462	27
I	SE140-289-26	SIDE I FLANGE, FORMED CLAD # 26	COPPER			0.0451	26
I	SE140-289-25	SIDE I FLANGE, FORMED CLAD # 25	COPPER			0.0441	25
I	SE140-289-24	SIDE I FLANGE, FORMED CLAD # 24	COPPER			0.0431	24
I	SE140-289-23	SIDE I FLANGE, FORMED CLAD # 23	COPPER			0.0425	23
I	SE140-289-22	SIDE I FLANGE, FORMED CLAD # 22	COPPER			0.0421	22
I	SE140-289-21	SIDE I FLANGE, FORMED CLAD # 21	COPPER			0.0418	21
I	SE140-289-20	SIDE I FLANGE, FORMED CLAD # 20	COPPER			0.0411	20
I	SE140-289-19	SIDE I FLANGE, FORMED CLAD # 19	COPPER			0.0404	19
I	SE140-289-18	SIDE I FLANGE, FORMED CLAD # 18	COPPER			0.0397	18
I	SE140-289-17	SIDE I FLANGE, FORMED CLAD # 17	COPPER			0.0391	17
I	SE140-289-16	SIDE I FLANGE, FORMED CLAD # 16	COPPER			0.0384	16
I	SE140-289-15	SIDE I FLANGE, FORMED CLAD # 15	COPPER			0.0379	15
I	SE140-289-14	SIDE I FLANGE, FORMED CLAD # 14	COPPER			0.0374	14
I	SE140-289-13	SIDE I FLANGE, FORMED CLAD # 13	COPPER			0.0371	13
I	SE140-289-12	SIDE I FLANGE, FORMED CLAD # 12	COPPER			0.0369	12
I	SE140-289-11	SIDE I FLANGE, FORMED CLAD # 11	COPPER			0.0369	11
I	SE140-289-10	SIDE I FLANGE, FORMED CLAD # 10	COPPER			0.0370	10
I	SE140-289-9	SIDE I FLANGE, FORMED CLAD # 9	COPPER			0.0371	9
I	SE140-289-8	SIDE I FLANGE, FORMED CLAD # 8	COPPER			0.0371	8
I	SE140-289-7	SIDE I FLANGE, FORMED CLAD # 7	COPPER			0.0372	7
I	SE140-289-6	SIDE I FLANGE, FORMED CLAD # 6	COPPER			0.0371	6
I	SE140-289-5	SIDE I FLANGE, FORMED CLAD # 5	COPPER			0.0372	5
I	SE140-289-4	SIDE I FLANGE, FORMED CLAD # 4	COPPER			0.0371	4
I	SE140-289-3	SIDE I FLANGE, FORMED CLAD # 3	COPPER			0.0372	3
I	SE140-289-2	SIDE I FLANGE, FORMED CLAD # 2	COPPER			0.0371	2
I	SE140-289-1	SIDE I FLANGE, FORMED CLAD # 1	COPPER			0.0372	1
I	SE140-285-1	SIDE I FLG, COPPER CLAD, FAB INSTALL				3.9119	

← next ass'y

← next ass'y

PARTS LIST

PARTS LIST

NO REPRESENTATION OR WARRANTY, EXPRESSED OR IMPLIED, IS MADE AS TO THE ACCURACY, COMPLETENESS OR USEFULNESS OF THE INFORMATION OR STATEMENTS CONTAINED IN THESE DRAWINGS, OR THAT THE USE OR DISCLOSURE OF ANY INFORMATION, APPARATUS, METHOD OR PROCESS DISCLOSED IN THESE DRAWINGS MAY NOT INFRINGE PRIVATE RIGHTS OF OTHERS. NO LIABILITY IS ASSUMED WITH RESPECT TO THE USE OF, OR FOR DAMAGES RESULTING FROM THE USE OF, ANY INFORMATION, APPARATUS, METHOD OR PROCESS DISCLOSED IN THESE DRAWINGS. DRAWINGS MADE AVAILABLE FOR INFORMATION TO BIDDER ARE NOT TO BE USED FOR OTHER PURPOSES, AND ARE TO BE RETURNED UPON REQUEST OF THE FORWARDING CONTRACTOR.

**P** THIS DRAWING PRODUCED ON PRO-ENGINEER

REV	DESCRIPTION	BY	DATE	CHK	DEPT	DATE	PE	REQ	DATE	ORNL	DOE	DATE

DES	BRAD NELSON	02/10/04
DRW	TOM HARGROVE	02/10/04
CHK		
SECT		
DEPT		
PE		
CR		
PJ		
REG		
FINISH	UNLESS OTHERWISE SPECIFIED	
PPPL	DRFT	
VERSION NO.	2+	
PLANT	5700	
FL	3	
SHT	1	
TYPE	4	
CLASS	U	
RELEASE LEVEL	Fabrication	
SEI40-285		
REV	0	

**UT-BATTELLE**  
 NATIONAL COMPACT STELLARATOR EXPERIMENT  
 TWISTED RACETRACK  
 SIDE I FLANGE, COPPER CLADDING  
 FABRICATED INSTALLATION

B SEI40-285

8

7

6

5

4

3

2

1

NEXT ASS'Y: 1 FINAL ASS'Y:

H

H

G

G

F

F

E

E

D

D

C

C

B

B

A

A

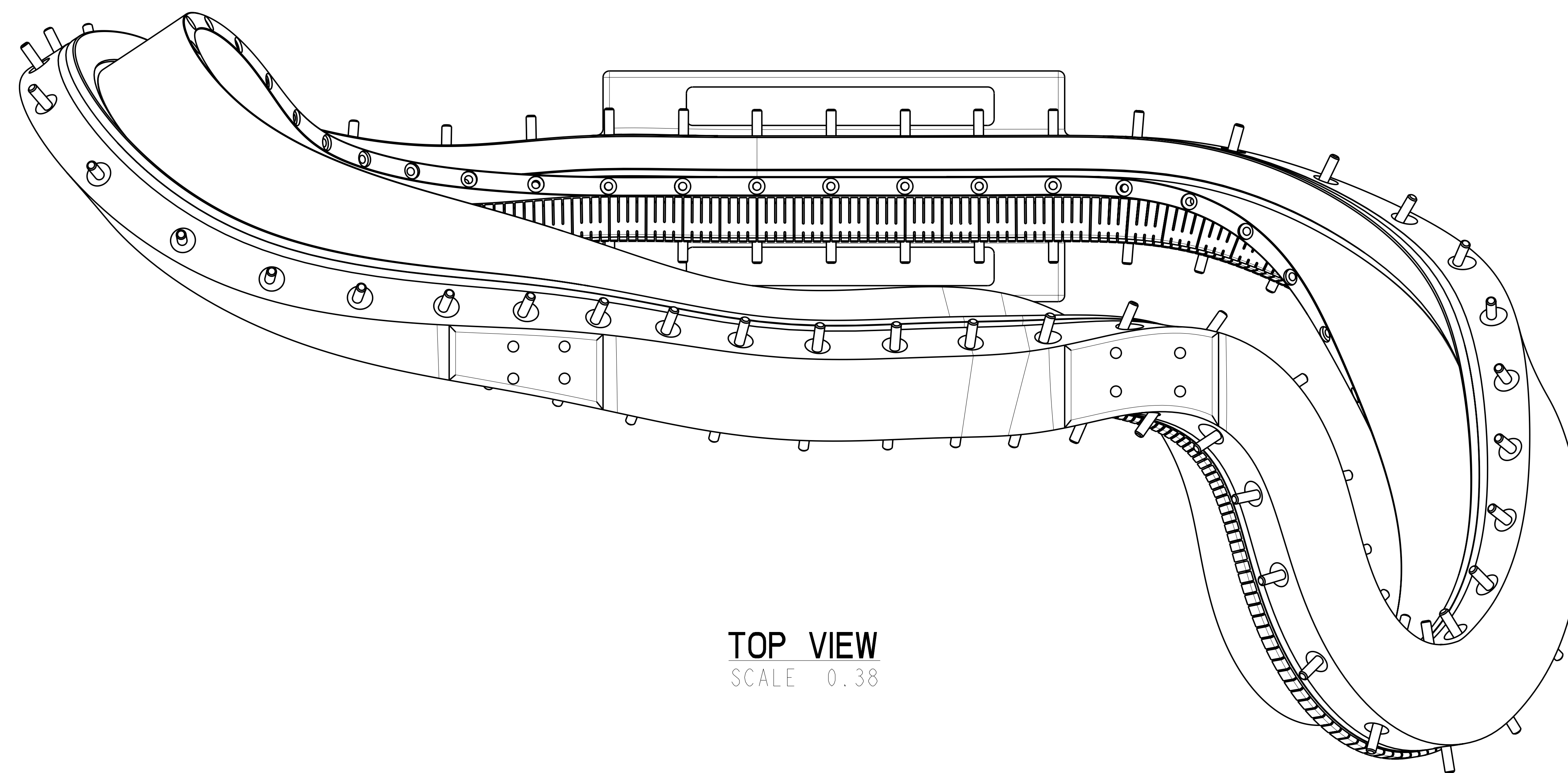

TOP VIEW  
SCALE 0.38

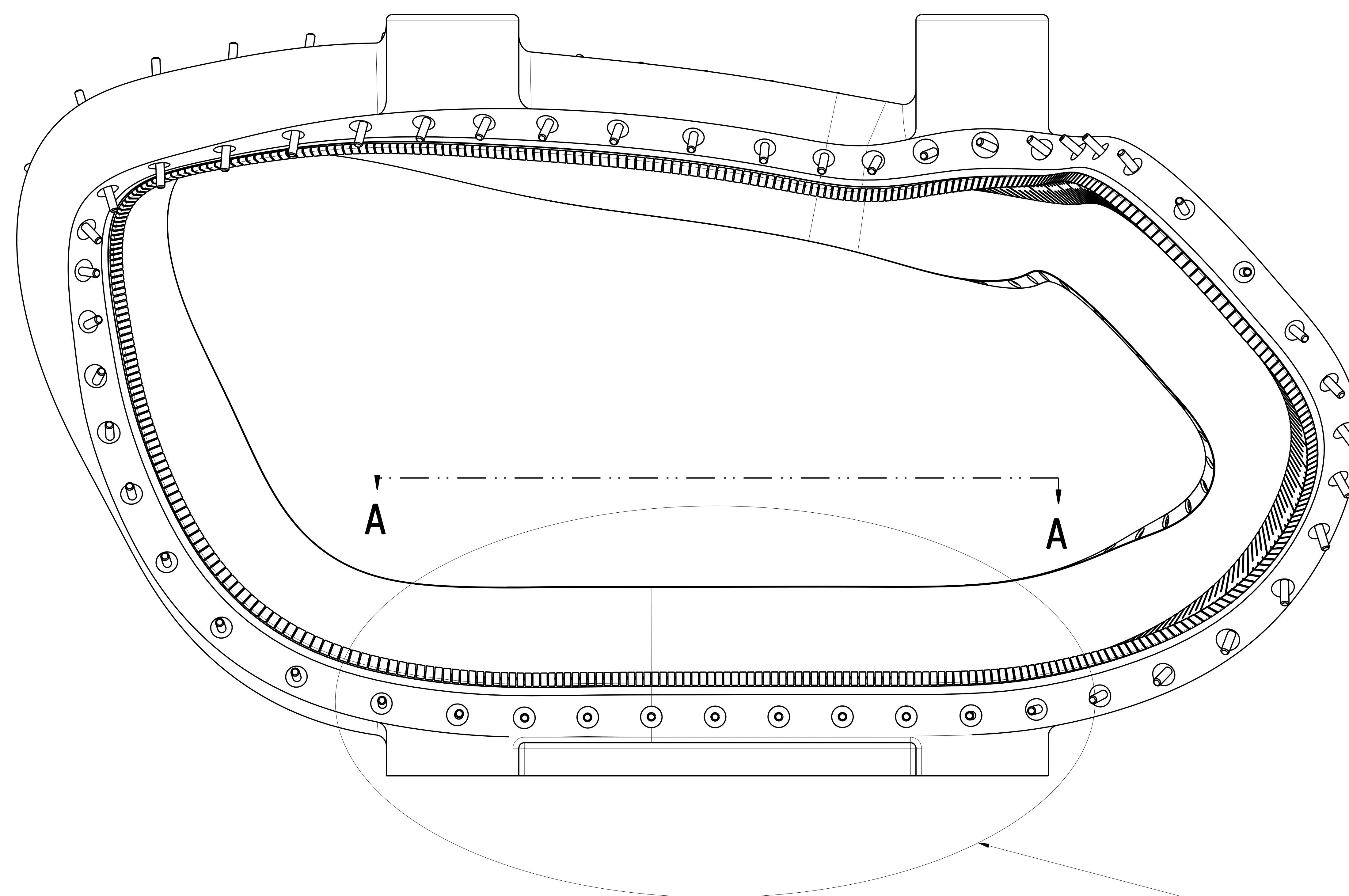

SEE DETAIL A

Oak Ridge National Laboratory managed for the DEPARTMENT OF ENERGY under U.S. GOVERNMENT contract DE-AC05-00OR22725 UT-BATTELLE, LLC, Oak Ridge, Tennessee PROJECT NAME:						
<b>UT-BATTELLE</b> <b>NATIONAL COMPACT STELLARATOR EXPERIMENT</b>						
<b>TWISTED RACETRACK          SIDE 1 FLANGE, COPPER CLADDING          FABRICATED INSTALLATION</b>						
VERSION NO:	PLANT	BLDG	FL	SHT	OF	TYPE CLASS
2+		5700	3	2	4	U
RELEASE LEVEL		SE140-285			REV	
Fabrication					0	

8

7

6

5

4

3

2

1

8

7

6

5

4

3

2

1

NEXT ASS'Y: 1 FINAL ASS'Y:

H

H

G

G

F

F

E

E

D

D

C

C

B

B

A

A

082-140-285  
082-140-285

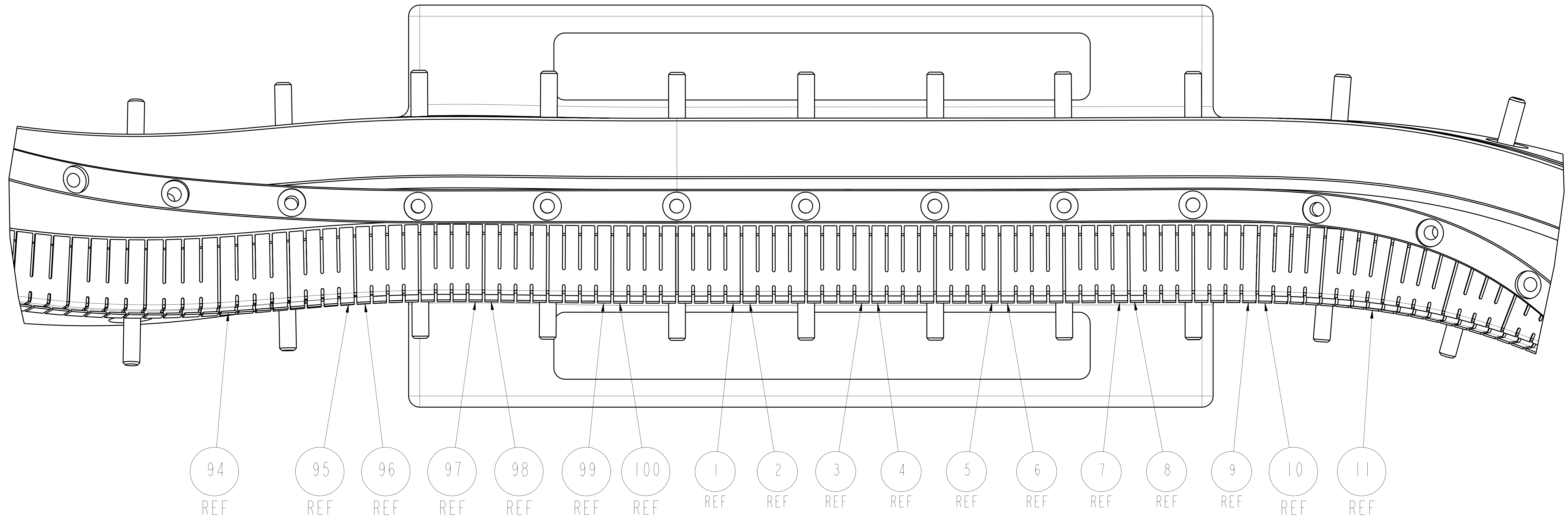

SECTION A-A

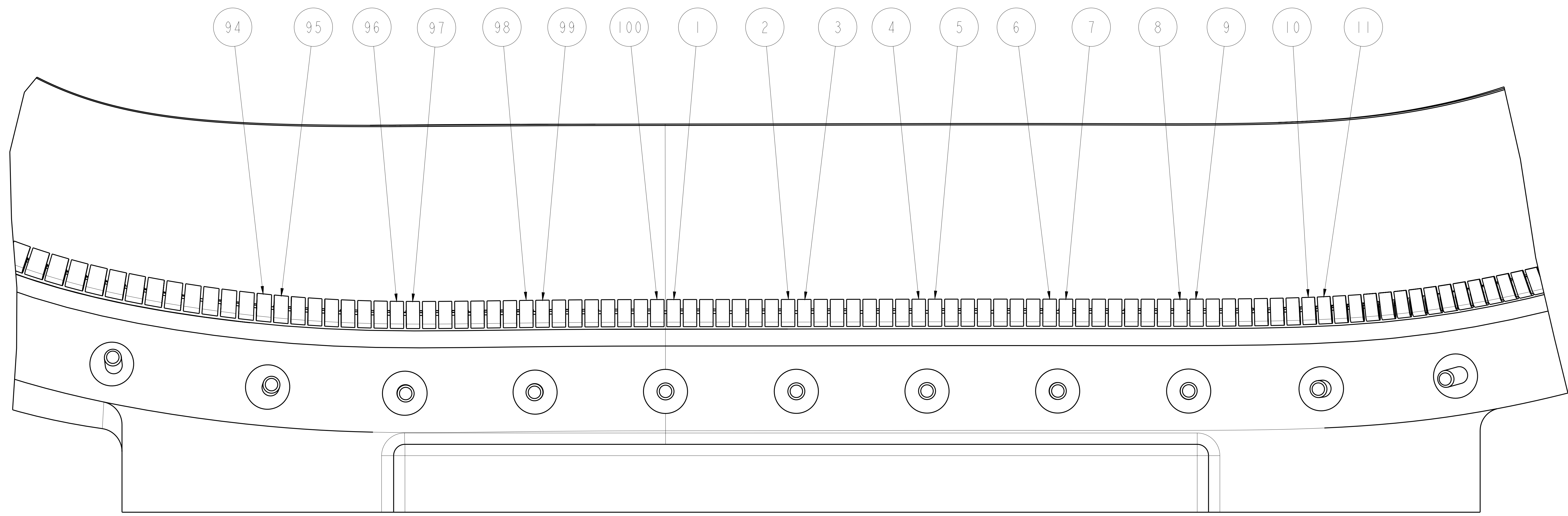

DETAIL A  
SCALE 1.00

Oak Ridge National Laboratory managed for the DEPARTMENT OF ENERGY under U.S. GOVERNMENT contract DE-AC05-00OR22725 UT-BATTELLE, LLC, Oak Ridge, Tennessee PROJECT NAME:							
<b>UT-BATTELLE</b>							
<b>NATIONAL COMPACT STELLARATOR EXPERIMENT</b>							
<b>TWISTED RACETRACK          SIDE I FLANGE, COPPER CLADDING          FABRICATED INSTALLATION</b>							
VERSION NO: 2+	PLANT	BLDG	FL	SHT	OF	TYPE	CLASS
RELEASE LEVEL Fabrication		5700	3	3	4	U	REV 0
SE140-285							1

8

7

6

5

4

3

2

1



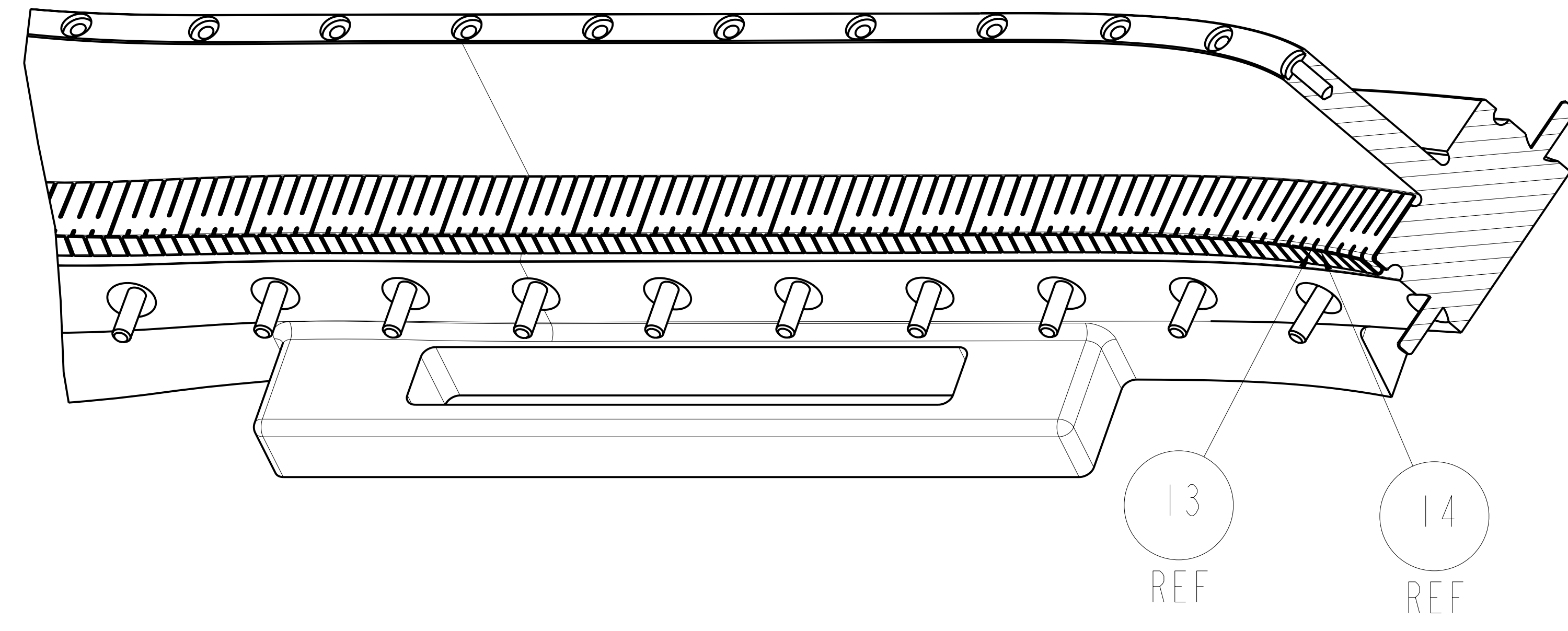

TRIMETRIC VIEW SECTION B-B  
SCALE 0.50

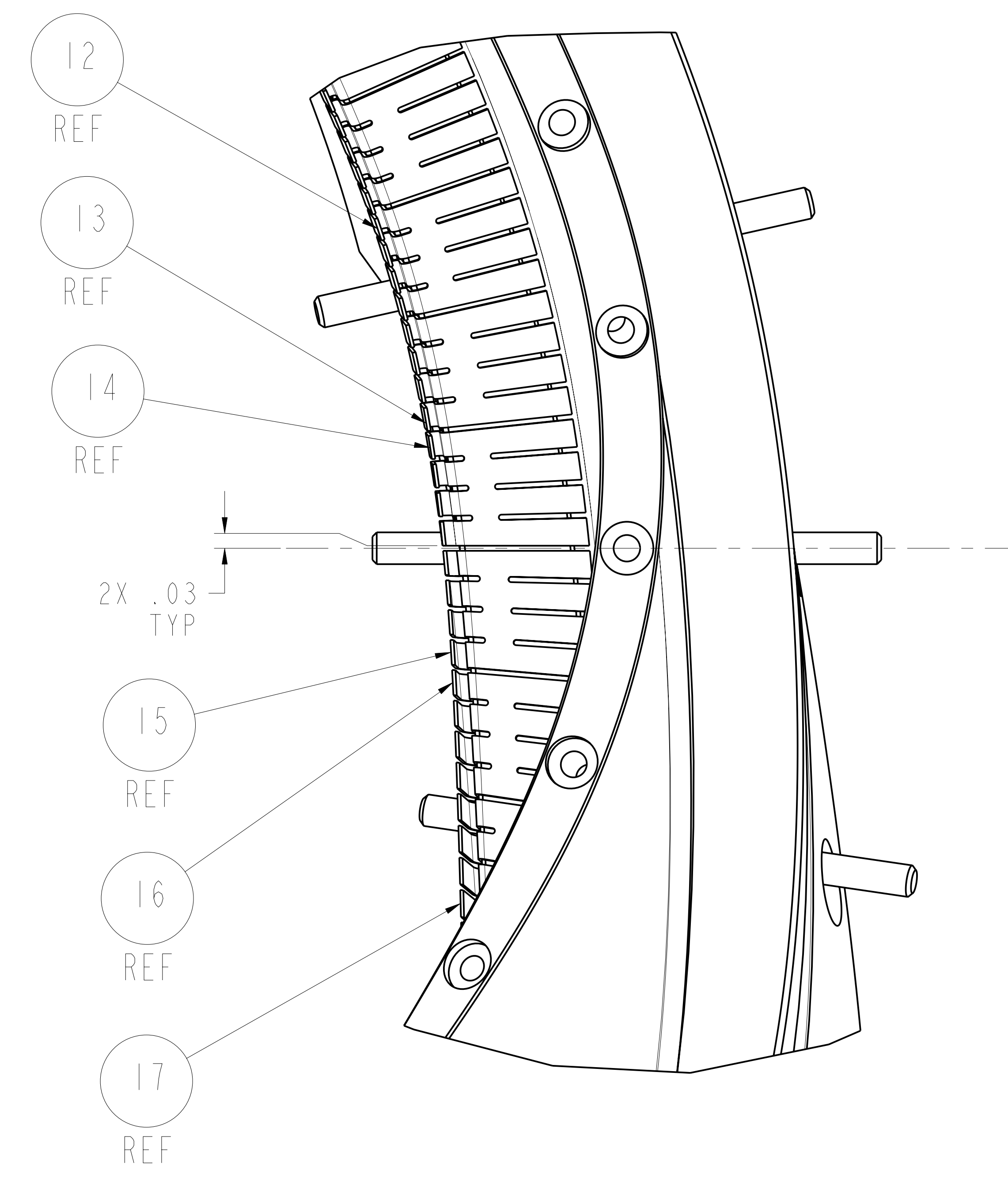

SECTION C-C

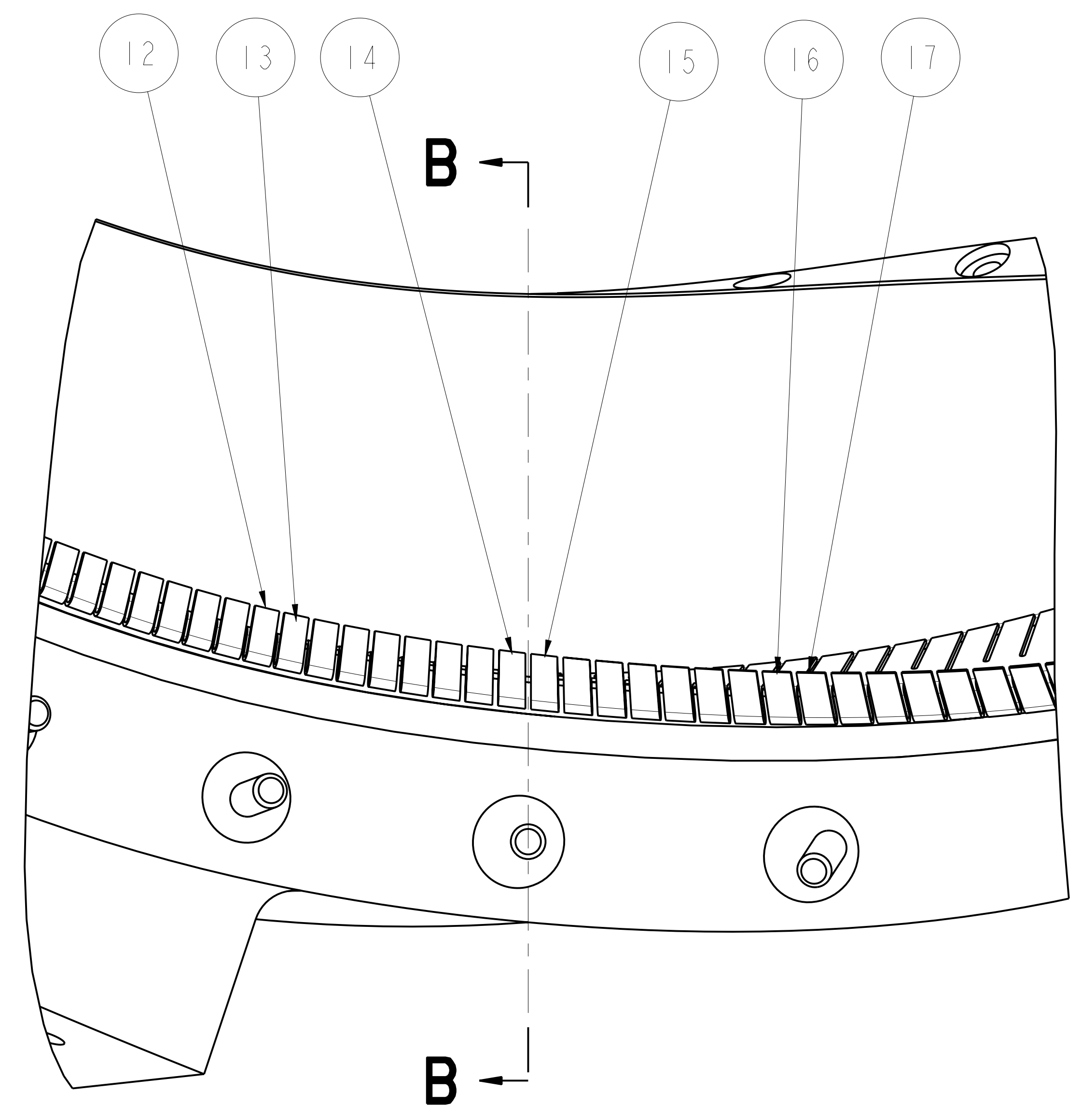

VIEW PERPENDICULAR TO WINDING  
SURFACE AT CLAMP INTERFACE  
SCALE 1.00

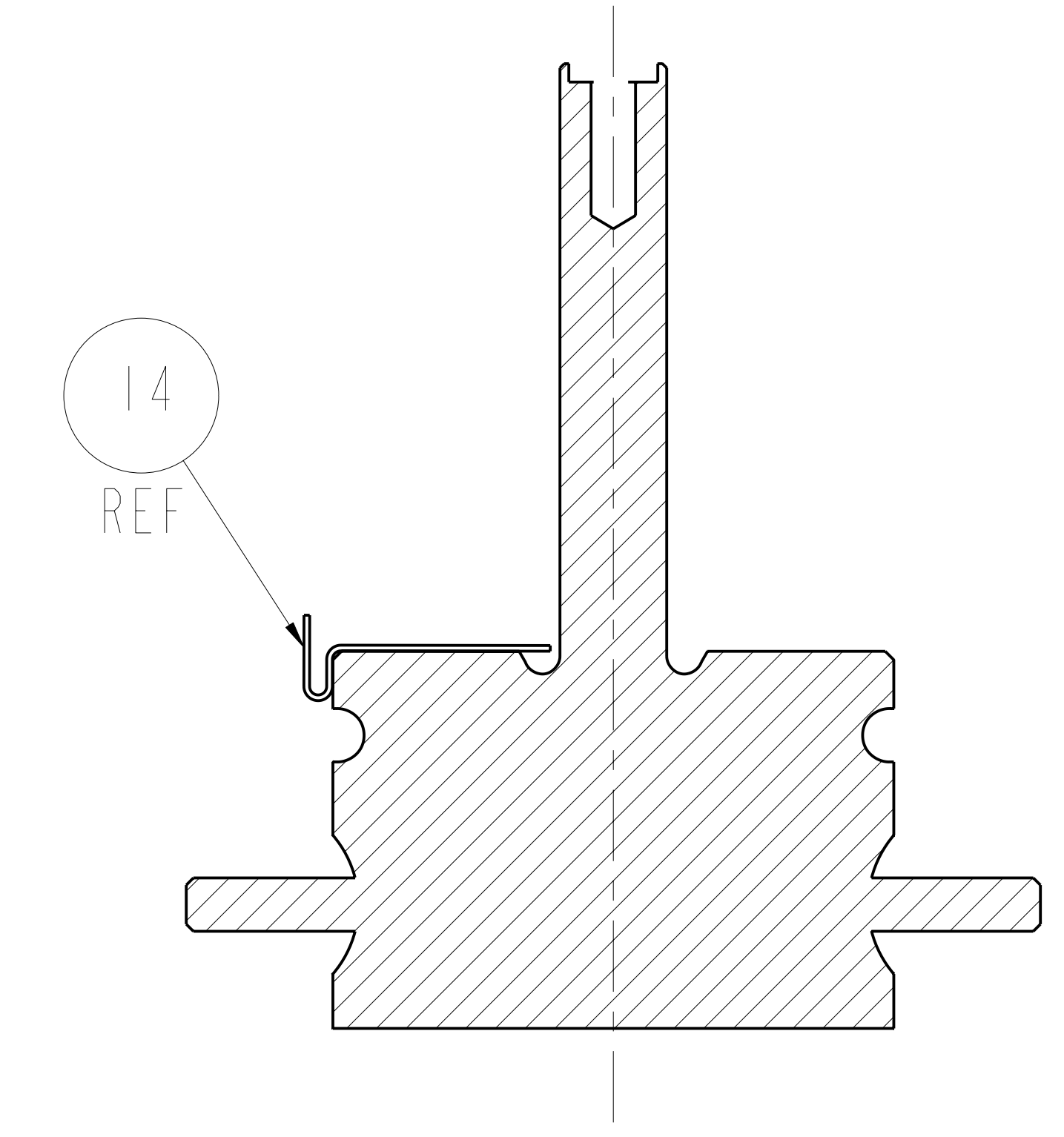

SECTION B-B

Oak Ridge National Laboratory managed for the DEPARTMENT OF ENERGY under U.S. GOVERNMENT contract DE-AC05-00OR22725 UT-BATTELLE, LLC, Oak Ridge, Tennessee PROJECT NAME:						
<b>NATIONAL COMPACT STELLARATOR EXPERIMENT</b>						
<b>TWISTED RACETRACK SIDE I FLANGE, COPPER CLADDING FABRICATED INSTALLATION</b>						
VERSION NO:	PLANT	BLDG	FL	SHT	OF	TYPE CLASS
2+		5700	3	4	4	U
RELEASE LEVEL		SE140-285			REV	
Fabrication					0	

QTY	PART NO	DESCRIPTION	MATERIAL	WEIGHT	FIND NO
1	SE140-290-90	SIDE 2 WEB, FORMED CLAD # 90	COPPER	0.0700	90
1	SE140-290-89	SIDE 2 WEB, FORMED CLAD # 89	COPPER	0.0703	89
1	SE140-290-88	SIDE 2 WEB, FORMED CLAD # 88	COPPER	0.0705	88
1	SE140-290-87	SIDE 2 WEB, FORMED CLAD # 87	COPPER	0.0708	87
1	SE140-290-86	SIDE 2 WEB, FORMED CLAD # 86	COPPER	0.0712	86
1	SE140-290-85	SIDE 2 WEB, FORMED CLAD # 85	COPPER	0.0719	85
1	SE140-290-84	SIDE 2 WEB, FORMED CLAD # 84	COPPER	0.0732	84
1	SE140-290-83	SIDE 2 WEB, FORMED CLAD # 83	COPPER	0.0750	83
1	SE140-290-82	SIDE 2 WEB, FORMED CLAD # 82	COPPER	0.0766	82
1	SE140-290-81	SIDE 2 WEB, FORMED CLAD # 81	COPPER	0.0775	81
1	SE140-290-80	SIDE 2 WEB, FORMED CLAD # 80	COPPER	0.0777	80
1	SE140-290-79	SIDE 2 WEB, FORMED CLAD # 79	COPPER	0.0775	79
1	SE140-290-78	SIDE 2 WEB, FORMED CLAD # 78	COPPER	0.0778	78
1	SE140-290-77	SIDE 2 WEB, FORMED CLAD # 77	COPPER	0.0786	77
1	SE140-290-76	SIDE 2 WEB, FORMED CLAD # 76	COPPER	0.0799	76
1	SE140-290-75	SIDE 2 WEB, FORMED CLAD # 75	COPPER	0.0806	75
1	SE140-290-74	SIDE 2 WEB, FORMED CLAD # 74	COPPER	0.0798	74
1	SE140-290-73	SIDE 2 WEB, FORMED CLAD # 73	COPPER	0.0777	73
1	SE140-290-72	SIDE 2 WEB, FORMED CLAD # 72	COPPER	0.0754	72
1	SE140-290-71	SIDE 2 WEB, FORMED CLAD # 71	COPPER	0.0738	71
1	SE140-290-70	SIDE 2 WEB, FORMED CLAD # 70	COPPER	0.0729	70
1	SE140-290-69	SIDE 2 WEB, FORMED CLAD # 69	COPPER	0.0728	69
1	SE140-290-68	SIDE 2 WEB, FORMED CLAD # 68	COPPER	0.0730	68
1	SE140-290-67	SIDE 2 WEB, FORMED CLAD # 67	COPPER	0.0735	67
1	SE140-290-66	SIDE 2 WEB, FORMED CLAD # 66	COPPER	0.0739	66
1	SE140-290-65	SIDE 2 WEB, FORMED CLAD # 65	COPPER	0.0744	65
1	SE140-290-64	SIDE 2 WEB, FORMED CLAD # 64	COPPER	0.0748	64
1	SE140-290-63	SIDE 2 WEB, FORMED CLAD # 63	COPPER	0.0753	63
1	SE140-290-62	SIDE 2 WEB, FORMED CLAD # 62	COPPER	0.0754	62
1	SE140-290-61	SIDE 2 WEB, FORMED CLAD # 61	COPPER	0.0754	61
1	SE140-290-60	SIDE 2 WEB, FORMED CLAD # 60	COPPER	0.0749	60
1	SE140-290-59	SIDE 2 WEB, FORMED CLAD # 59	COPPER	0.0743	59
1	SE140-290-58	SIDE 2 WEB, FORMED CLAD # 58	COPPER	0.0735	58
1	SE140-290-57	SIDE 2 WEB, FORMED CLAD # 57	COPPER	0.0727	57
1	SE140-290-56	SIDE 2 WEB, FORMED CLAD # 56	COPPER	0.0723	56
1	SE140-290-55	SIDE 2 WEB, FORMED CLAD # 55	COPPER	0.0722	55
1	SE140-290-54	SIDE 2 WEB, FORMED CLAD # 54	COPPER	0.0726	54
1	SE140-290-53	SIDE 2 WEB, FORMED CLAD # 53	COPPER	0.0736	53
1	SE140-290-52	SIDE 2 WEB, FORMED CLAD # 52	COPPER	0.0749	52
1	SE140-290-51	SIDE 2 WEB, FORMED CLAD # 51	COPPER	0.0762	51
1	SE140-290-50	SIDE 2 WEB, FORMED CLAD # 50	COPPER	0.0771	50
1	SE140-290-49	SIDE 2 WEB, FORMED CLAD # 49	COPPER	0.0777	49
1	SE140-290-48	SIDE 2 WEB, FORMED CLAD # 48	COPPER	0.0779	48
1	SE140-290-47	SIDE 2 WEB, FORMED CLAD # 47	COPPER	0.0779	47
1	SE140-290-46	SIDE 2 WEB, FORMED CLAD # 46	COPPER	0.0784	46
1	SE140-290-45	SIDE 2 WEB, FORMED CLAD # 45	COPPER	0.0784	45
1	SE140-290-44	SIDE 2 WEB, FORMED CLAD # 44	COPPER	0.0788	44
1	SE140-290-43	SIDE 2 WEB, FORMED CLAD # 43	COPPER	0.0782	43
1	SE140-290-42	SIDE 2 WEB, FORMED CLAD # 42	COPPER	0.0777	42
1	SE140-290-41	SIDE 2 WEB, FORMED CLAD # 41	COPPER	0.0756	41
1	SE140-290-40	SIDE 2 WEB, FORMED CLAD # 40	COPPER	0.0740	40
1	SE140-290-39	SIDE 2 WEB, FORMED CLAD # 39	COPPER	0.0716	39
1	SE140-290-38	SIDE 2 WEB, FORMED CLAD # 38	COPPER	0.0704	38
1	SE140-290-37	SIDE 2 WEB, FORMED CLAD # 37	COPPER	0.0685	37
1	SE140-290-36	SIDE 2 WEB, FORMED CLAD # 36	COPPER	0.0681	36
1	SE140-290-35	SIDE 2 WEB, FORMED CLAD # 35	COPPER	0.0671	35
1	SE140-290-34	SIDE 2 WEB, FORMED CLAD # 34	COPPER	0.0676	34
1	SE140-290-33	SIDE 2 WEB, FORMED CLAD # 33	COPPER	0.0673	33
1	SE140-290-32	SIDE 2 WEB, FORMED CLAD # 32	COPPER	0.0682	32
1	SE140-290-31	SIDE 2 WEB, FORMED CLAD # 31	COPPER	0.0684	31
1	SE140-290-30	SIDE 2 WEB, FORMED CLAD # 30	COPPER	0.0694	30
1	SE140-290-29	SIDE 2 WEB, FORMED CLAD # 29	COPPER	0.0692	29
1	SE140-290-28	SIDE 2 WEB, FORMED CLAD # 28	COPPER	0.0700	28
1	SE140-290-27	SIDE 2 WEB, FORMED CLAD # 27	COPPER	0.0700	27
1	SE140-290-26	SIDE 2 WEB, FORMED CLAD # 26	COPPER	0.0711	26
1	SE140-290-25	SIDE 2 WEB, FORMED CLAD # 25	COPPER	0.0711	25
1	SE140-290-24	SIDE 2 WEB, FORMED CLAD # 24	COPPER	0.0721	24
1	SE140-290-23	SIDE 2 WEB, FORMED CLAD # 23	COPPER	0.0719	23
1	SE140-290-22	SIDE 2 WEB, FORMED CLAD # 22	COPPER	0.0726	22
1	SE140-290-21	SIDE 2 WEB, FORMED CLAD # 21	COPPER	0.0723	21
1	SE140-290-20	SIDE 2 WEB, FORMED CLAD # 20	COPPER	0.0732	20
1	SE140-290-19	SIDE 2 WEB, FORMED CLAD # 19	COPPER	0.0729	19
1	SE140-290-18	SIDE 2 WEB, FORMED CLAD # 18	COPPER	0.0739	18
1	SE140-290-17	SIDE 2 WEB, FORMED CLAD # 17	COPPER	0.0736	17
1	SE140-290-16	SIDE 2 WEB, FORMED CLAD # 16	COPPER	0.0746	16
1	SE140-290-15	SIDE 2 WEB, FORMED CLAD # 15	COPPER	0.0743	15
1	SE140-290-14	SIDE 2 WEB, FORMED CLAD # 14	COPPER	0.0751	14
1	SE140-290-13	SIDE 2 WEB, FORMED CLAD # 13	COPPER	0.0748	13
1	SE140-290-12	SIDE 2 WEB, FORMED CLAD # 12	COPPER	0.0753	12
1	SE140-290-11	SIDE 2 WEB, FORMED CLAD # 11	COPPER	0.0748	11
1	SE140-290-10	SIDE 2 WEB, FORMED CLAD # 10	COPPER	0.0751	10
1	SE140-290-9	SIDE 2 WEB, FORMED CLAD # 9	COPPER	0.0744	9
1	SE140-290-8	SIDE 2 WEB, FORMED CLAD # 8	COPPER	0.0748	8
1	SE140-290-7	SIDE 2 WEB, FORMED CLAD # 7	COPPER	0.0743	7
1	SE140-290-6	SIDE 2 WEB, FORMED CLAD # 6	COPPER	0.0747	6
1	SE140-290-5	SIDE 2 WEB, FORMED CLAD # 5	COPPER	0.0743	5
1	SE140-290-4	SIDE 2 WEB, FORMED CLAD # 4	COPPER	0.0747	4
1	SE140-290-3	SIDE 2 WEB, FORMED CLAD # 3	COPPER	0.0743	3
1	SE140-290-2	SIDE 2 WEB, FORMED CLAD # 2	COPPER	0.0748	2
1	SE140-290-1	SIDE 2 WEB, FORMED CLAD # 1	COPPER	0.0743	1
1	SE140-286-1	SIDE 2 WEB COPPER CLADDING FAB INSTALL	-	6.8201	-

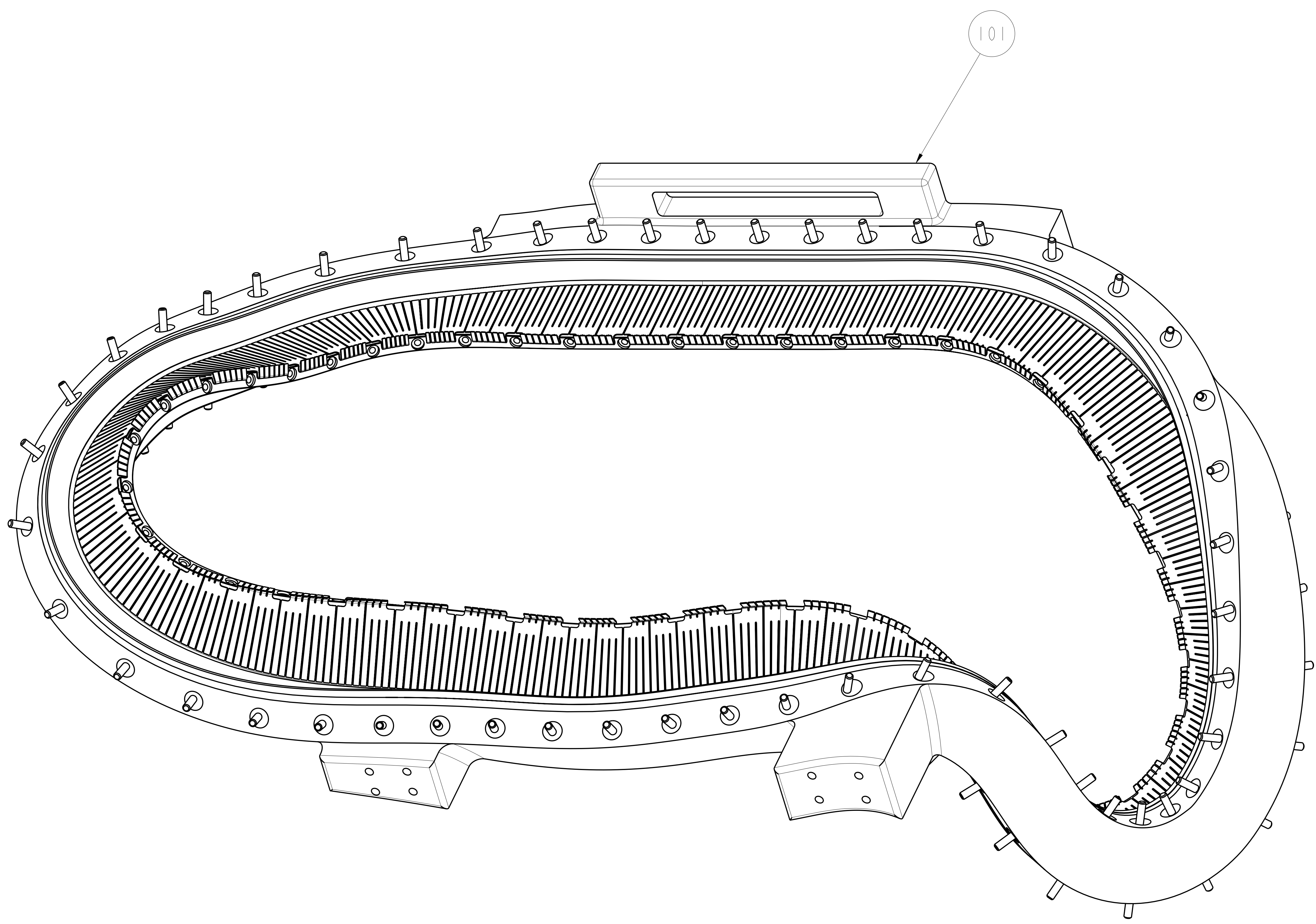

-1 SIDE 2 WEB COPPER CLADDING FABRICATED INSTALLATION REVERSE TRIMETRIC VIEW SCALE 0.375

QTY	PART NO	DESCRIPTION	MATERIAL	WEIGHT	FIND NO
1	SE1406-011	TWISTED RACETRACK WINDING FORM WLDMT	STEEL	730.0000	101
1	SE140-290-100	SIDE 2 WEB, FORMED CLAD # 100	COPPER	0.0747	100
1	SE140-290-99	SIDE 2 WEB, FORMED CLAD # 99	COPPER	0.0747	99
1	SE140-290-98	SIDE 2 WEB, FORMED CLAD # 98	COPPER	0.0749	98
1	SE140-290-97	SIDE 2 WEB, FORMED CLAD # 97	COPPER	0.0750	97
1	SE140-290-96	SIDE 2 WEB, FORMED CLAD # 96	COPPER	0.0748	96
1	SE140-290-95	SIDE 2 WEB, FORMED CLAD # 95	COPPER	0.0742	95
1	SE140-290-94	SIDE 2 WEB, FORMED CLAD # 94	COPPER	0.0731	94
1	SE140-290-93	SIDE 2 WEB, FORMED CLAD # 93	COPPER	0.0716	93
1	SE140-290-92	SIDE 2 WEB, FORMED CLAD # 92	COPPER	0.0704	92
1	SE140-290-91	SIDE 2 WEB, FORMED CLAD # 91	COPPER	0.0699	91

next assy	CAGE CODE	PART OR IDENTIFYING NO	NOMENCLATURE OR DESCRIPTION	MATERIAL	WEIGHT	FIND NO
-----------	-----------	------------------------	-----------------------------	----------	--------	---------

REV	DESCRIPTION	BY	DATE	CHK	DEPT	DATE	PE	REQ	DATE	ORNL	DOE	DATE
-----	-------------	----	------	-----	------	------	----	-----	------	------	-----	------

DES	BRAD NELSON	07/10/04
DRW	TOM HARGROVE	07/10/04
CHK	:	:
SECT	:	:
DEPT	:	:
FE	:	:
CR	:	:
PJ	:	:
REQ	:	:
FINISH	125 UNLESS OTHERWISE SPECIFIED	:

VERSION NO.	PLANT	BLDG	FL	SHT	TYPE	CLASS
2+		5700	3	1	4	U

RELEASE LEVEL: Fabrication

SEI40-286

SEI40-286

NO REPRESENTATION OR WARRANTY EXPRESSED OR IMPLIED IS MADE AS TO THE ACCURACY, COMPLETENESS OR USEFULNESS OF THE INFORMATION OR STATEMENTS CONTAINED IN THESE DRAWINGS, OR THAT THE USE OR DISCLOSURE OF ANY INFORMATION, APPARATUS, METHOD OR PROCESS DISCLOSED IN THESE DRAWINGS MAY NOT INFRINGE PRIVATE RIGHTS OF OTHERS. NO LIABILITY IS ASSUMED WITH RESPECT TO THE USE OF, OR FOR DAMAGES RESULTING FROM THE USE OF, ANY INFORMATION, APPARATUS, METHOD OR PROCESS DISCLOSED IN THESE DRAWINGS. DRAWINGS MADE AVAILABLE FOR INFORMATION TO BIDDER ARE NOT TO BE USED FOR OTHER PURPOSES, AND ARE TO BE RETURNED UPON REQUEST OF THE FORWARDING CONTRACTOR.

**P** THIS DRAWING PRODUCED ON PRO-ENGINEER

Oak Ridge National Laboratory managed for the DEPARTMENT OF ENERGY under contract DE-AC05-00OR22725 UT-BATTELLE, LLC, Oak Ridge, Tennessee

**NATIONAL COMPACT STELLARATOR EXPERIMENT**

**TWISTED RACETRACK SIDE 2 WEB COPPER CLADDING FABRICATED INSTALLATION**

8

7

6

5

4

3

2

1

NEXT ASS'Y: 1 FINAL ASS'Y:

H

H

G

G

F

F

E

E

D

D

C

C

B

B

A

A

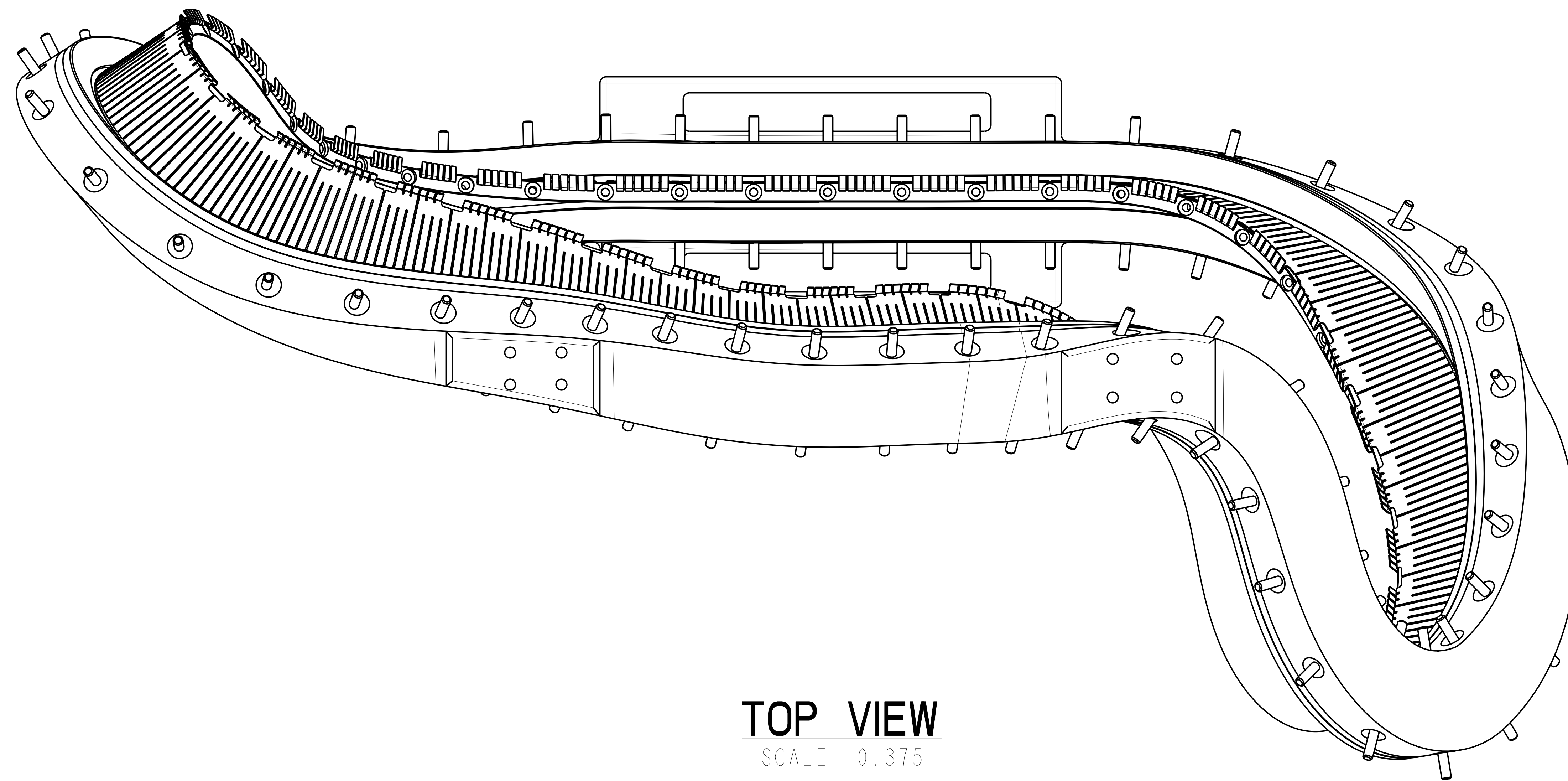
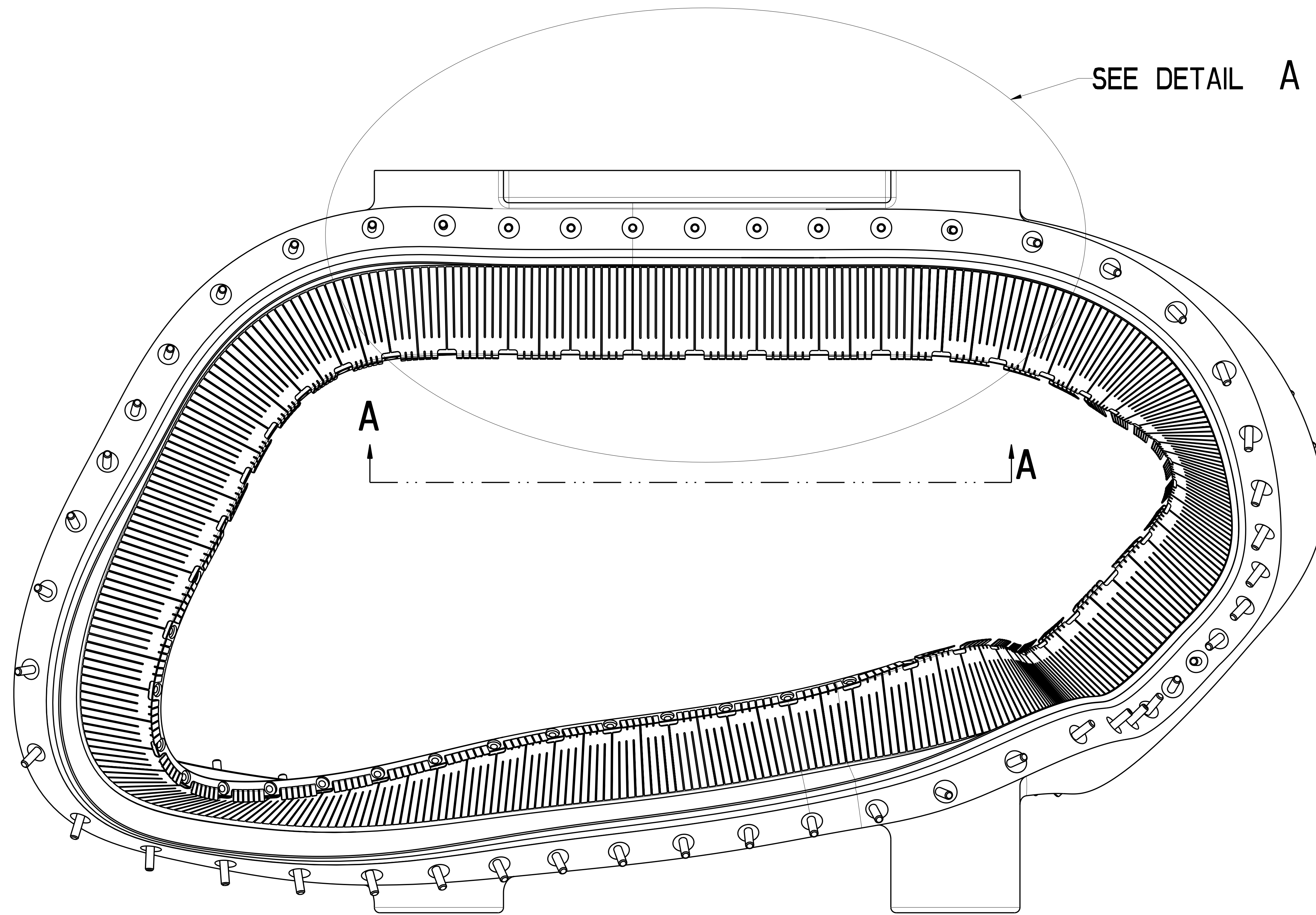

TOP VIEW  
SCALE 0:375

Oak Ridge National Laboratory managed for the DEPARTMENT OF ENERGY under U.S. GOVERNMENT contract DE-AC05-00OR22725 UT-BATTELLE, LLC, Oak Ridge, Tennessee PROJECT NAME:						
<b>UT-BATTELLE</b> NATIONAL COMPACT STELLARATOR EXPERIMENT						
TWISTED RACETRACK SIDE 2 WEB COPPER CLADDING FABRICATED INSTALLATION						
VERSION NO: 2+	PLANT	BLDG 5700	FL 3	SHT OF 2 4	TYPE	CLASS U
RELEASE LEVEL Fabrication		SE140-286			REV 0	

8

7

6

5

4

3

2

1

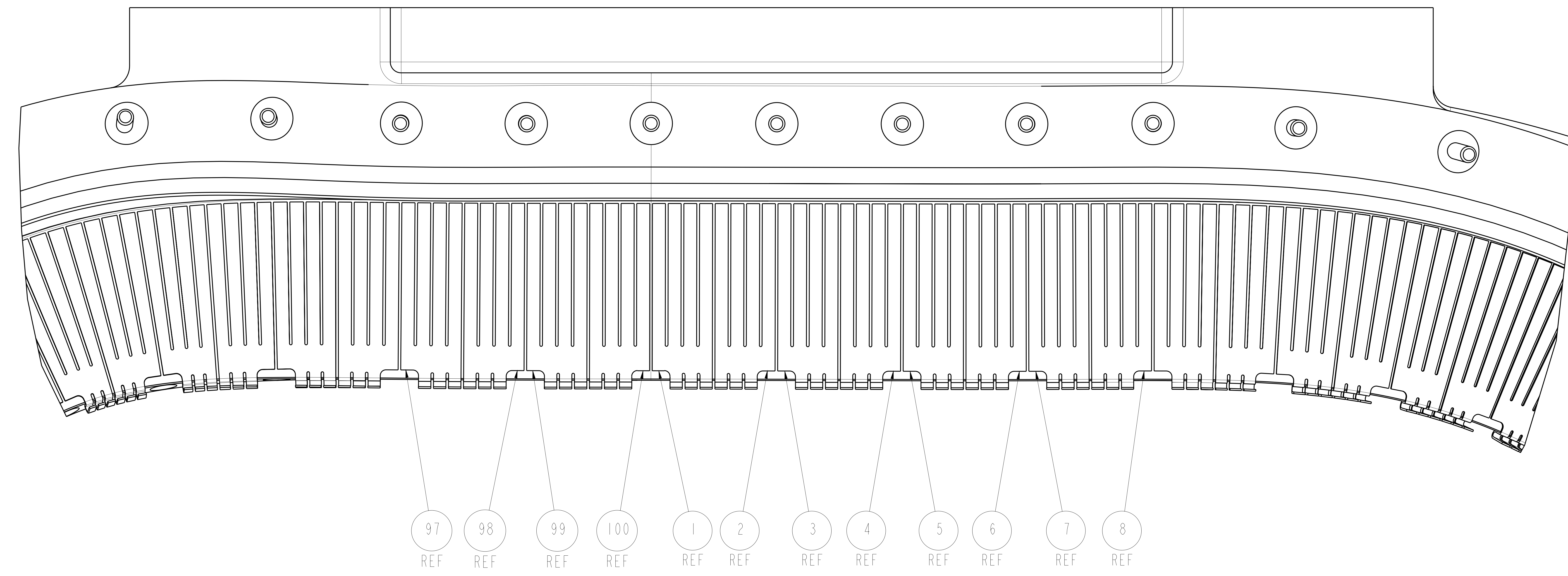

**DETAIL A**  
SCALE 1.00

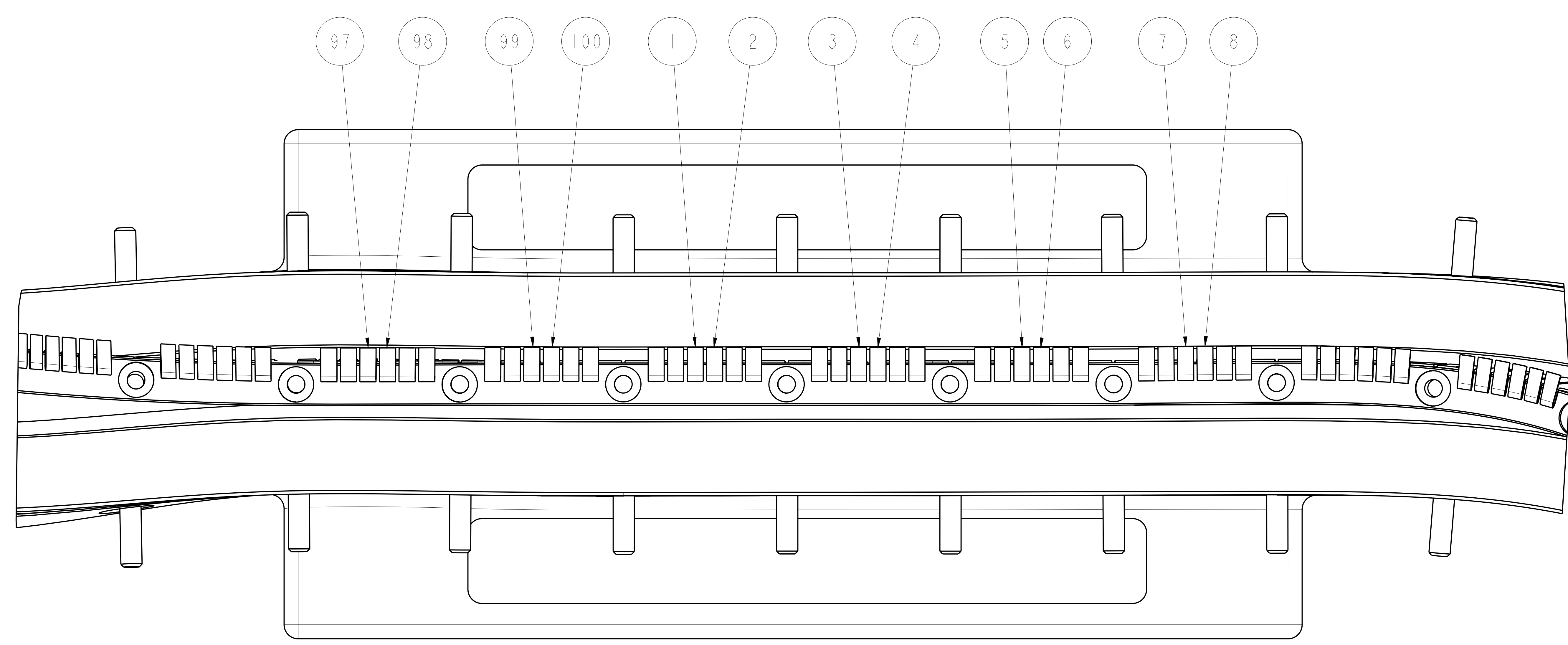

**SECTION A-A**

Oak Ridge National Laboratory managed for the DEPARTMENT OF ENERGY under U.S. GOVERNMENT CONTRACT DE-AC05-00OR22725 UT-BATTELLE, LLC, Oak Ridge, Tennessee PROJECT NAME						
<b>UT-BATTELLE</b>						
<b>NATIONAL COMPACT STELLARATOR EXPERIMENT</b>						
<b>TWISTED RACETRACK          SIDE 2 WEB COPPER CLADDING          FABRICATED INSTALLATION</b>						
VERSION NO:	PLANT	BLDG	FL	SHT	OF	TYPE CLASS
2+		5700	3	3	4	U
RELEASE LEVEL		SE140-286			REV	
Fabrication					0	

082-140-135

A

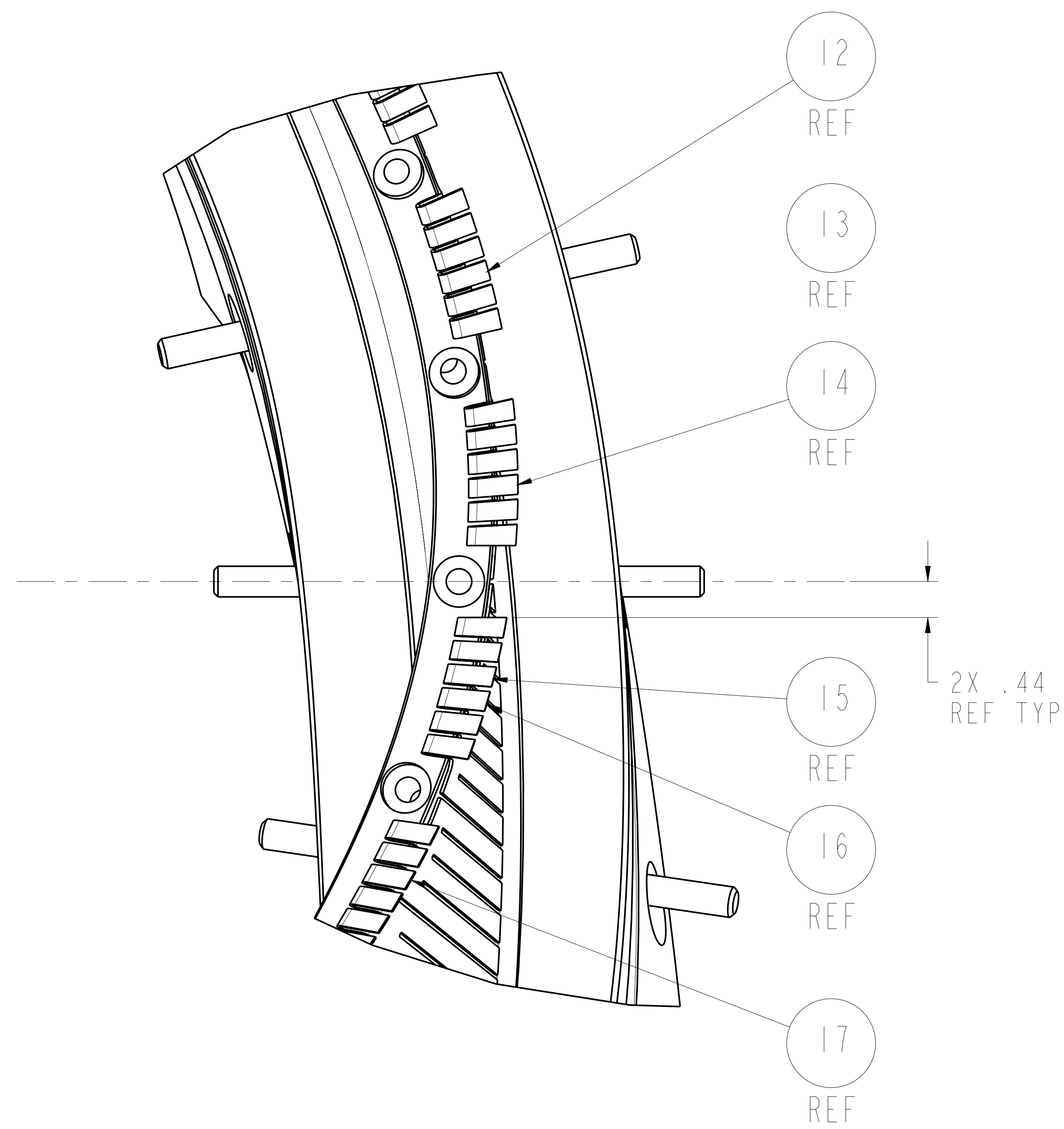

SECTION C-C

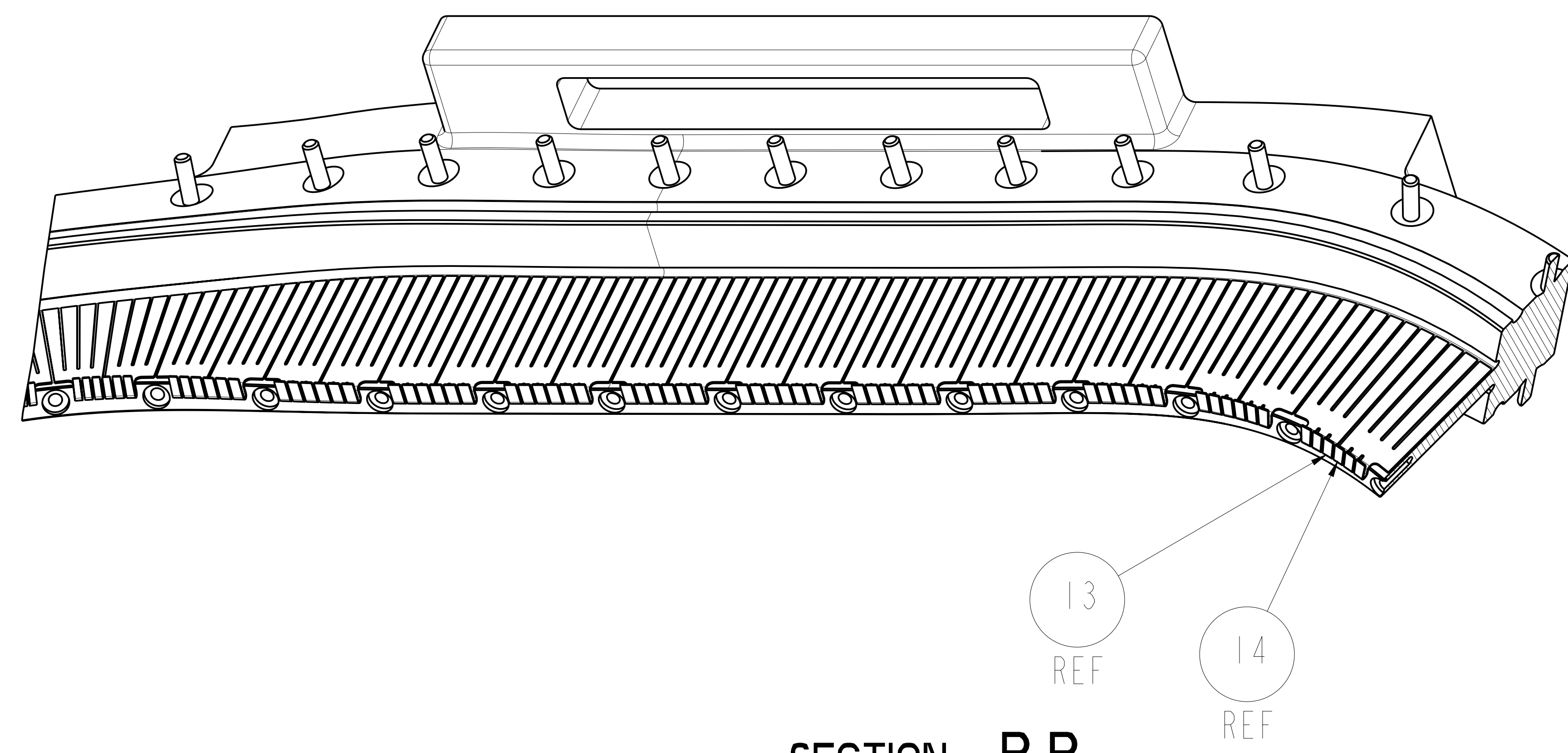

REVERSE TRIMETRIC VIEW SECTION B-B  
 SCALE 0.50

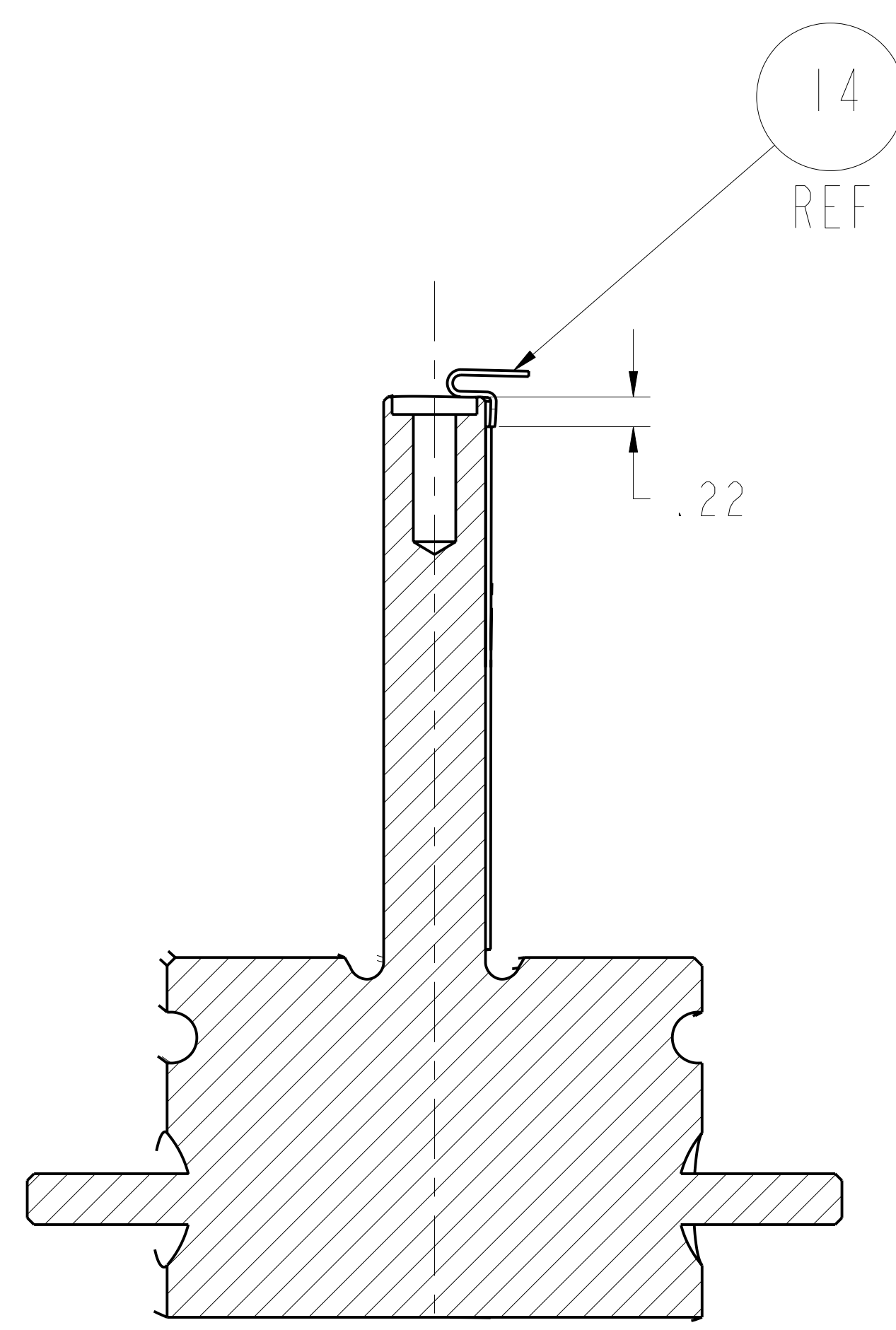

SECTION B-B

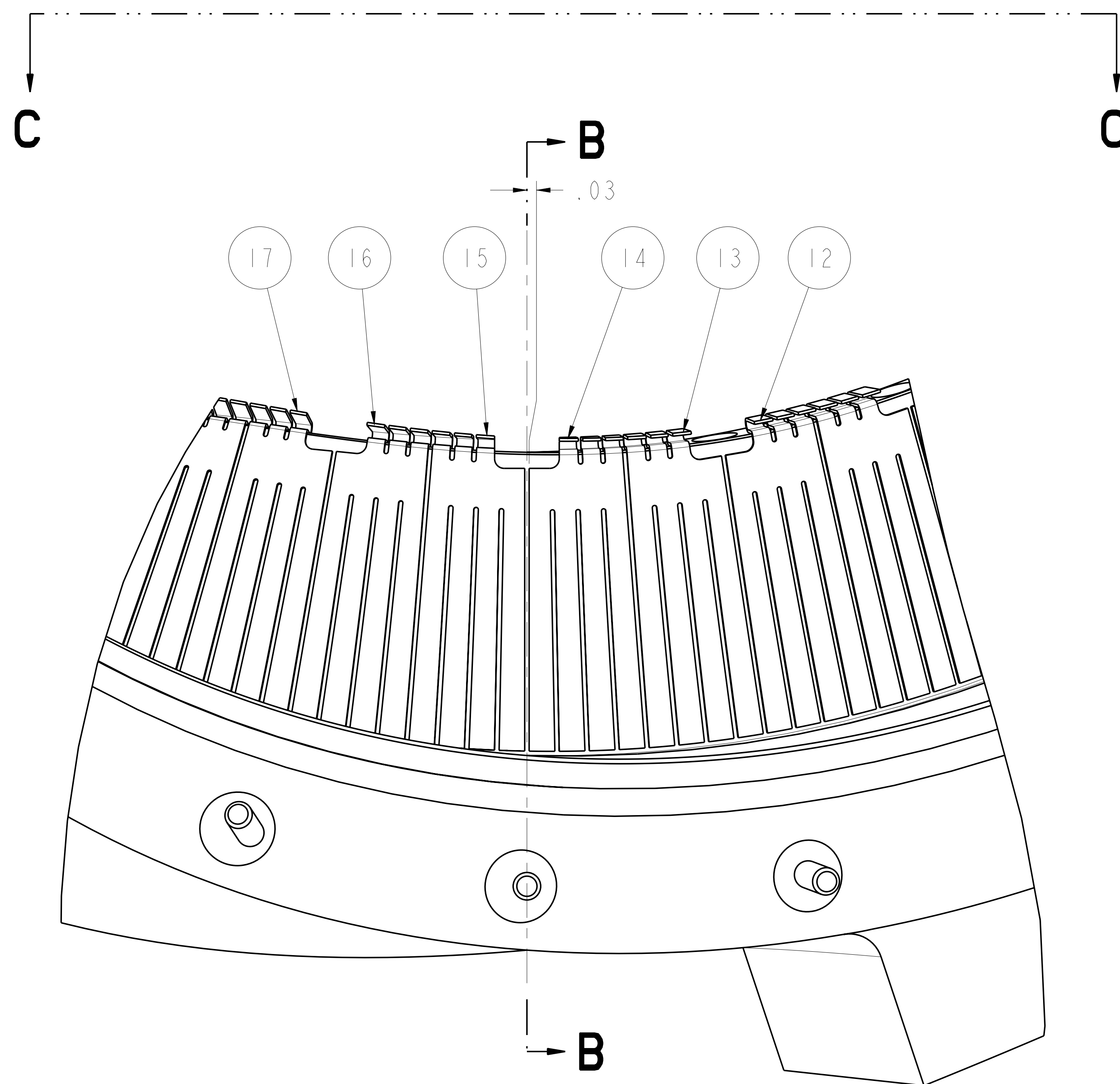

VIEW PERPENDICULAR TO WINDING  
 SURFACE AT CLAMP INTERFACE  
 SCALE 1.000

Oak Ridge National Laboratory managed for the DEPARTMENT OF ENERGY under U.S. GOVERNMENT contract DE-AC05-00OR22725 UT-BATTELLE, LLC, Oak Ridge, Tennessee PROJECT NAME:						
<b>NATIONAL COMPACT STELLARATOR EXPERIMENT</b>						
TWISTED RACETRACK SIDE 2 WEB COPPER CLADDING FABRICATED INSTALLATION						
VERSION NO: 2+	PLANT	BLDG	FL	SHT	OF	TYPE CLASS
RELEASE LEVEL Fabrication		5700	3	4	4	U
SE140-286						REV 0

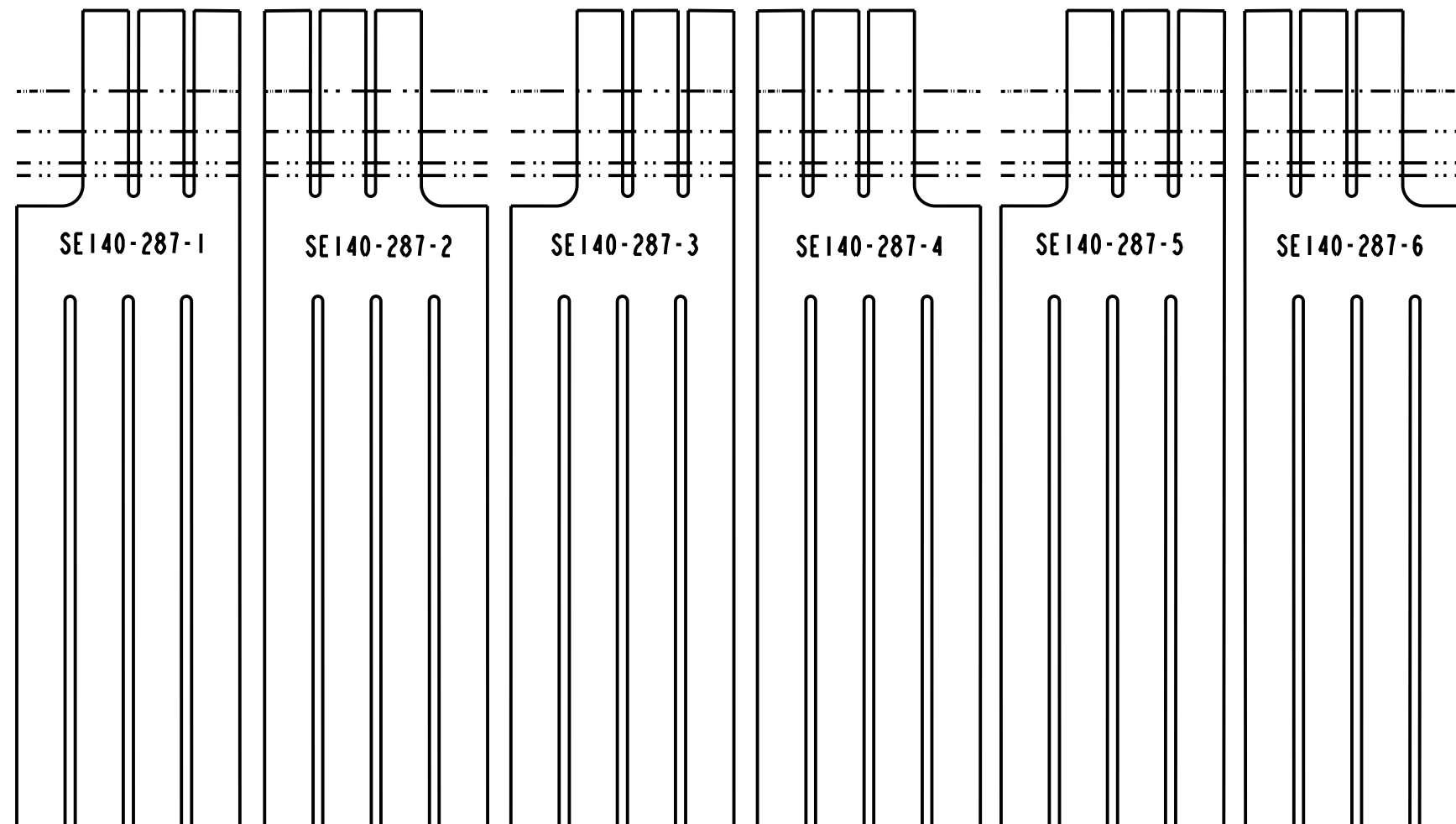

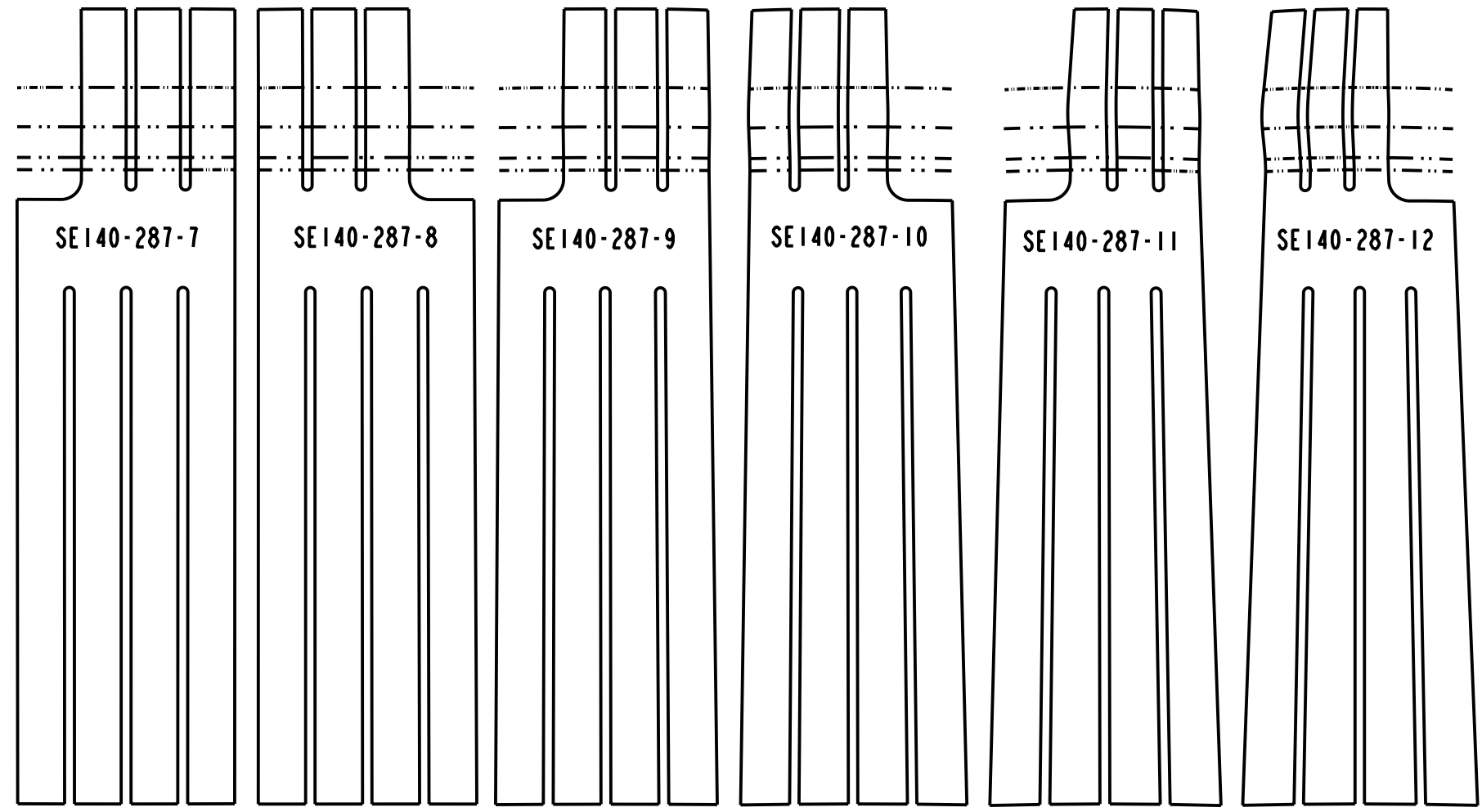

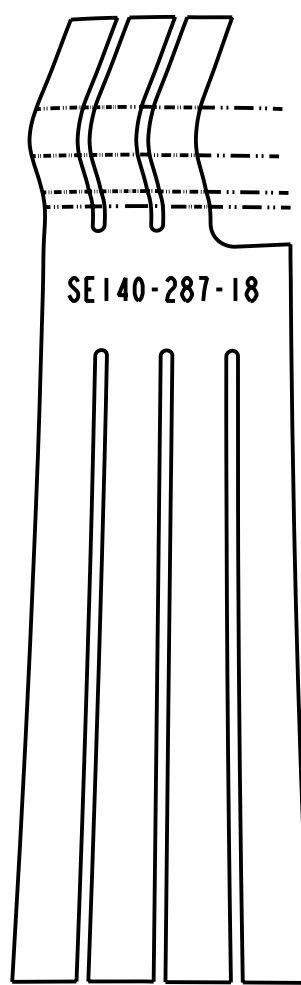
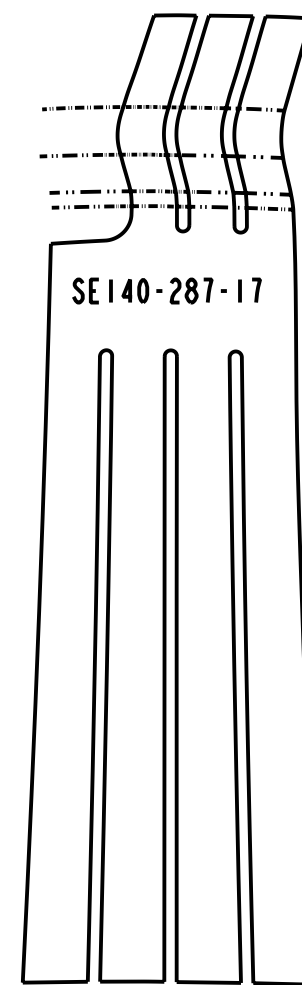
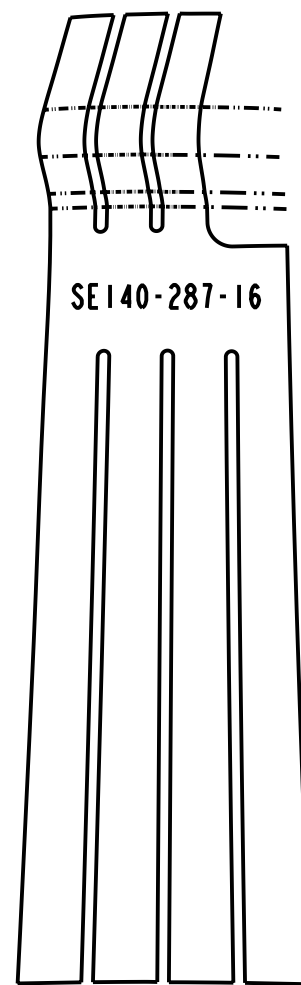
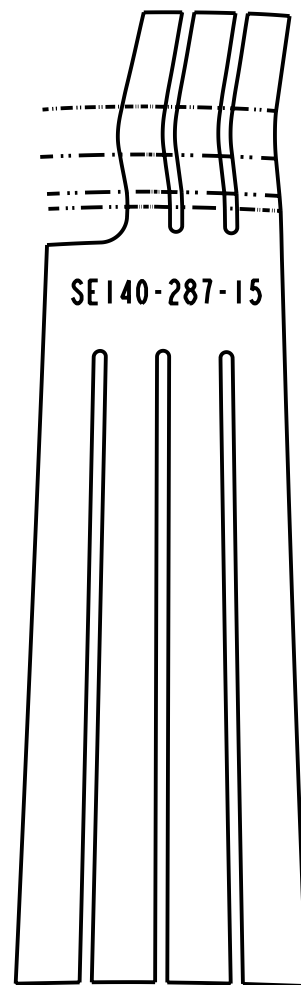
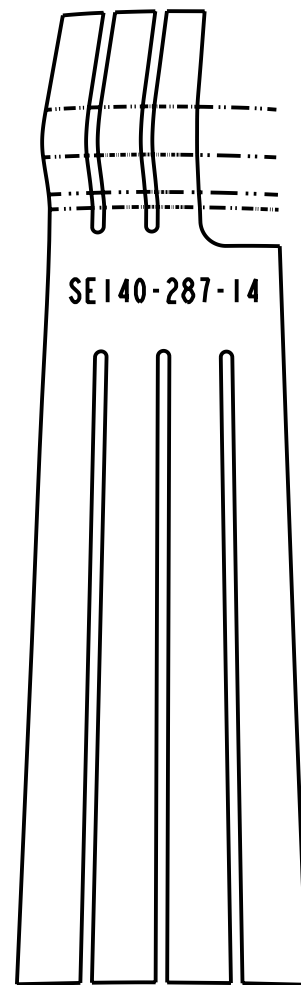
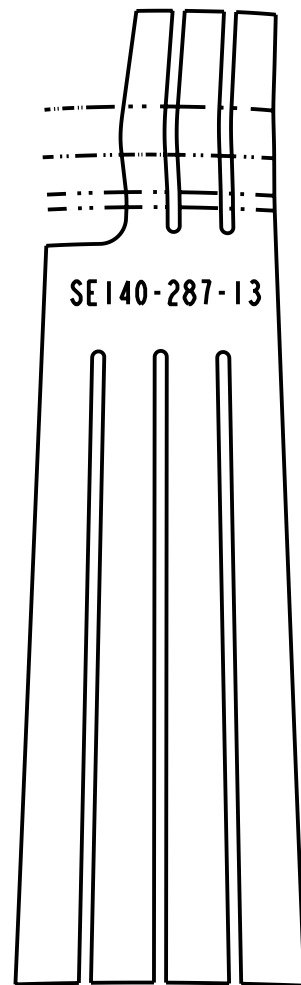



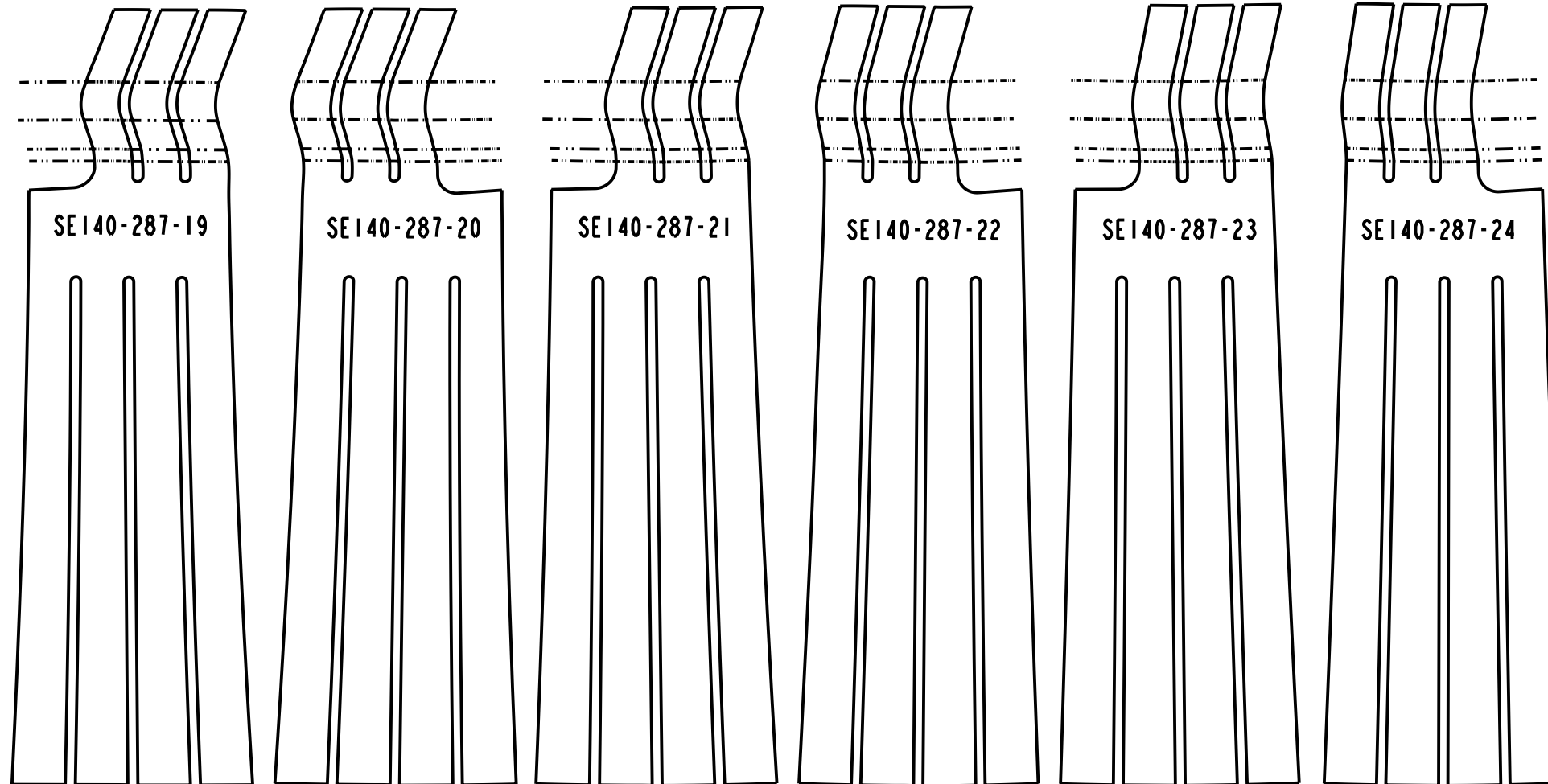

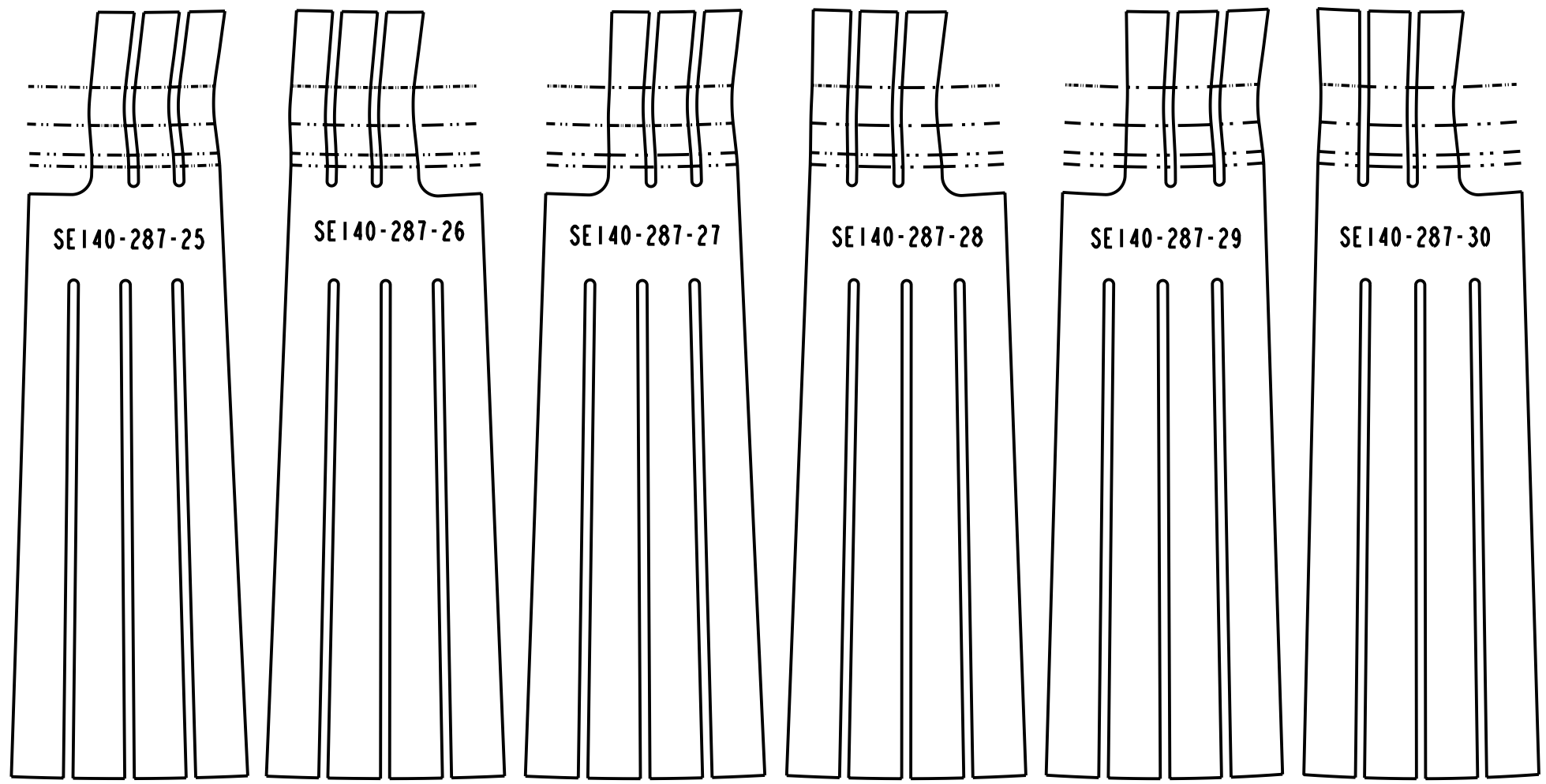

SE140-287-25

SE140-287-26

SE140-287-27

SE140-287-28

SE140-287-29

SE140-287-30

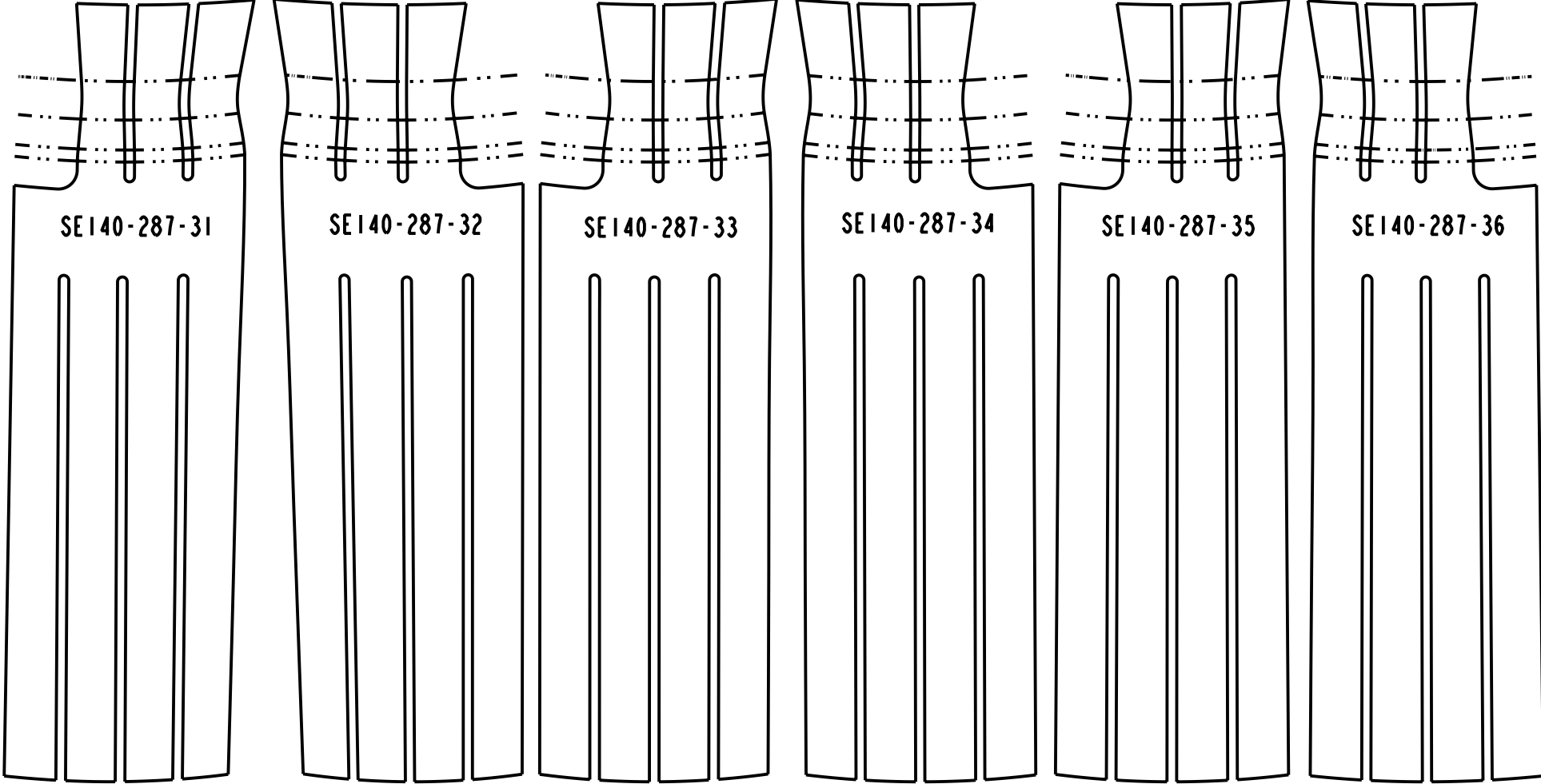

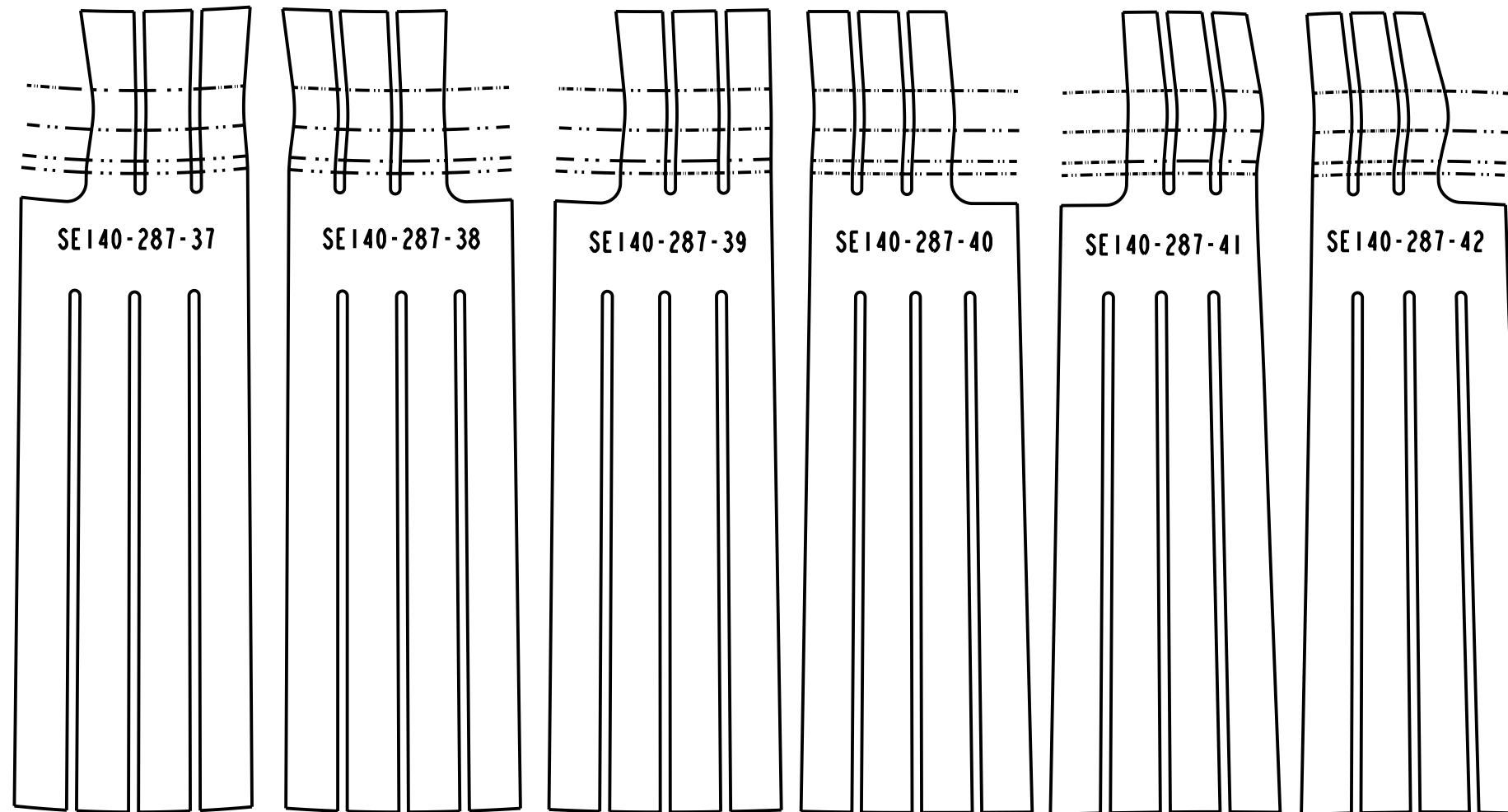

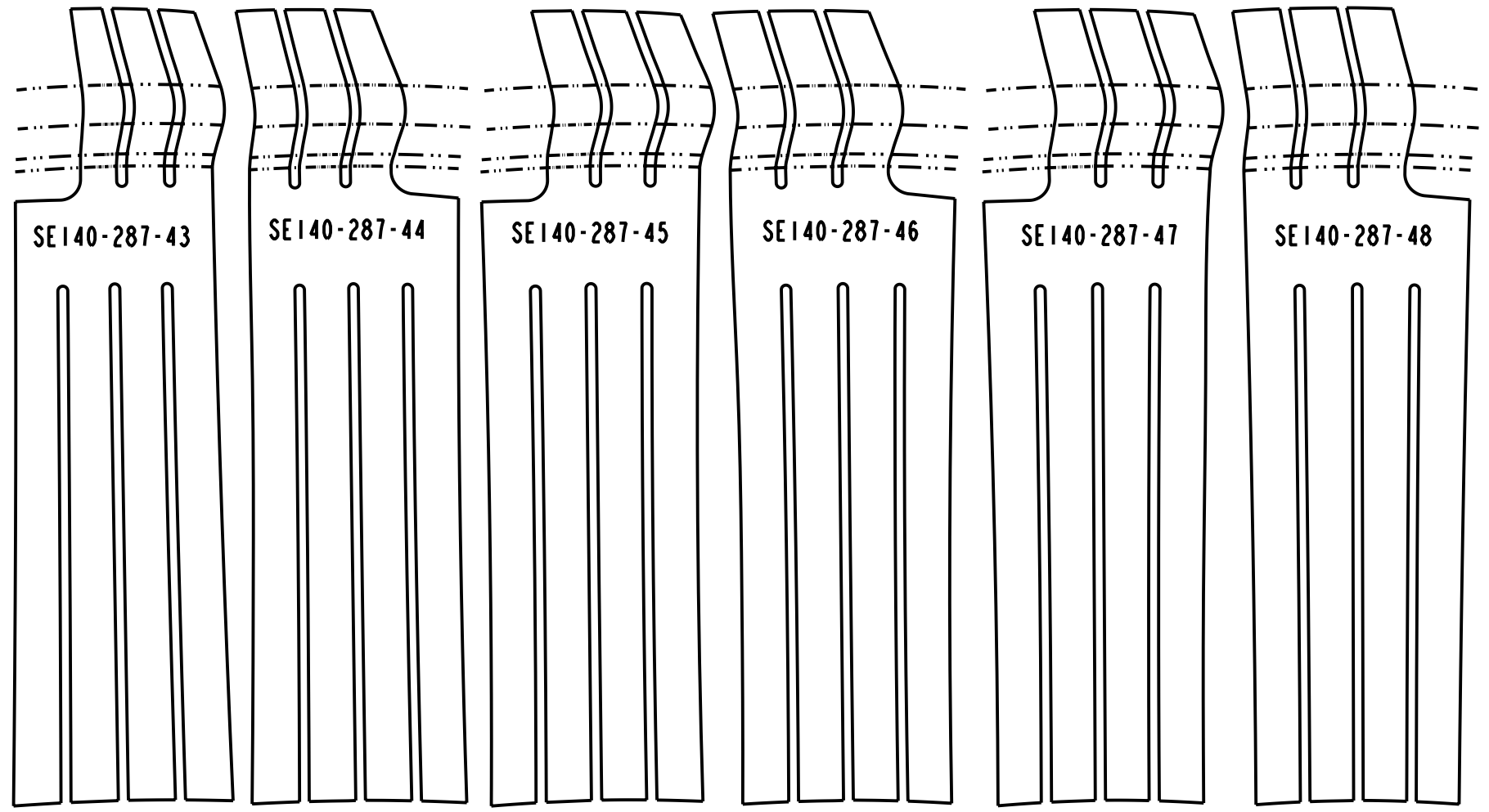

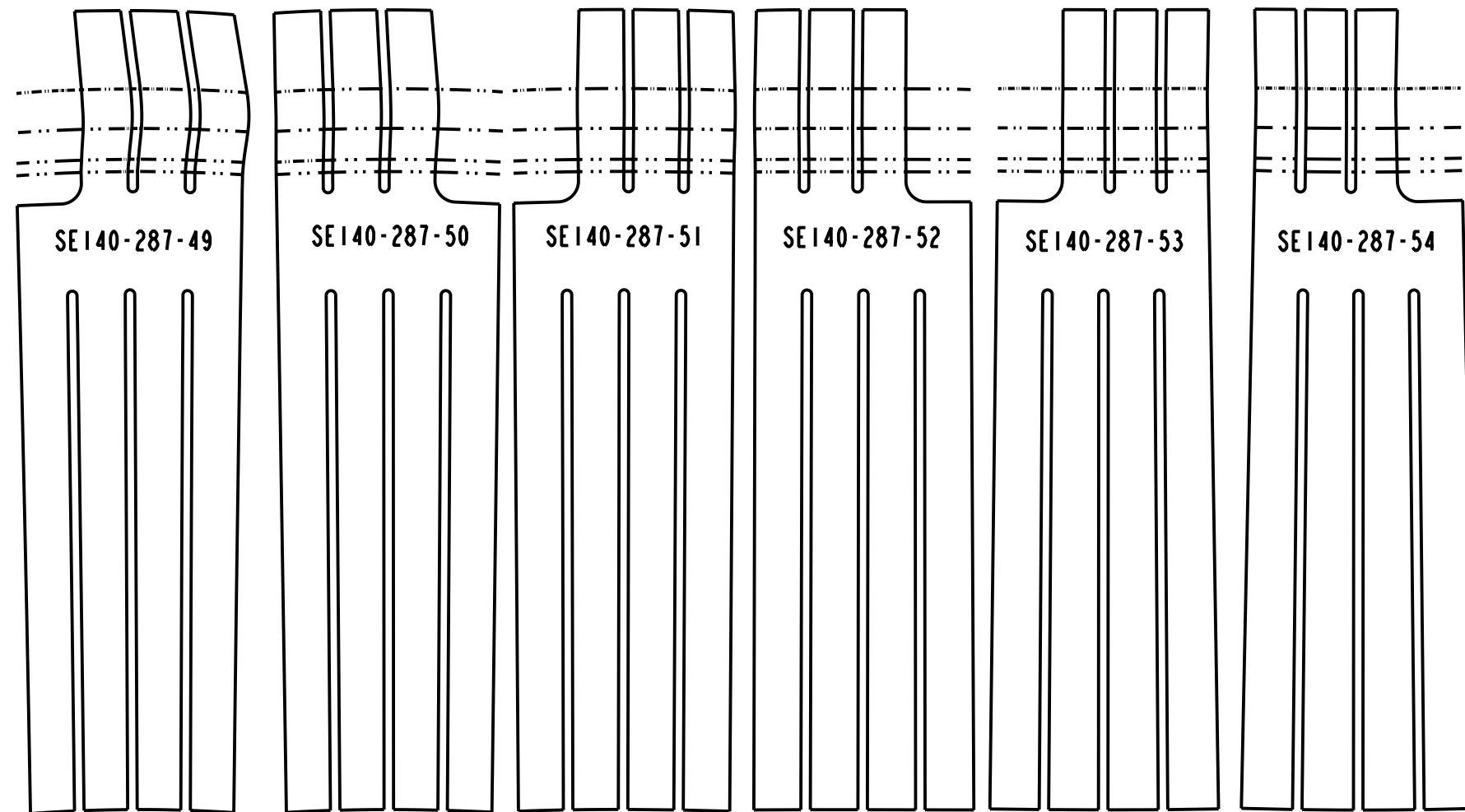

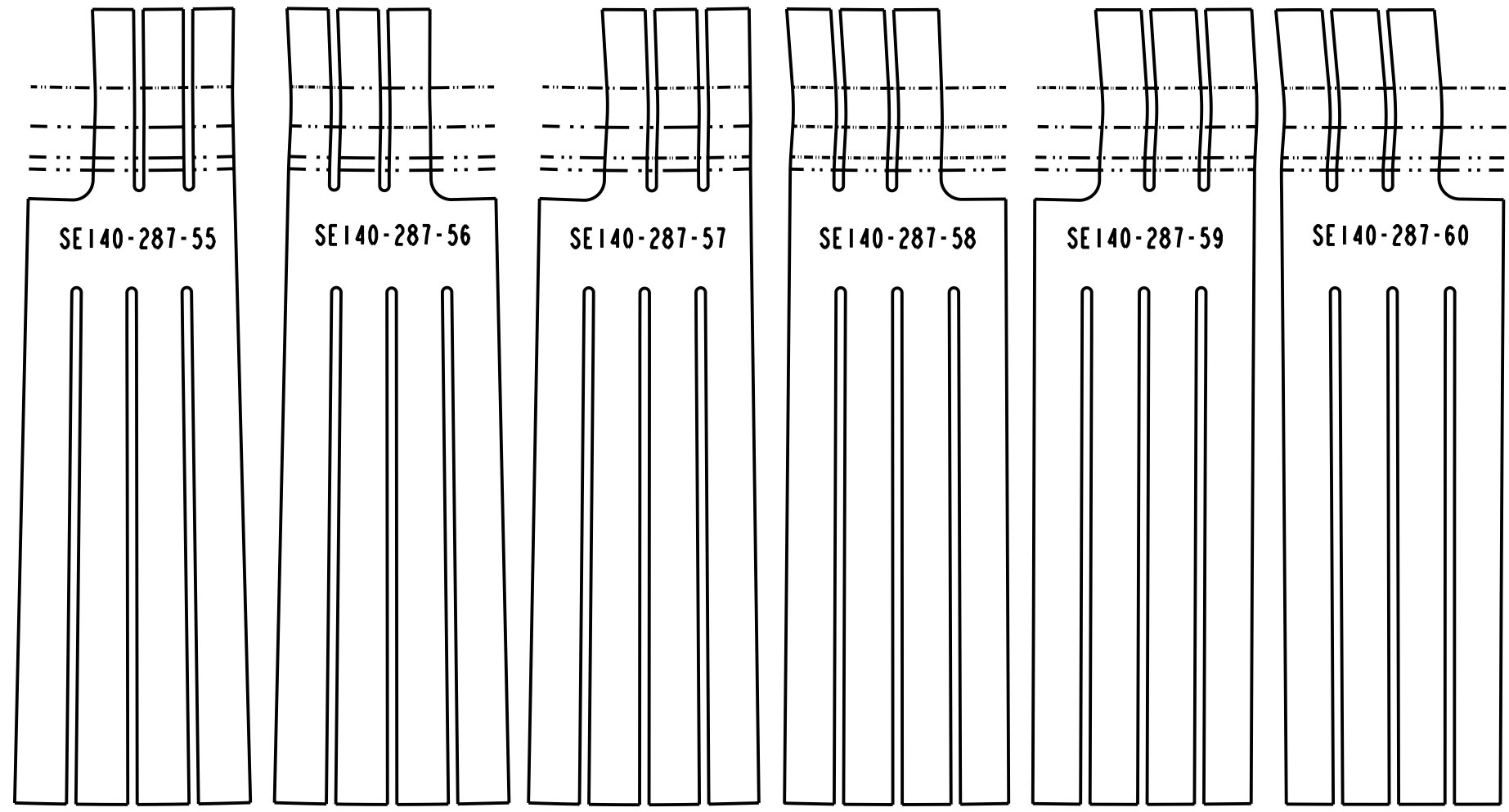

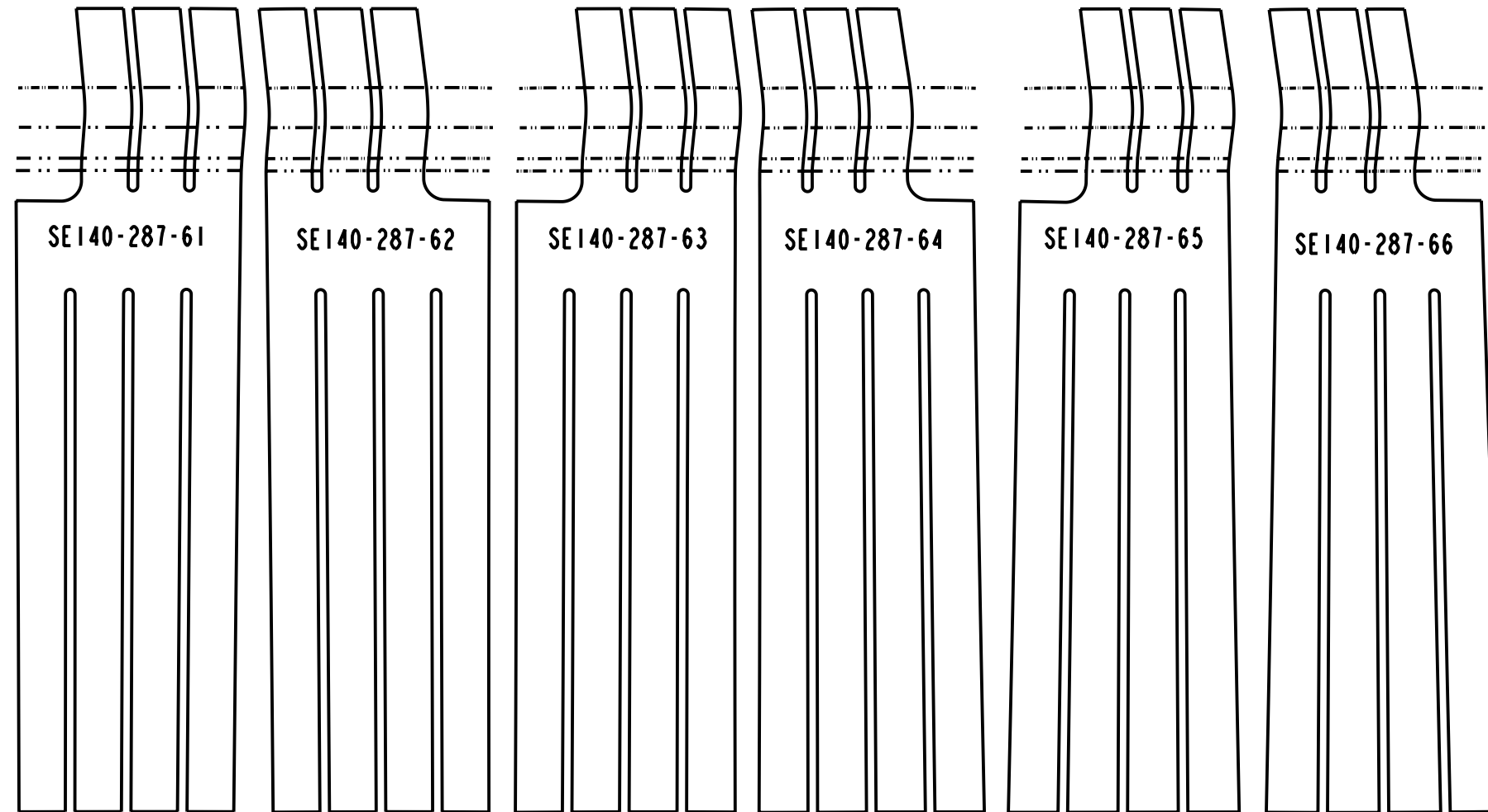



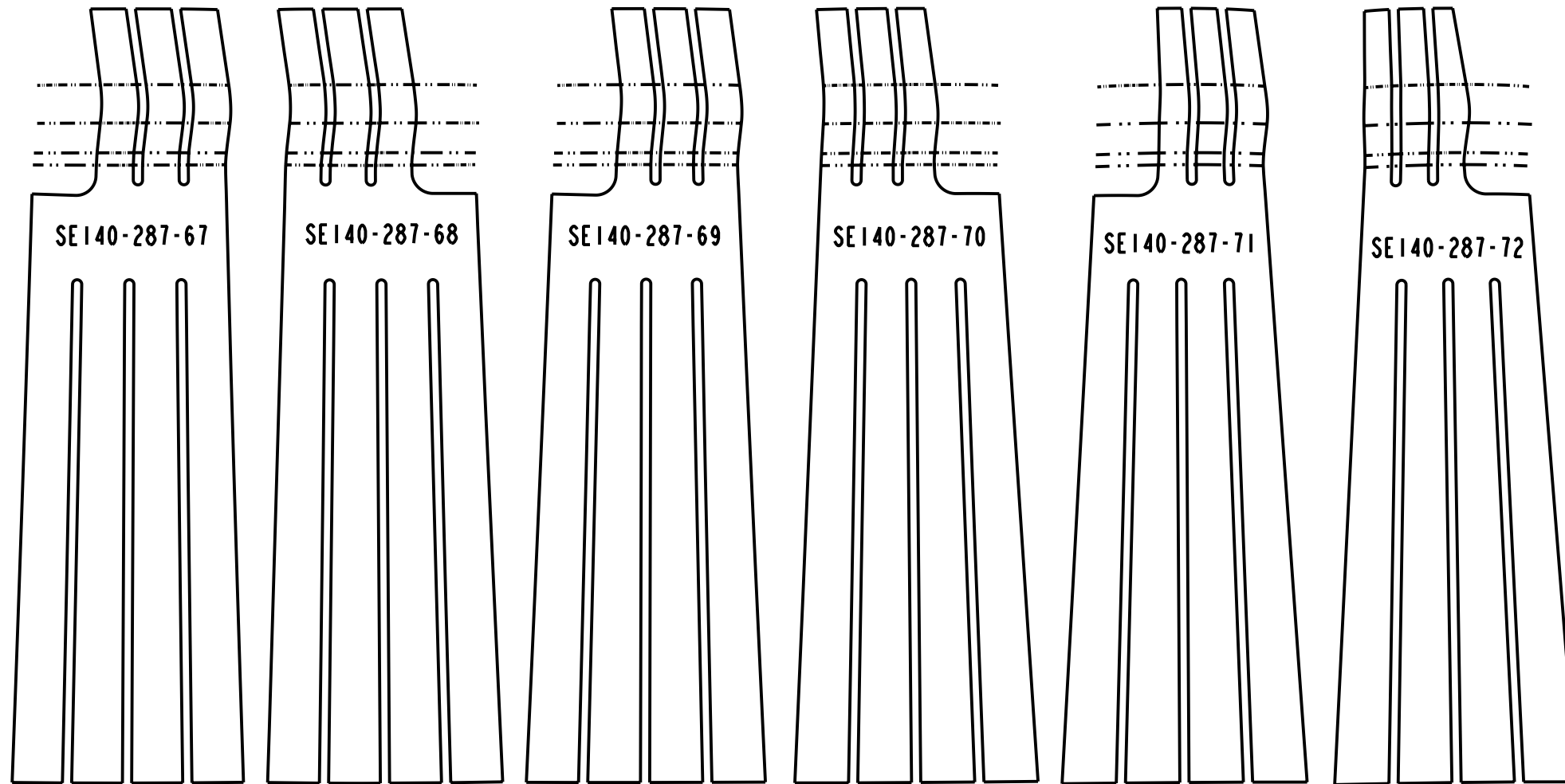

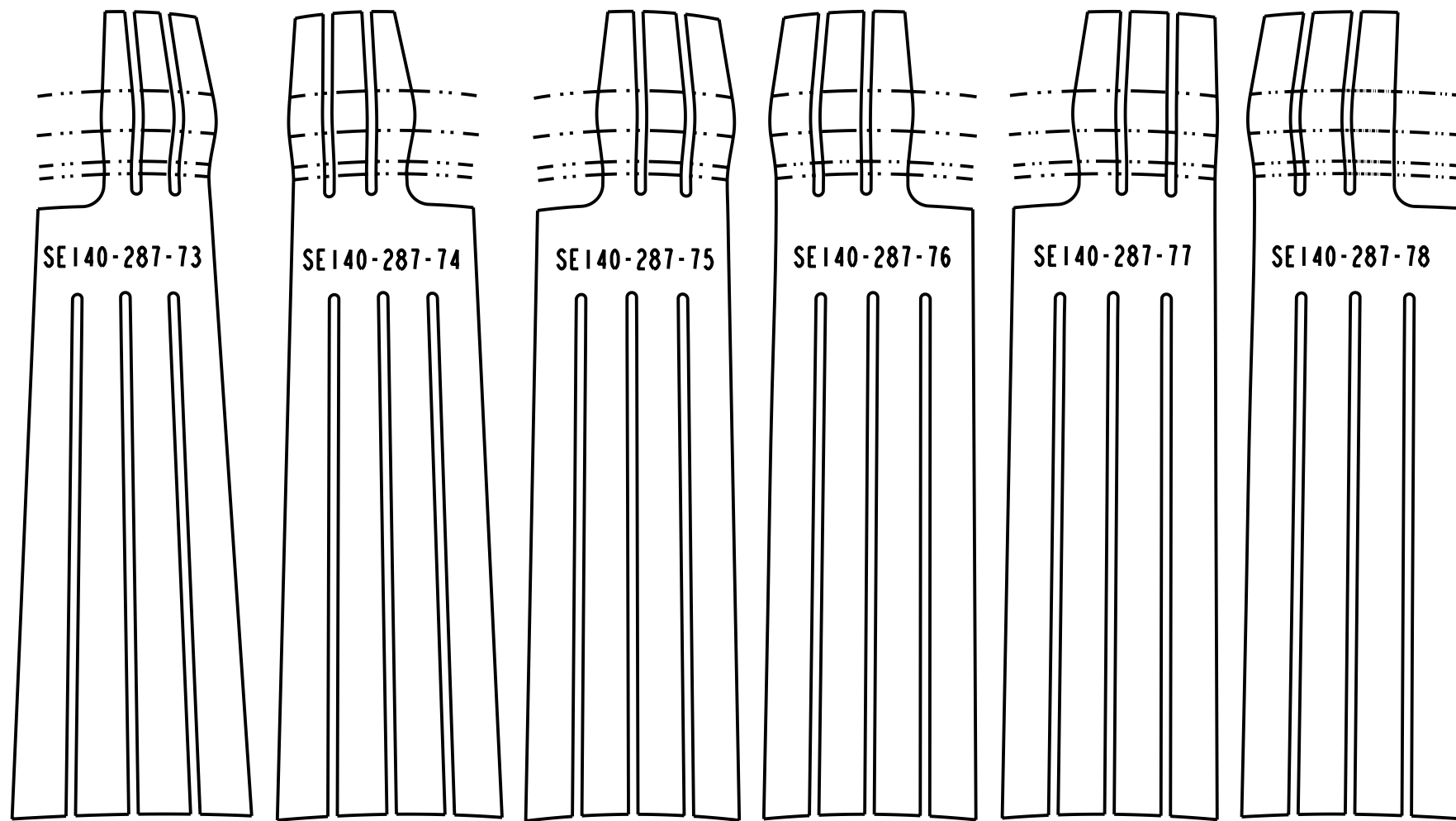

SE140-287-73

SE140-287-74

SE140-287-75

SE140-287-76

SE140-287-77

SE140-287-78

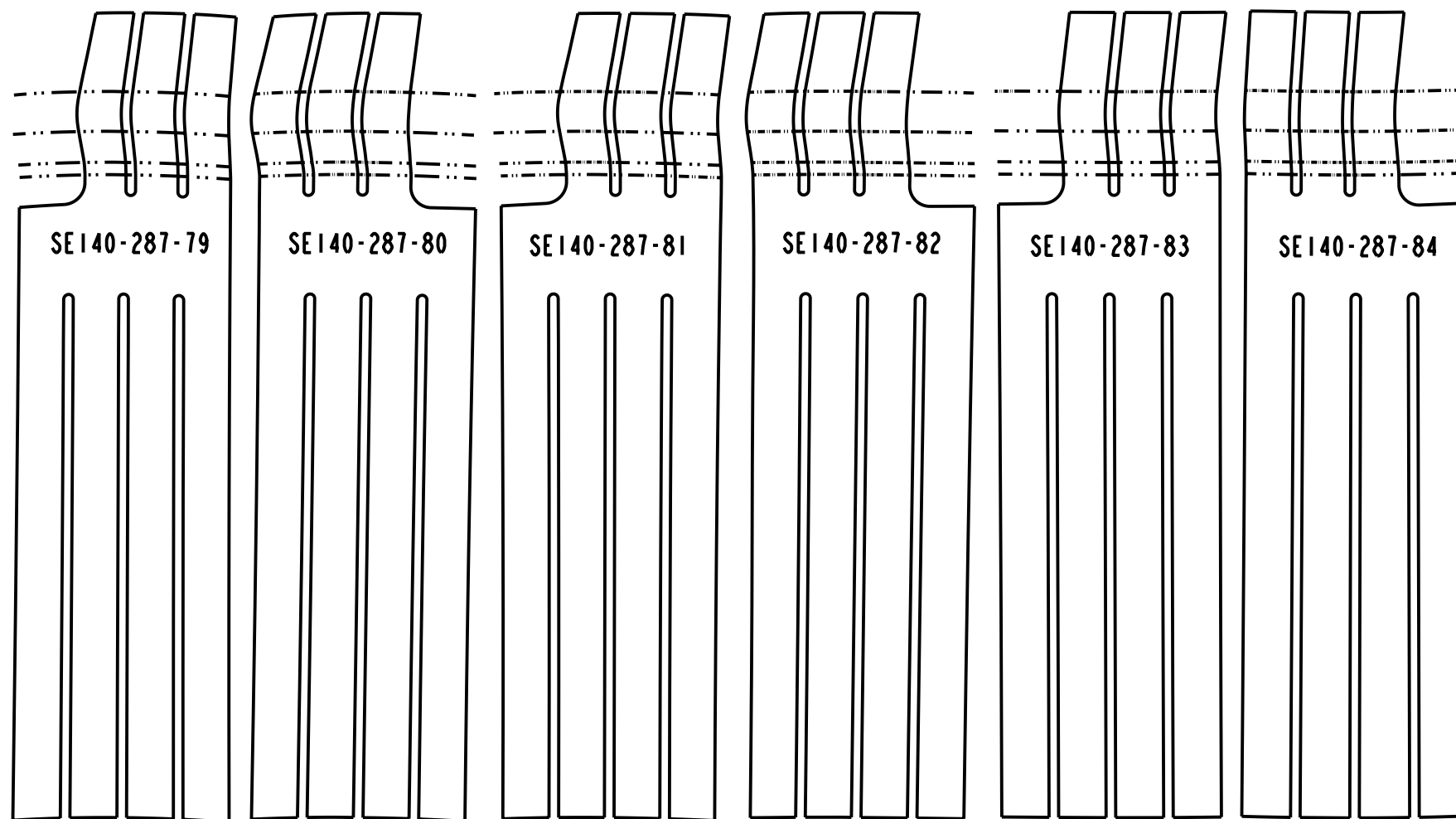

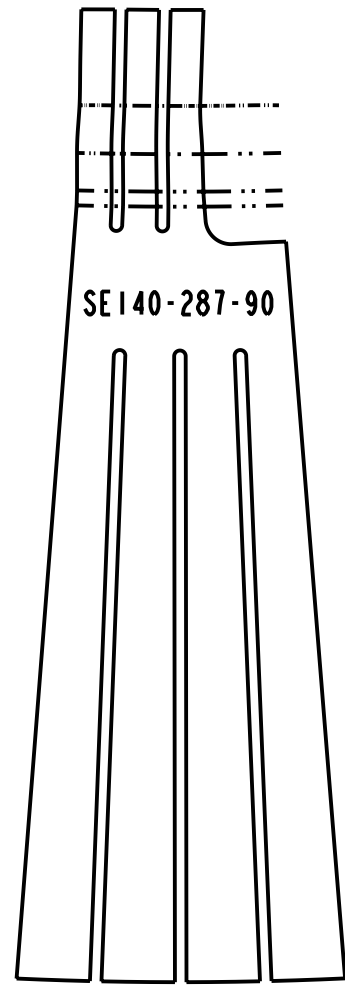
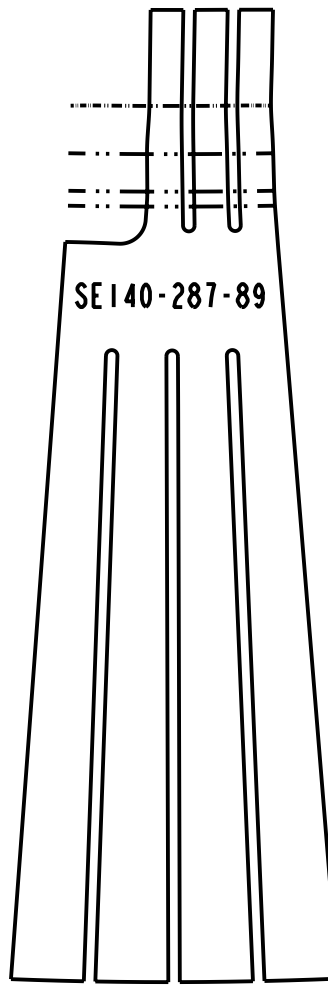
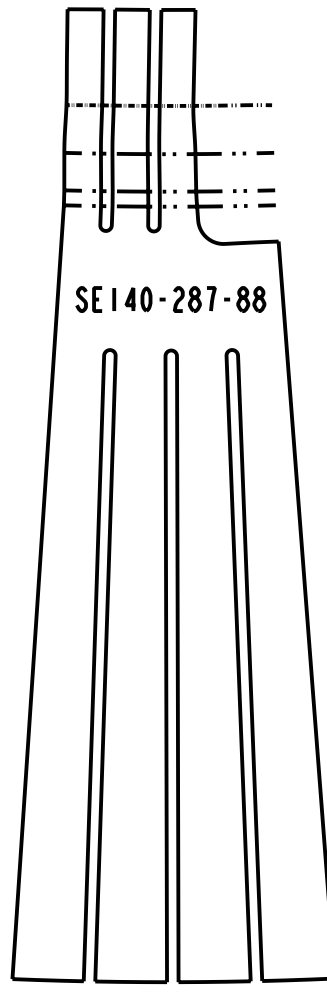
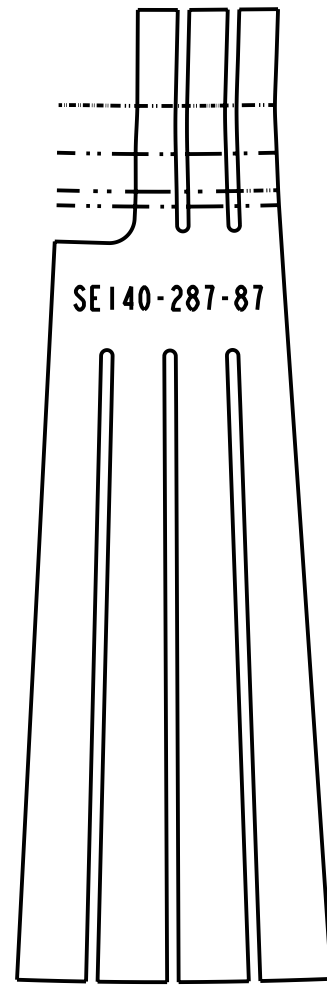
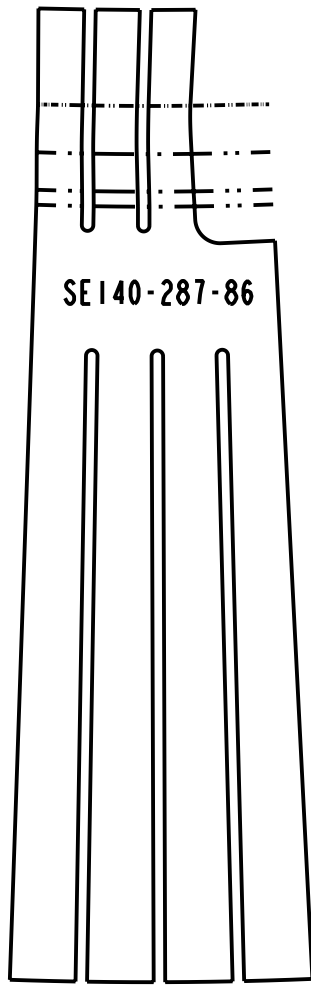
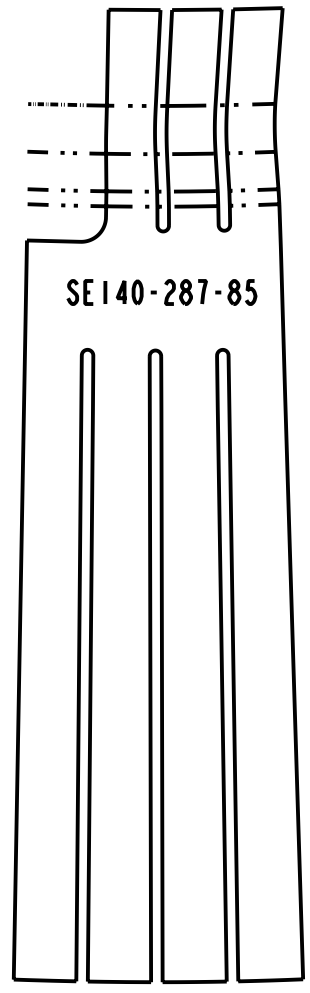

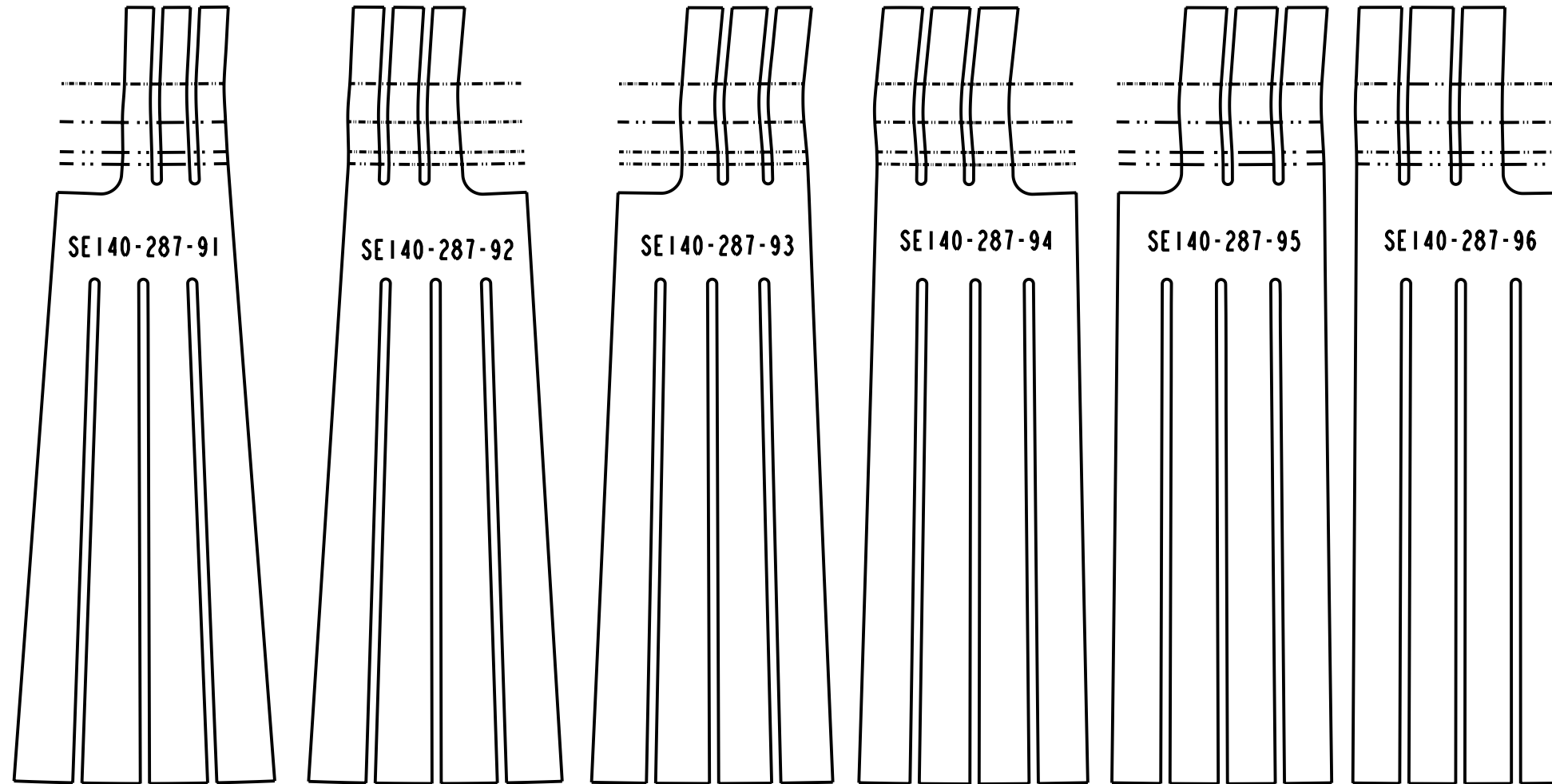

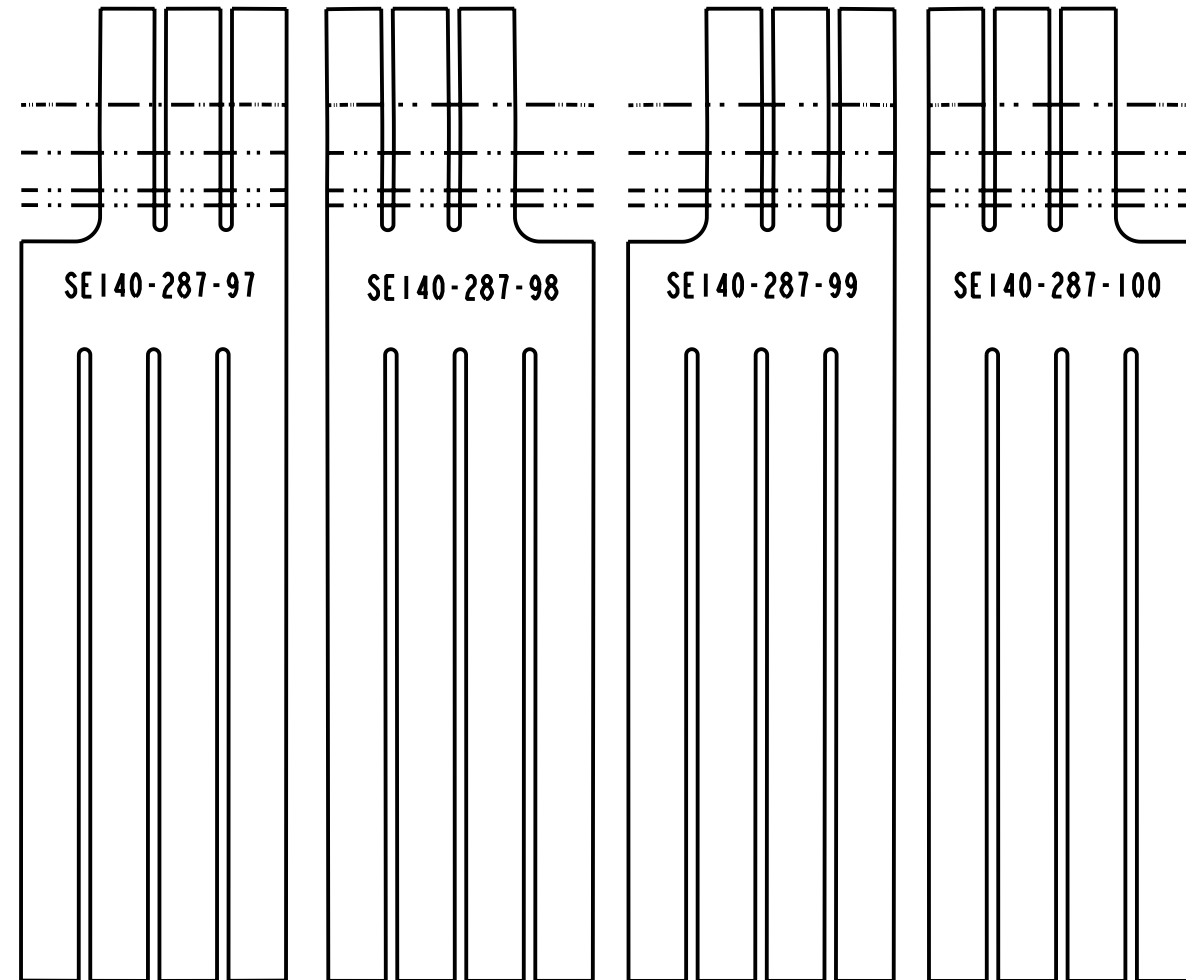

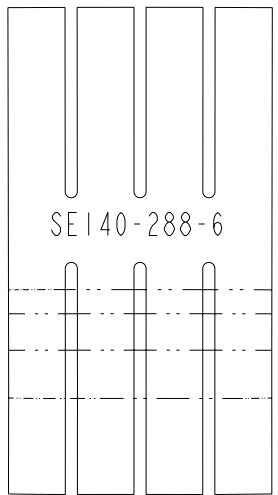
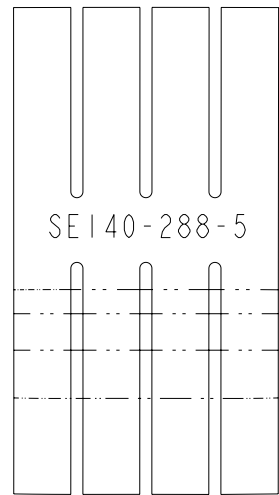
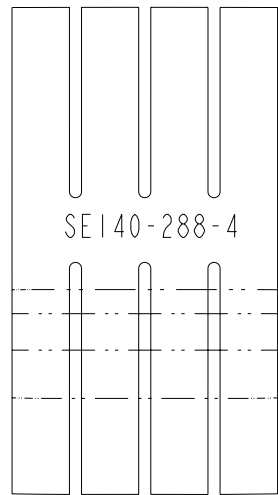
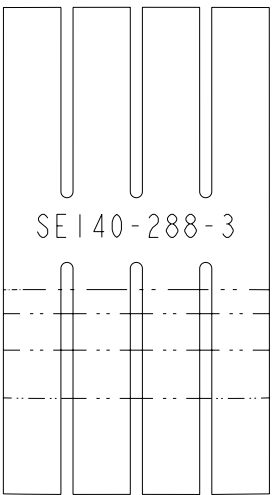
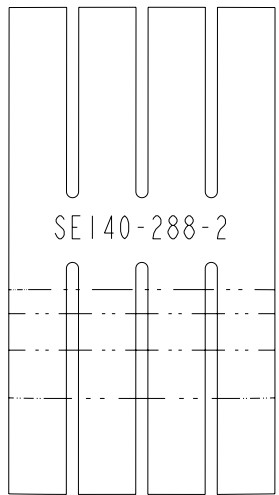
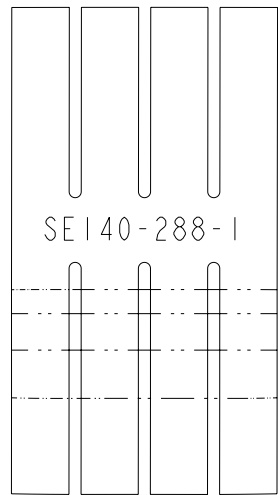

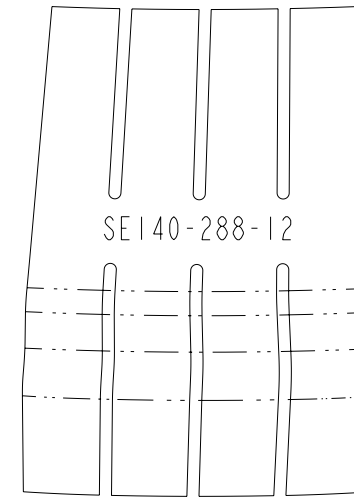
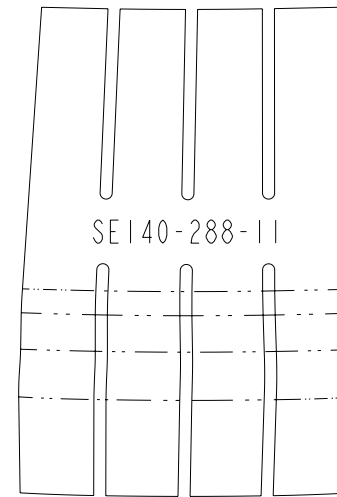
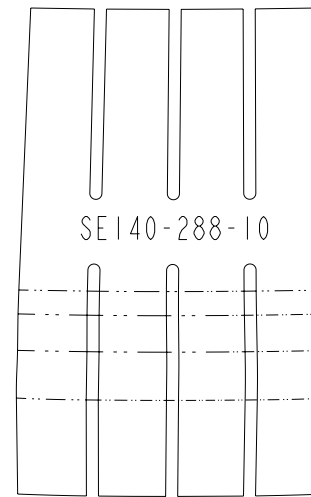
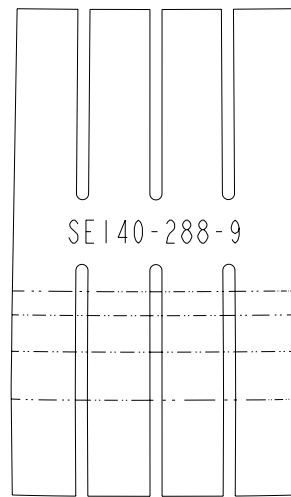
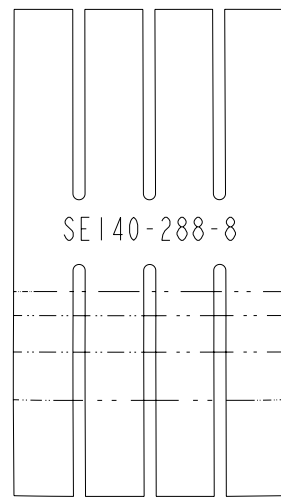
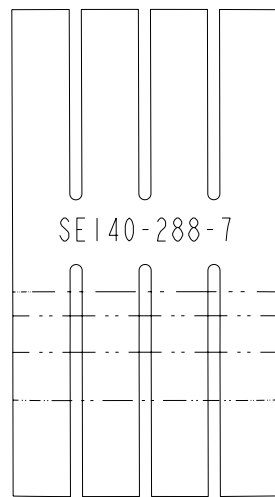



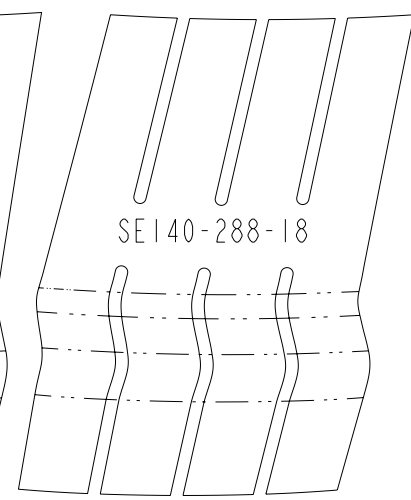
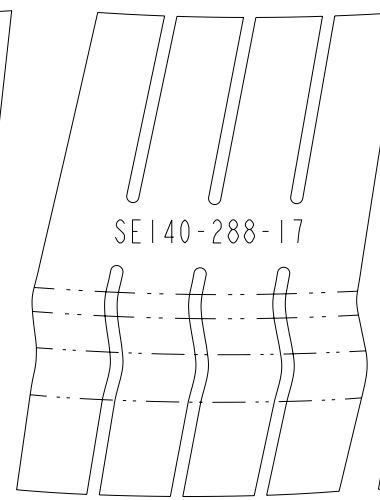
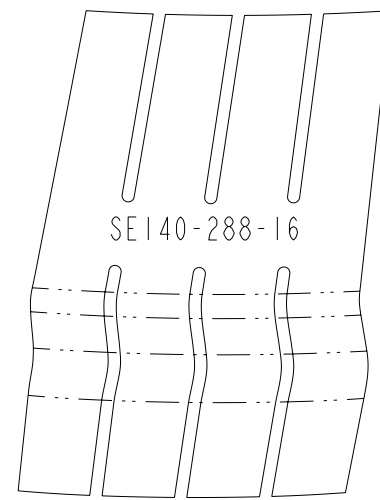
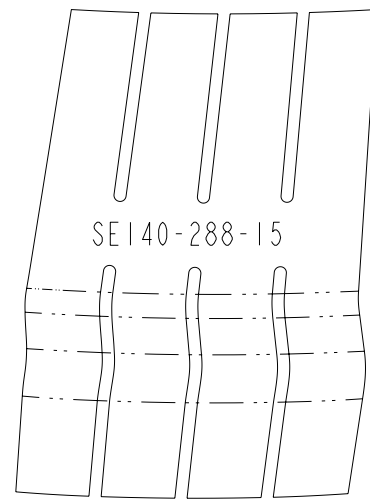
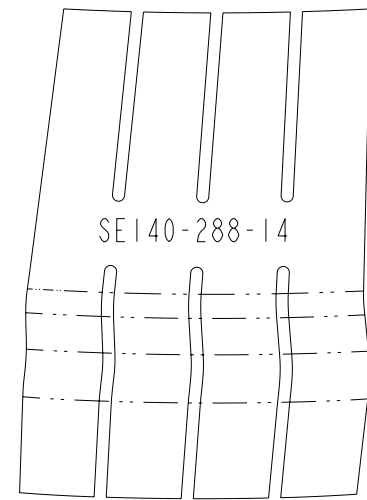
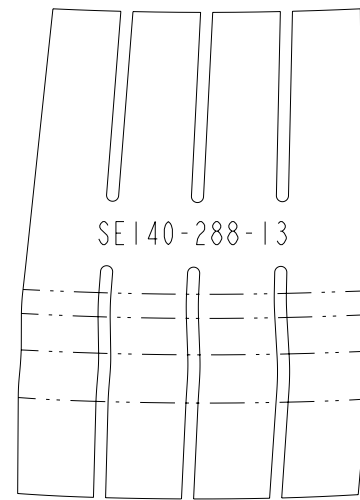

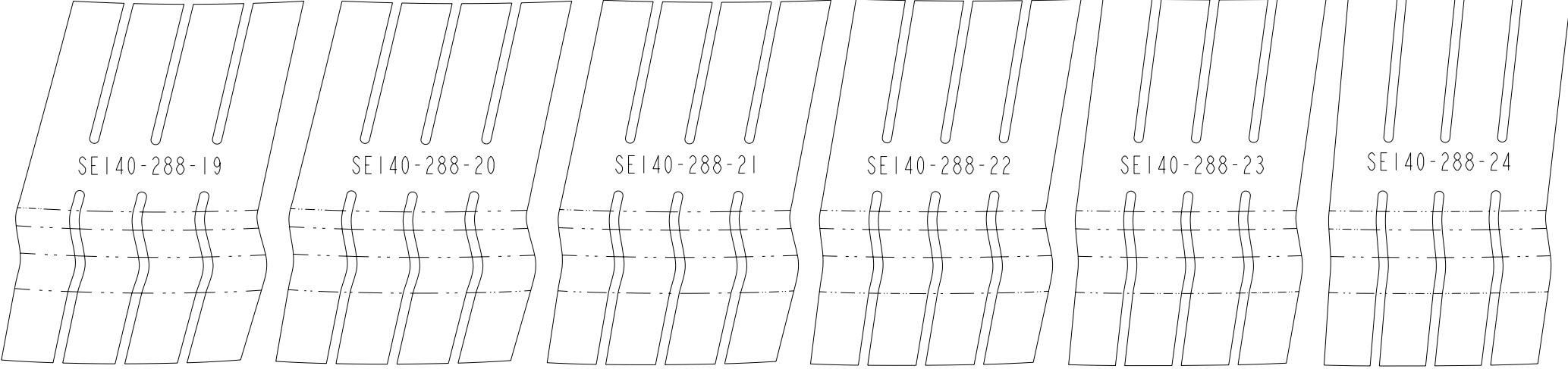

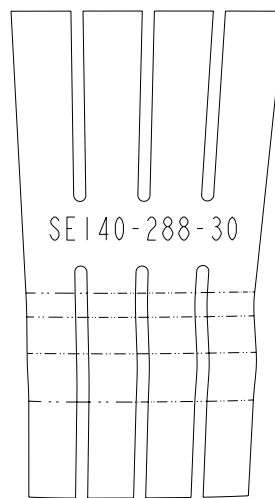
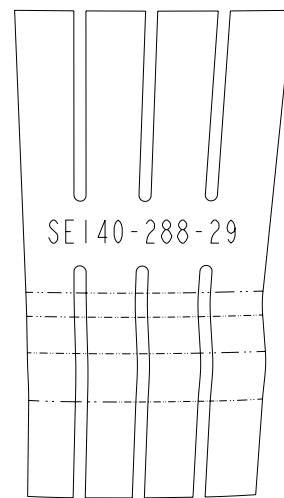
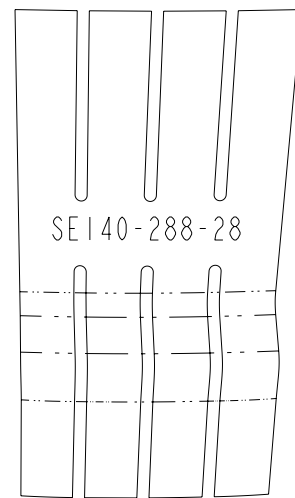
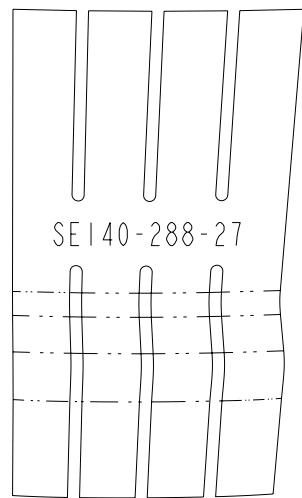
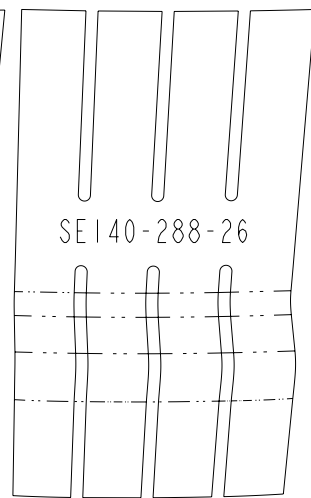
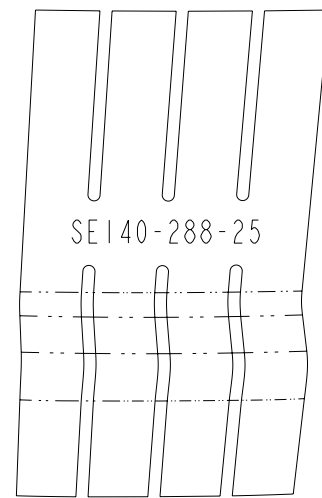

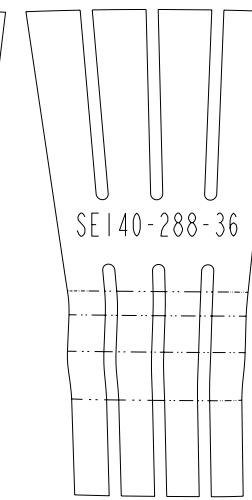
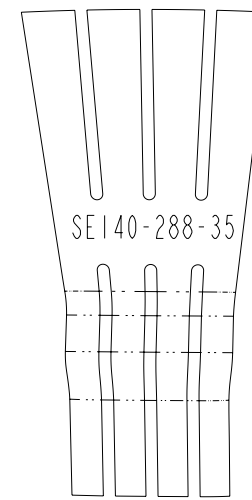
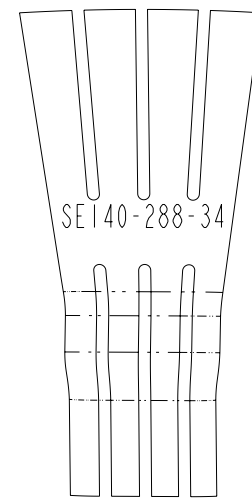
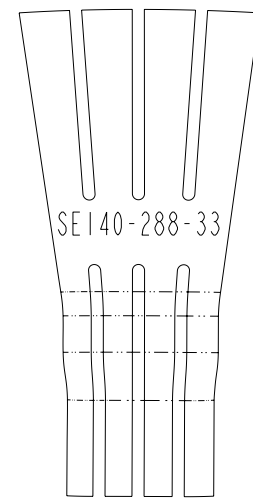
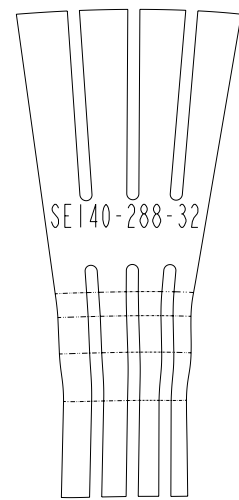
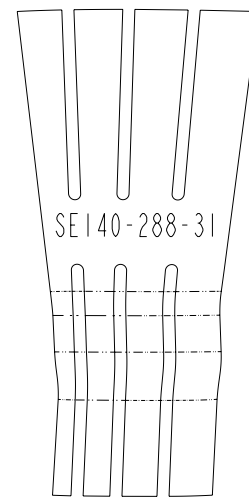

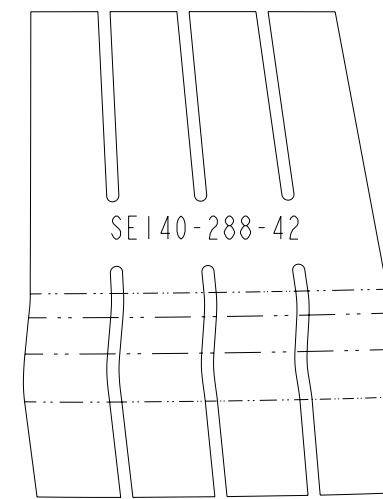
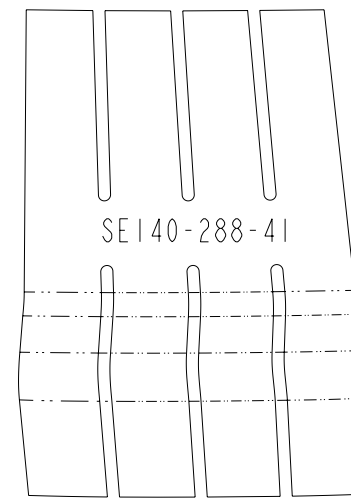
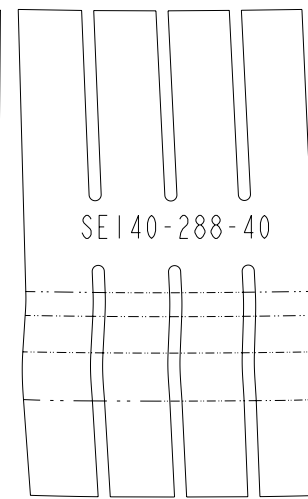
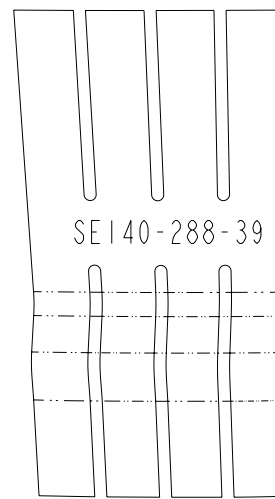
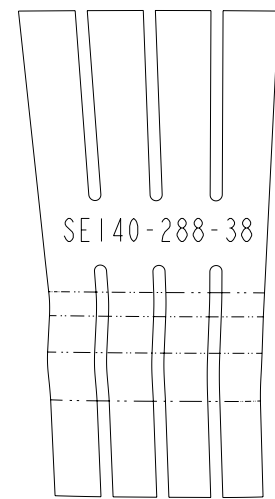
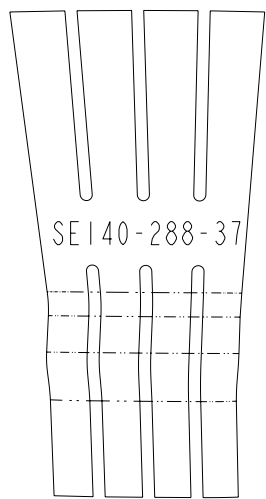

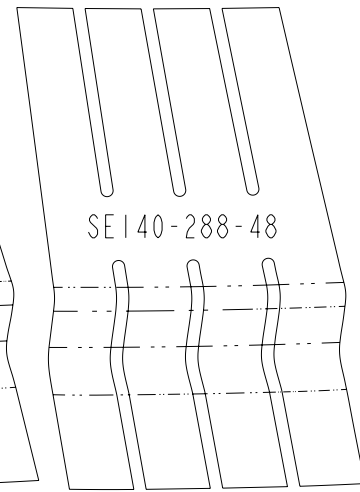
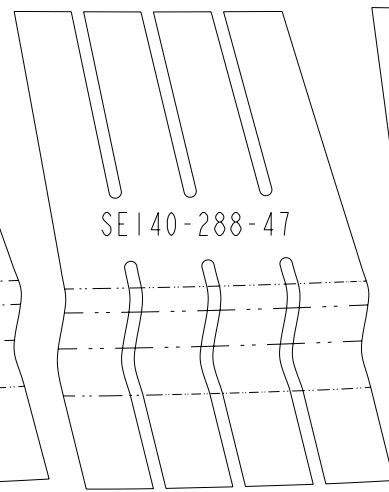
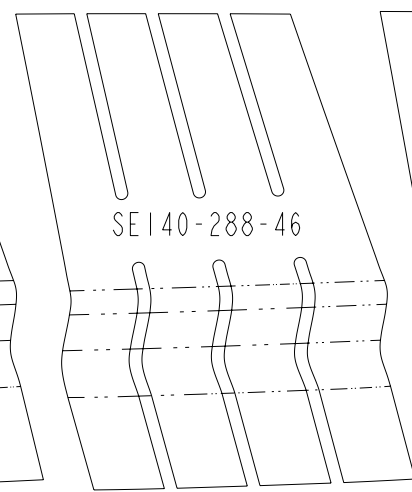
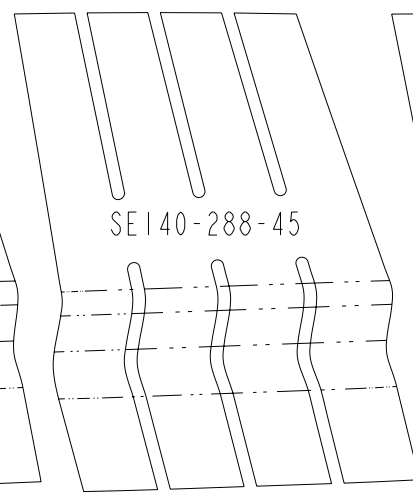
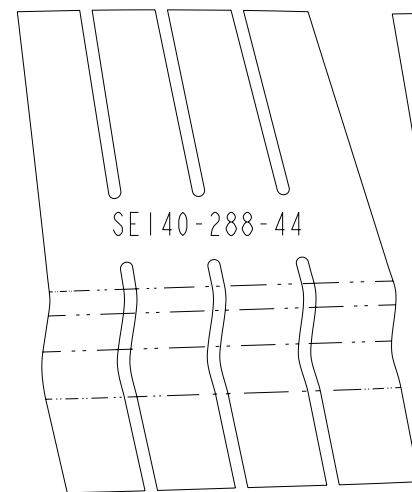
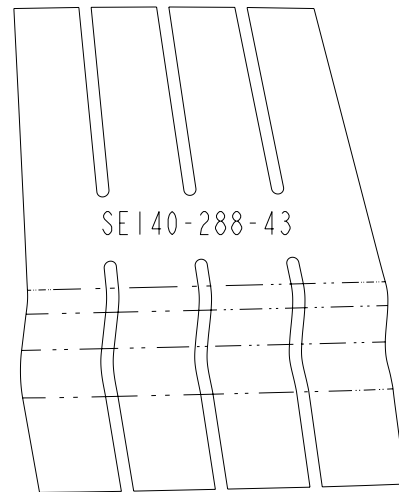

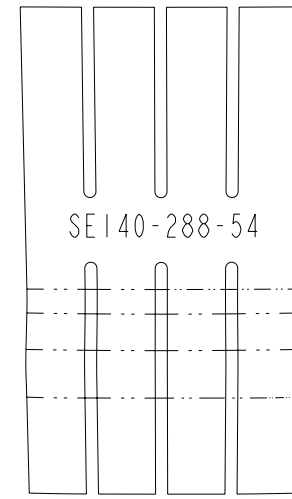
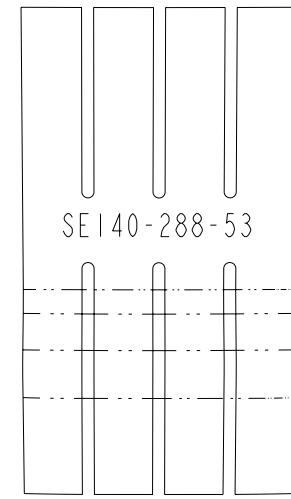
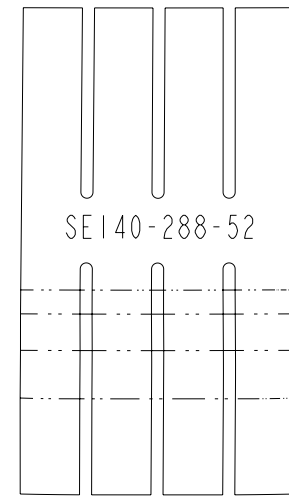
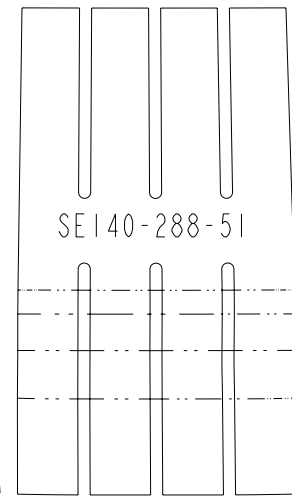
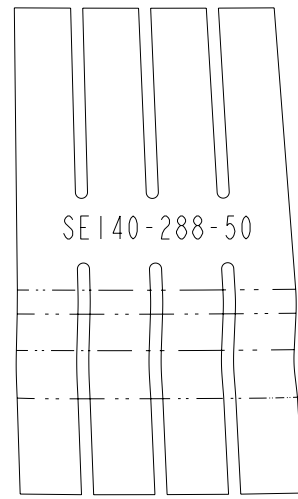
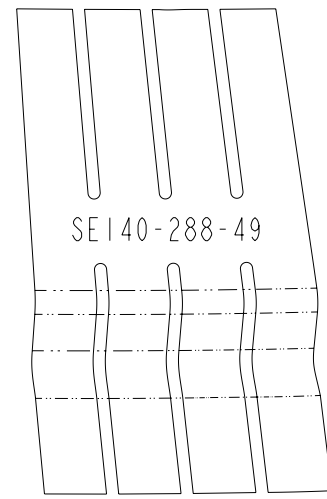

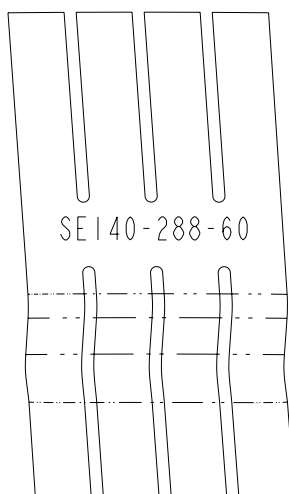
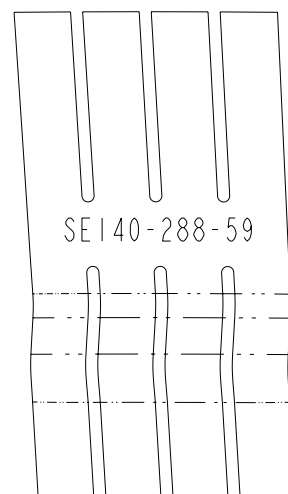
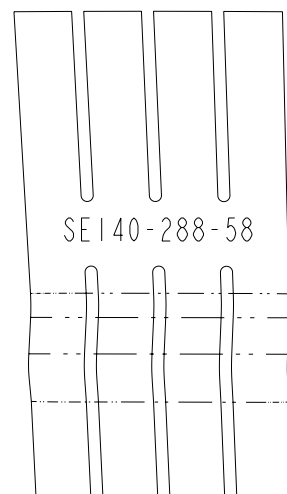
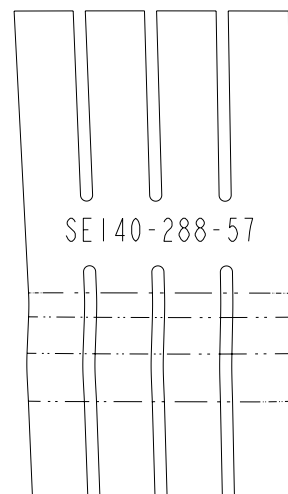
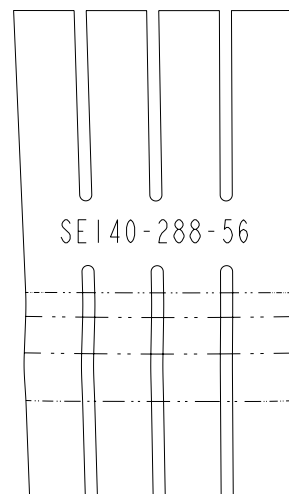
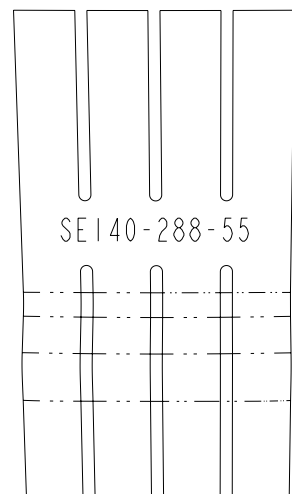



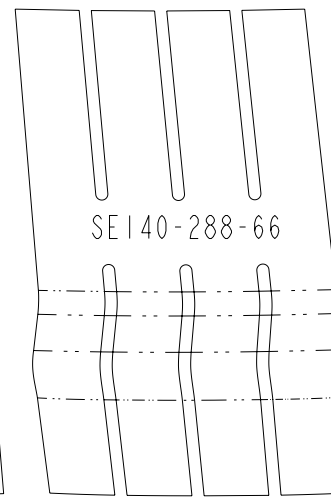
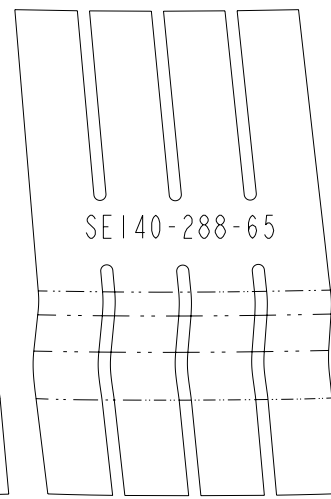
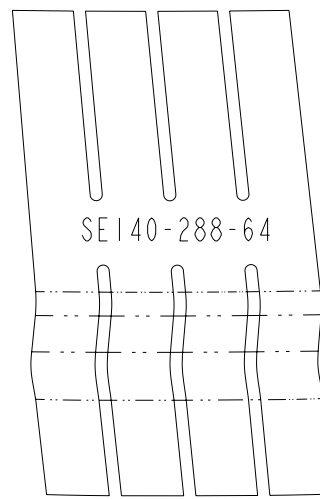
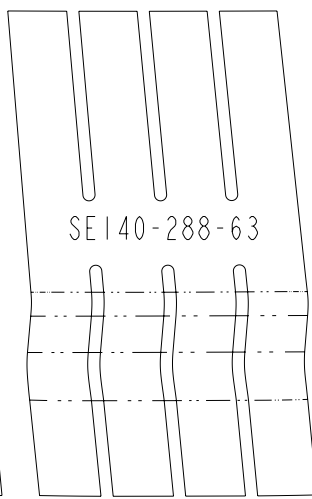
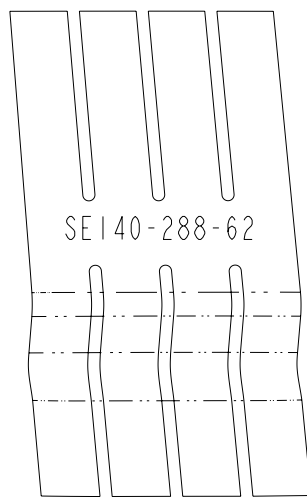
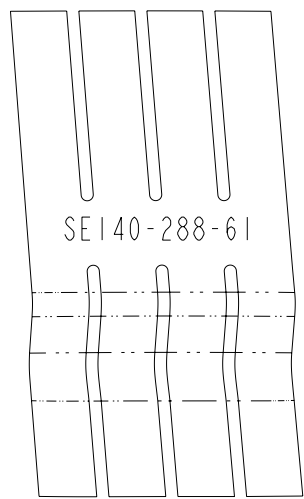

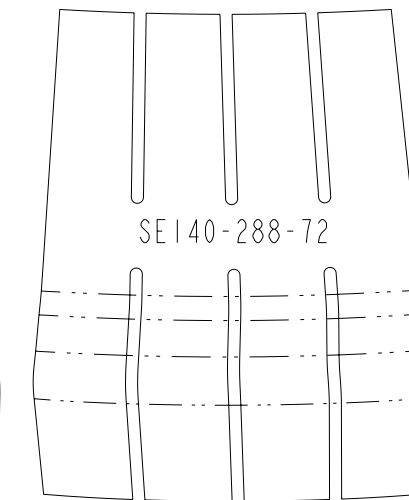
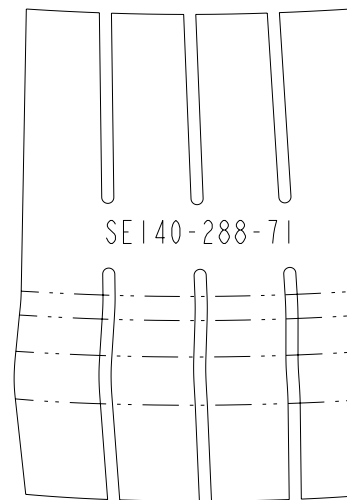
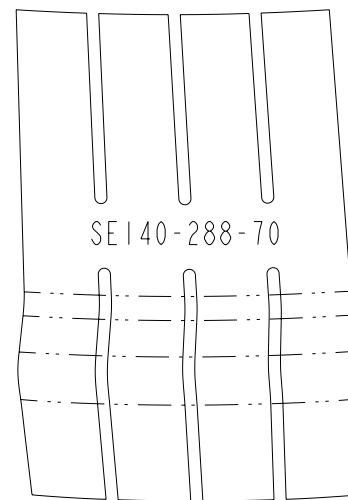
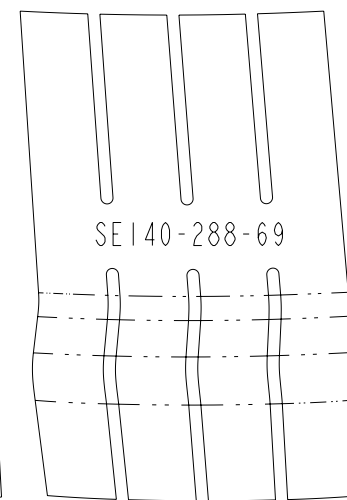
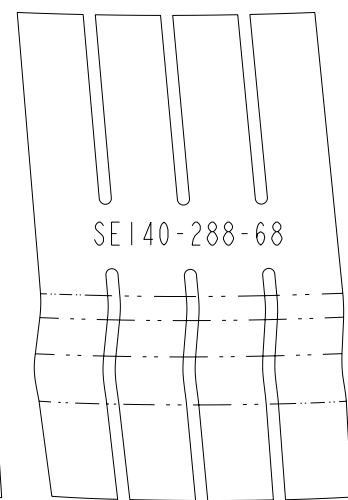
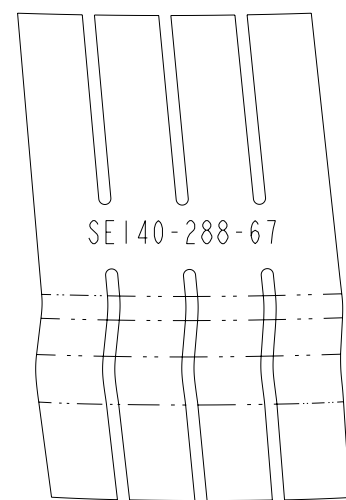

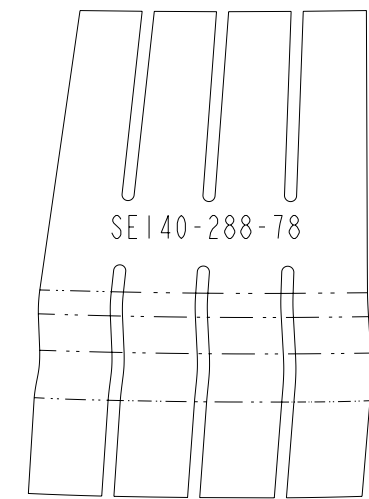
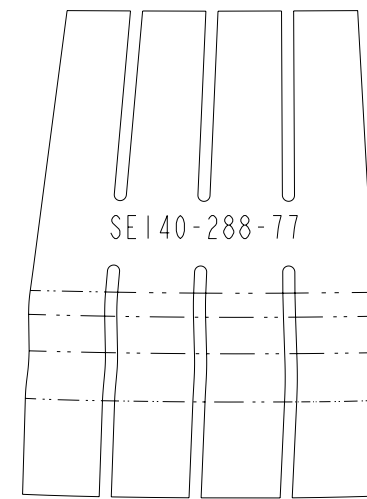
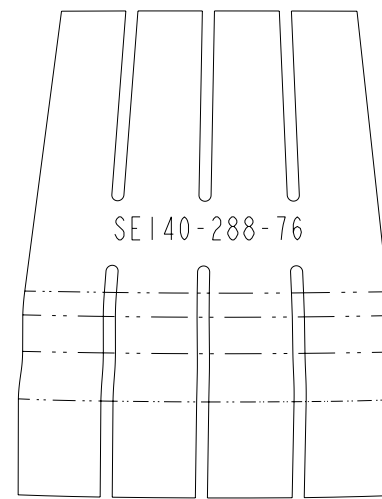
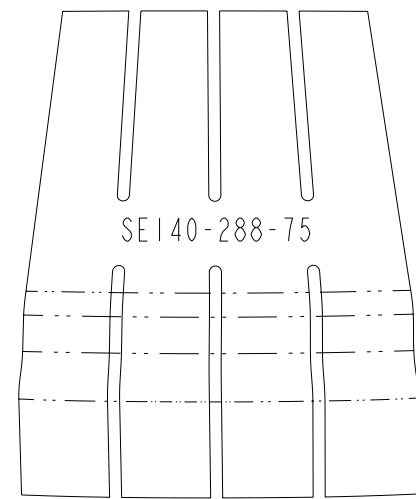
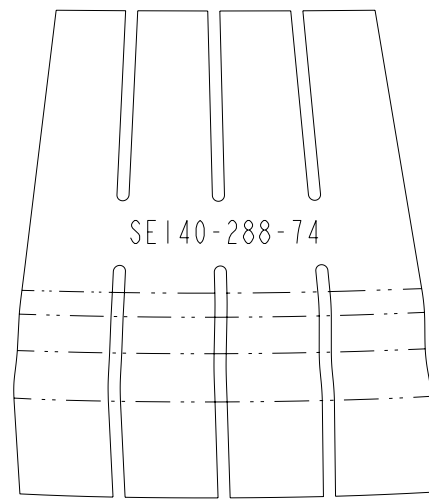
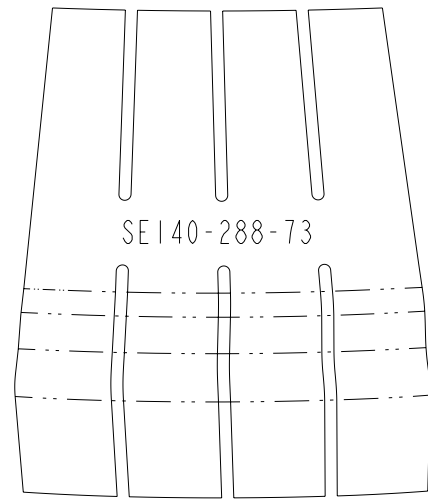

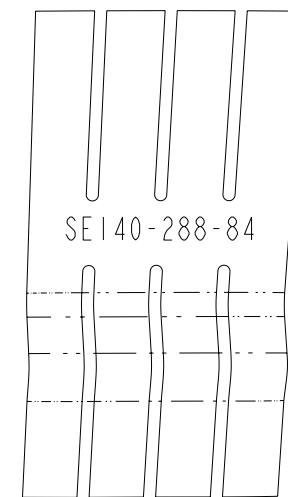
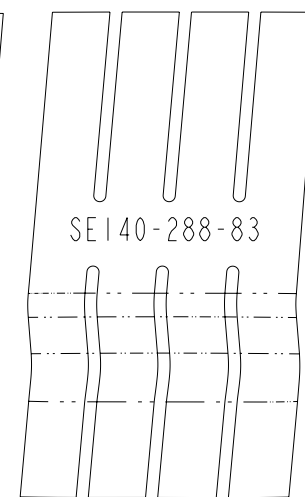
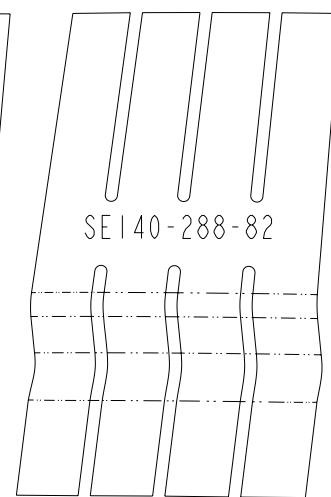
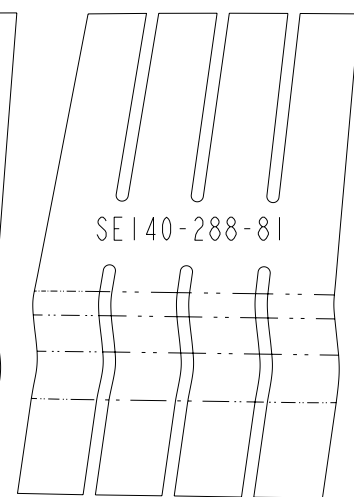
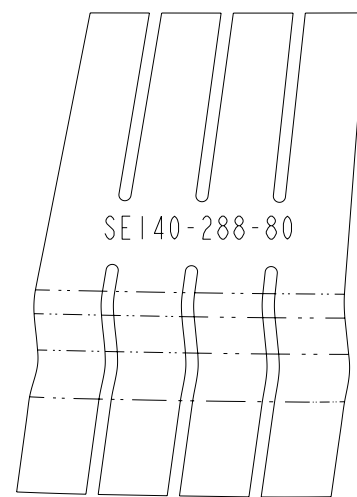
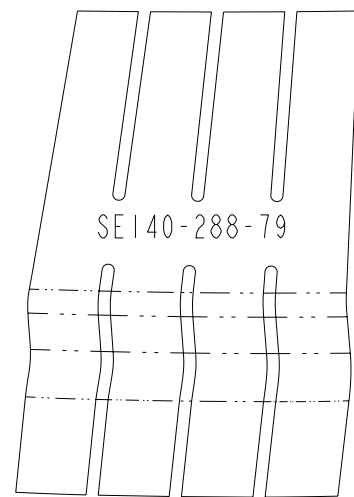

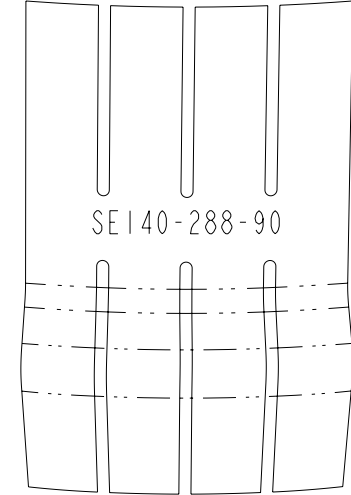
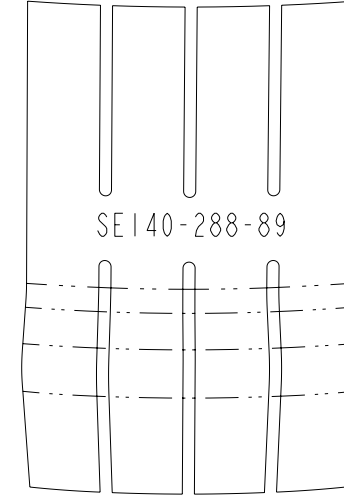
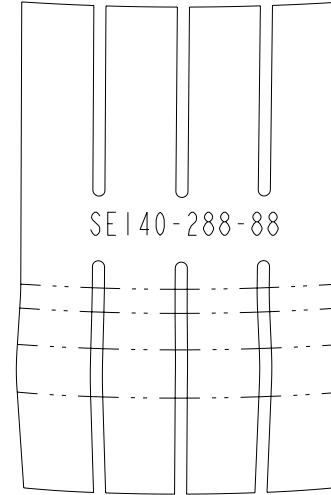
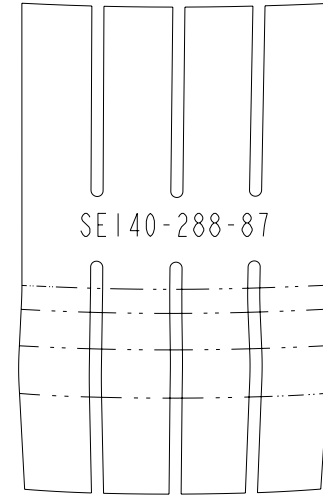
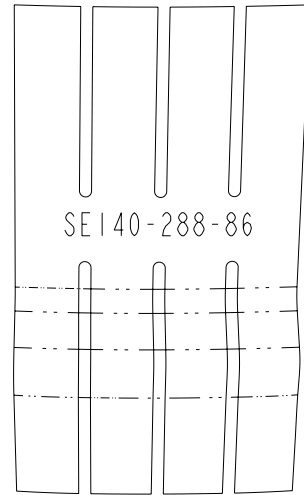
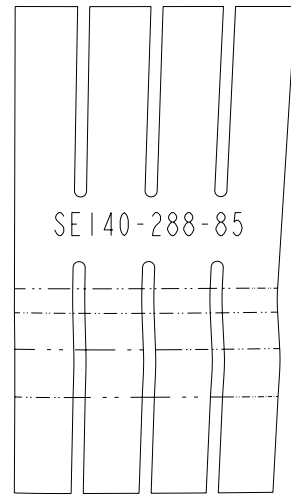

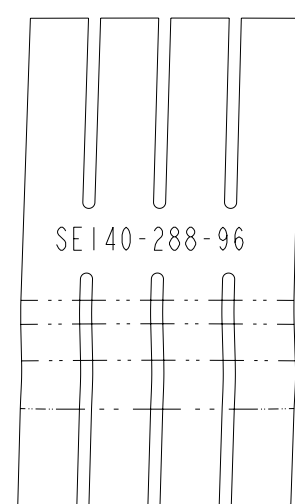
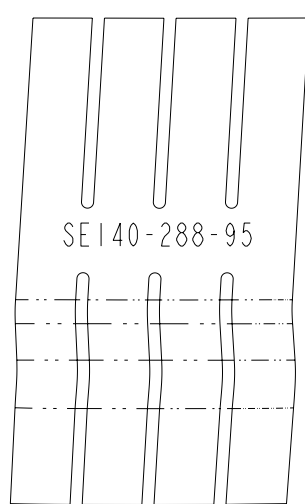
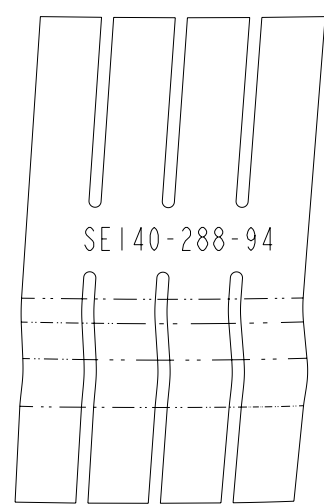
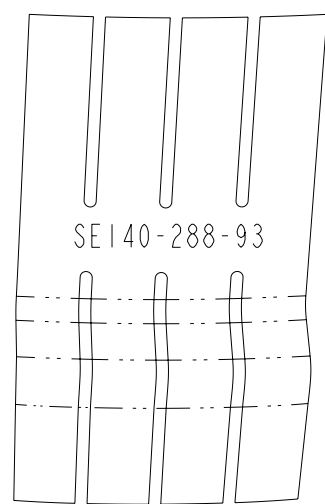
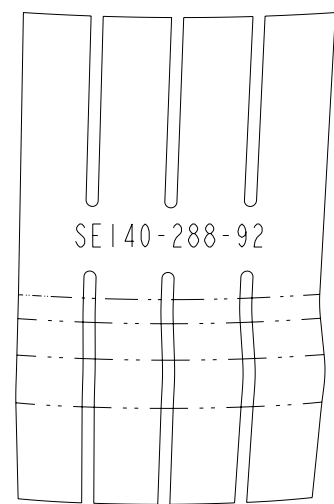
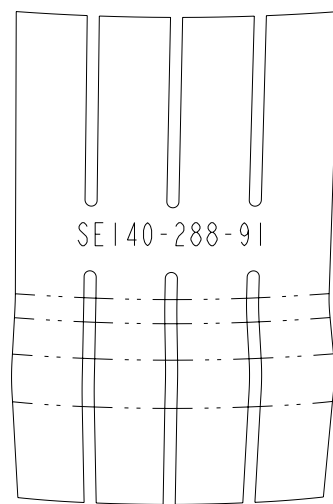

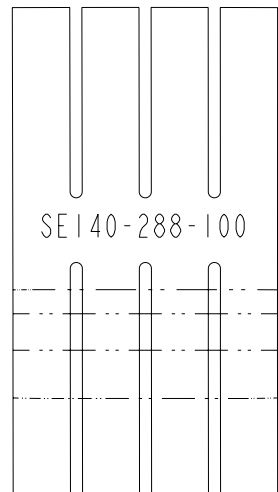
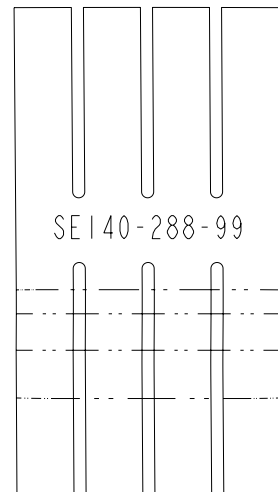
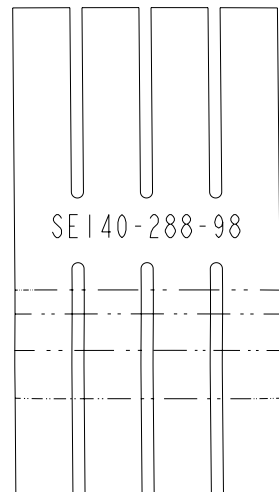
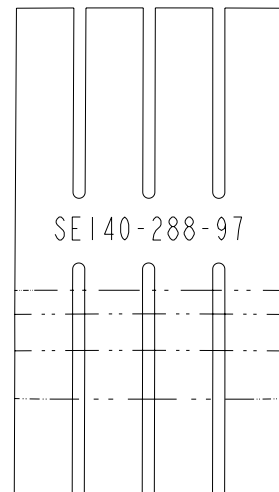

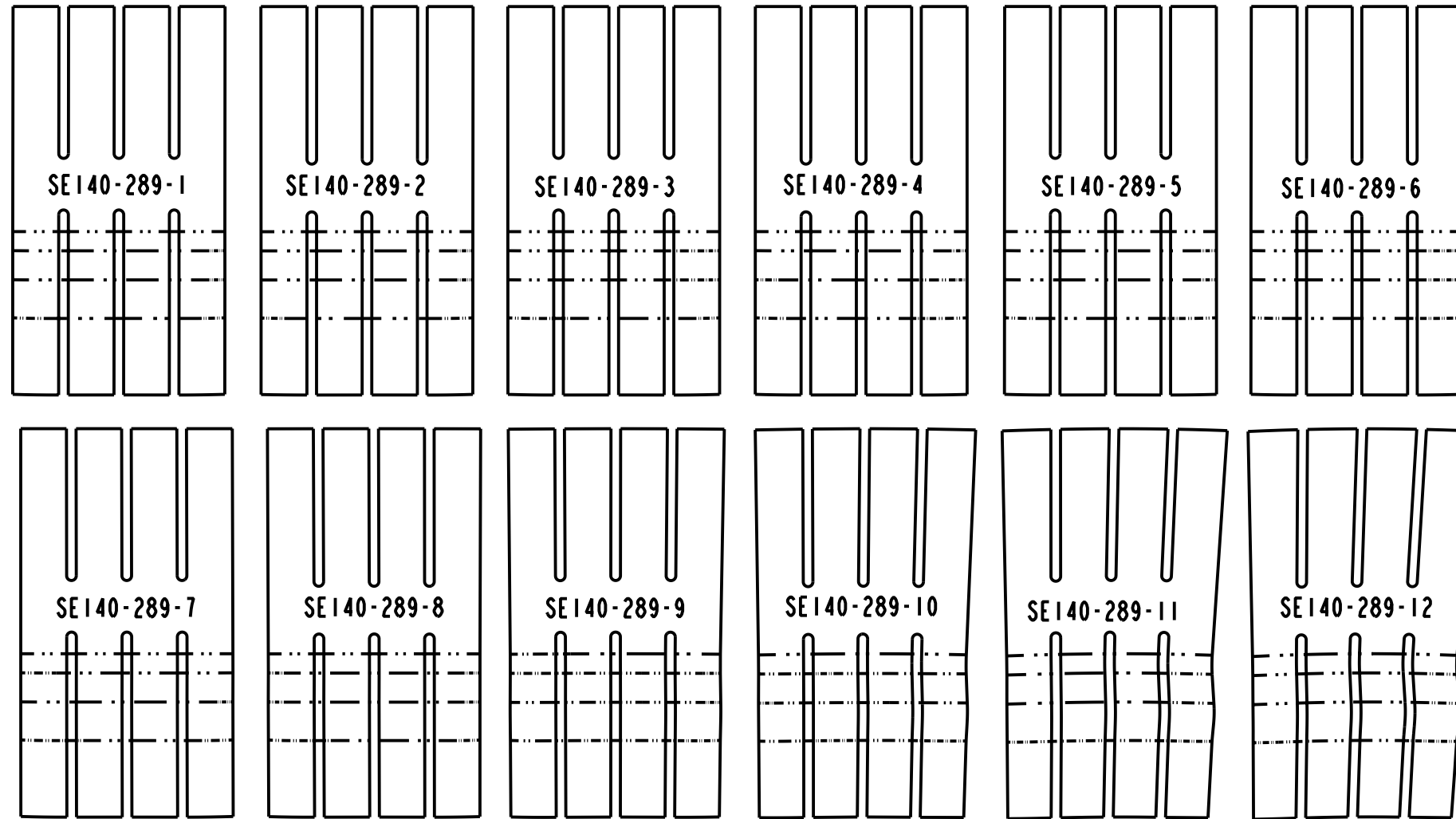



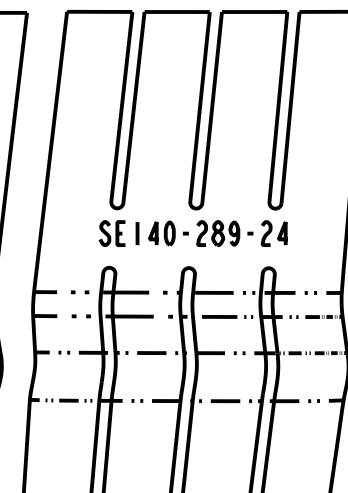
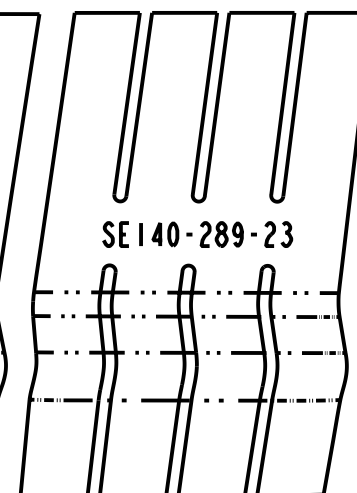
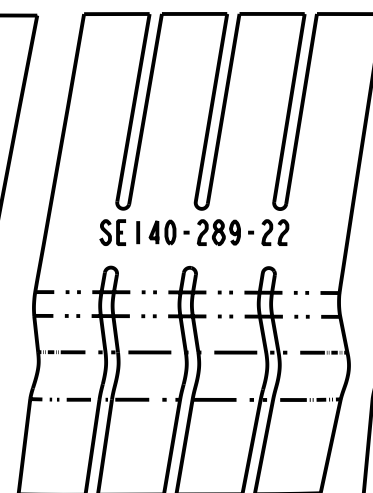
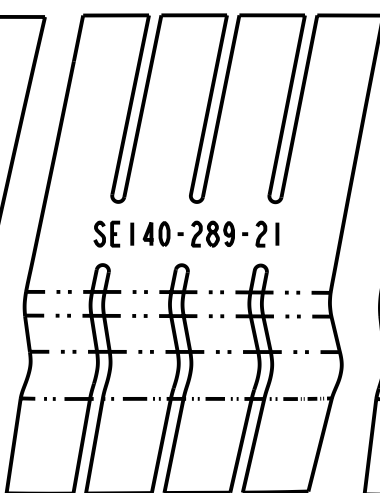
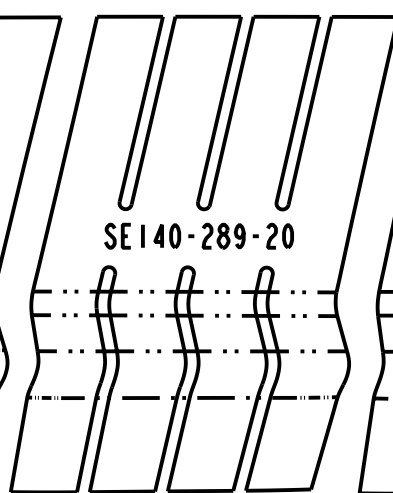
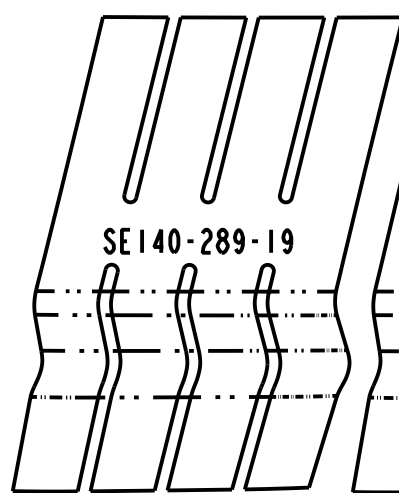
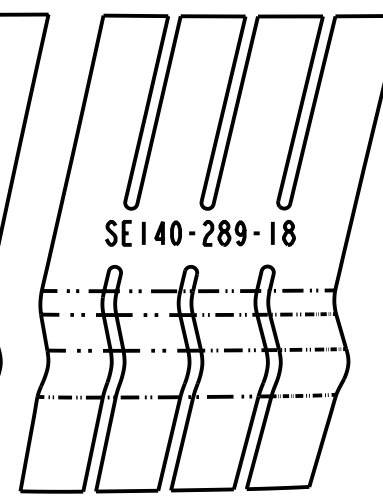
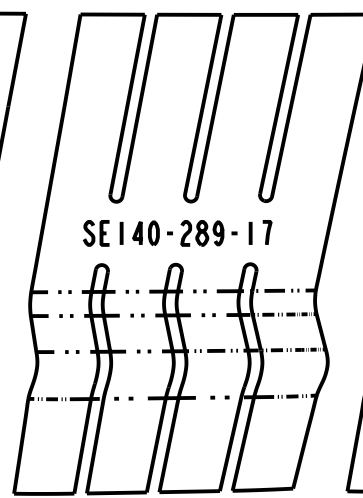
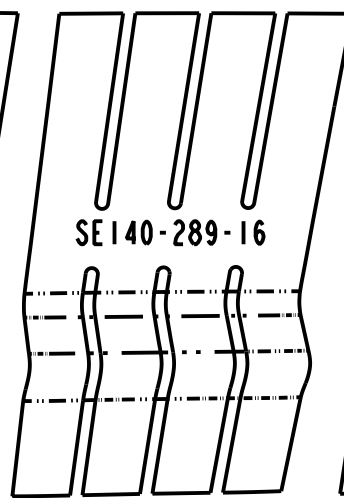
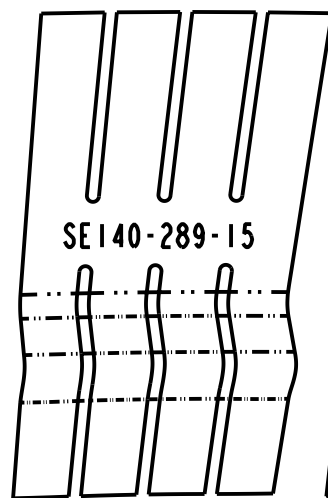
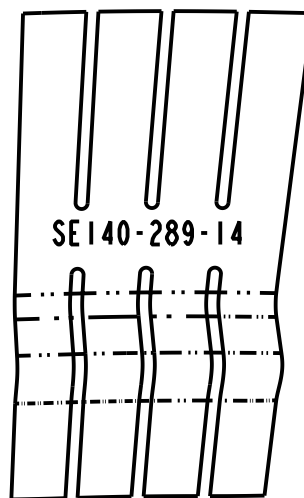
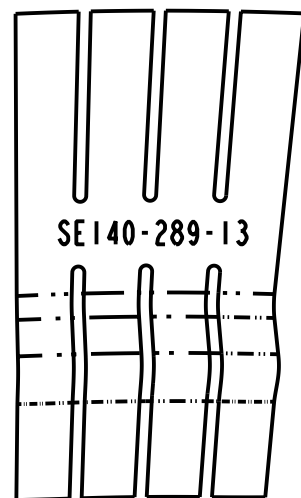



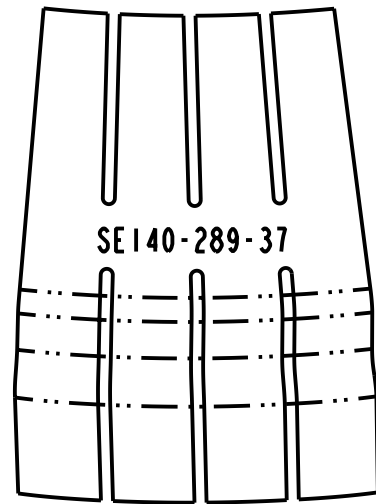

SE140-289-37

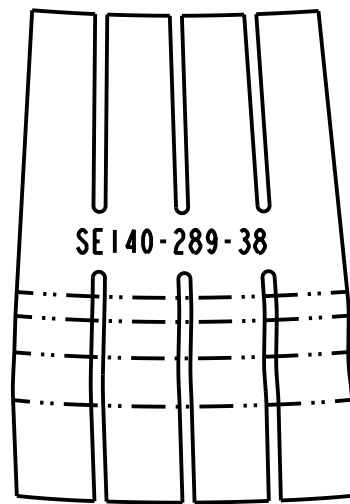

SE140-289-38

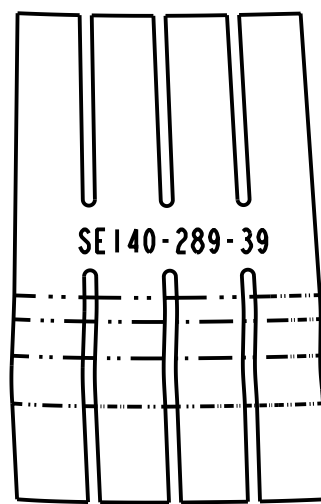

SE140-289-39

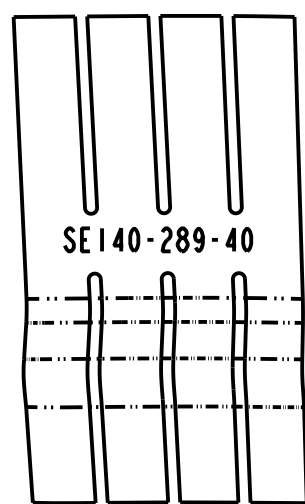

SE140-289-40

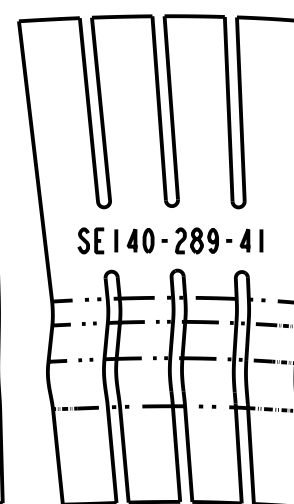

SE140-289-41

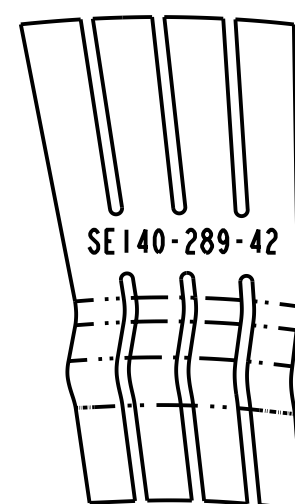

SE140-289-42

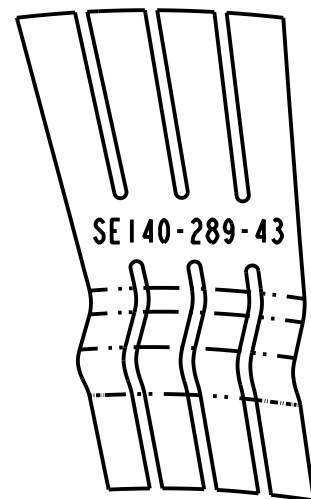

SE140-289-43

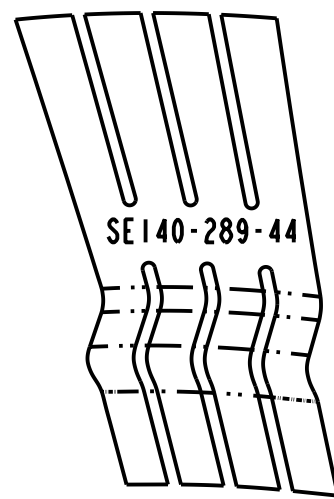

SE140-289-44

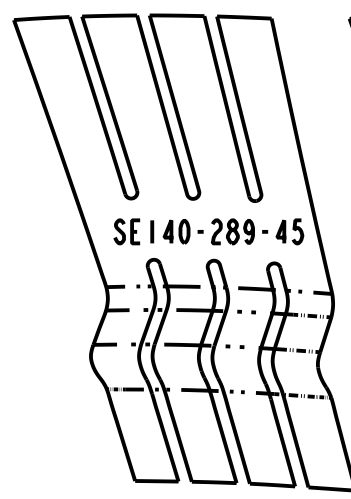

SE140-289-45

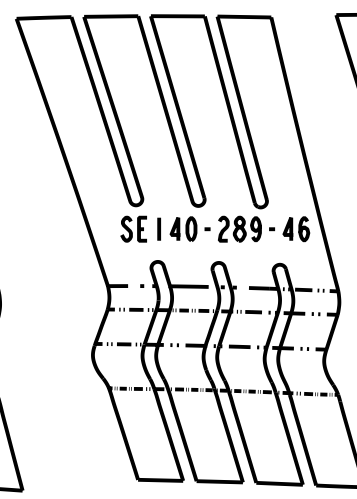

SE140-289-46

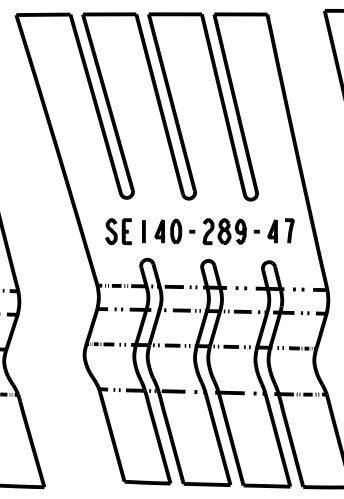

SE140-289-47

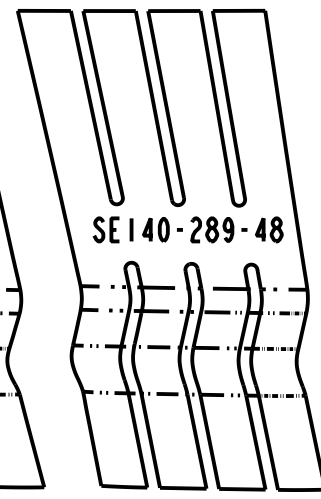

SE140-289-48

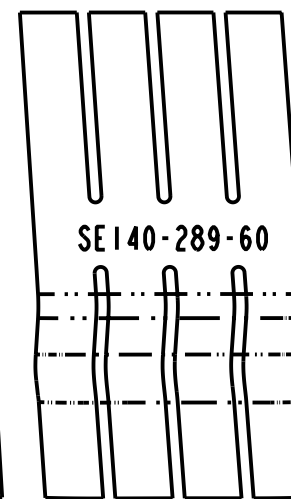
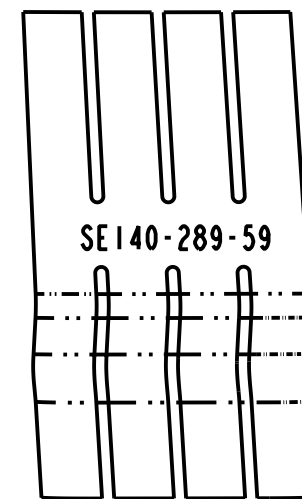
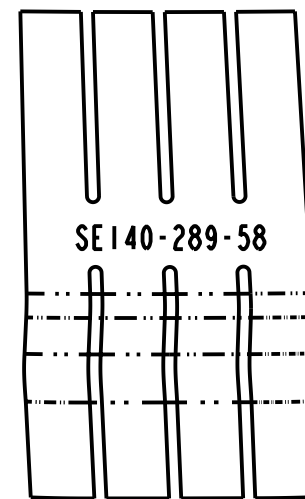
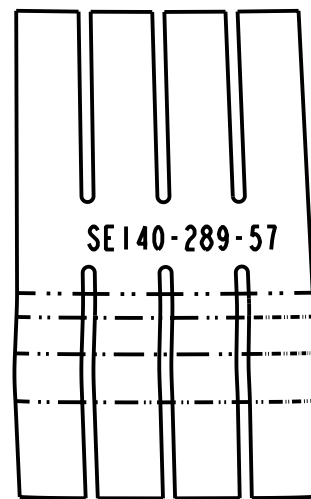
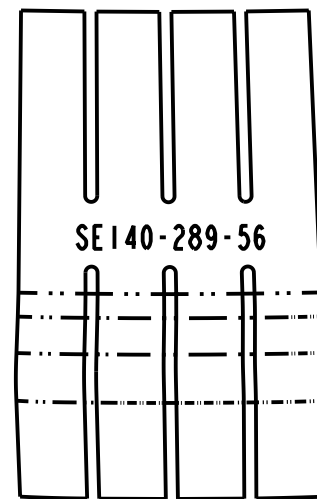
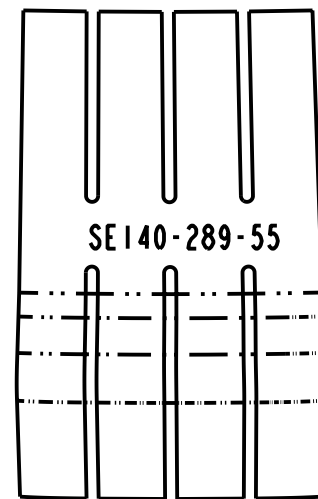
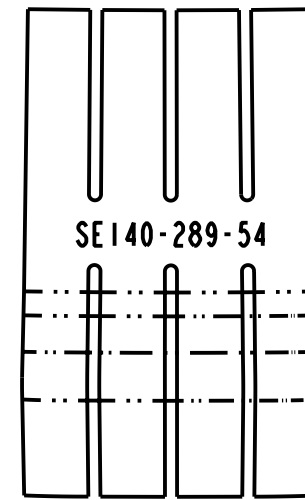
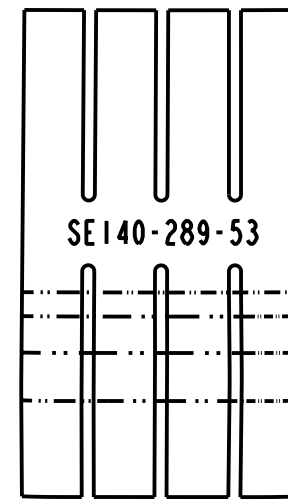
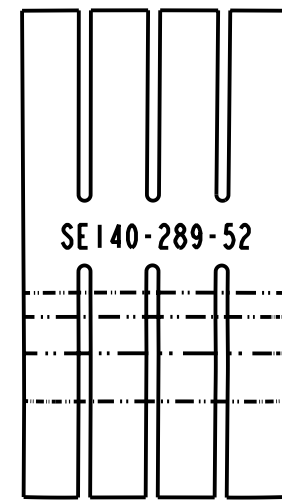
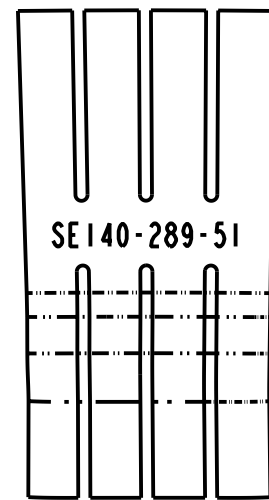
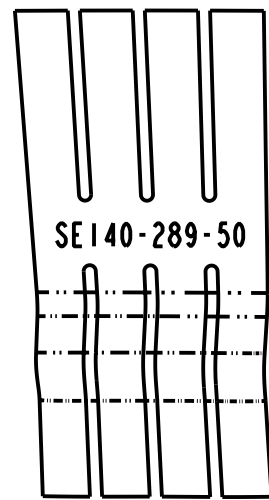
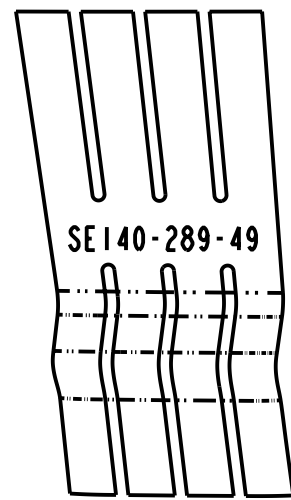

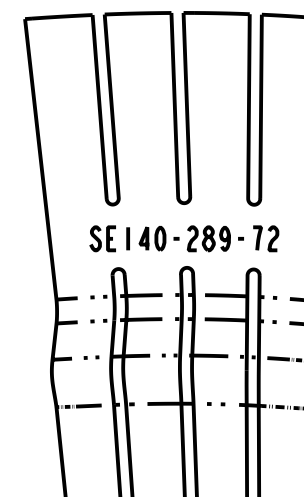
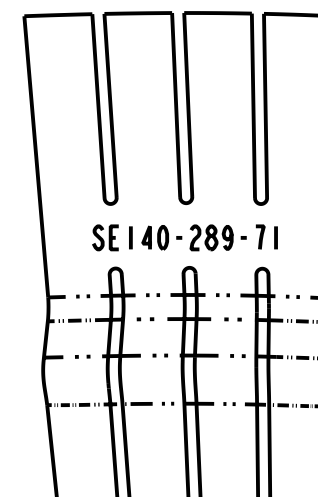
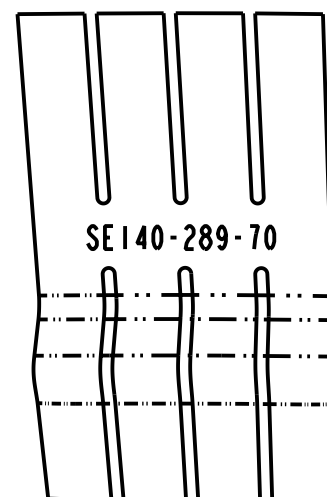
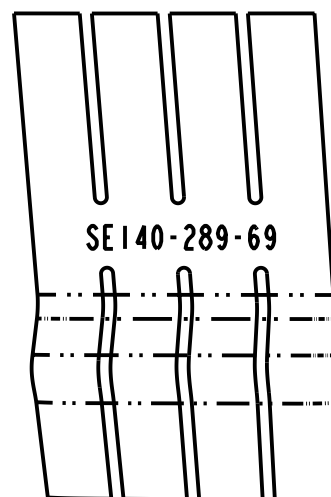
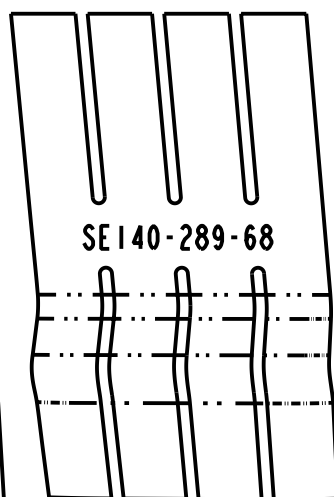
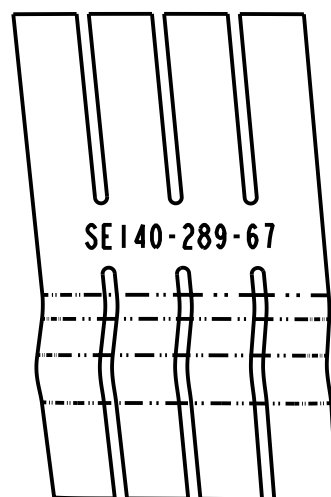
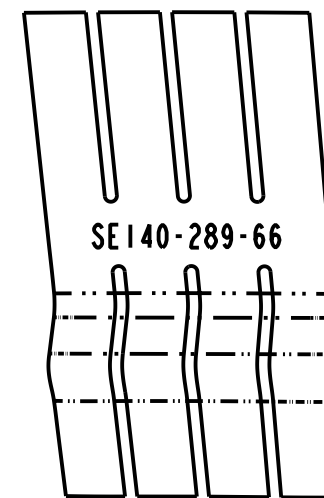
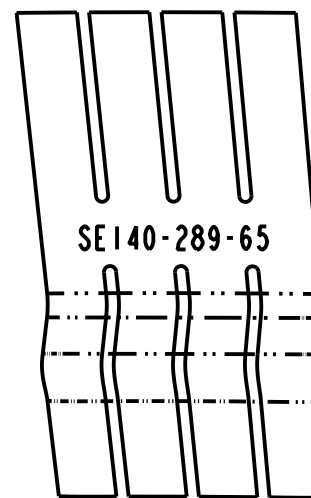
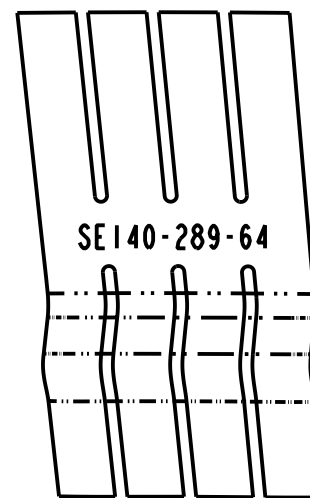
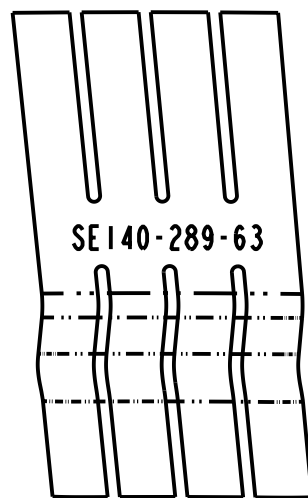
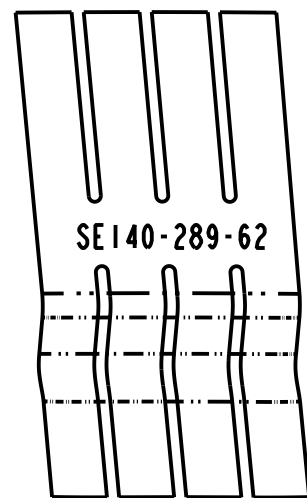
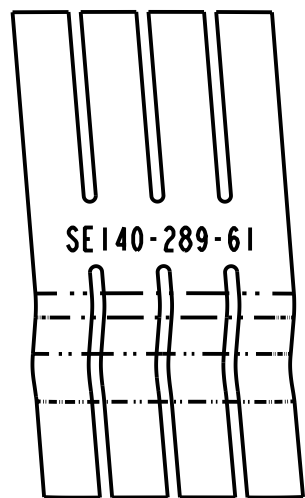



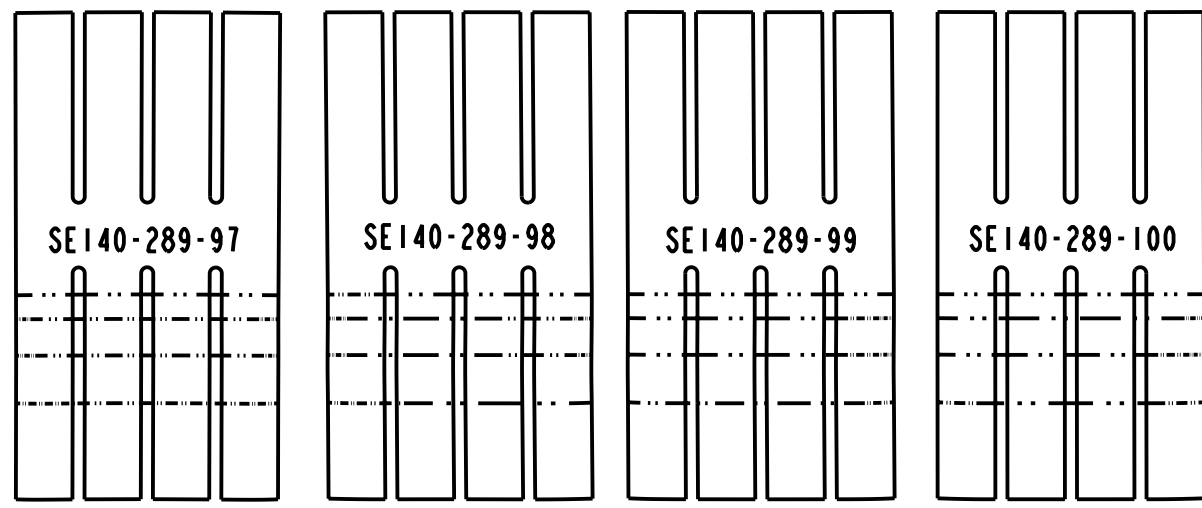
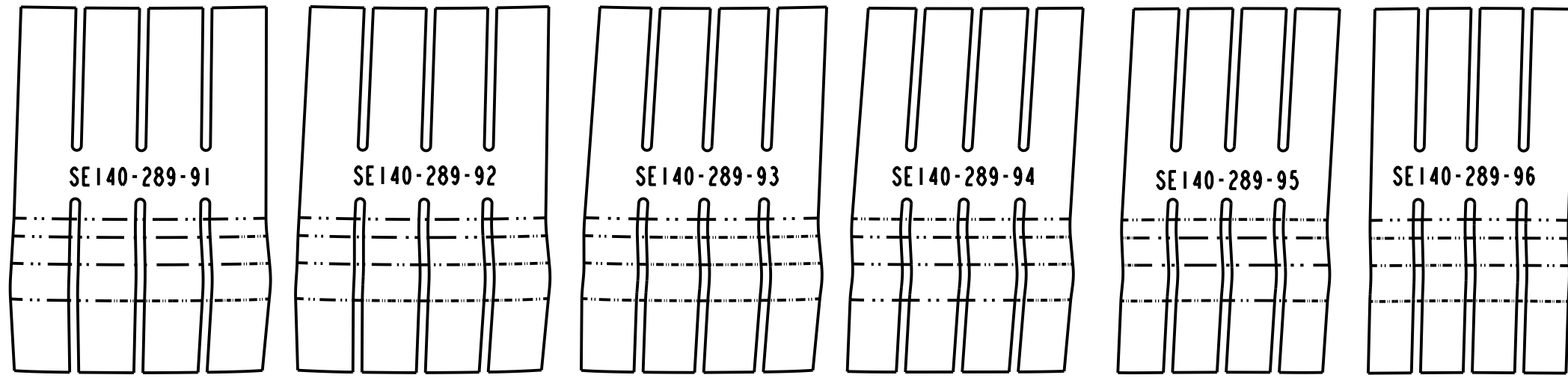
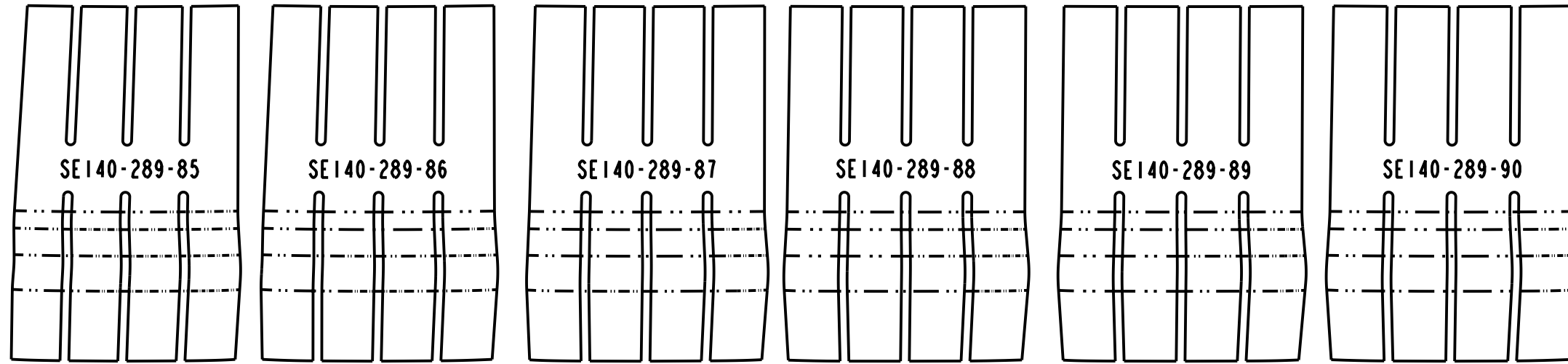

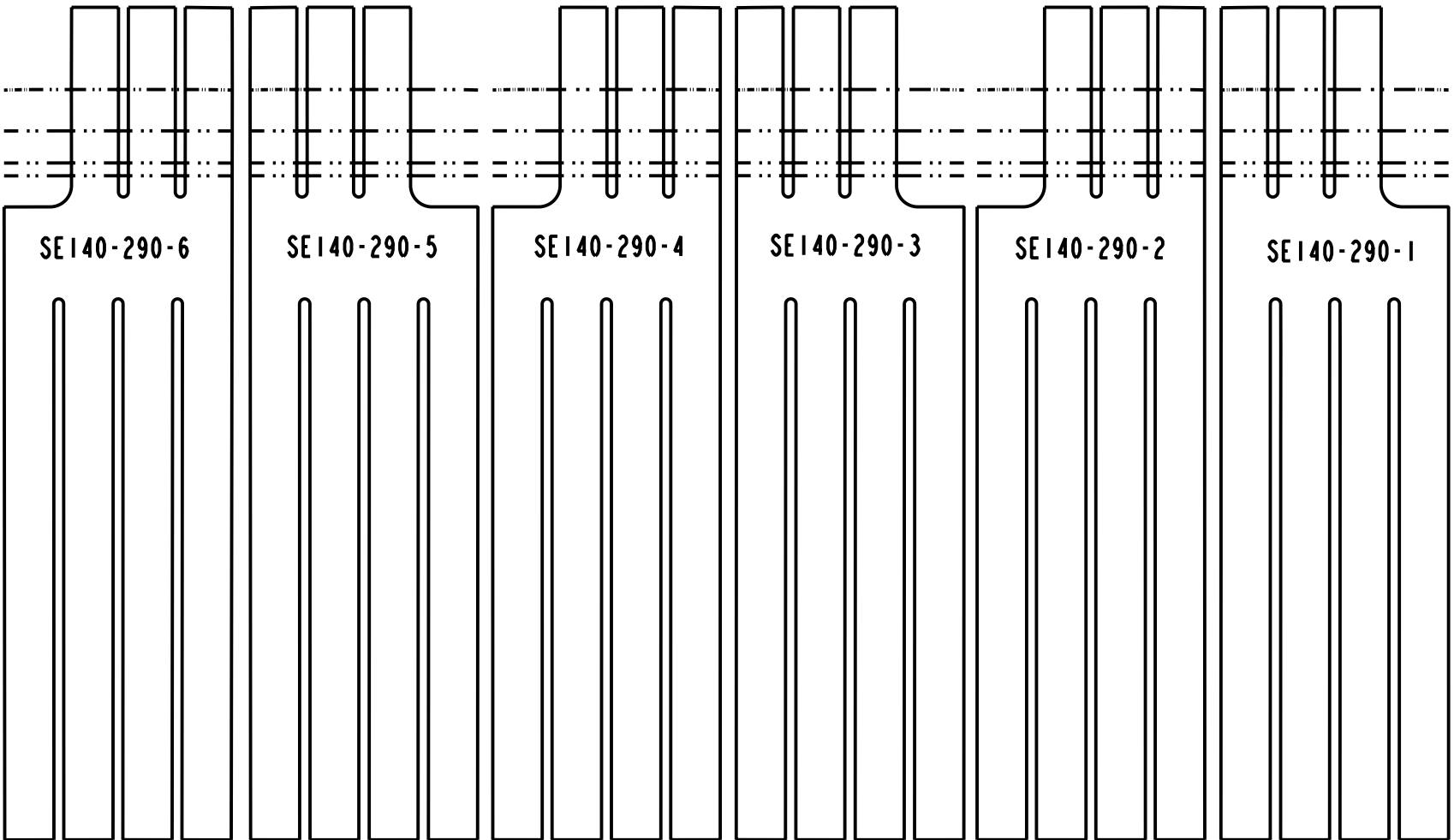



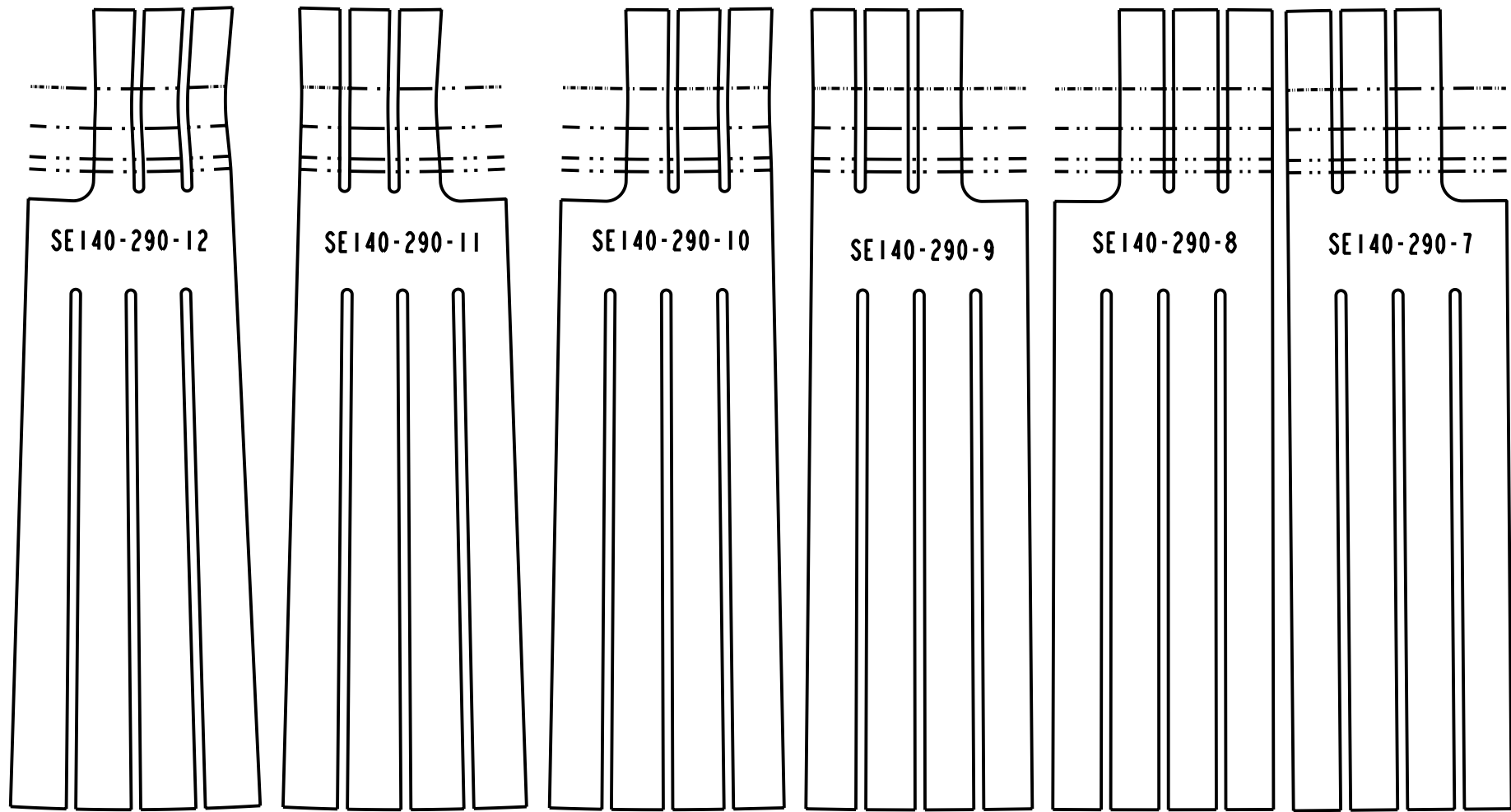

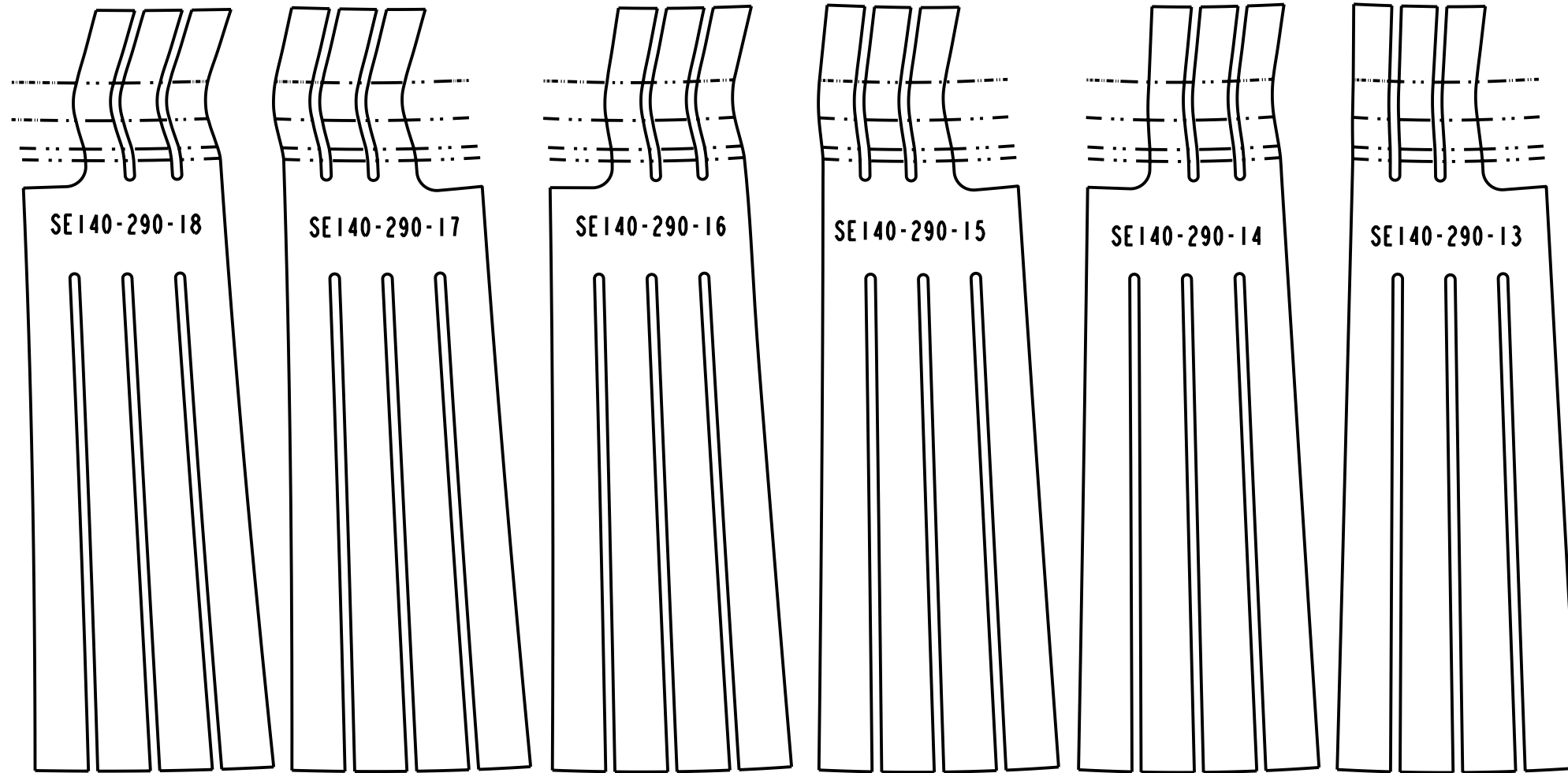

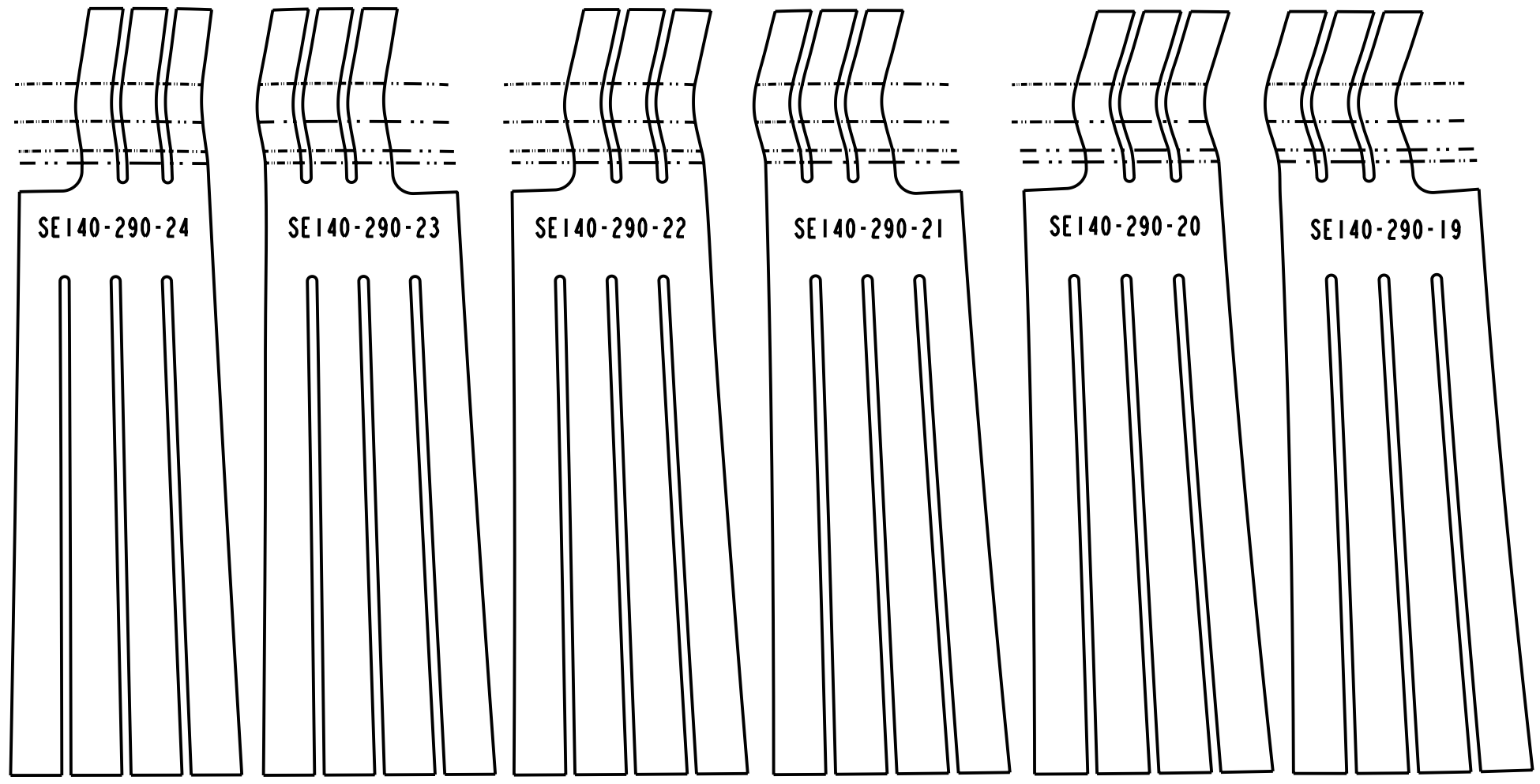

SE140-290-24

SE140-290-23

SE140-290-22

SE140-290-21

SE140-290-20

SE140-290-19

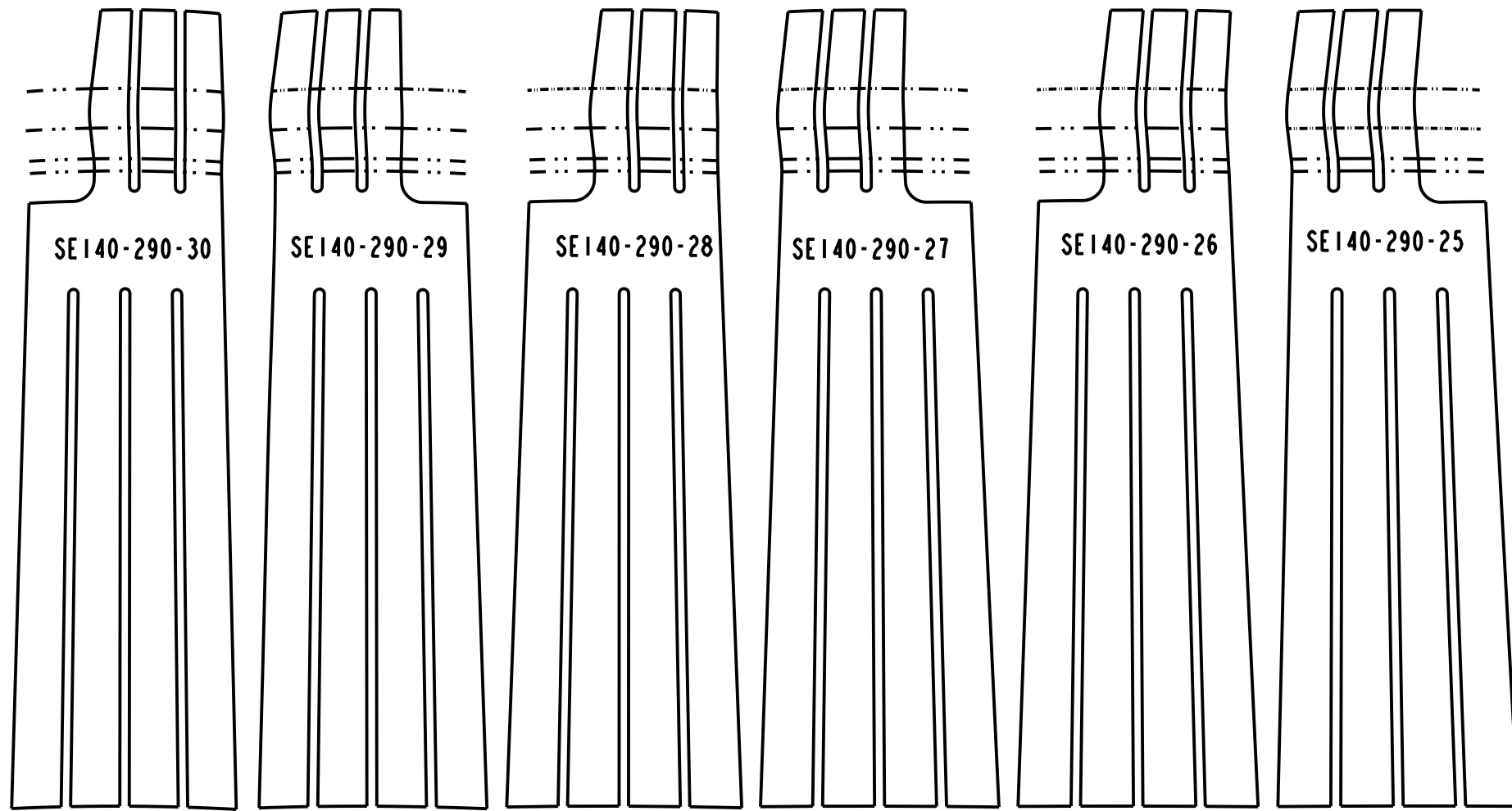

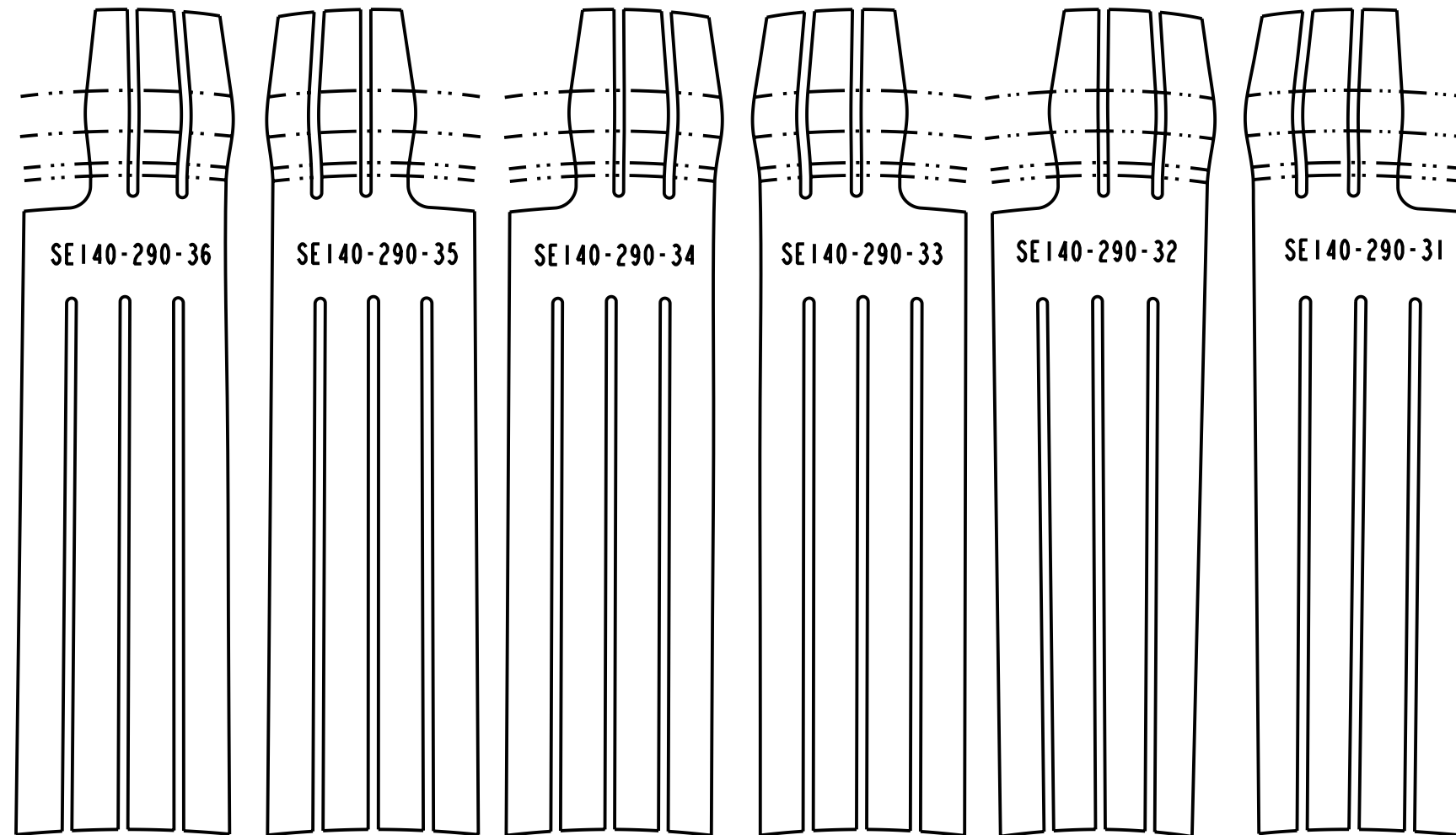

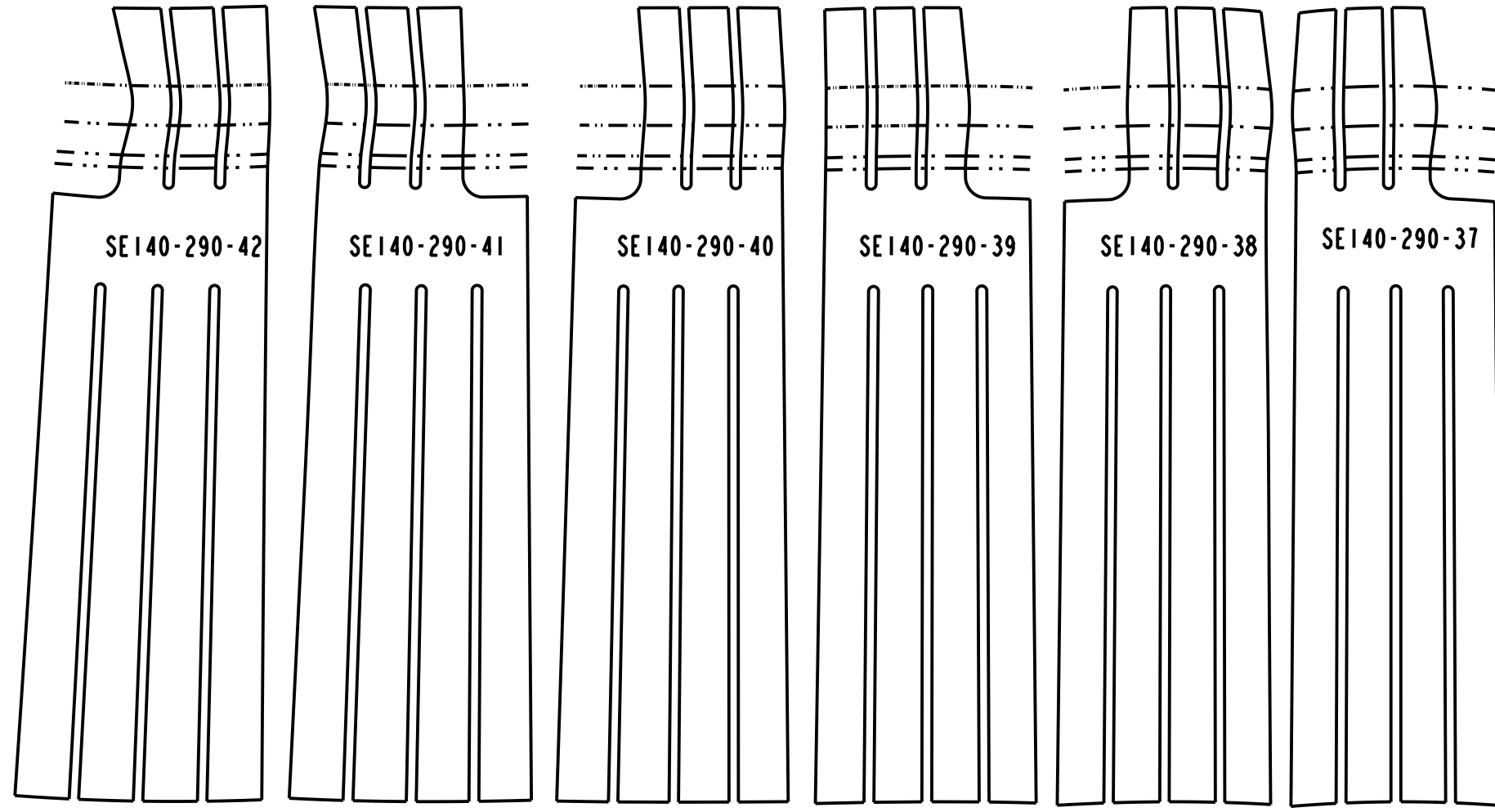

SE140-290-42

SE140-290-41

SE140-290-40

SE140-290-39

SE140-290-38

SE140-290-37

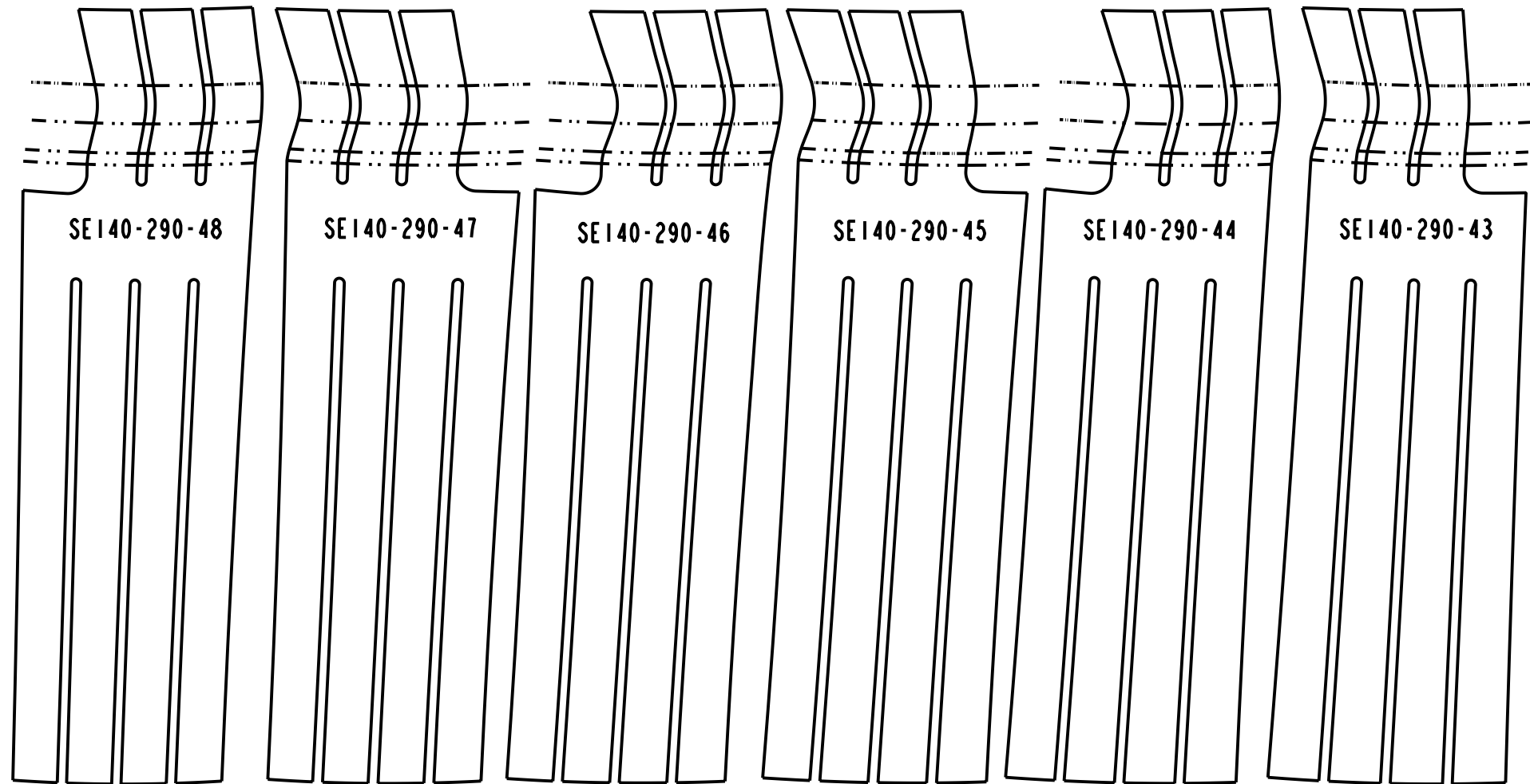

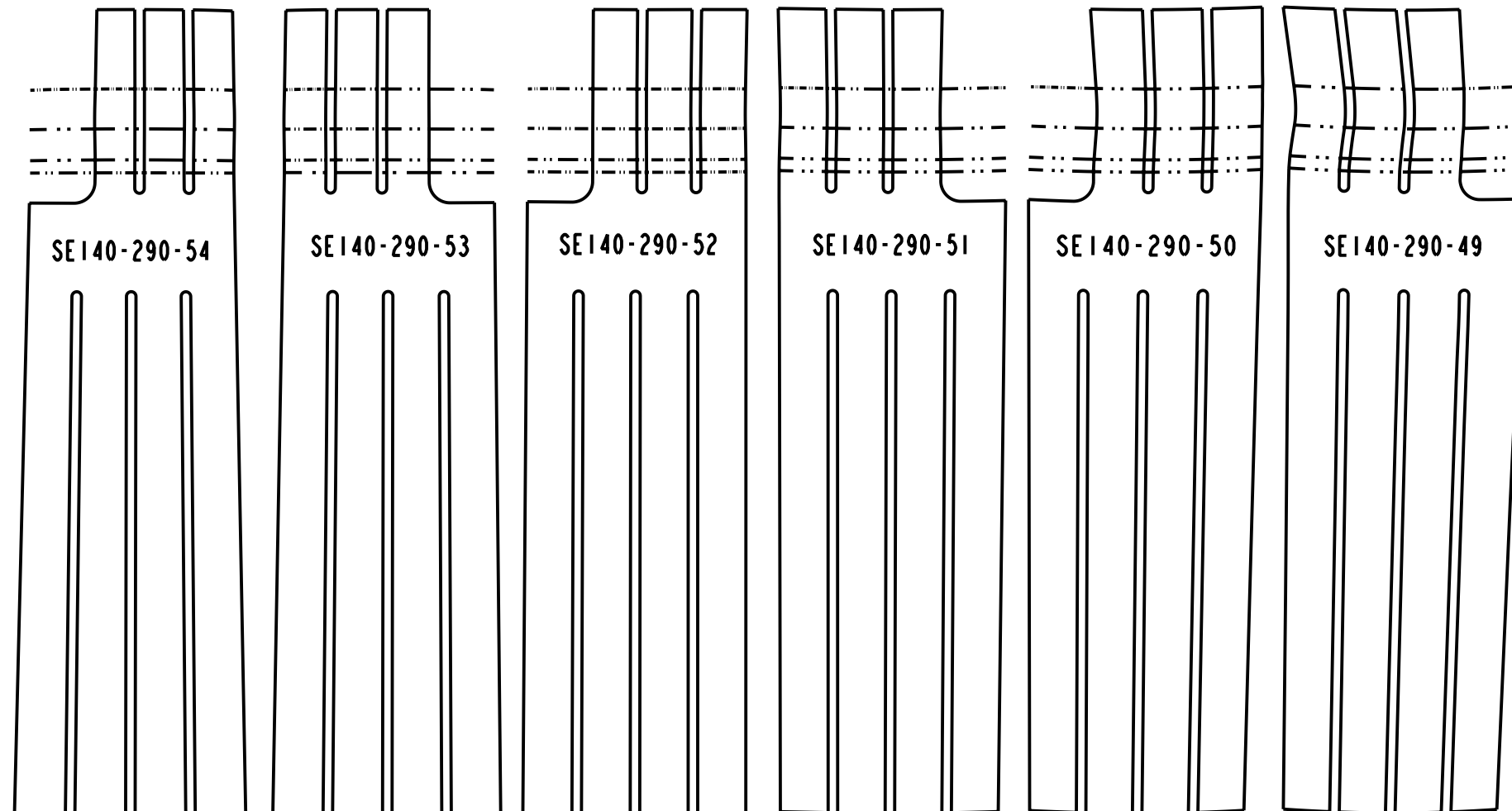



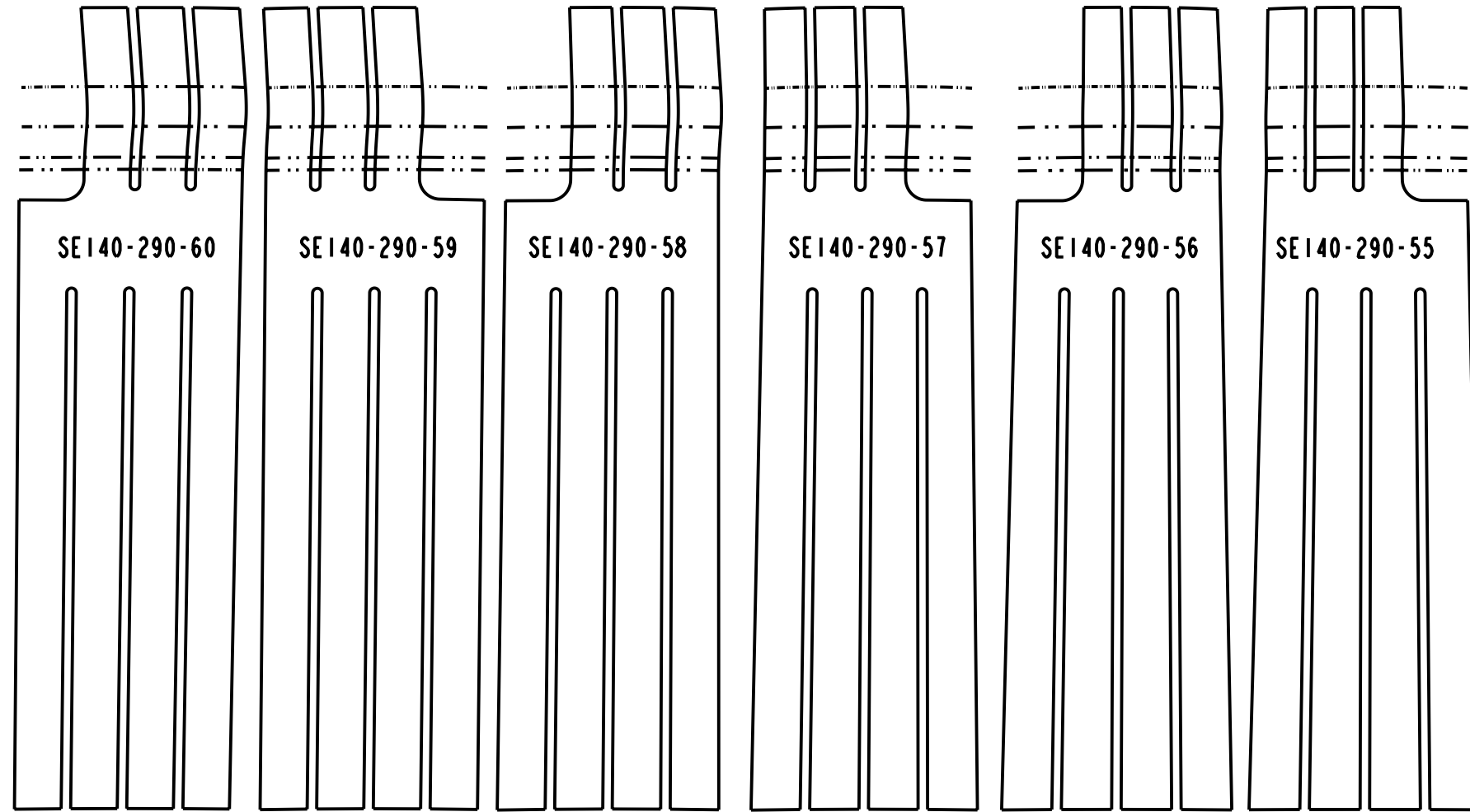

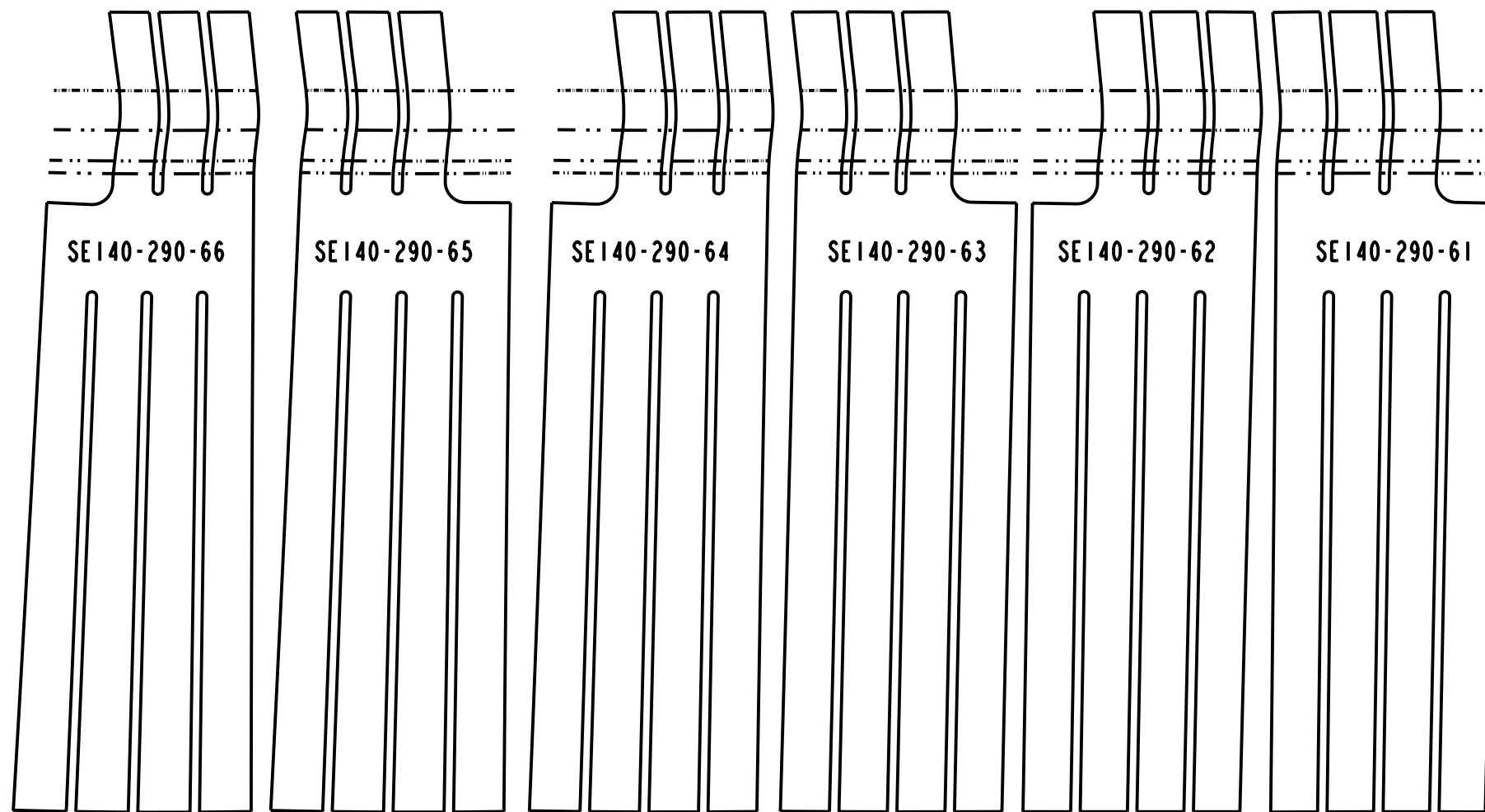

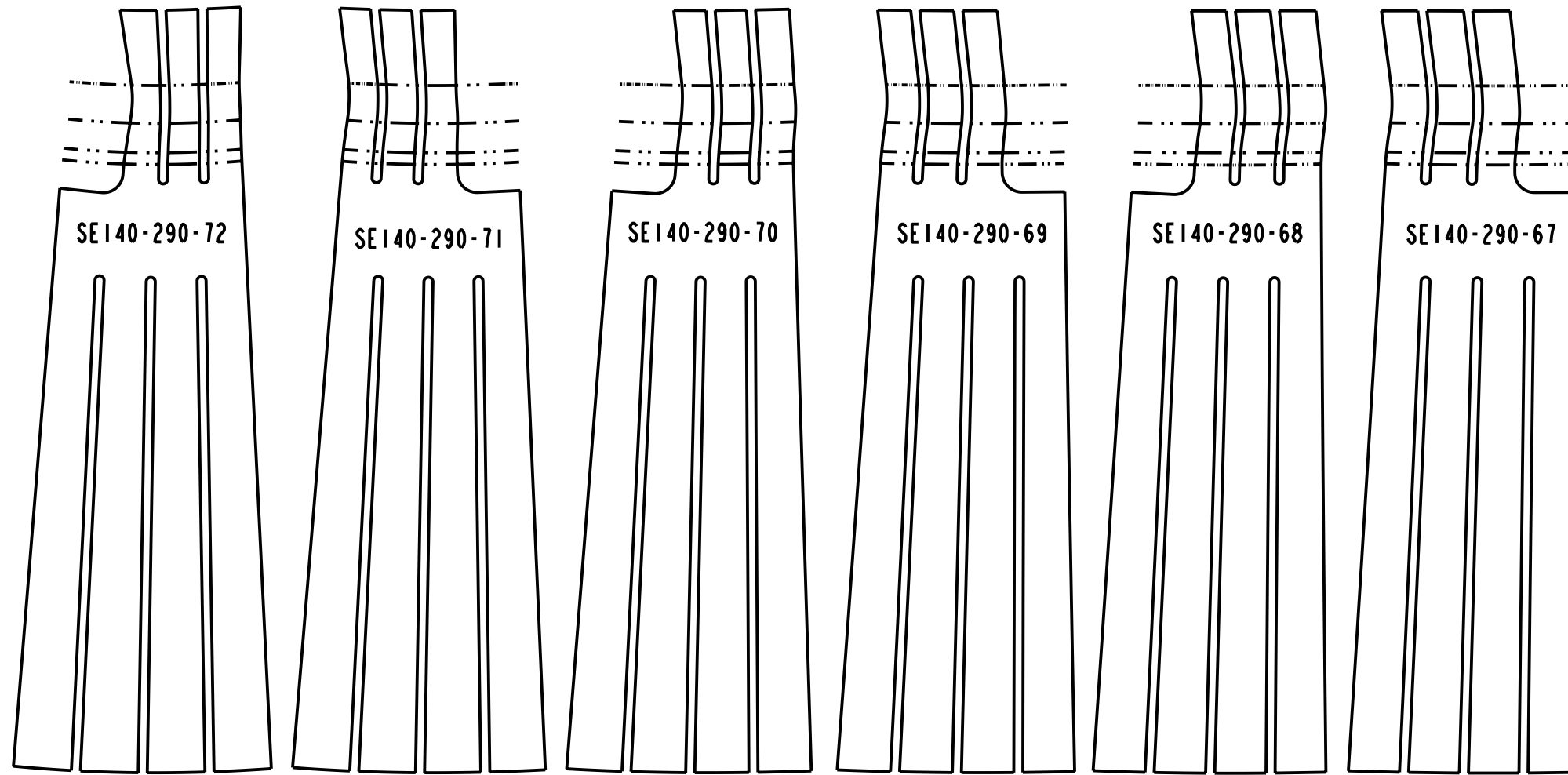

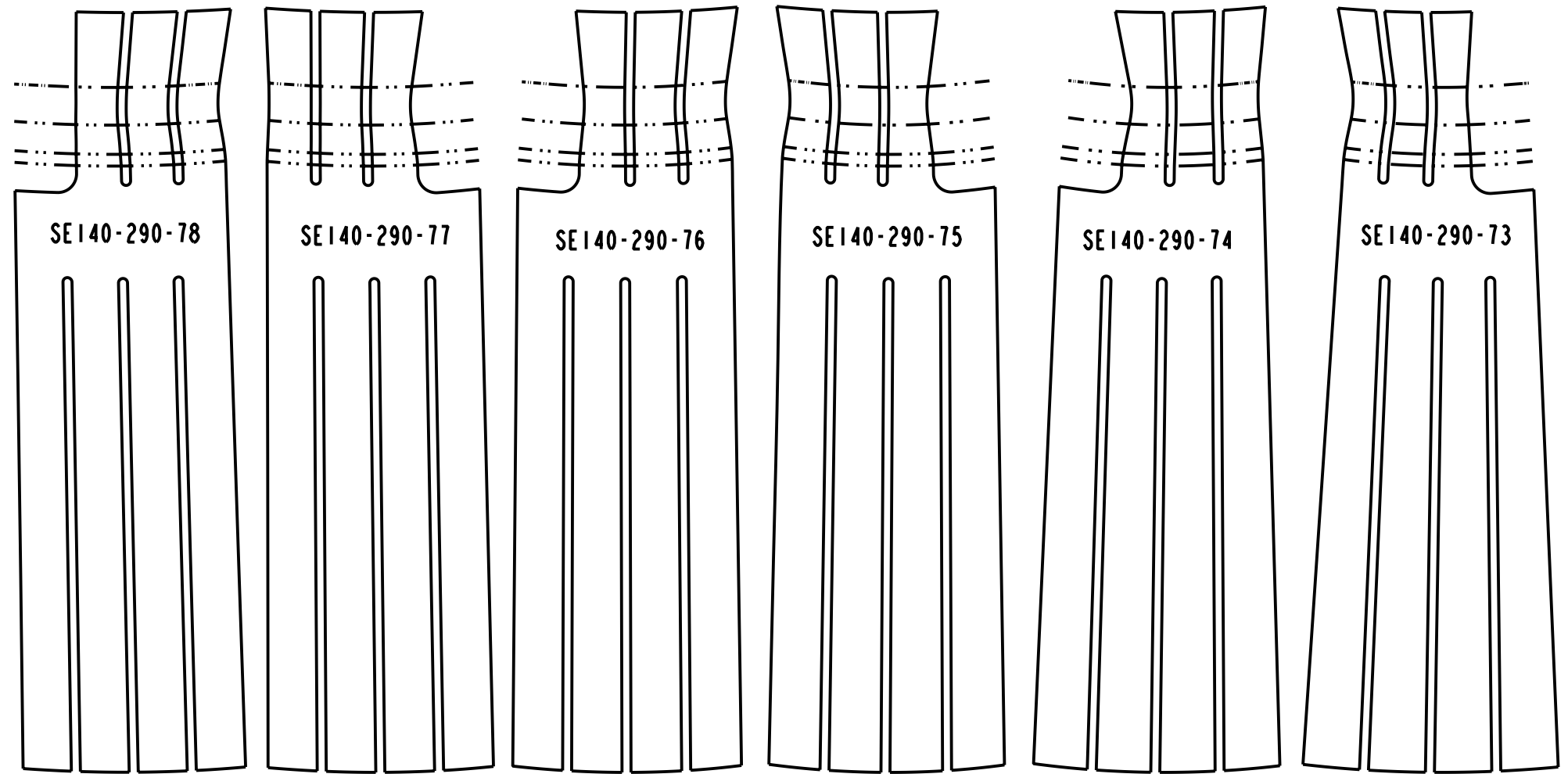

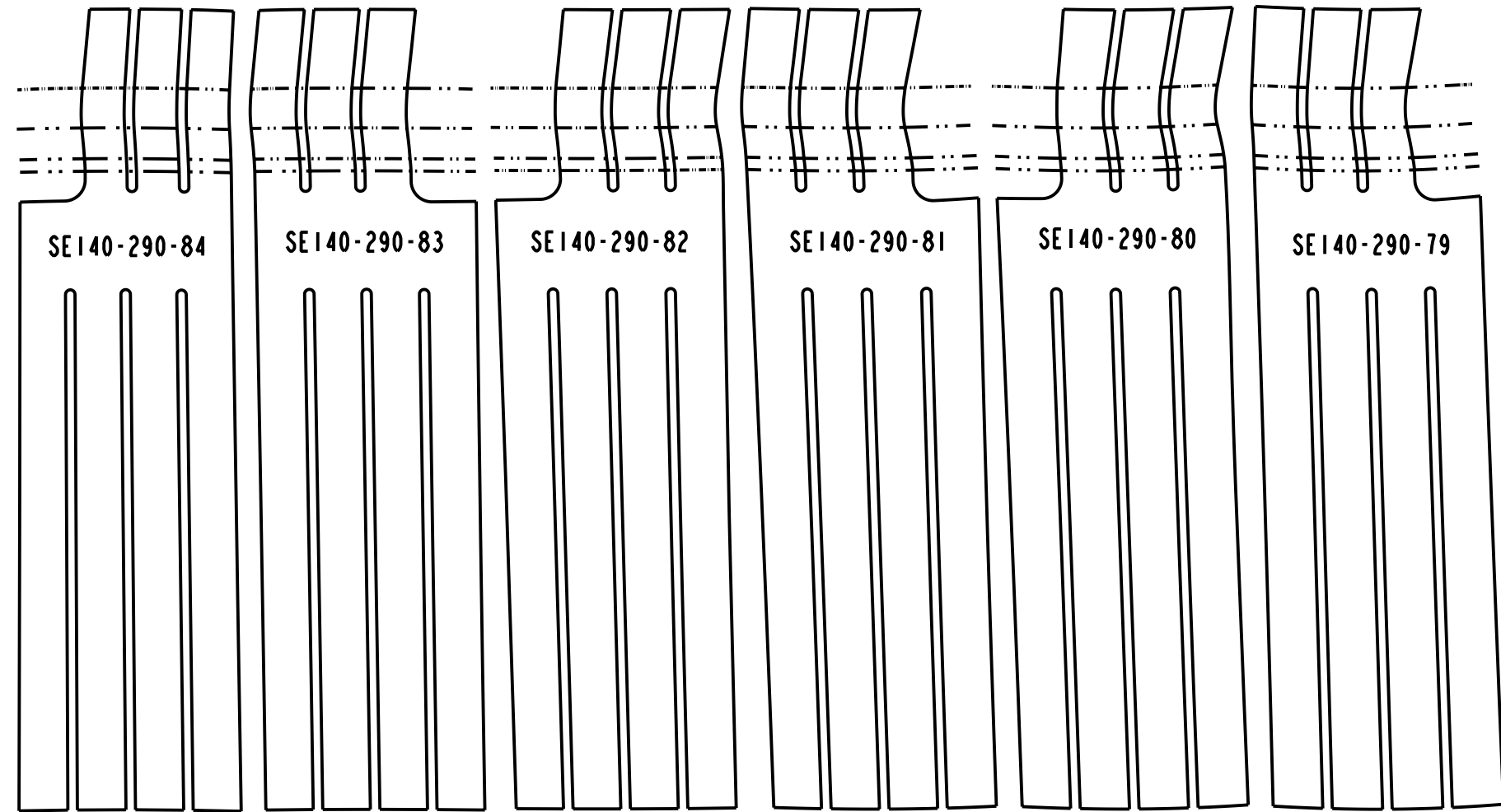

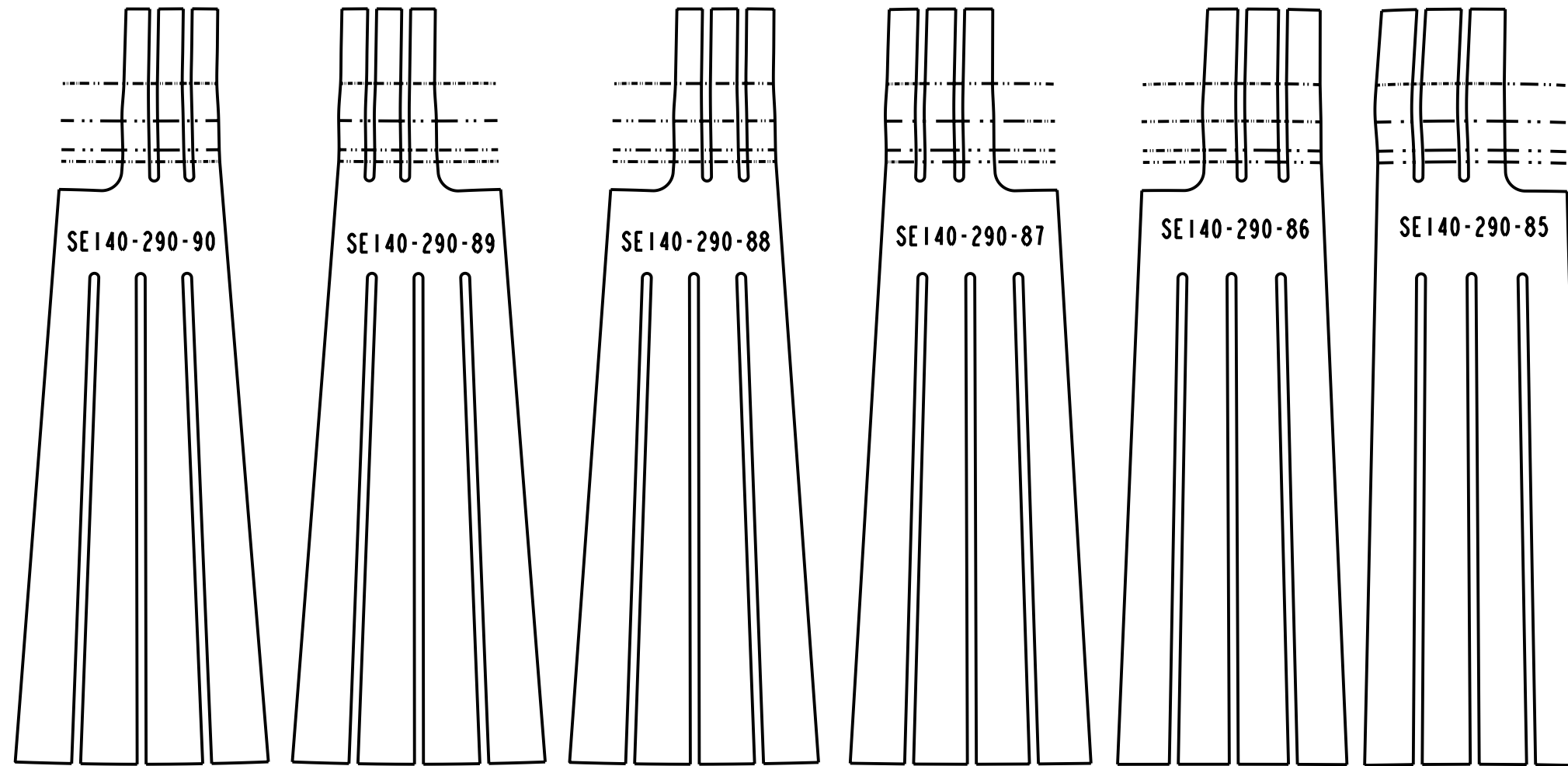

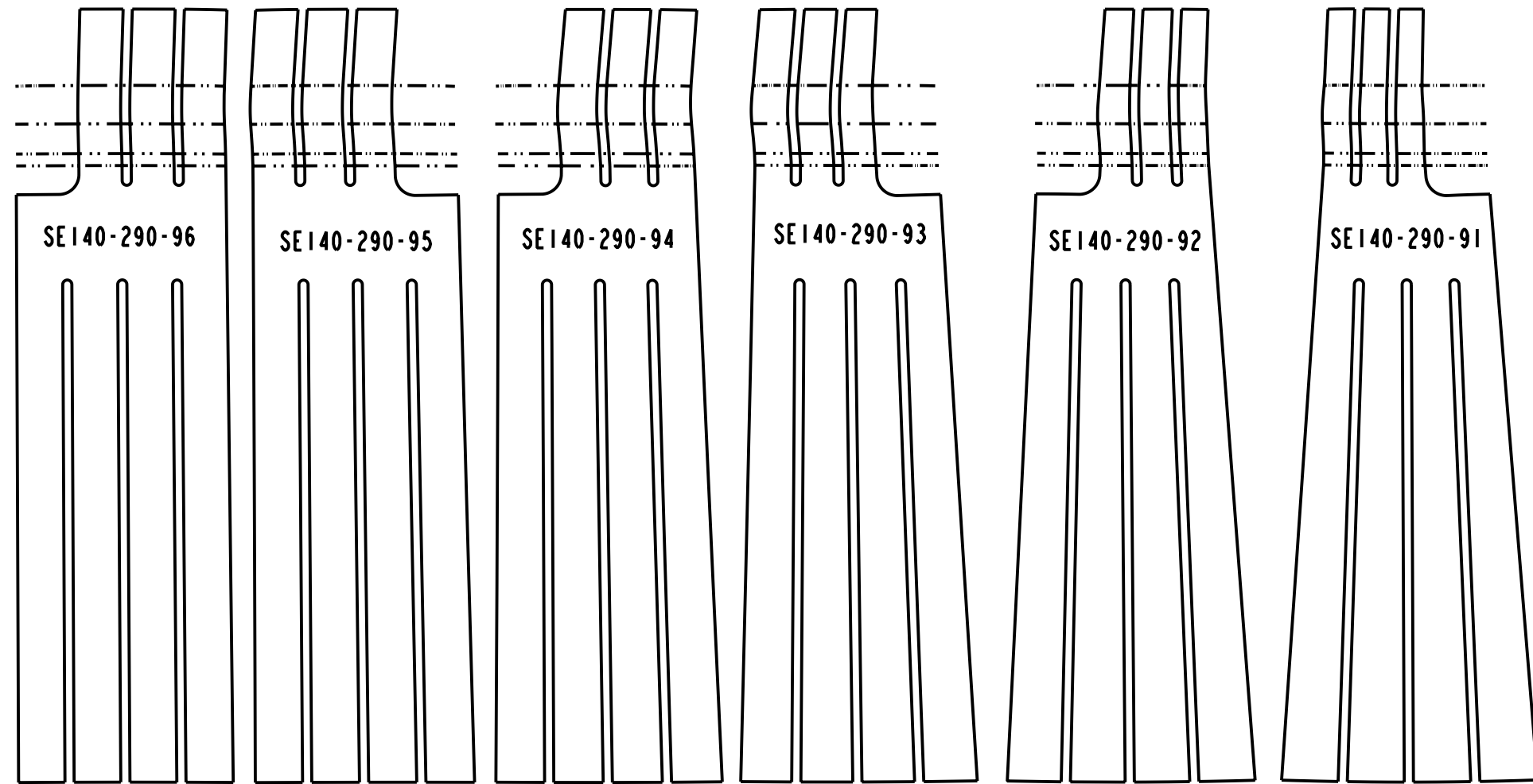

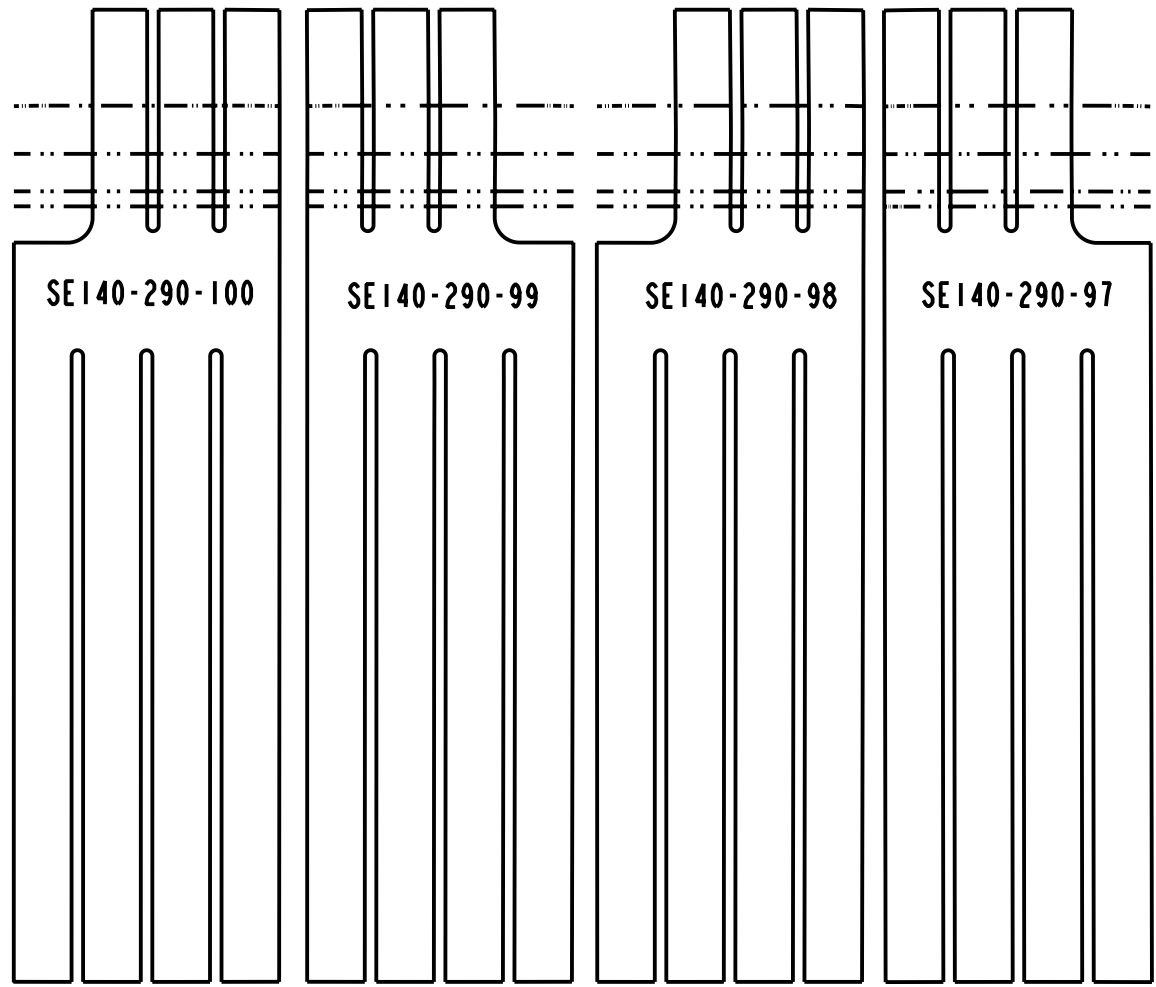



- NOTES:
1. INTERPRET DIMENSIONS AND TOLERANCES PER ANSI Y14.5M
  2. DIMENSIONS ARE IN INCHES
  3. DIMENSIONS APPLY AT ROOM TEMPERATURE. OPERATING TEMP 80 K
  4. GEOMETRY IS DEFINED IN PRO ENGINEER CAD MODELS/FILES
  5. DRAWING AND MODELS COMBINED DEFINE FINISHED MACHINED PART
  6. USE LOCTITE TO SECURE THREADED COMPONENTS

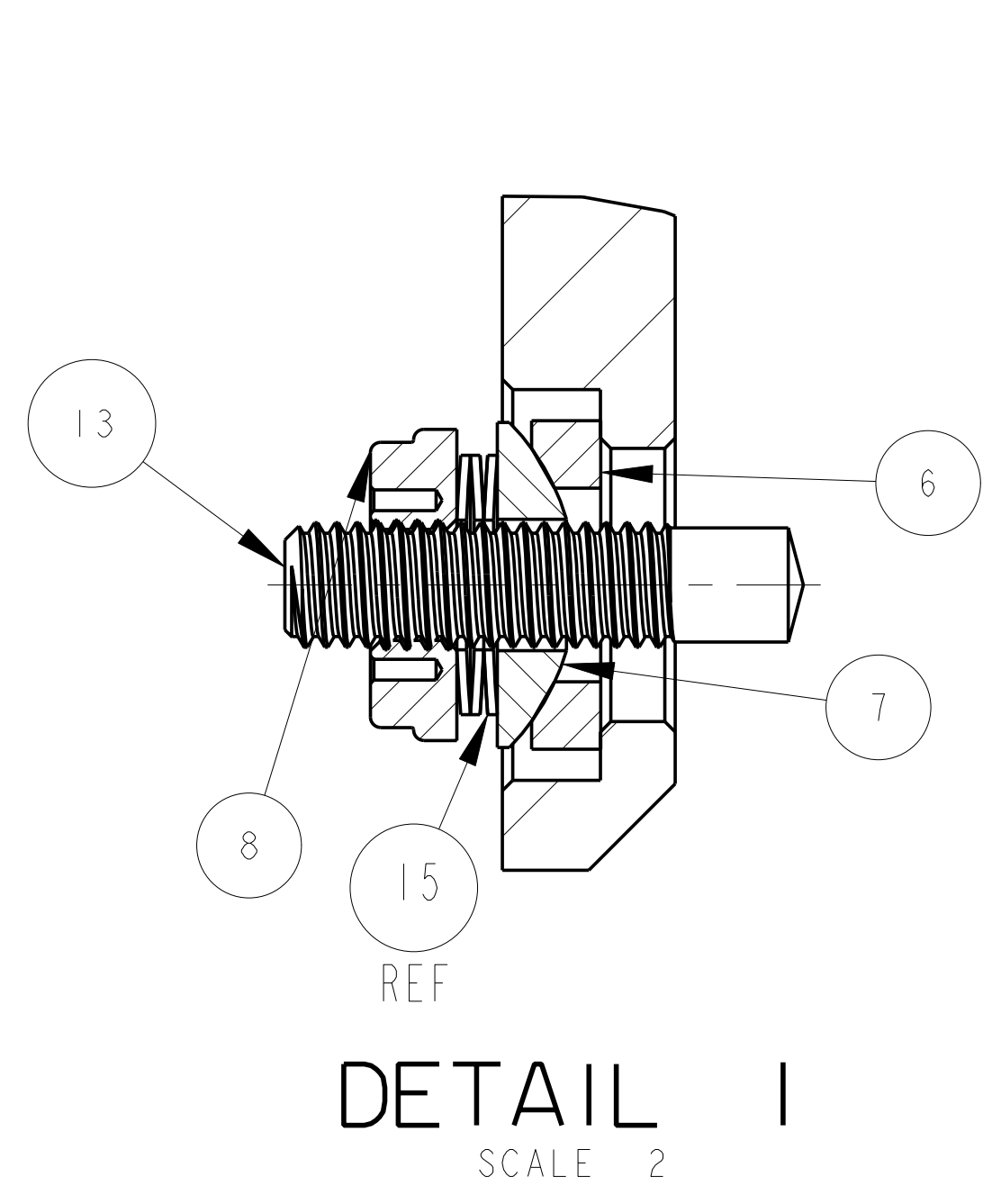
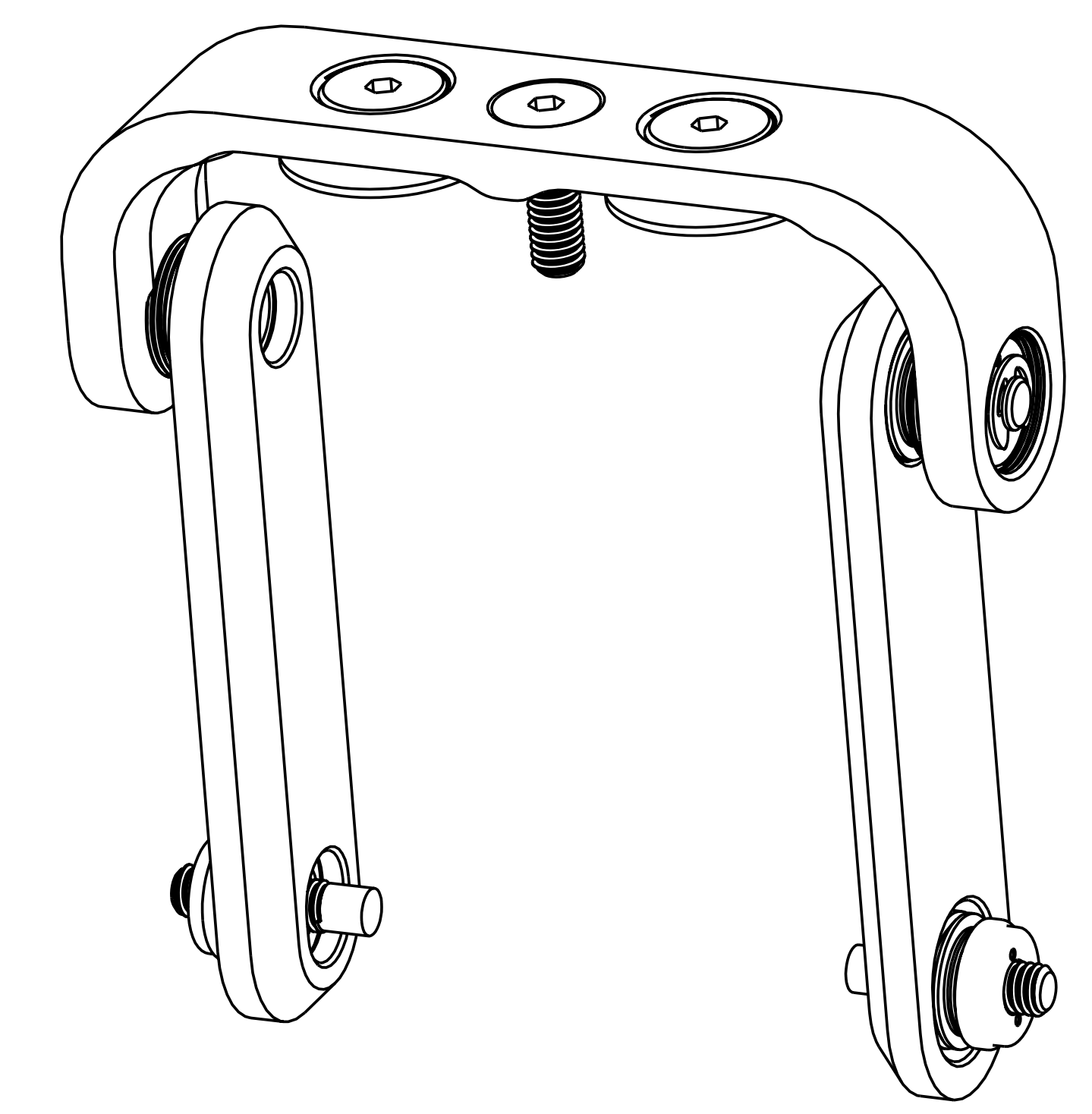
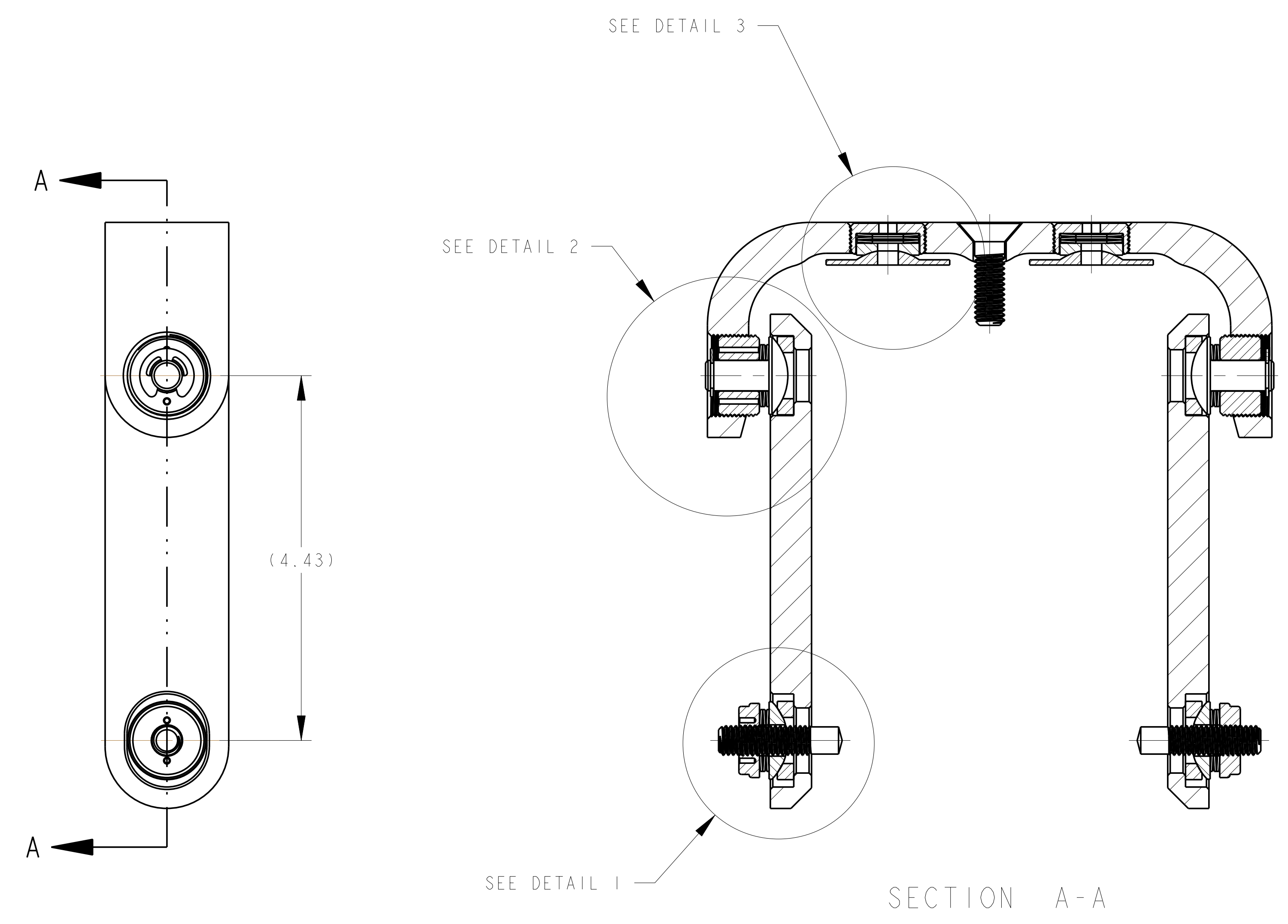
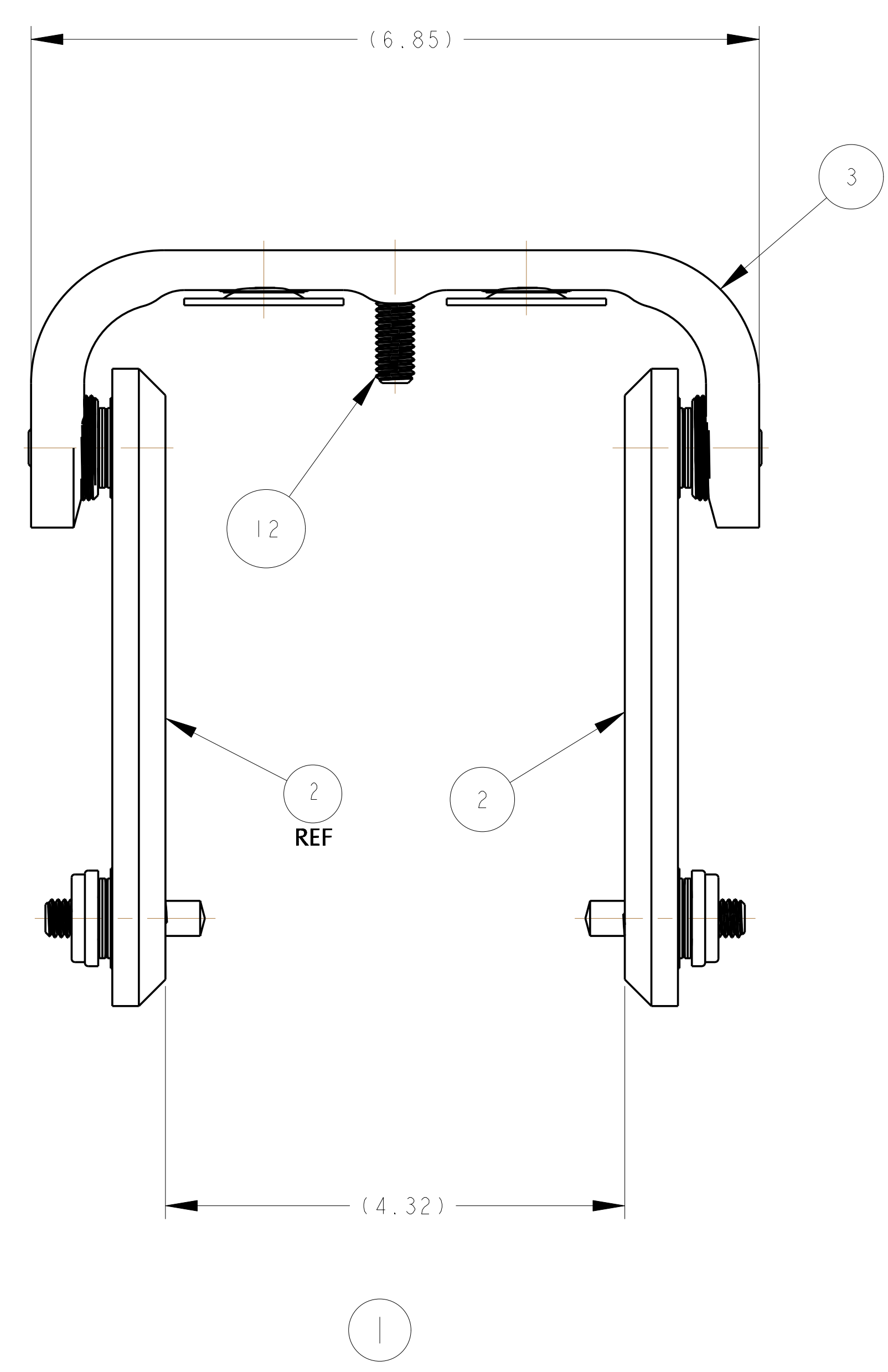
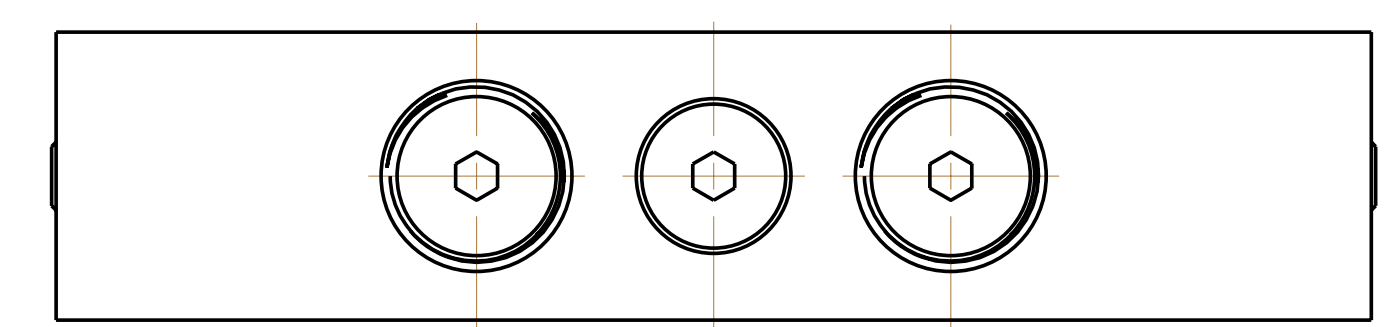

DETAIL 1  
SCALE 2

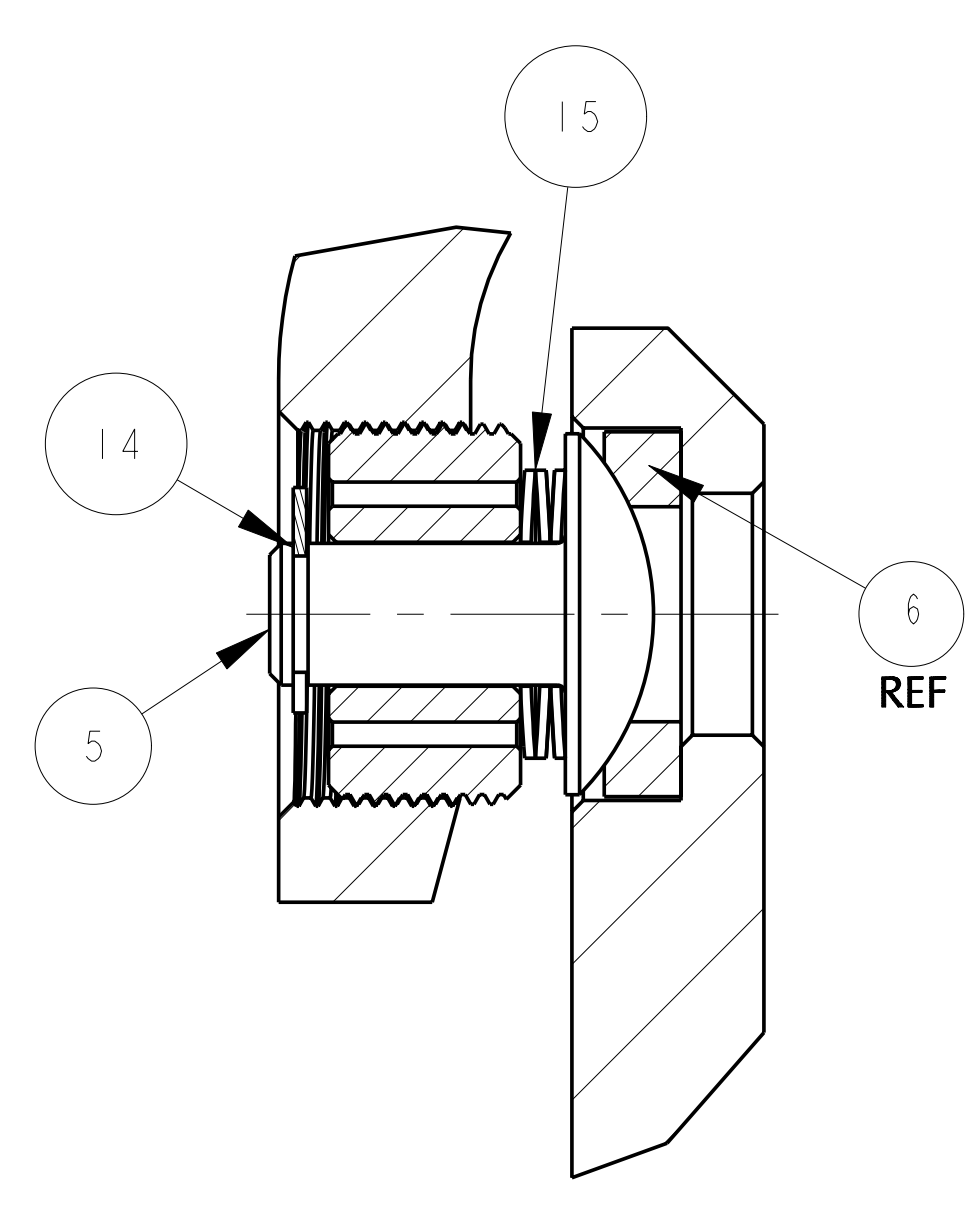

DETAIL 2  
SCALE 2

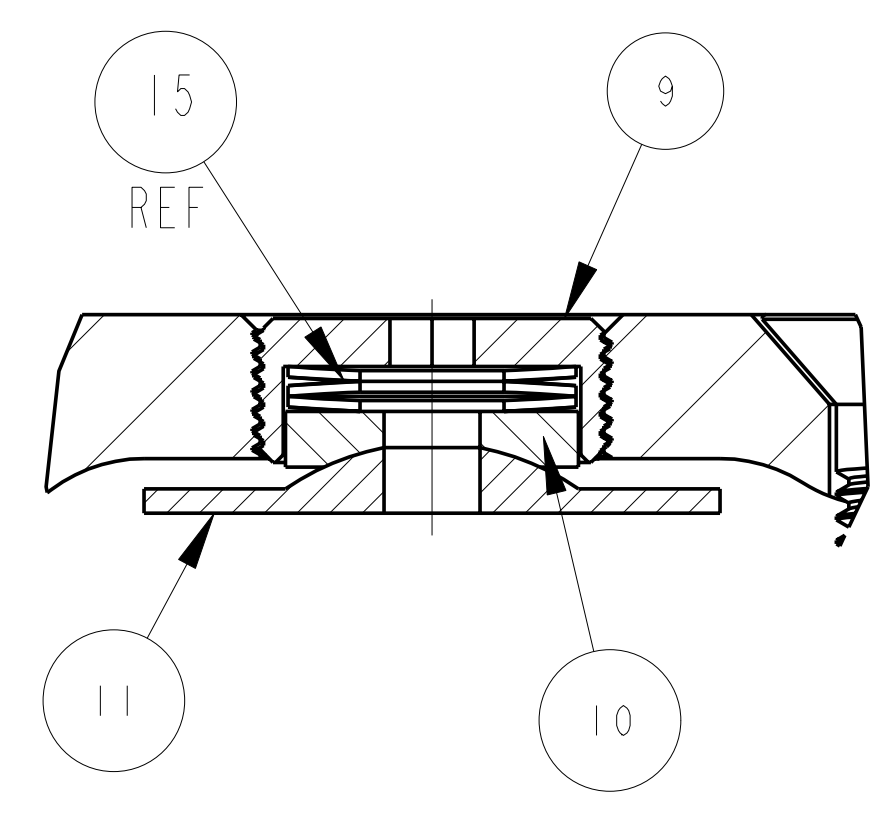

DETAIL 3  
SCALE 2

**RELEASED FOR FABRICATION / INSTALLATION**

CAGE CODE	PART OR IDENTIFYING NO	NOMENCLATURE OR DESCRIPTION	MATERIAL	SPECIFICATION	FIND NO
-	15	WASHER, BELLEVILLE, 3/4 OD, 3/8 ID	BERYLLIUM COPPER	K-7600 LBS/IN	15
-	14	E-RING, EXTERNAL	BERYLLIUM COPPER	MS16633-5037	14
2	SE1405-265P	STUD, WELD, 3/8-16 UNC-2A	316L SS	--	13
1	SE1405-264P	SCREW, 3/8-16 UNC-2A X 1 1/4	316L SS AG PLATED	--	12
2	SE1405-263P	WASHER, SPHERICAL, CONVEX	316L SS	--	11
2	SE1405-262P	PISTON, SPHERICAL, CONCAVE	A286 SUPERALLOY	--	10
2	SE1405-261P	SCREW, SET, 15/16-20 UNEF-2A X 3/8	316L SS AG PLATED	--	9
2	SE1405-260P	NUT, PIN DRIVE, 3/8-16 UNC-2B	316L SS AG PLATED	--	8
2	SE1405-259P	WASHER, SPHERICAL, TYPE C	A286 SUPERALLOY	DIN 6319 MODIFIED	7
4	SE1405-257P	WASHER, SPHERICAL, TYPE D	303 SS ANNEALED	DIN 6319	6
2	SE1405-256P	RIVET, SPECIAL BUTTON HEAD	A286 SUPERALLOY	--	5
2	SE1405-255P	SCREW, SET, 1-20 UNEF-2A X 1/2	316L SS AG PLATED	--	4
1	SE1405-254P	BAR, CLAMP, HORIZONTAL	316L SS	--	3
2	SE1405-251P	BAR, CLAMP, VERTICAL	316L SS	--	2
1	SE1405-250P	CLAMP ASSEMBLY, 40 TURN	--	--	1

← NEXT ASSEMBLY

PARTS LIST

NO REPRESENTATION OR WARRANTY, EXPRESSED OR IMPLIED, IS MADE AS TO THE ACCURACY, COMPLETENESS OR USEFULNESS OF THE INFORMATION OR STATEMENTS CONTAINED IN THESE DRAWINGS, OR THAT THE USE OR DISCLOSURE OF ANY INFORMATION, APPARATUS, METHOD OR PROCESS DISCLOSED IN THESE DRAWINGS MAY NOT INFRINGE PRIVATE RIGHTS OF OTHERS. NO LIABILITY IS ASSUMED WITH RESPECT TO THE USE OF, OR FOR DAMAGES RESULTING FROM THE USE OF, ANY INFORMATION, APPARATUS, METHOD OR PROCESS DISCLOSED IN THESE DRAWINGS. DRAWINGS MADE AVAILABLE FOR INFORMATION TO BIDDER ARE NOT TO BE USED FOR OTHER PURPOSES, AND ARE TO BE RETURNED UPON REQUEST OF THE FORWARDING CONTRACTOR.

**P** THIS DRAWING PRODUCED ON PRO-ENGINEER

REV	DESCRIPTION	BY	DATE	CHK	DEPT	DATE	PE	REQ	DATE	ORNL	DOE	DATE

SCALE	1	DES	PAUL MILLER	4-12-04
TOLERANCES UNLESS OTHERWISE SPECIFIED		DRW	PAUL MILLER	4-13-04
FRACTIONS		CHK		
XX DECIMALS	± .01	SECT		
XXX DECIMALS	± .005	DEPT		
ANGLES	± 0'15"	PE		
FINISH	AS UNLESS OTHERWISE SPECIFIED	CR		
		PJ		
		RD		
		PPPL DRFT		

<b>UT-BATTELLE</b>					
NATIONAL COMPACT STELLARATOR EXPERIMENT					
CLAMP ASSEMBLY, 40 TURN					
VERSION NO.	PLANT	BLDG	FL	SHT OF	TYPE
1	X-10	5700	3	1	S
RELEASE LEVEL	WIP		SE1405-250P		
DRAWING APPROVALS	DATE	REV	0		

H G F E D C B A

NOTES:

1. INTERPRET DIMENSIONS AND TOLERANCES PER ANSI Y14.5M
2. DIMENSIONS ARE IN INCHES
3. DIMENSIONS APPLY AT ROOM TEMPERATURE. OPERATING TEMP 80 K
4. GEOMETRY IS DEFINED IN PRO ENGINEER CAD MODELS/FILES
5. DRAWING AND MODELS COMBINED DEFINE FINISHED MACHINED PART

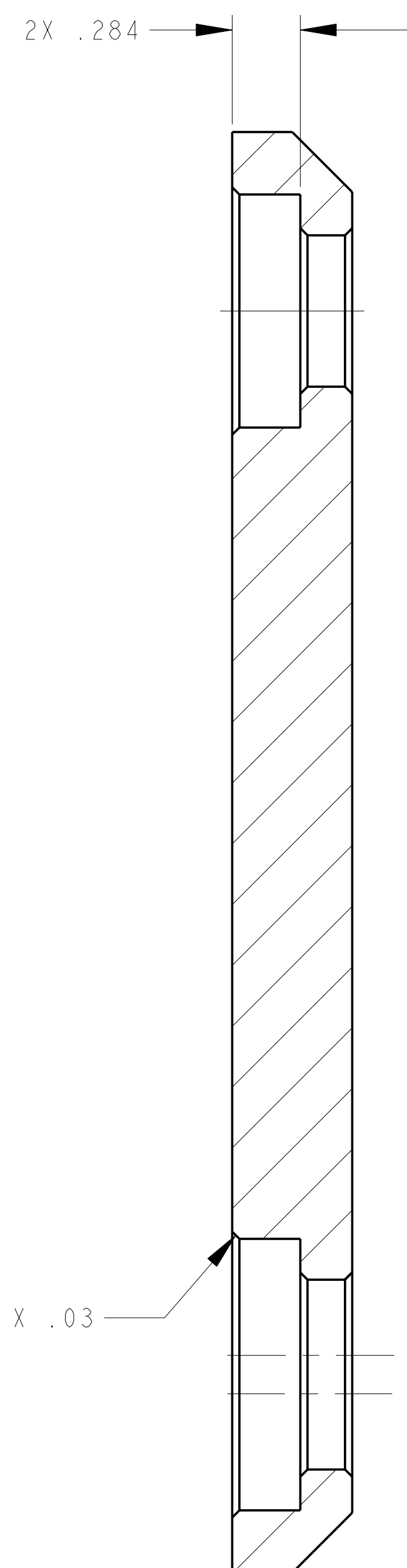
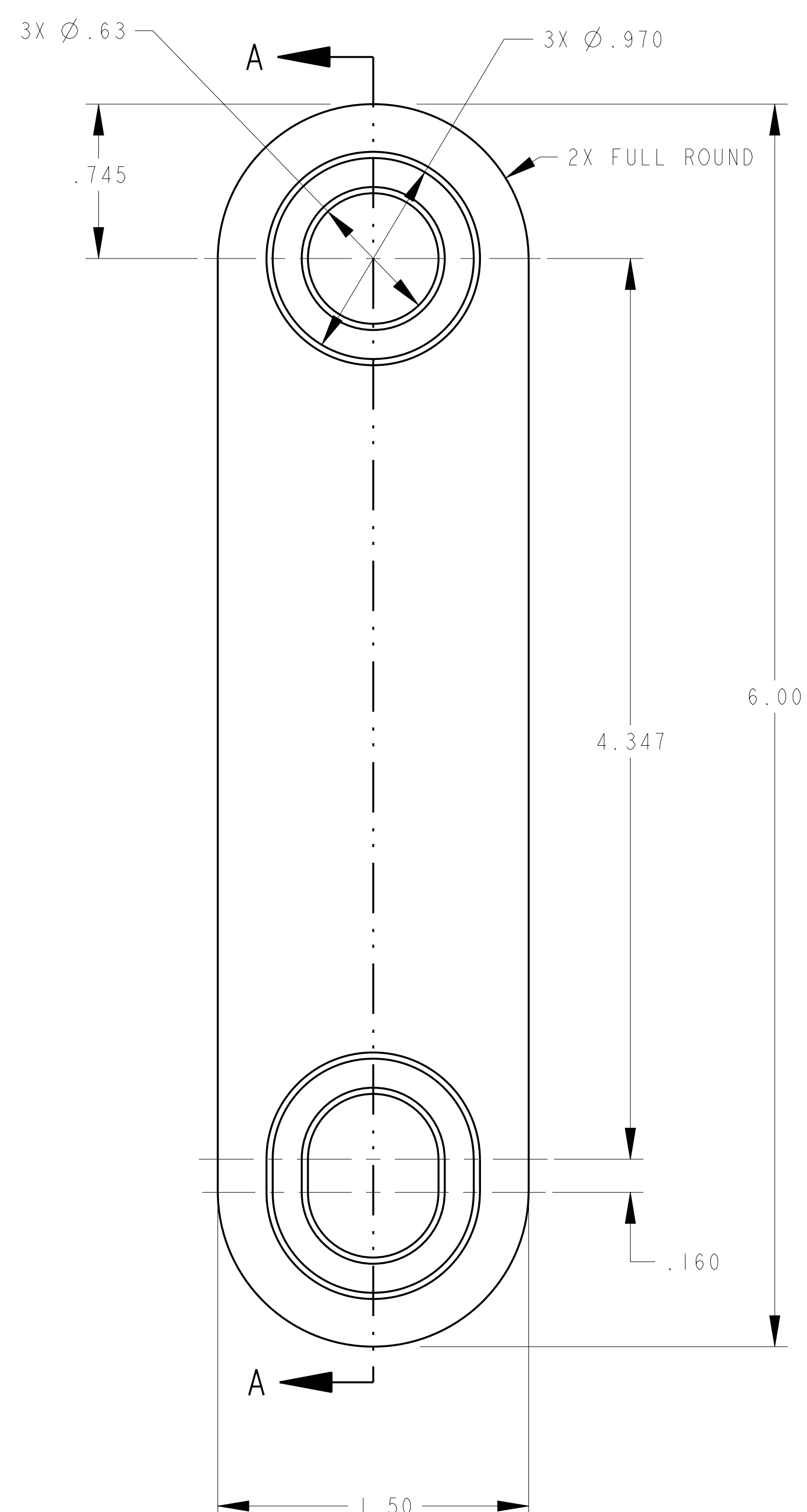
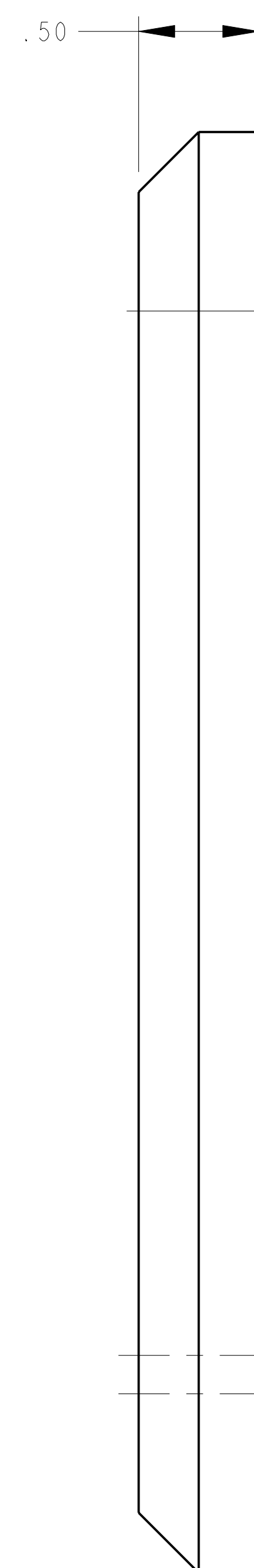
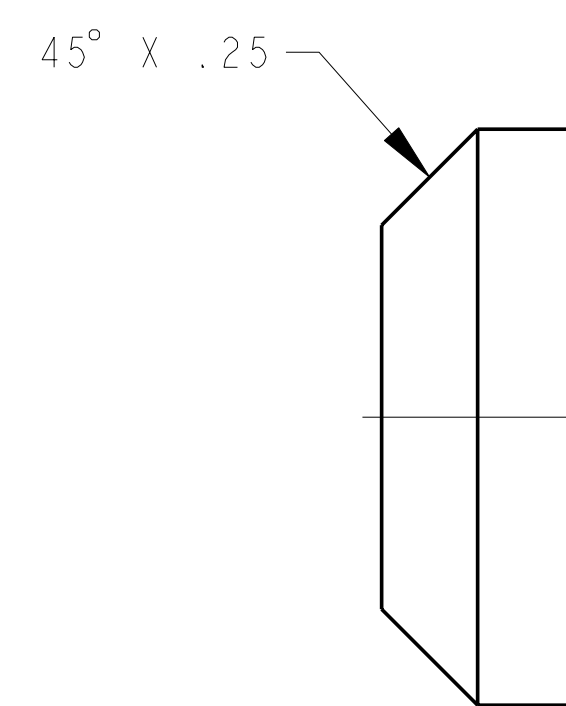

SECTION A-A

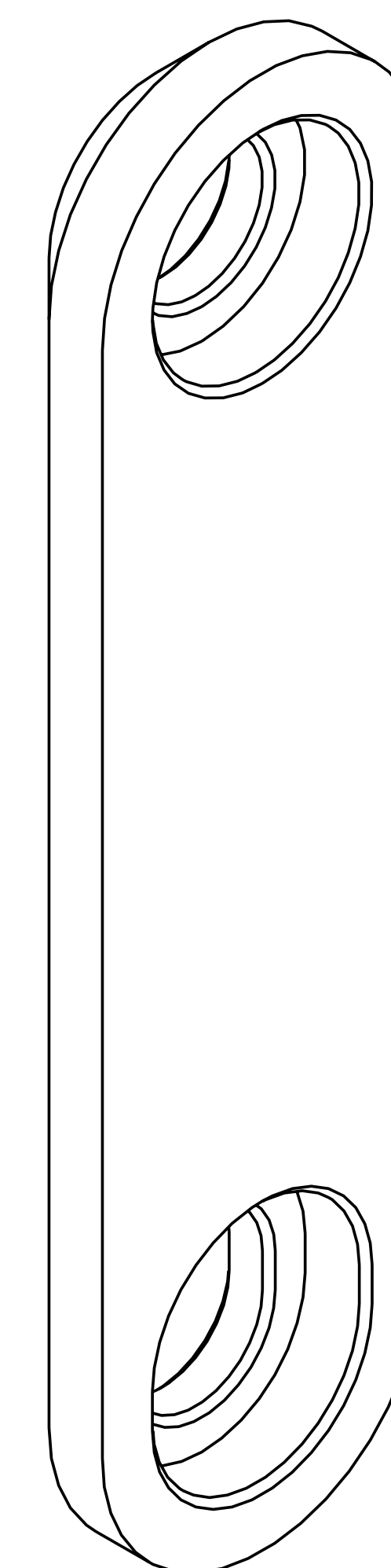

**RELEASED FOR FABRICATION / INSTALLATION**

AR	SEI405-251P	BAR, CLAMP, VERTICAL	316L SS	--	I
CAGE CODE	PART OR IDENTIFYING NO	NOMENCLATURE OR DESCRIPTION	MATERIAL	SPECIFICATION	FIND NO
SEI405-250					
		← NEXT ASSEMBLY	PARTS LIST		

NO REPRESENTATION OR WARRANTY, EXPRESSED OR IMPLIED, IS MADE AS TO THE ACCURACY, COMPLETENESS OR USEFULNESS OF THE INFORMATION OR STATEMENTS CONTAINED IN THESE DRAWINGS, OR THAT THE USE OR DISCLOSURE OF ANY INFORMATION, APPARATUS, METHOD OR PROCESS DISCLOSED IN THESE DRAWINGS MAY NOT INFRINGE PRIVATE RIGHTS OF OTHERS. NO LIABILITY IS ASSUMED WITH RESPECT TO THE USE OF, OR FOR DAMAGES RESULTING FROM THE USE OF, ANY INFORMATION, APPARATUS, METHOD OR PROCESS DISCLOSED IN THESE DRAWINGS. DRAWINGS MADE AVAILABLE FOR INFORMATION TO BIDDERS ARE NOT TO BE USED FOR OTHER PURPOSES, AND ARE TO BE RETURNED UPON REQUEST OF THE FORWARDING CONTRACTOR.	<b>P</b> THIS DRAWING PRODUCED ON PRO-ENGINEER	SCALE 2	DES PAUL MILLER 4-12-04	Oak Ridge National Laboratory managed for the DEPARTMENT OF ENERGY under U.S. GOVERNMENT contract DE-AC05-00OR22725 UT-BATTELLE, LLC, Oak Ridge, Tennessee PROJECT NAME <b>NATIONAL COMPACT STELLARATOR EXPERIMENT</b> BAR, CLAMP, VERTICAL
		DRW PAUL MILLER 4-13-04	UT-BATTELLE	
	CHK : :	DEPT : :	PPPL DRFT : :	
	SECT : :	PLANT : X-10	VERSION NO. 4	
	DEPT : :	BLDG 5700	FL 3	
	PE : :	SHT 1	OF 1	
	CR : :	TYPE S	CLASS U	
	PJ : :	RELEASE LEVEL	REV 0	
	REO : :	Fabrication		
	FINISH : :25 UNLESS OTHERWISE SPECIFIED	DATE		

REV	DESCRIPTION	BY	DATE	CHK	DEPT	DATE	PE	REG	DATE	ORNL	DOE	DATE
	REVISION OR ISSUE PURPOSE											

SEI405-251P

- NOTES:  
1. INTERPRET DIMENSIONS AND TOLERANCES PER ANSI Y14.5M  
2. DIMENSIONS ARE IN INCHES  
3. DIMENSIONS APPLY AT ROOM TEMPERATURE. OPERATING TEMP 80 K  
4. GEOMETRY IS DEFINED IN PRO ENGINEER CAD MODELS/FILES  
5. DRAWING AND MODELS COMBINED DEFINE FINISHED MACHINED PART

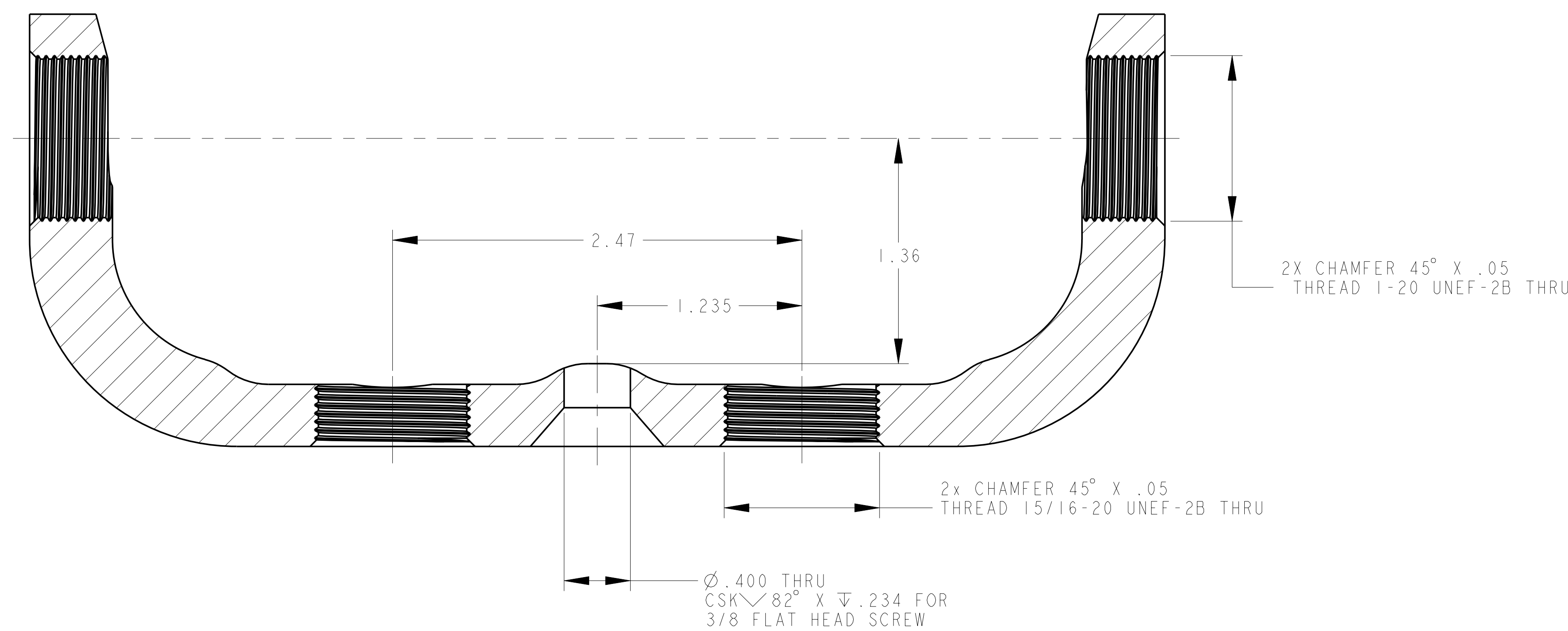
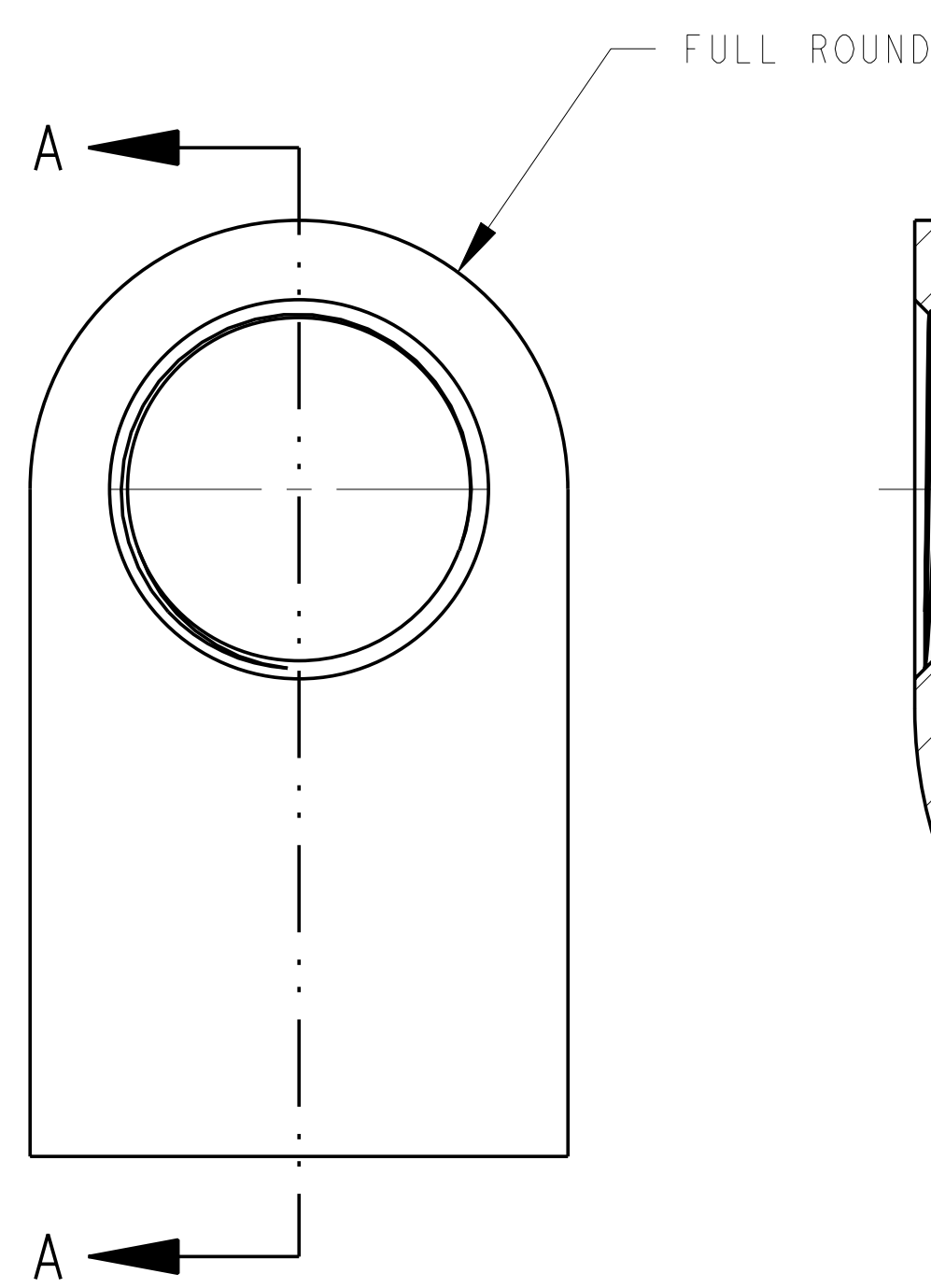
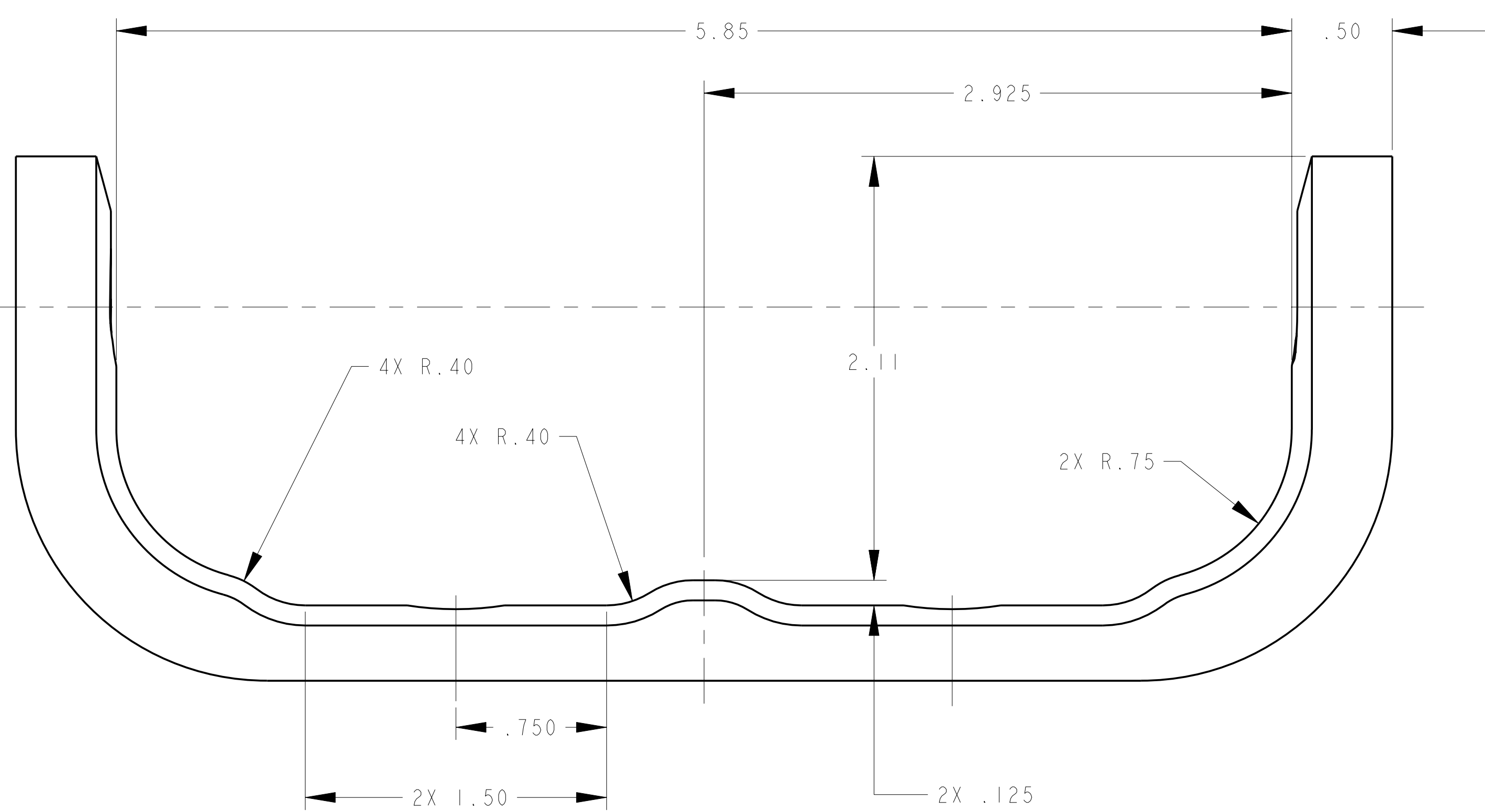
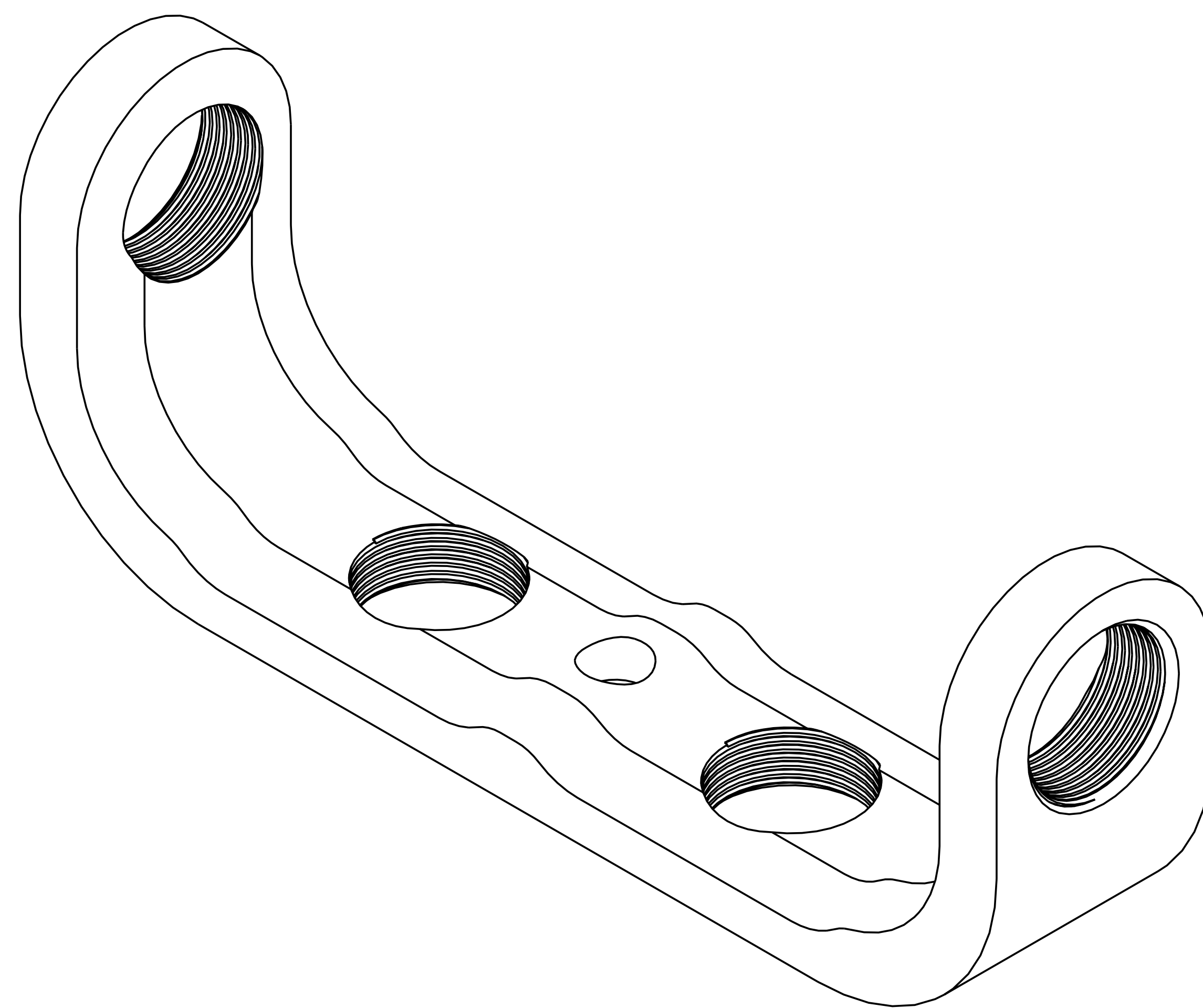
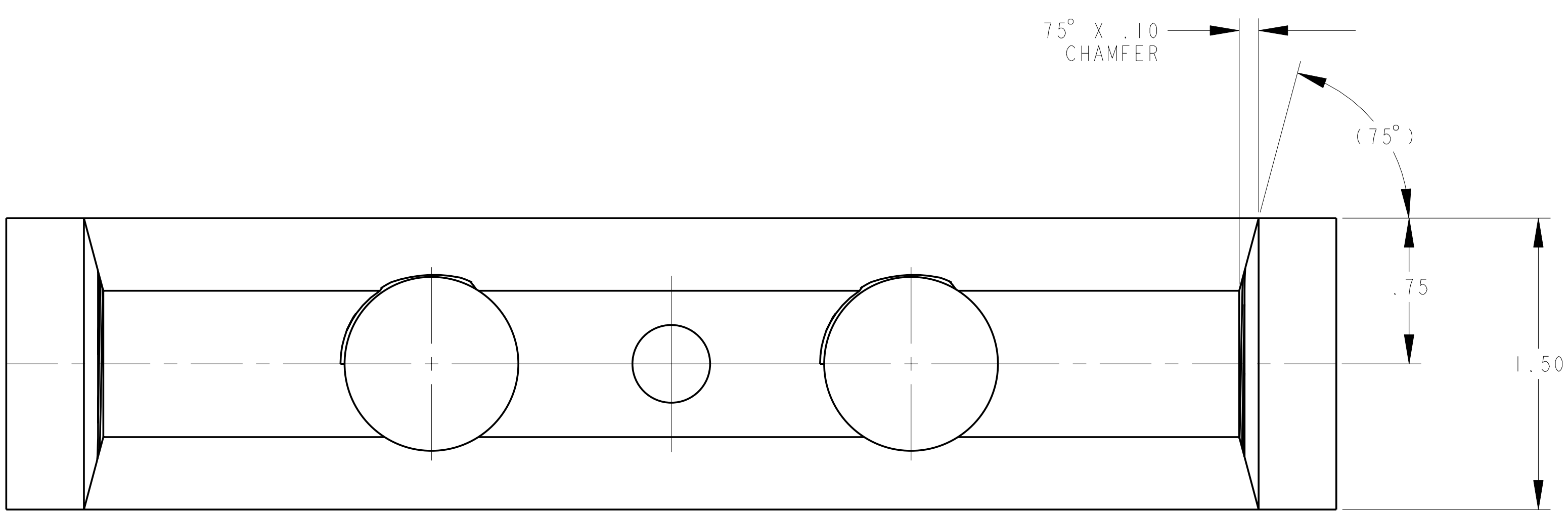

SECTION A-A

**RELEASED FOR  
FABRICATION / INSTALLATION**

AR	SEI405-254P	BAR, CLAMP, HORIZONTAL	316L SS	--	1
CAGE CODE	PART OR IDENTIFYING NO	NOMENCLATURE OR DESCRIPTION	MATERIAL	SPECIFICATION	FIND NO
SEI405-250					
← NEXT ASSEMBLY					

PARTS LIST

<p>NO REPRESENTATION OR WARRANTY, EXPRESSED OR IMPLIED, IS MADE AS TO THE ACCURACY, COMPLETENESS OR USEFULNESS OF THE INFORMATION OR STATEMENTS CONTAINED IN THESE DRAWINGS, OR THAT THE USE OR DISCLOSURE OF ANY INFORMATION, APPARATUS, METHOD OR PROCESS DISCLOSED IN THESE DRAWINGS MAY NOT INFRINGE PRIVATE RIGHTS OF OTHERS. NO LIABILITY IS ASSUMED WITH RESPECT TO THE USE OF, OR FOR DAMAGES RESULTING FROM THE USE OF, ANY INFORMATION, APPARATUS, METHOD OR PROCESS DISCLOSED IN THESE DRAWINGS. DRAWINGS MADE AVAILABLE FOR INFORMATION TO BIDDER ARE NOT TO BE USED FOR OTHER PURPOSES, AND ARE TO BE RETURNED UPON REQUEST OF THE FORWARDING CONTRACTOR.</p>										<p><b>P</b> THIS DRAWING PRODUCED ON PRO-ENGINEER</p>										<p>SCALE 2</p> <p>TOLERANCES UNLESS OTHERWISE SPECIFIED:</p> <p>FRACTIONS ± .01</p> <p>XX DECIMALS ± .01</p> <p>XXX DECIMALS ± .005</p> <p>ANGLES ± 0°15'</p> <p>BREAK SHARP EDGES 06 MAX</p> <p>FINISH :25 UNLESS OTHERWISE SPECIFIED</p>										<p>DES PAUL MILLER 4-12-04</p> <p>DRW PAUL MILLER 4-14-04</p> <p>CHK :  SEC :  DEPT :  PE :  CR :  PJ :  RD :</p> <p>PPPL DRFT :  DATE :</p>										<p>UT-BATTELLE  National Compact Stellarator Experiment</p> <p>Bar, Clamp, Horizontal</p> <p>VERSION NO. 3  PLANT X-10  BLDG 5700  FL 3  SHT 1  TYPE 1  CLASS U</p> <p>RELEASE LEVEL WIP</p>										<p>Oak Ridge National Laboratory managed for the DEPARTMENT OF ENERGY under U.S. GOVERNMENT contract DE-AC05-00OR22725 UT-BATTELLE, LLC. Oak Ridge, Tennessee</p>									
REV										DESCRIPTION										BY DATE CHK DEPT DATE PE REG DATE DRNL DOE DATE										REVISION APPROVAL																													
REVISION OR ISSUE PURPOSE																																																											

SEI405-254P

- NOTES:  
 1. INTERPRET DIMENSIONS AND TOLERANCES PER ANSI Y14.5M  
 2. DIMENSIONS ARE IN INCHES  
 3. DIMENSIONS APPLY AT ROOM TEMPERATURE. OPERATING TEMP 80 K  
 4. GEOMETRY IS DEFINED IN PRO ENGINEER CAD MODELS/FILES  
 5. DRAWING AND MODELS COMBINED DEFINE FINISHED MACHINED PART

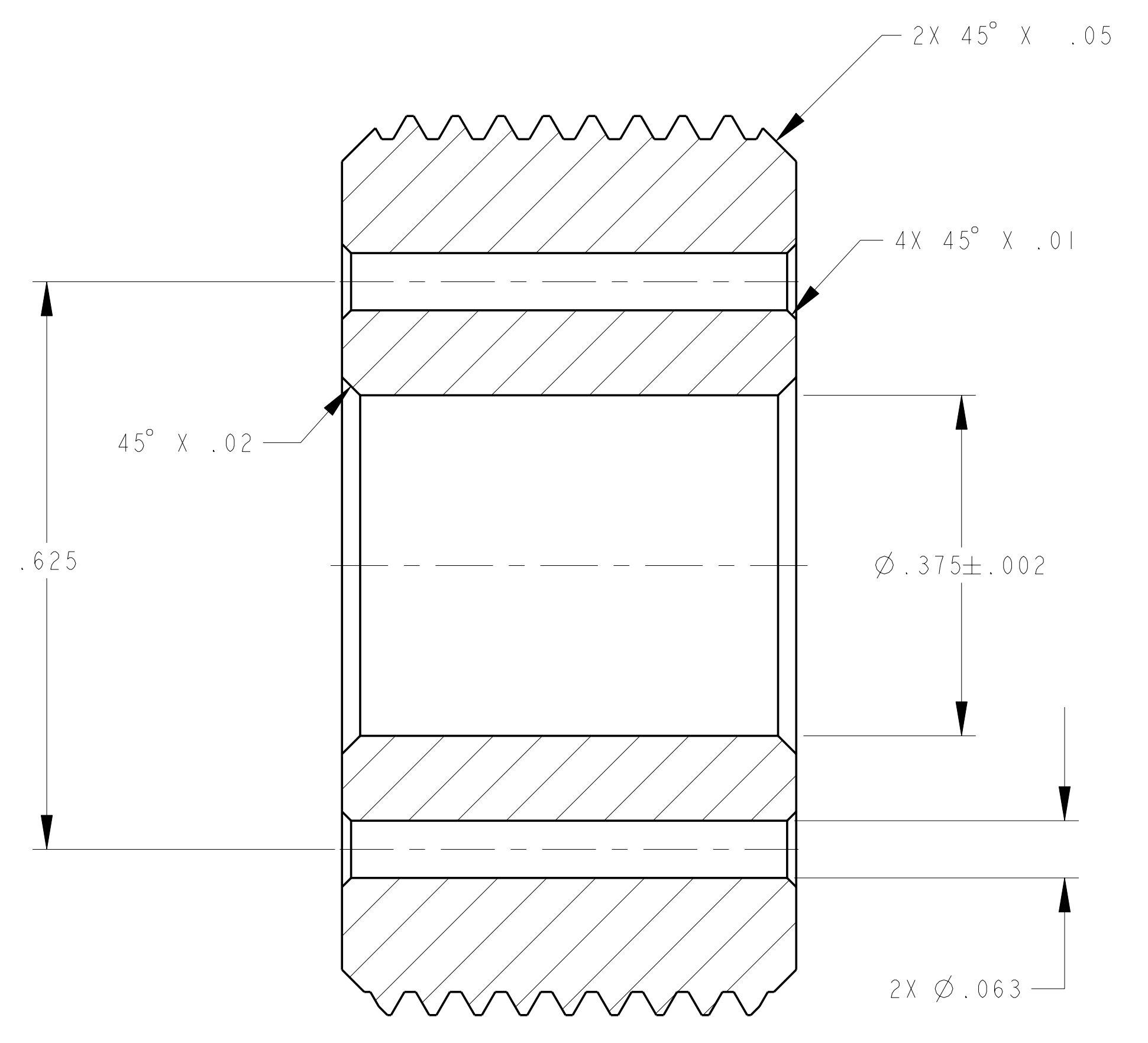
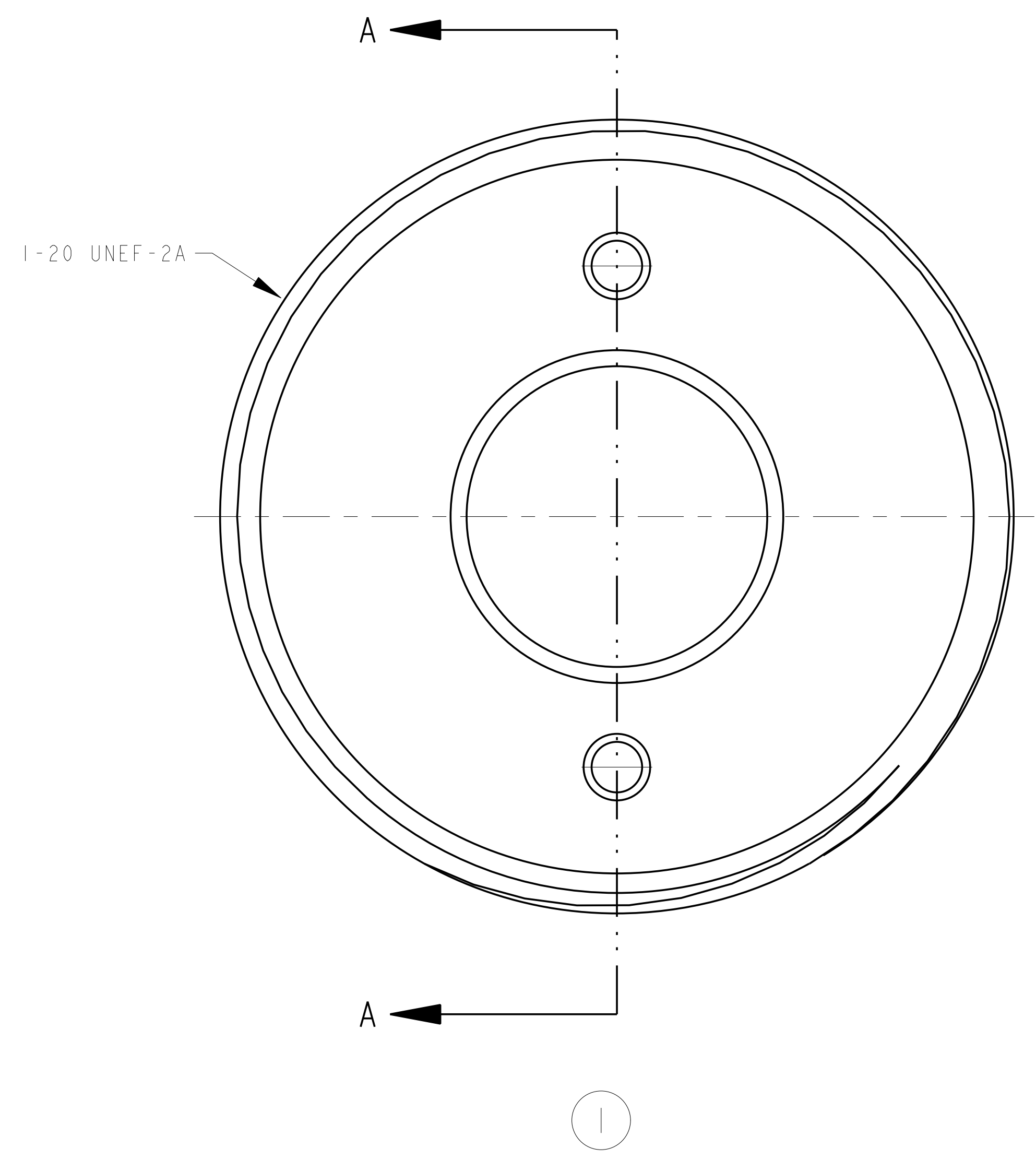
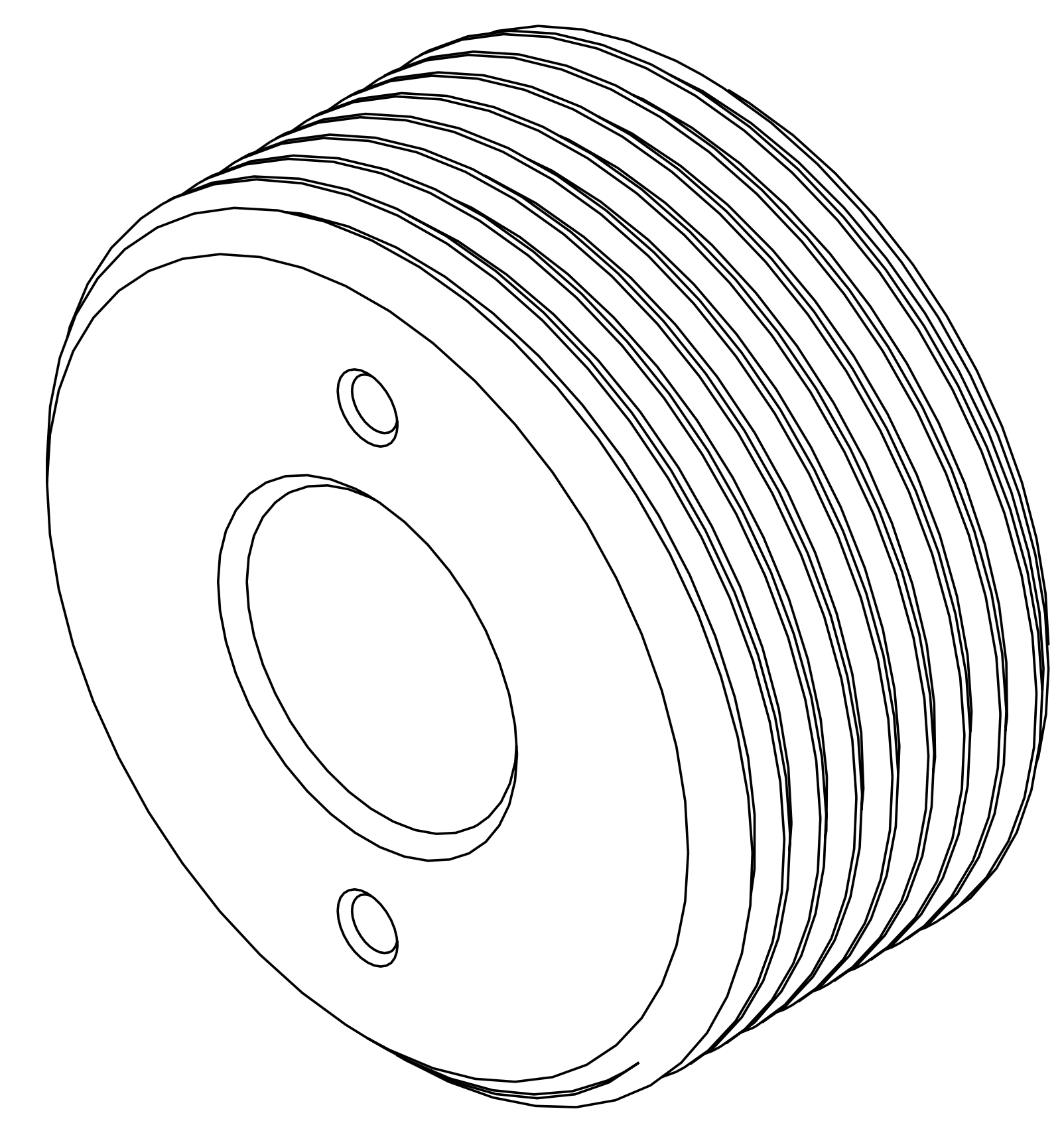
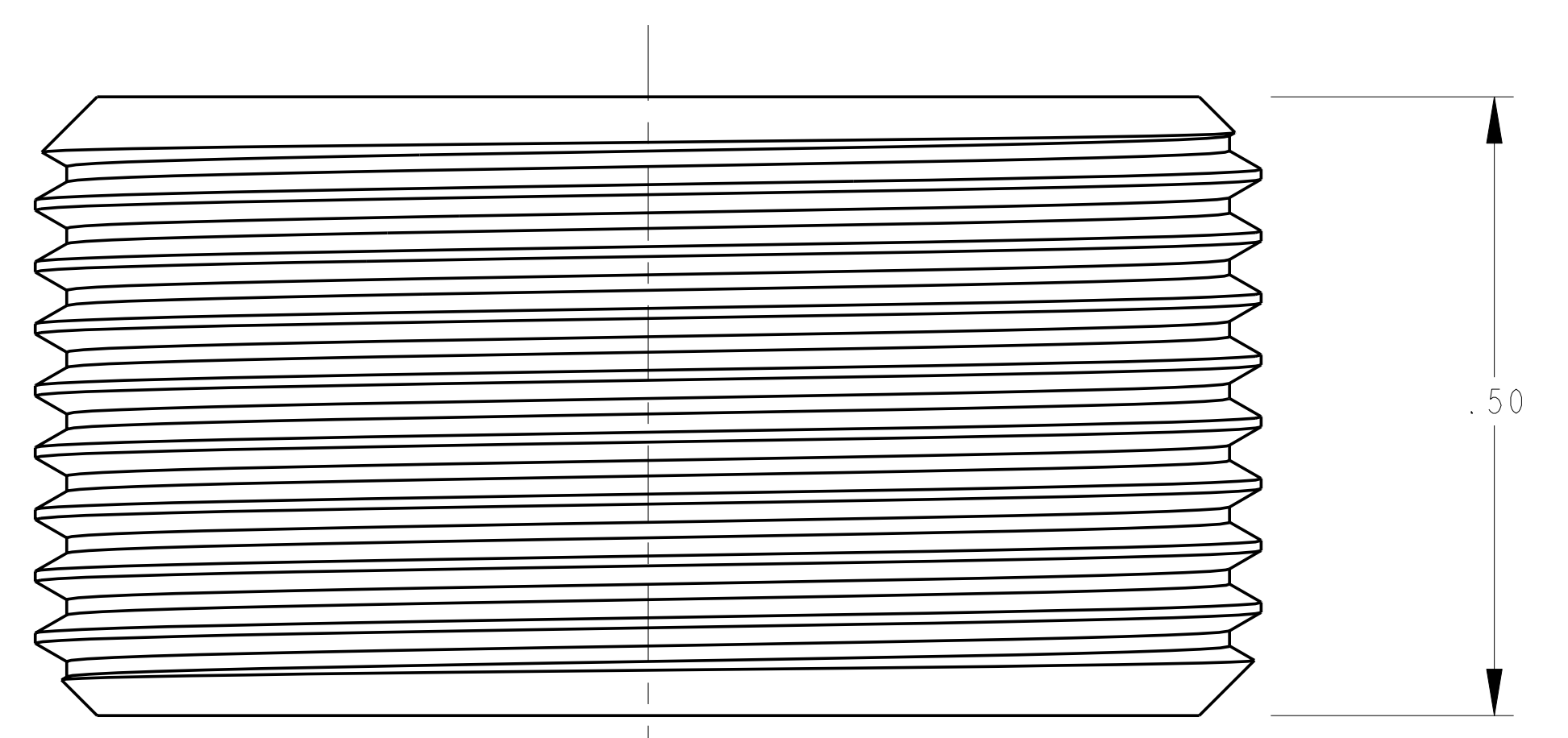

SECTION A-A

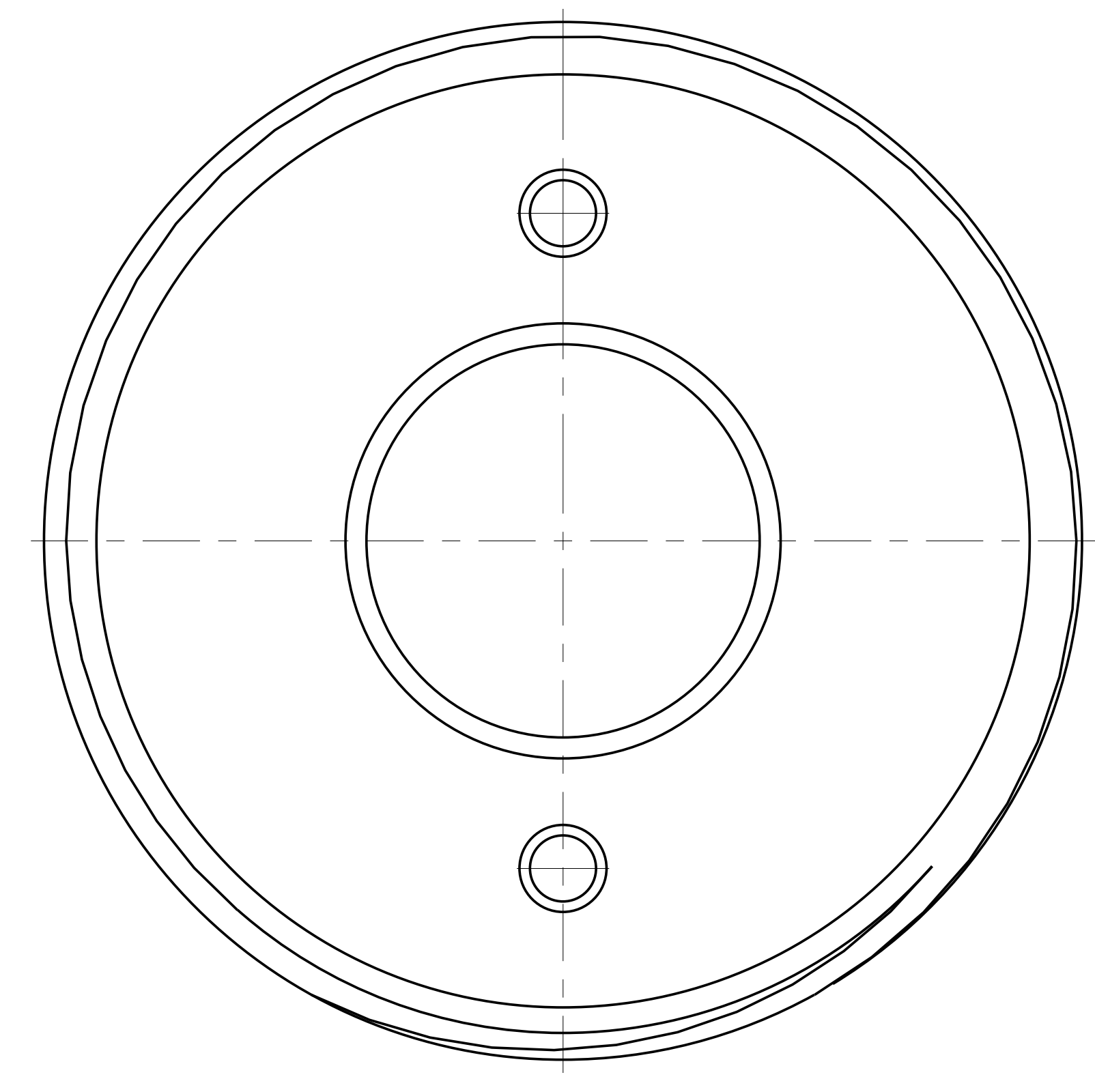

**RELEASED FOR FABRICATION / INSTALLATION**

AR	SEI405-255P	SCREW, SET, 1-20 UNEF-2A X 1/2	316L SS AG PLATED	---	1
CAGE CODE	PART OR IDENTIFYING NO	NOMENCLATURE OR DESCRIPTION	MATERIAL	SPECIFICATION	FIND NO
SEI405-250	← NEXT ASSEMBLY	PARTS LIST			

NO REPRESENTATION OR WARRANTY, EXPRESSED OR IMPLIED, IS MADE AS TO THE ACCURACY, COMPLETENESS OR USEFULNESS OF THE INFORMATION OR STATEMENTS CONTAINED IN THESE DRAWINGS, OR THAT THE USE OR DISCLOSURE OF ANY INFORMATION, APPARATUS, METHOD OR PROCESS DISCLOSED IN THESE DRAWINGS MAY NOT INFRINGE PRIVATE RIGHTS OF OTHERS. NO LIABILITY IS ASSUMED WITH RESPECT TO THE USE OF, OR FOR DAMAGES RESULTING FROM THE USE OF, ANY INFORMATION, APPARATUS, METHOD OR PROCESS DISCLOSED IN THESE DRAWINGS. DRAWINGS MADE AVAILABLE FOR INFORMATION TO BIDDER ARE NOT TO BE USED FOR OTHER PURPOSES, AND ARE TO BE RETURNED UPON REQUEST OF THE FORWARDING CONTRACTOR.

**P** THIS DRAWING PRODUCED ON PRO-ENGINEER

REV	DESCRIPTION	BY	DATE	CHK	DEPT	DATE	PE	REG	DATE	DRNL	DOE	DATE
	REVISION OR ISSUE PURPOSE											

SCALE 8	DES PAUL MILLER 4-12-04	<b>UT-BATTELLE</b> Oak Ridge National Laboratory managed for the DEPARTMENT OF ENERGY under U.S. GOVERNMENT contract DE-AC05-00OR22725 UT-BATTELLE, LLC, Oak Ridge, Tennessee PROJECT NAME <b>NATIONAL COMPACT STELLARATOR EXPERIMENT</b>
TOLERANCES UNLESS OTHERWISE SPECIFIED	DRW PAUL MILLER 4-13-04	
FRACTIONS	CHK	
XX DECIMALS ± .01	SECT	
XXX DECIMALS ± .005	DEPT	
ANGLES ± 0°15'	PE	VERSION NO. 3
FINISH .125 UNLESS OTHERWISE SPECIFIED	CR	PLANT X-10
	PJ	BLDG 5700
	REG	FL 3
	DRFT	SHT OF 1
		TYPE 1 S
		CLASS U
		RELEASE LEVEL WIP
		SEI405-255P
		REV 0

SEI405-255P



- NOTES:
- 1. INTERPRET DIMENSIONS AND TOLERANCES PER ANSI Y14.5M
  - 2. DIMENSIONS ARE IN INCHES
  - 3. DIMENSIONS APPLY AT ROOM TEMPERATURE. OPERATING TEMP 80 K
  - 4. GEOMETRY IS DEFINED IN PRO ENGINEER CAD MODELS/FILES
  - 5. DRAWING AND MODELS COMBINED DEFINE FINISHED MACHINED PART
  - 6. PART MUST BE ANNEALED AFTER MACHINING

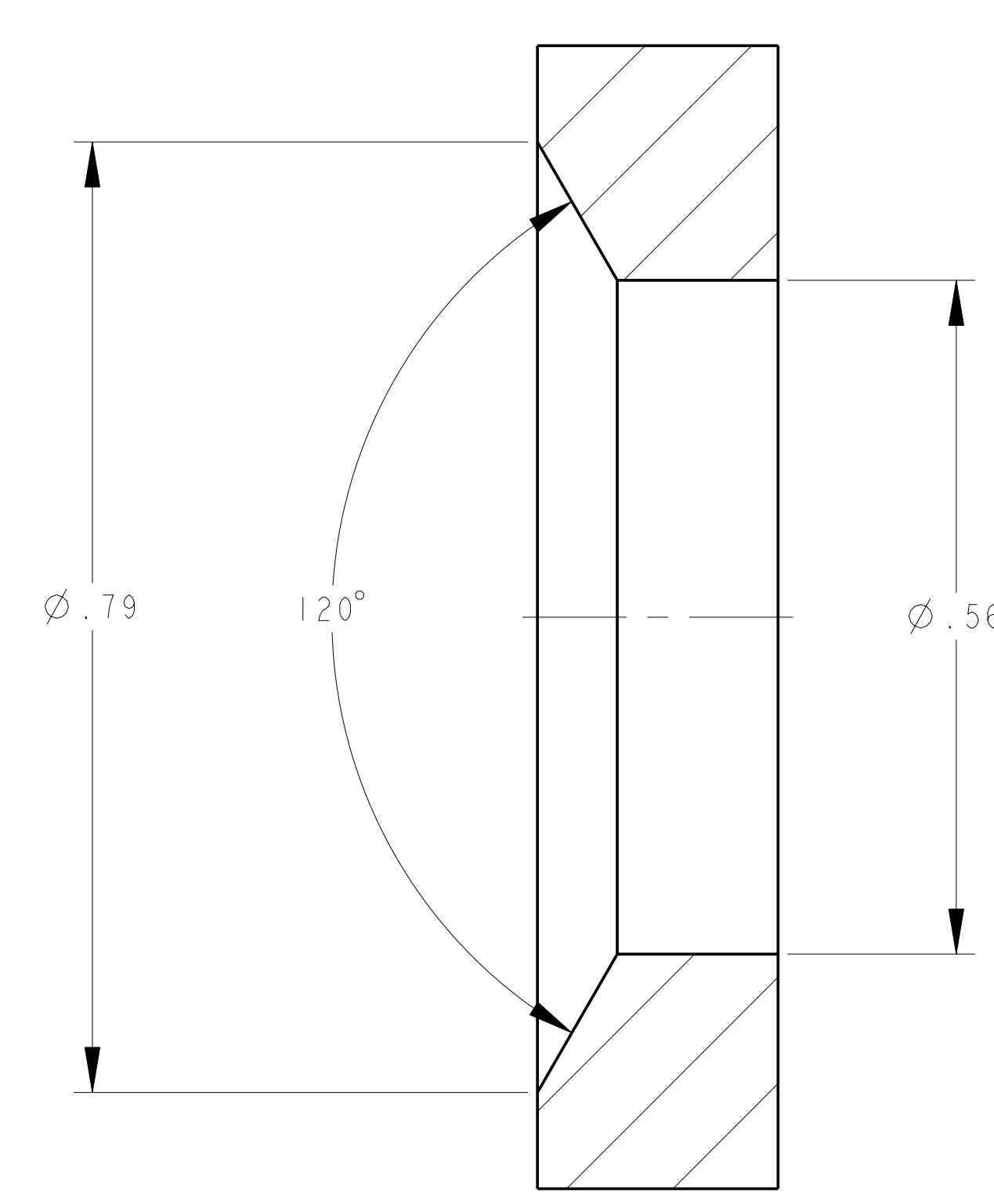
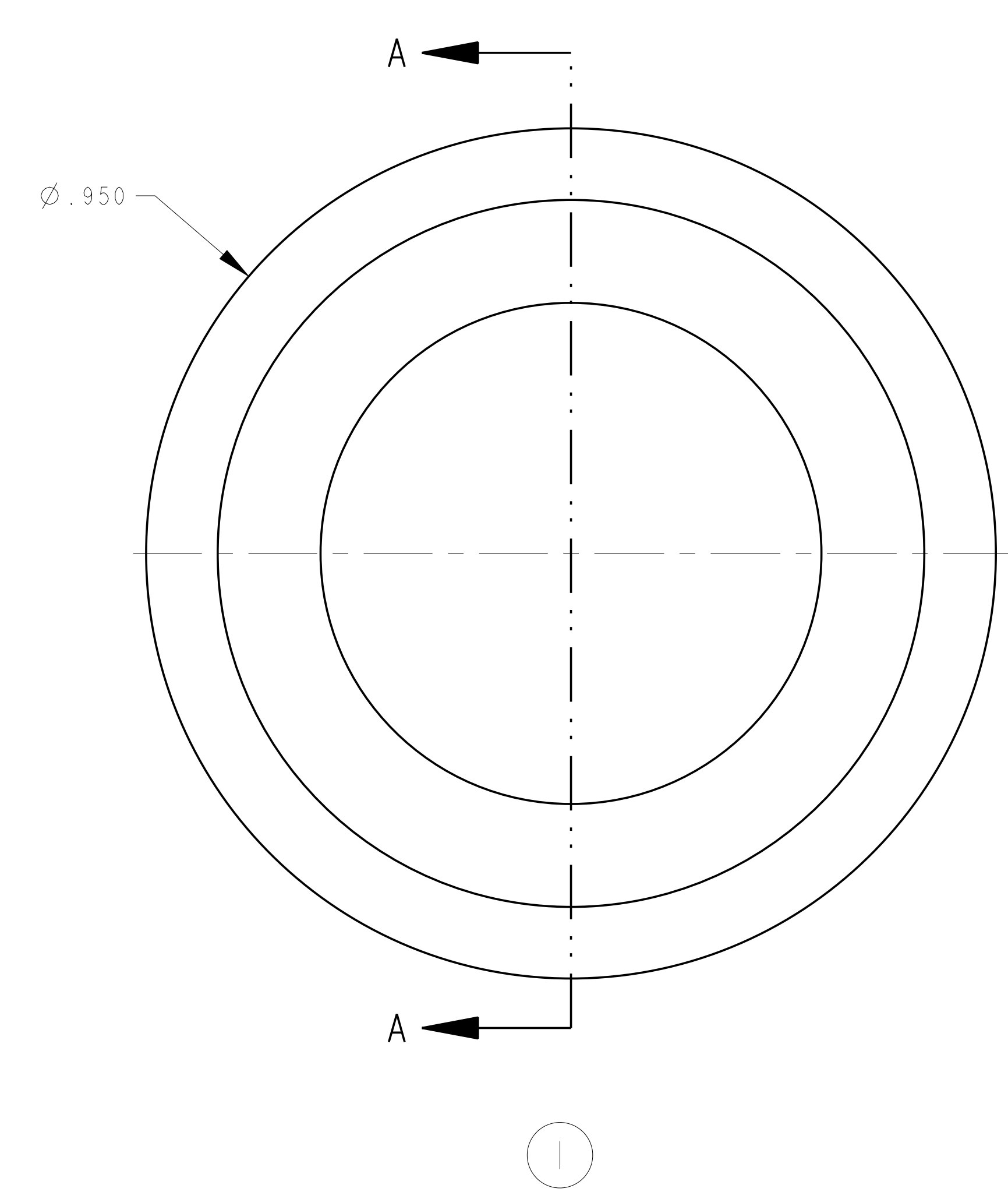
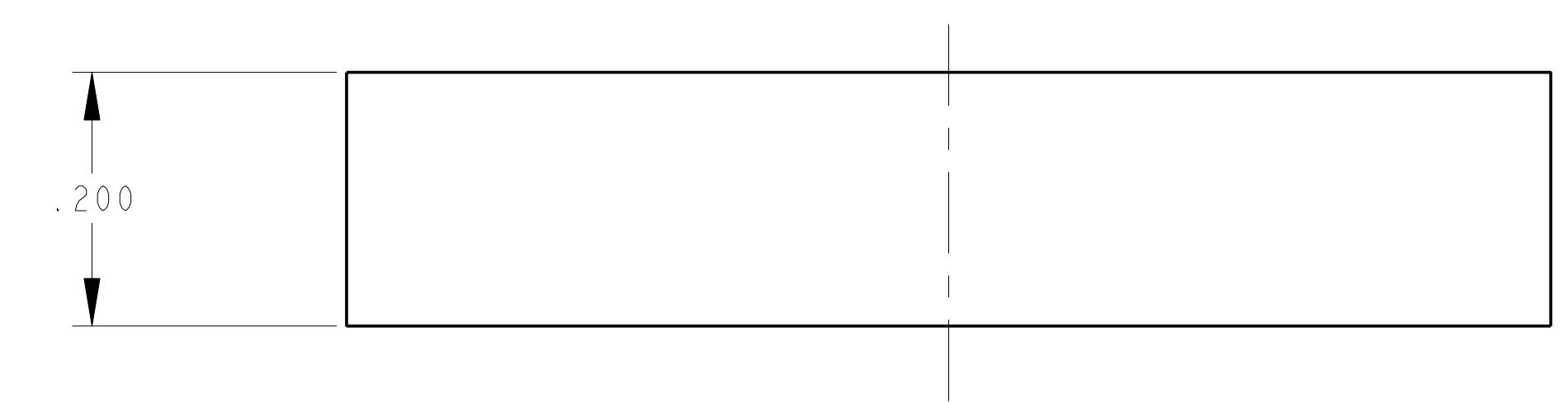

SECTION A-A

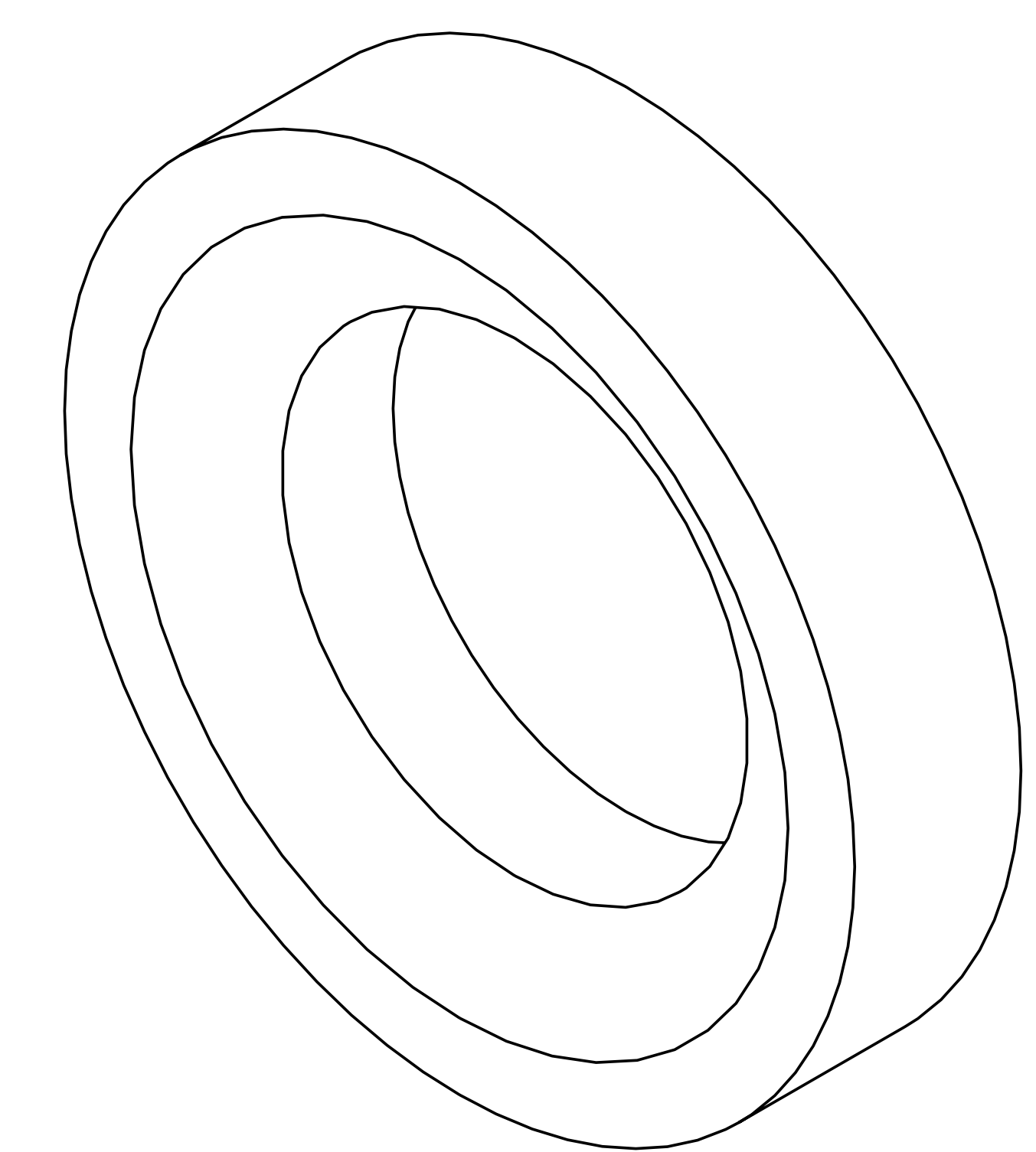

**RELEASED FOR  
FABRICATION / INSTALLATION**

AR	SEI405-257P	WASHER, SPHERICAL, TYPE D	303 SS ANNEALED	DIN 6319	I	
SEI405-250	CAGE CODE	PART OR IDENTIFYING NO	NOMENCLATURE OR DESCRIPTION	MATERIAL	SPECIFICATION	FIND NO
←						

← NEXT ASSEMBLY

PARTS LIST

NO REPRESENTATION OR WARRANTY, EXPRESSED OR IMPLIED, IS MADE AS TO THE ACCURACY, COMPLETENESS OR USEFULNESS OF THE INFORMATION OR STATEMENTS CONTAINED IN THESE DRAWINGS, OR THAT THE USE OR DISCLOSURE OF ANY INFORMATION, APPARATUS, METHOD OR PROCESS DISCLOSED IN THESE DRAWINGS MAY NOT INFRINGE PRIVATE RIGHTS OF OTHERS. NO LIABILITY IS ASSUMED WITH RESPECT TO THE USE OF, OR FOR DAMAGES RESULTING FROM THE USE OF, ANY INFORMATION, APPARATUS, METHOD OR PROCESS DISCLOSED IN THESE DRAWINGS. DRAWINGS MADE AVAILABLE FOR INFORMATION TO BIDDER ARE NOT TO BE USED FOR OTHER PURPOSES, AND ARE TO BE RETURNED UPON REQUEST OF THE FORWARDING CONTRACTOR.

**P** THIS DRAWING PRODUCED ON PRO-ENGINEER

REV	DESCRIPTION	BY	DATE	CHK	DEPT	DATE	PE	REQ	DATE	DRNL	DOE	DATE

SCALE	8
TOLERANCES UNLESS OTHERWISE SPECIFIED	
FRACTIONS	
XX DECIMALS	± .01
XXX DECIMALS	± .005
ANGLES	± 0'15"
FINISH	.125 UNLESS OTHERWISE SPECIFIED
BREAK SHARP EDGES	06 MAX

DES: PAUL MILLER 4-12-04  
DRW: PAUL MILLER 4-14-04

**UT-BATTELLE**  
Oak Ridge National Laboratory  
managed for the DEPARTMENT OF ENERGY under  
U.S. GOVERNMENT contract DE-AC05-00OR22725  
UT-BATTELLE, LLC, Oak Ridge, Tennessee

**NATIONAL COMPACT STELLARATOR EXPERIMENT**

WASHER, SPHERICAL, TYPE D

PPPL DRFT	VERSION NO.	PLANT	BLDG	FL	SHT OF	TYPE	CLASS
	3	X-10	5700	3	1	I S	U
		RELEASE LEVEL					REV
		Fabrication					0

SEI405-257P

- NOTES:
1. INTERPRET DIMENSIONS AND TOLERANCES PER ANSI Y14.5M
  2. DIMENSIONS ARE IN INCHES
  3. DIMENSIONS APPLY AT ROOM TEMPERATURE. OPERATING TEMP 80 K
  4. GEOMETRY IS DEFINED IN PRO ENGINEER CAD MODELS/FILES
  5. DRAWING AND MODELS COMBINED DEFINE FINISHED MACHINED PART
  6. SPRING CONSTANT K=7600 LBS/IN

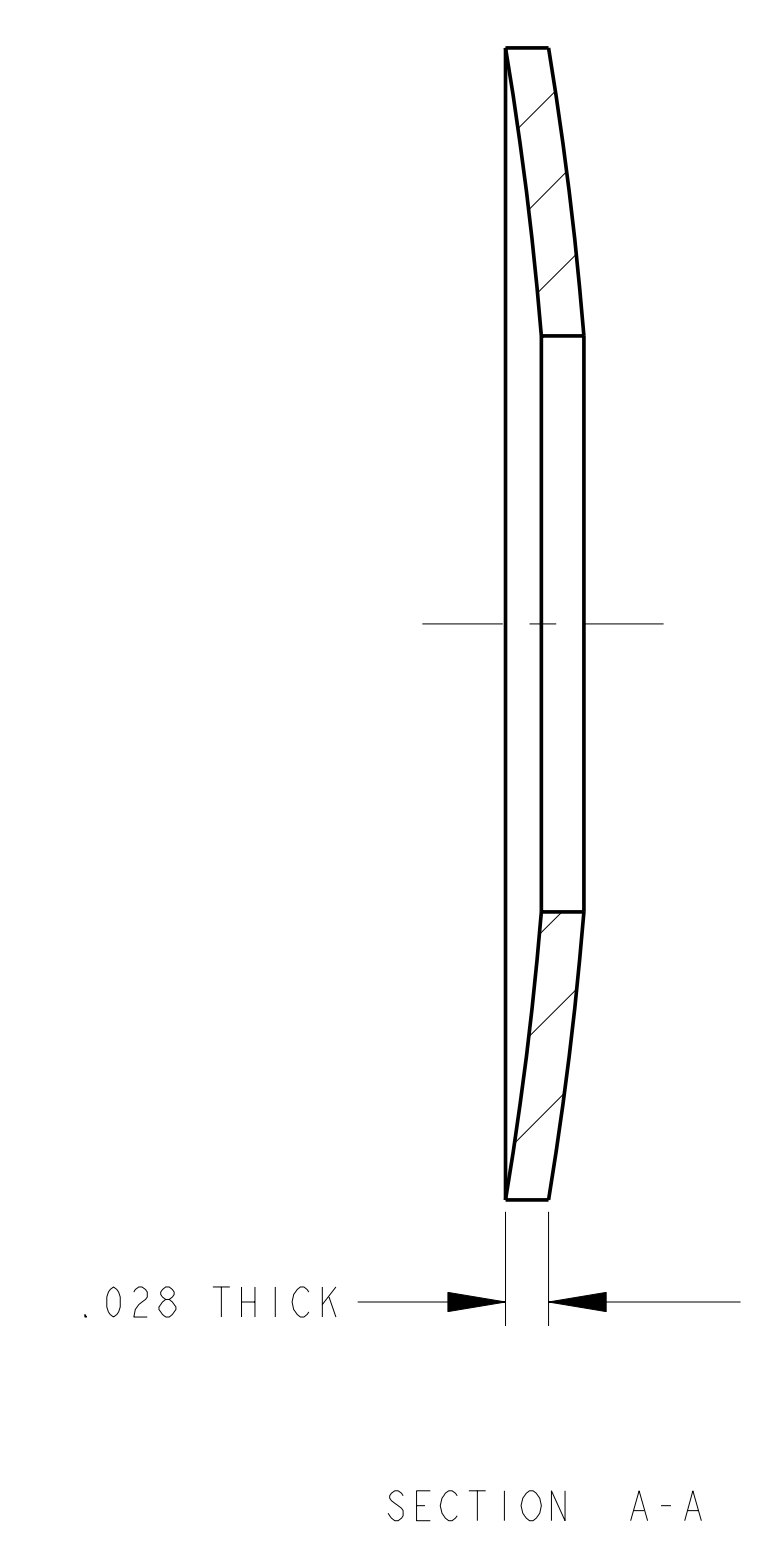
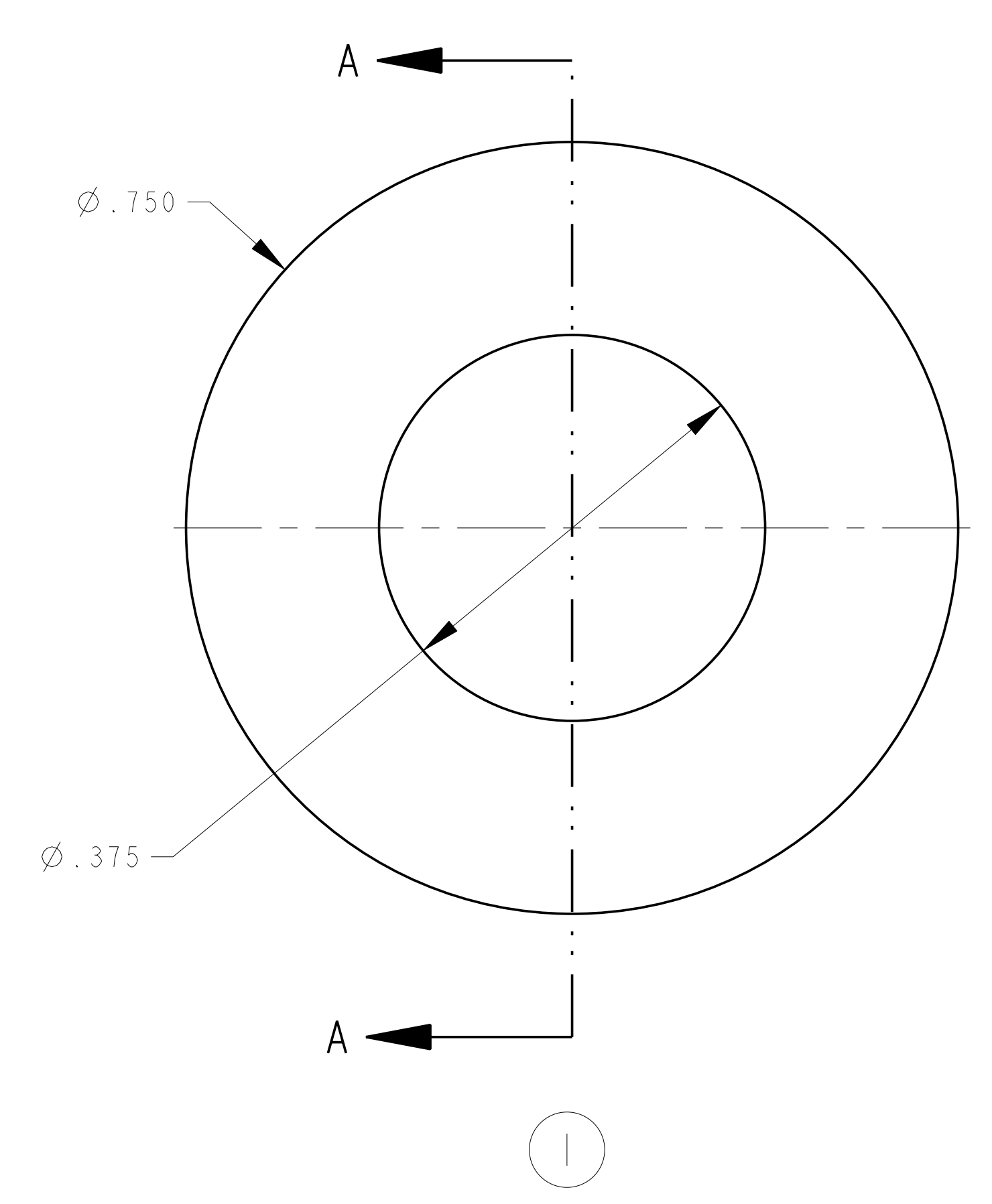
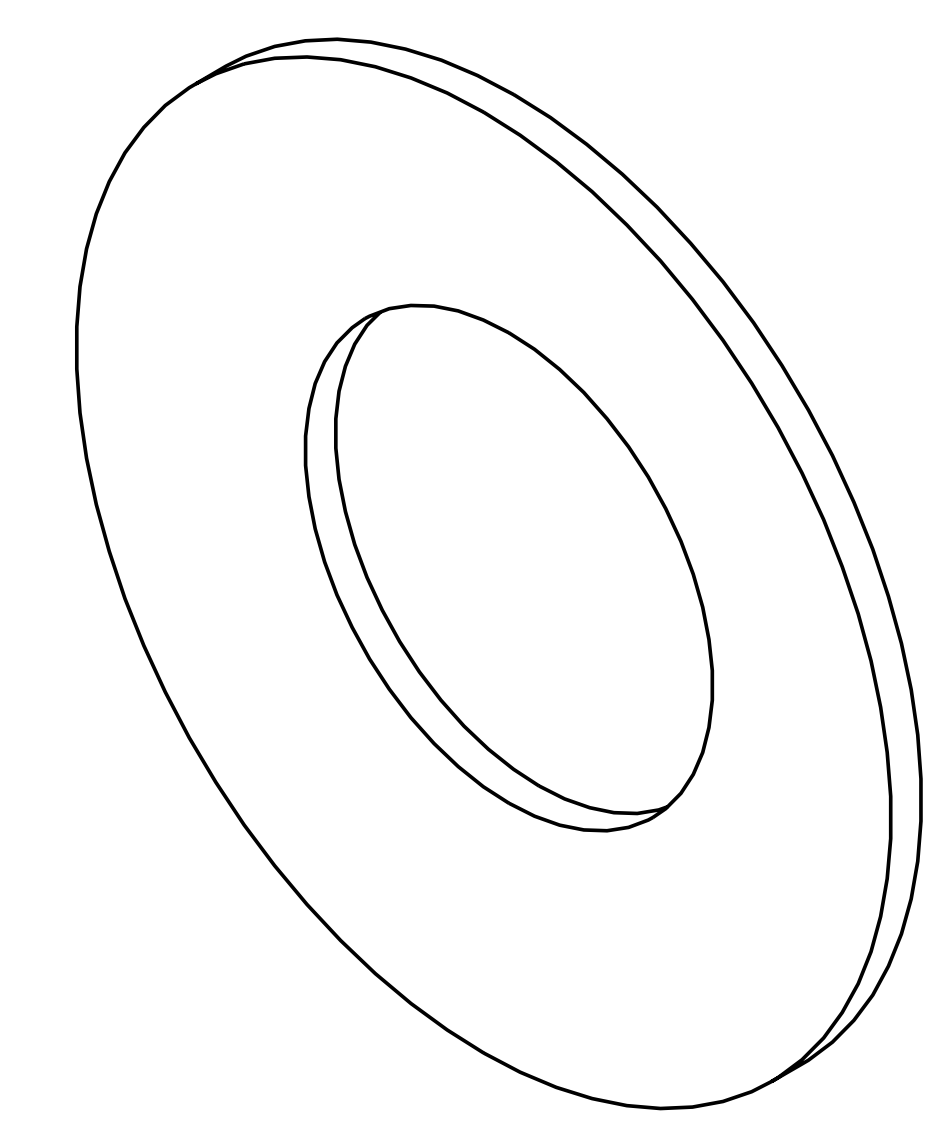
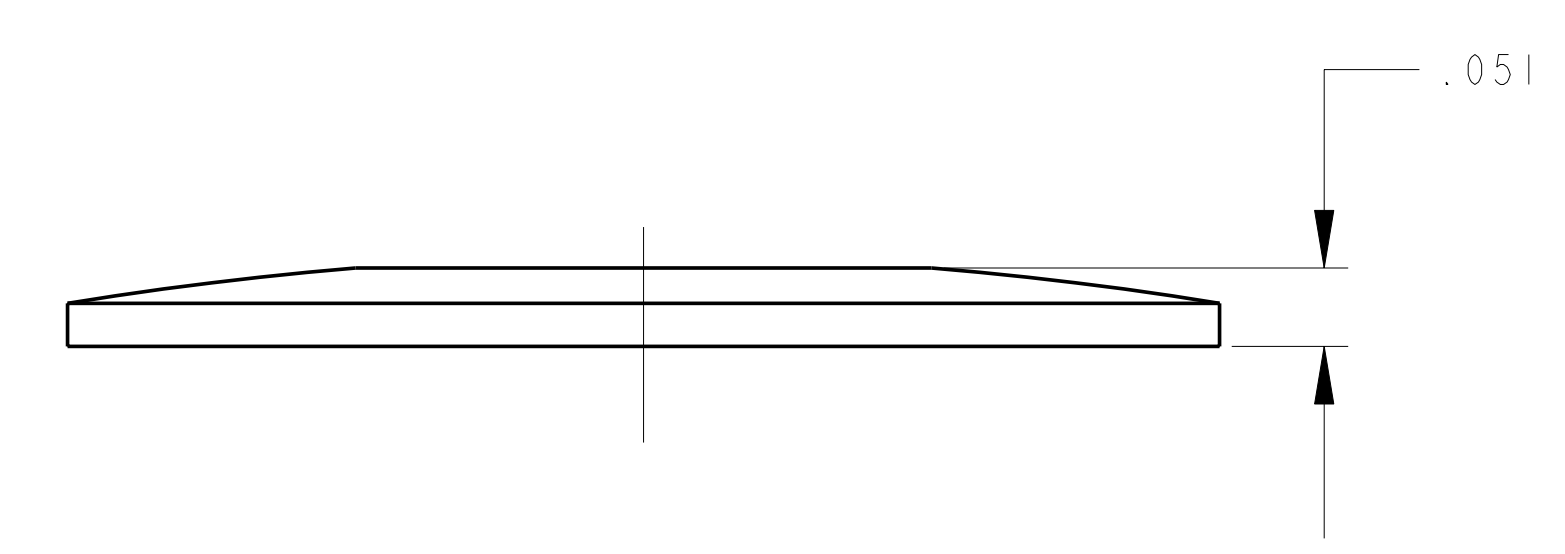

**RELEASED FOR FABRICATION / INSTALLATION**

AR	SEI405-258P	WASHER, BELLEVILLE, 3/4 OD, 3/8 ID	BERYLLIUM COPPER	K=7600 LBS/IN	
SEI405-258	CAGE CODE	PART OR IDENTIFYING NO	NOMENCLATURE OR DESCRIPTION	MATERIAL	SPECIFICATION
					FIND NO

← NEXT ASSEMBLY

PARTS LIST

NO REPRESENTATION OR WARRANTY, EXPRESSED OR IMPLIED, IS MADE AS TO THE ACCURACY, COMPLETENESS OR USEFULNESS OF THE INFORMATION OR STATEMENTS CONTAINED IN THESE DRAWINGS, OR THAT THE USE OR DISCLOSURE OF ANY INFORMATION, APPARATUS, METHOD OR PROCESS DISCLOSED IN THESE DRAWINGS MAY NOT INFRINGE PRIVATE RIGHTS OF OTHERS. NO LIABILITY IS ASSUMED WITH RESPECT TO THE USE OF, OR FOR DAMAGES RESULTING FROM THE USE OF, ANY INFORMATION, APPARATUS, METHOD OR PROCESS DISCLOSED IN THESE DRAWINGS. DRAWINGS MADE AVAILABLE FOR INFORMATION TO BIDDER ARE NOT TO BE USED FOR OTHER PURPOSES, AND ARE TO BE RETURNED UPON REQUEST OF THE FORWARDING CONTRACTOR.

**P** THIS DRAWING PRODUCED ON PRO-ENGINEER

REV	DESCRIPTION	BY	DATE	CHK	DEPT	DATE	PE	REQ	DATE	ORNL	DOE	DATE
	REVISION OR ISSUE PURPOSE											

SCALE: 8

TOLERANCES UNLESS OTHERWISE SPECIFIED:  
 FRACTIONS: ±.01  
 XX DECIMALS: ±.005  
 XXX DECIMALS: ±.0015  
 ANGLES: ±0°15'  
 BREAK SHARP EDGES: .06 MAX  
 FINISH: .125 UNLESS OTHERWISE SPECIFIED

DES: PAUL MILLER 4-12-04  
 DRW: PAUL MILLER 4-14-04  
 CHK: :  
 SECT: :  
 DEPT: :  
 PE: :  
 CR: :  
 PJ: :  
 RED: :  
 PPPL DRFT: :  
 :  
 :  
 DRAWING APPROVALS: :  
 DATE: :

Oak Ridge National Laboratory  
 managed for the DEPARTMENT OF ENERGY under  
 U.S. GOVERNMENT contract DE-AC05-00OR22725  
 UT-BATTELLE, LLC. Oak Ridge, Tennessee  
 PROJECT NAME: NATIONAL COMPACT STELLARATOR EXPERIMENT

WASHER, BELLEVILLE, 3/4 OD, 3/8 ID

VERSION NO.	PLANT	BLDG	FL	SHT OF	TYPE	CLASS
3	X-10	5700	3	1	S	U

RELEASE LEVEL: WIP

SEI405-258P

REV 0

- NOTES:
1. INTERPRET DIMENSIONS AND TOLERANCES PER ANSI Y14.5M
  2. DIMENSIONS ARE IN INCHES
  3. DIMENSIONS APPLY AT ROOM TEMPERATURE. OPERATING TEMP 80 K
  4. GEOMETRY IS DEFINED IN PRO ENGINEER CAD MODELS/FILES
  5. DRAWING AND MODELS COMBINED DEFINE FINISHED MACHINED PART

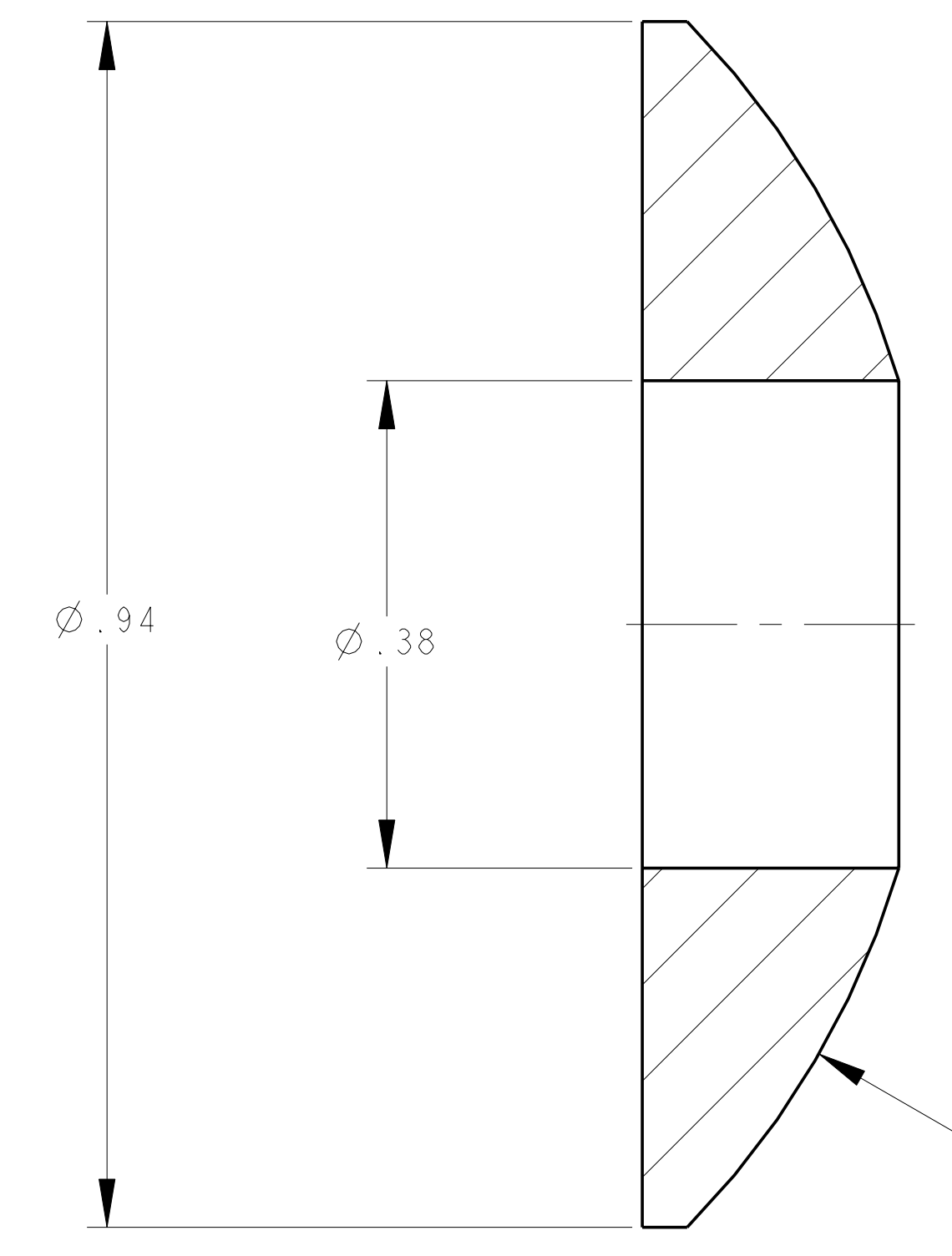
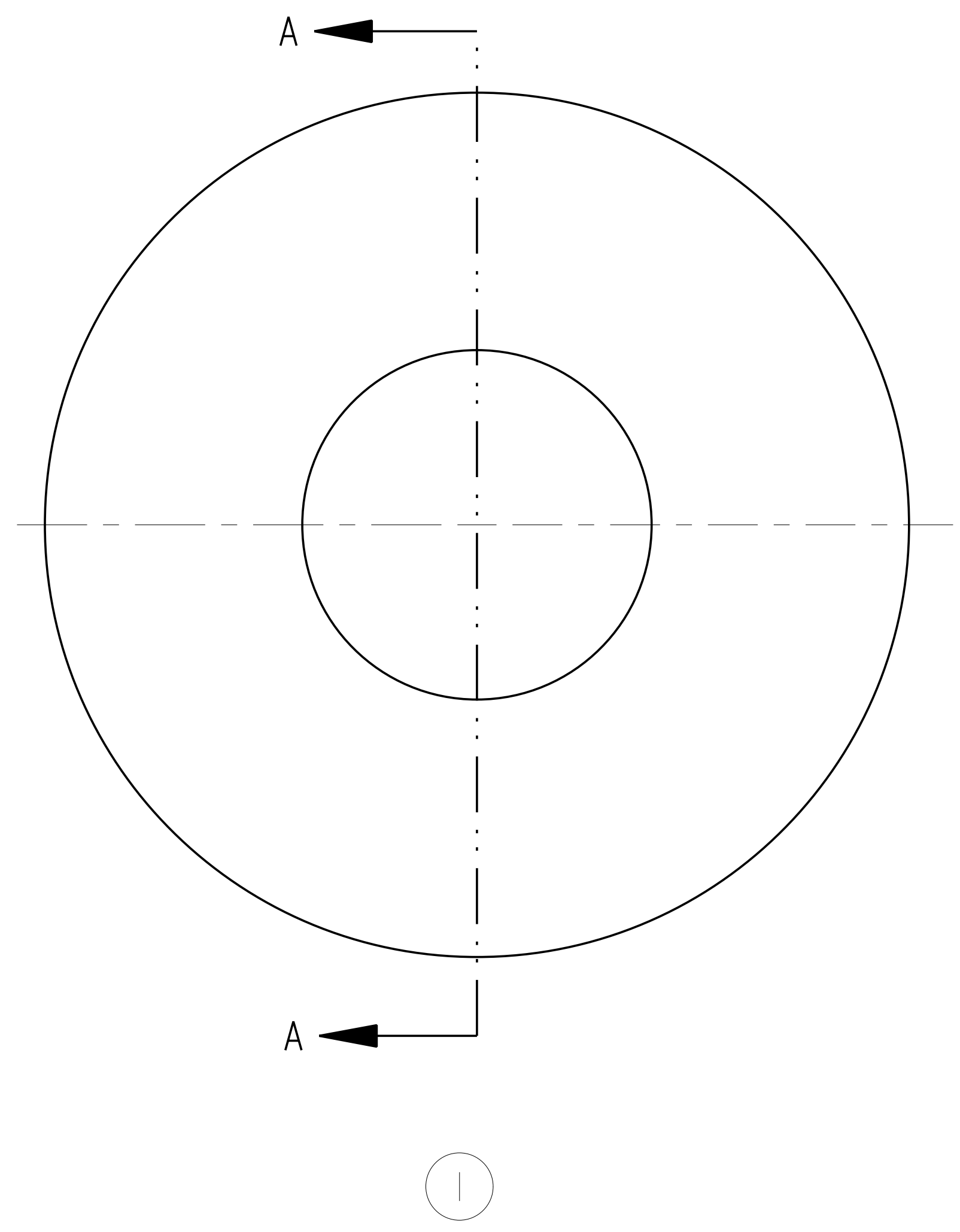
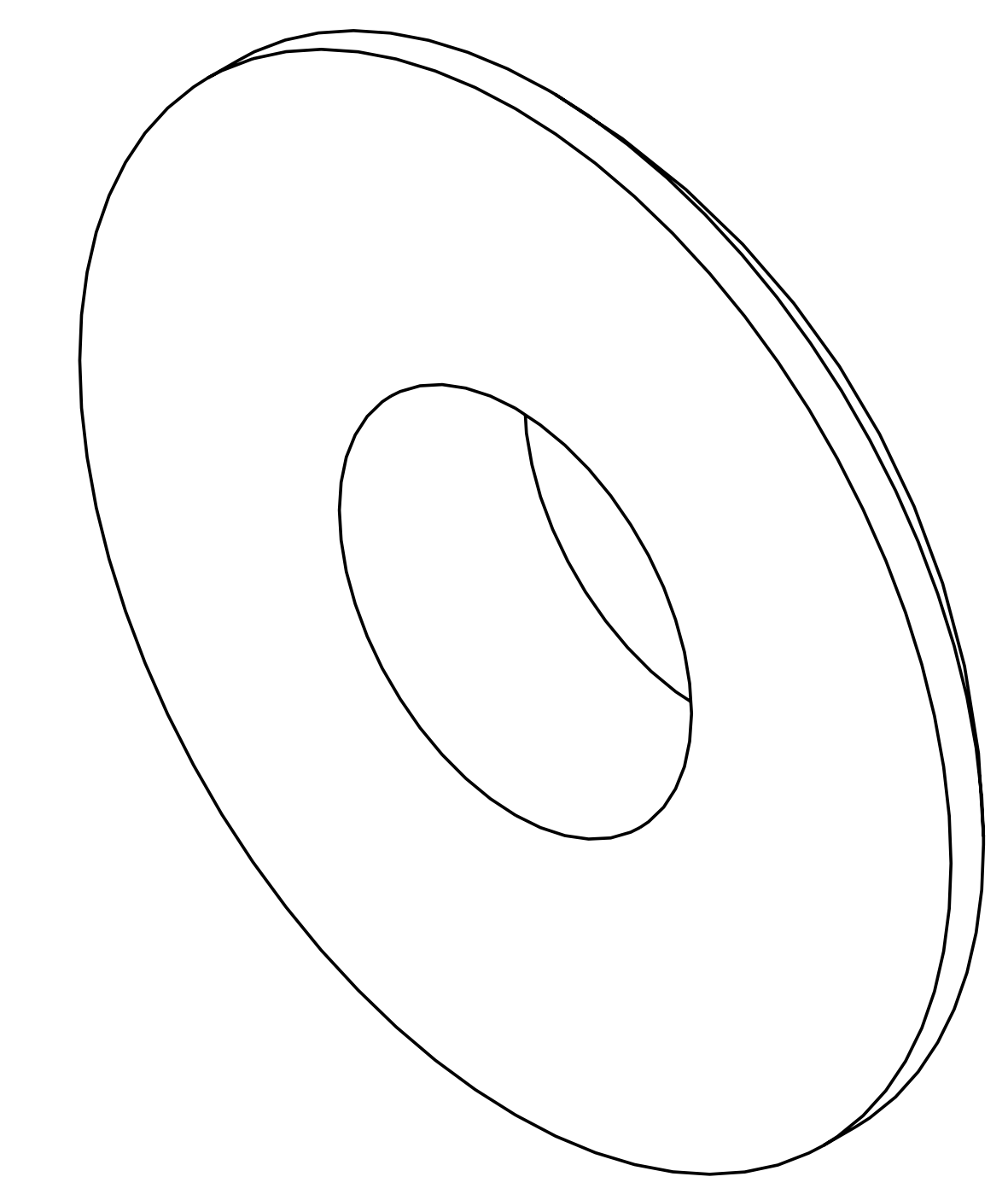
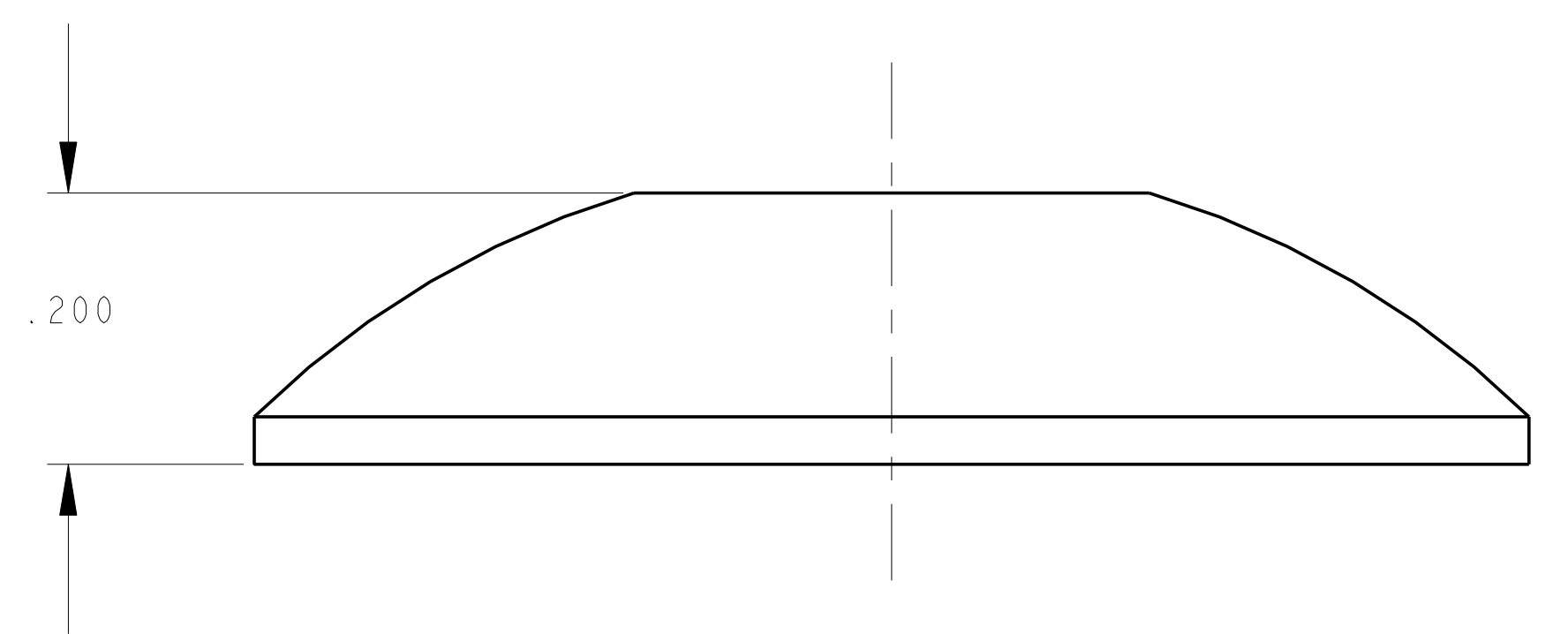

R.670 SPHERICAL RADIUS TO MATE WITH DIN 6319-NI TYPE D SPHERICAL WASHER

SECTION A-A

**RELEASED FOR FABRICATION / INSTALLATION**

AR	SEI405-259P	WASHER, SPHERICAL, TYPE C	A286 SUPERALLOY	DIN 6319 MODIFIED	I	
SEI405-250	CAGE CODE	PART OR IDENTIFYING NO	NOMENCLATURE OR DESCRIPTION	MATERIAL	SPECIFICATION	FIND NO

← NEXT ASSEMBLY

PARTS LIST

NO REPRESENTATION OR WARRANTY, EXPRESSED OR IMPLIED, IS MADE AS TO THE ACCURACY, COMPLETENESS OR USEFULNESS OF THE INFORMATION OR STATEMENTS CONTAINED IN THESE DRAWINGS, OR THAT THE USE OR DISCLOSURE OF ANY INFORMATION, APPARATUS, METHOD OR PROCESS DISCLOSED IN THESE DRAWINGS MAY NOT INFRINGE PRIVATE RIGHTS OF OTHERS. NO LIABILITY IS ASSUMED WITH RESPECT TO THE USE OF, OR FOR DAMAGES RESULTING FROM THE USE OF, ANY INFORMATION, APPARATUS, METHOD OR PROCESS DISCLOSED IN THESE DRAWINGS. DRAWINGS MADE AVAILABLE FOR INFORMATION TO BIDDER ARE NOT TO BE USED FOR OTHER PURPOSES, AND ARE TO BE RETURNED UPON REQUEST OF THE FORWARDING CONTRACTOR.

**P** THIS DRAWING PRODUCED ON PRO-ENGINEER

REV	DESCRIPTION	BY	DATE	CHK	DEPT	DATE	PE	REQ	DATE	ORNL	DOE	DATE

SCALE: 8

TOLERANCES UNLESS OTHERWISE SPECIFIED:

FRACTIONS: ±.01

XX DECIMALS: ±.005

XXX DECIMALS: ±.0015

ANGLES: ±0°15'

FINISH: .125 UNLESS OTHERWISE SPECIFIED

DES: PAUL MILLER 4-12-04

DRW: PAUL MILLER 4-14-04

CHK: :  
SECT: :  
DEPT: :  
PE: :  
CR: :  
PJ: :  
RD: :

PPPL DRFT :  
: :  
: :

VERSION NO. 3

PLANT X-10

BLDG 5700

FL 3

SHT OF 1

TYPE I

CLASS S

U

RELEASE LEVEL Fabrication

SEI405-259P

REV 0

Oak Ridge National Laboratory managed for the DEPARTMENT OF ENERGY under U.S. GOVERNMENT contract DE-AC05-00OR22725 UT-BATTELLE, LLC. Oak Ridge, Tennessee

PROJECT NAME: NATIONAL COMPACT STELLARATOR EXPERIMENT

WASHER, SPHERICAL, TYPE C



- NOTES:
1. INTERPRET DIMENSIONS AND TOLERANCES PER ANSI Y14.5M
  2. DIMENSIONS ARE IN INCHES
  3. DIMENSIONS APPLY AT ROOM TEMPERATURE. OPERATING TEMP 80 K
  4. GEOMETRY IS DEFINED IN PRO ENGINEER CAD MODELS/FILES
  5. DRAWING AND MODELS COMBINED DEFINE FINISHED MACHINED PART

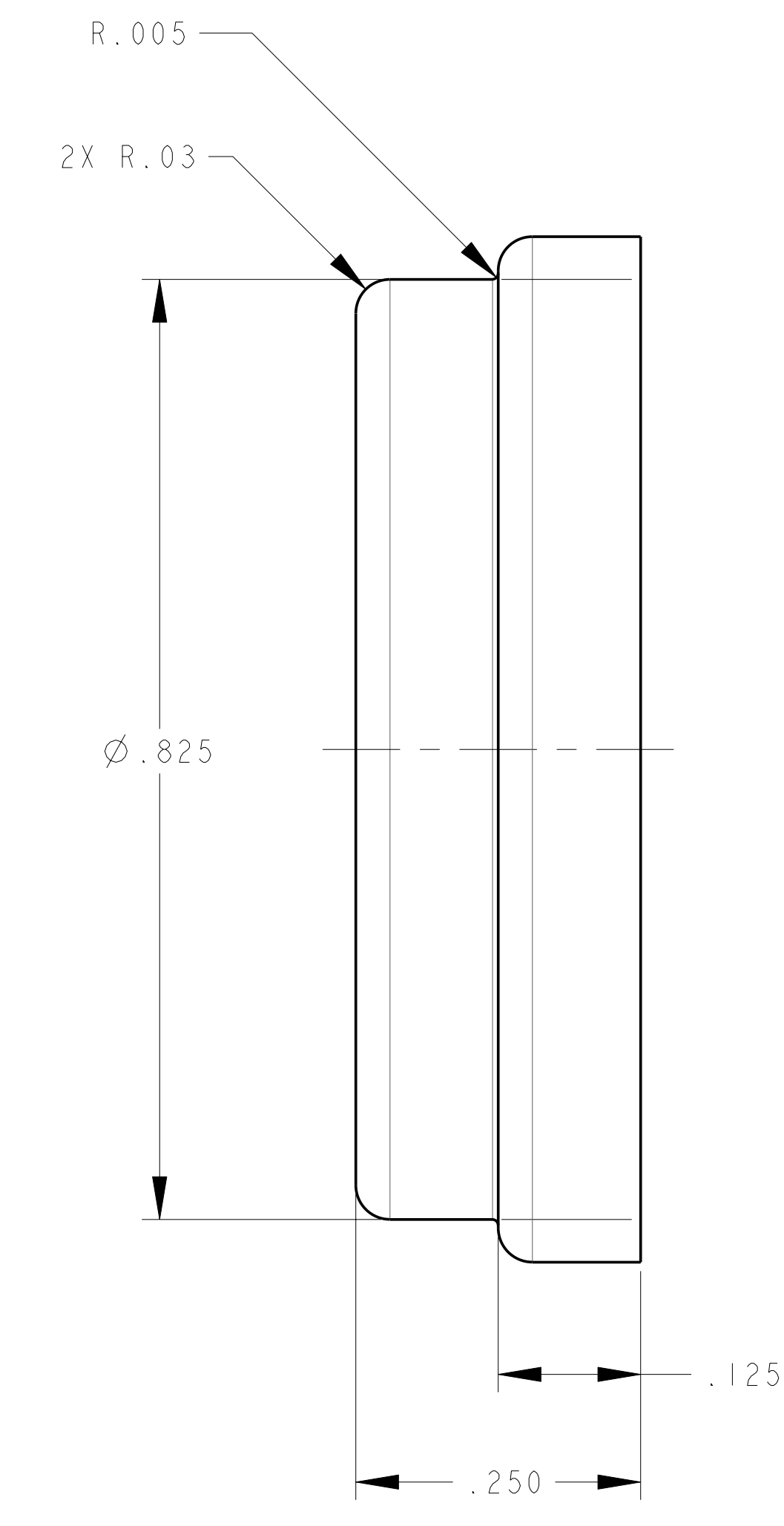
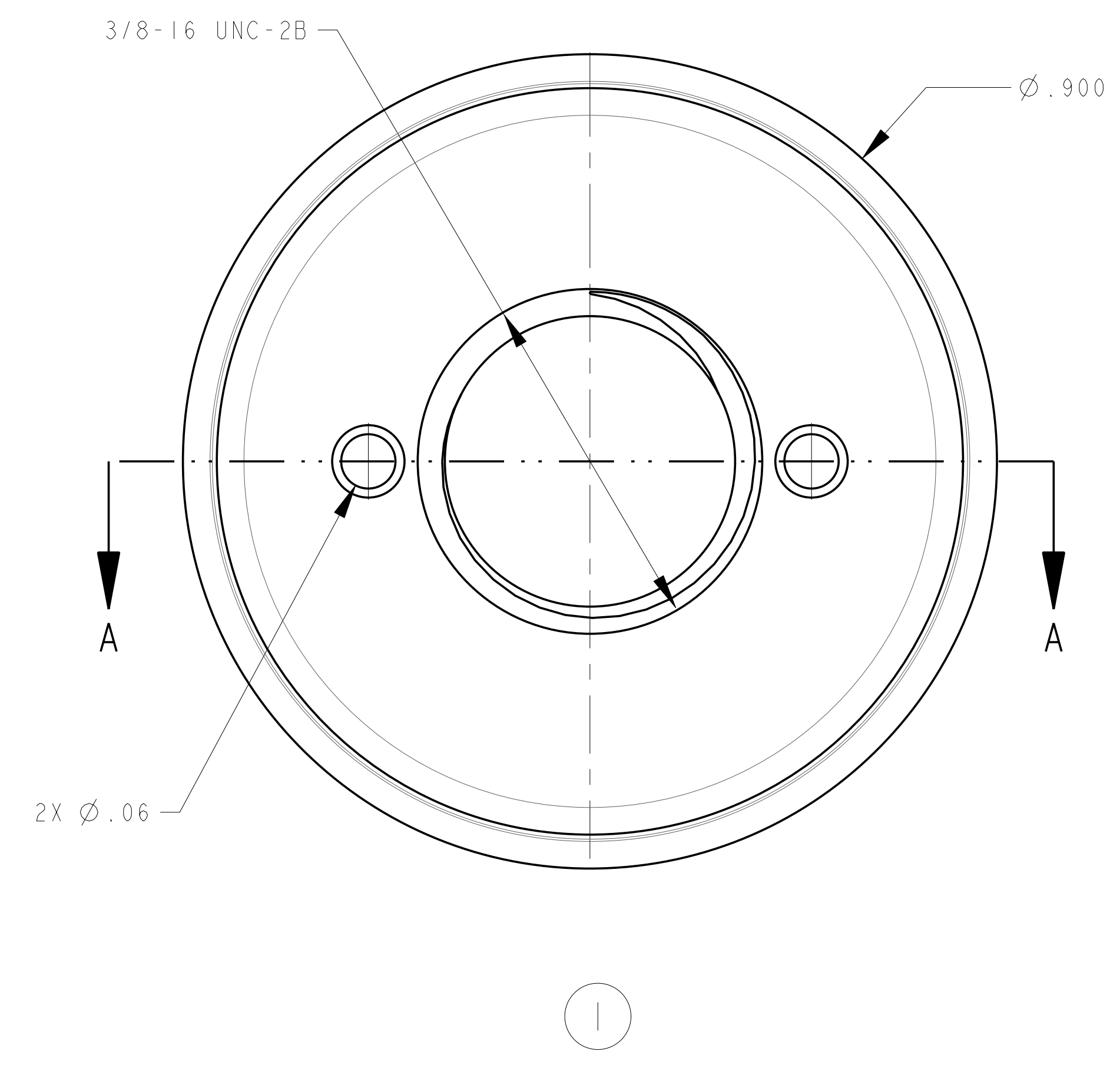
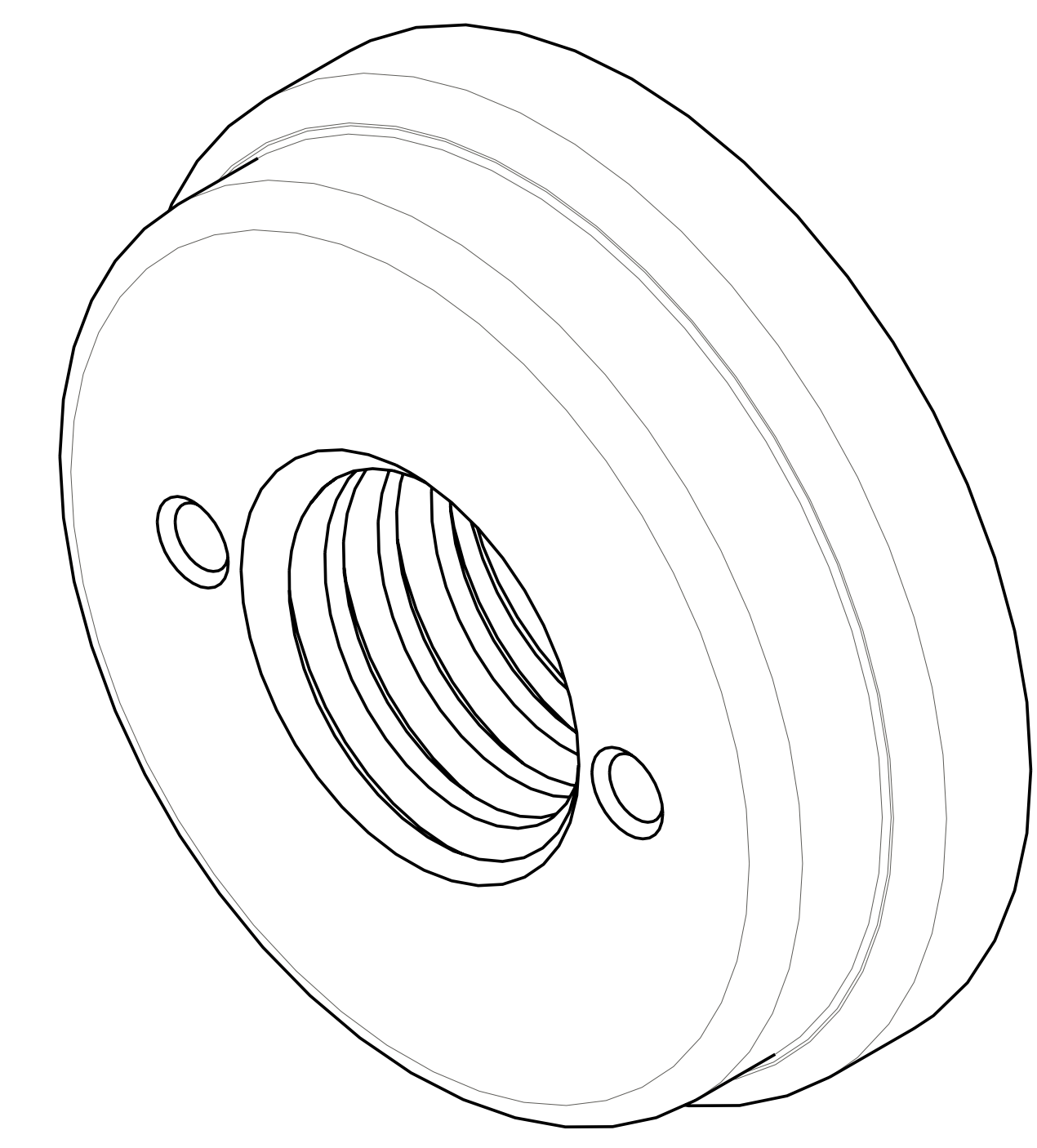
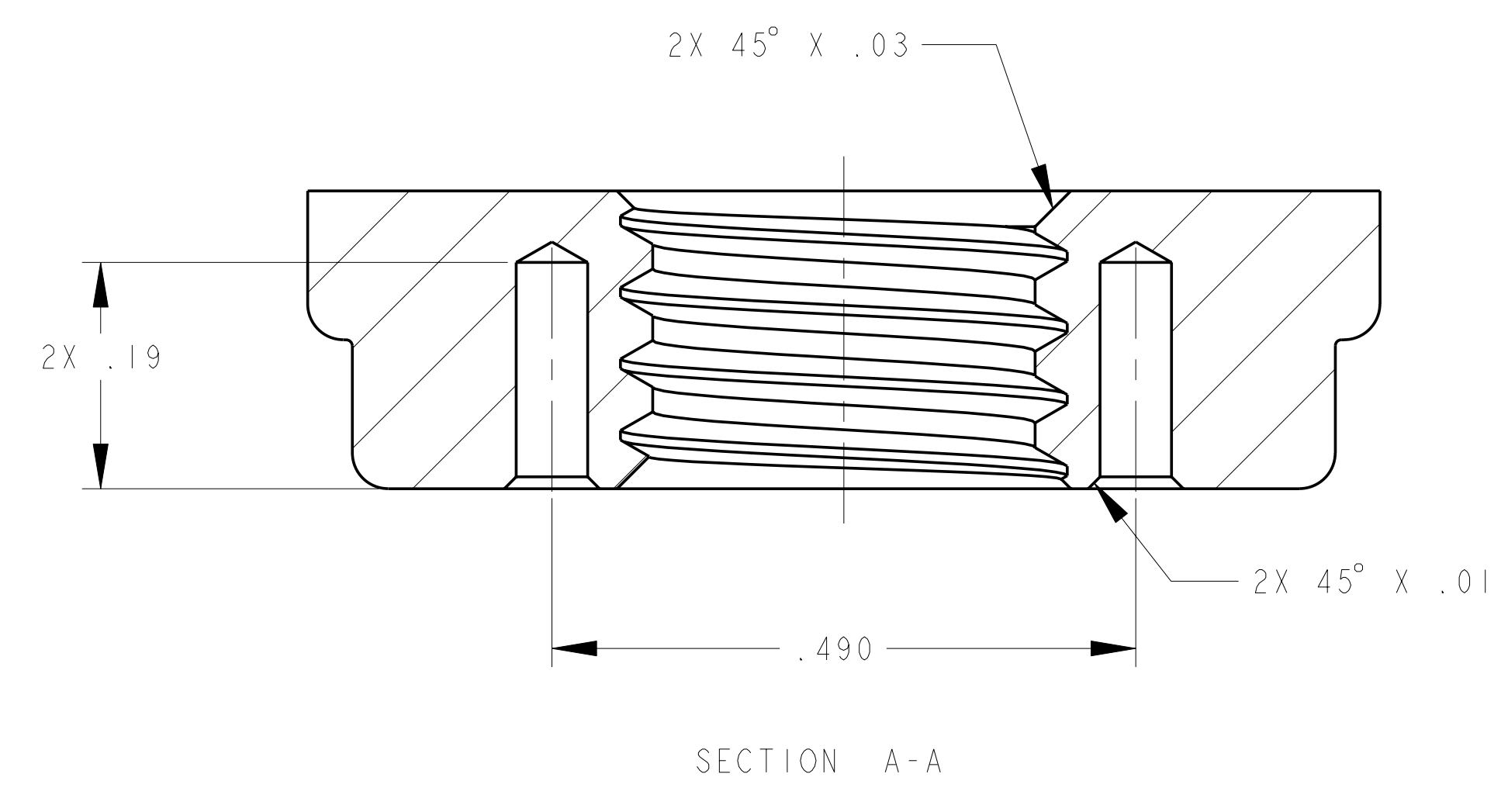

**RELEASED FOR FABRICATION / INSTALLATION**

AR	SEI405-260P	NUT, PIN DRIVE, 3/8-16 UNC-2B	316L SS AG PLATED	---	---
CAGE CODE	PART OR IDENTIFYING NO	NOMENCLATURE OR DESCRIPTION	MATERIAL	SPECIFICATION	FIND NO
SEI405-260					

← NEXT ASSEMBLY          PARTS LIST

NO REPRESENTATION OR WARRANTY, EXPRESSED OR IMPLIED, IS MADE AS TO THE ACCURACY, COMPLETENESS OR USEFULNESS OF THE INFORMATION OR STATEMENTS CONTAINED IN THESE DRAWINGS, OR THAT THE USE OR DISCLOSURE OF ANY INFORMATION, APPARATUS, METHOD OR PROCESS DISCLOSED IN THESE DRAWINGS MAY NOT INFRINGE PRIVATE RIGHTS OF OTHERS. NO LIABILITY IS ASSUMED WITH RESPECT TO THE USE OF, OR FOR DAMAGES RESULTING FROM THE USE OF, ANY INFORMATION, APPARATUS, METHOD OR PROCESS DISCLOSED IN THESE DRAWINGS. DRAWINGS MADE AVAILABLE FOR INFORMATION TO BIDDER ARE NOT TO BE USED FOR OTHER PURPOSES, AND ARE TO BE RETURNED UPON REQUEST OF THE FORWARDING CONTRACTOR.

**P** THIS DRAWING PRODUCED ON PRO-ENGINEER

REV	DESCRIPTION	BY	DATE	CHK	DEPT	DATE	PE	REG	DATE	DRNL	DOE	DATE	
REVISION OR ISSUE PURPOSE		REVISION APPROVAL						DRAWING APPROVALS					

SCALE	8	DES	PAUL MILLER	4-12-04
TOLERANCES UNLESS OTHERWISE SPECIFIED		DRW	PAUL MILLER	4-14-04
FRACTIONS	1/16	CHK		
XX DECIMALS	± .01	SECT		
XXX DECIMALS	± .005	DEPT		
ANGLES	± 0'15"	PE		
FINISH	.125 UNLESS OTHERWISE SPECIFIED	CR		
		PJ		
		RD		
		REO		
		PPPL DRFT		

**UT-BATTELLE**  
Oak Ridge National Laboratory  
 managed for the DEPARTMENT OF ENERGY under  
 U.S. GOVERNMENT contract DE-AC05-00OR22725  
 UT-BATTELLE, LLC, Oak Ridge, Tennessee  
 PROJECT NAME

**NATIONAL COMPACT STELLARATOR EXPERIMENT**

NUT, PIN DRIVE, 3/8-16 UNC-2B	
VERSION NO.	3
PLANT	X-10
BLDG	5700
FL	3
SHT OF	1
TYPE	S
CLASS	U
RELEASE LEVEL	WIP
REV	0

- NOTES:
1. INTERPRET DIMENSIONS AND TOLERANCES PER ANSI Y14.5M
  2. DIMENSIONS ARE IN INCHES
  3. DIMENSIONS APPLY AT ROOM TEMPERATURE. OPERATING TEMP 80 K
  4. GEOMETRY IS DEFINED IN PRO ENGINEER CAD MODELS/FILES
  5. DRAWING AND MODELS COMBINED DEFINE FINISHED MACHINED PART

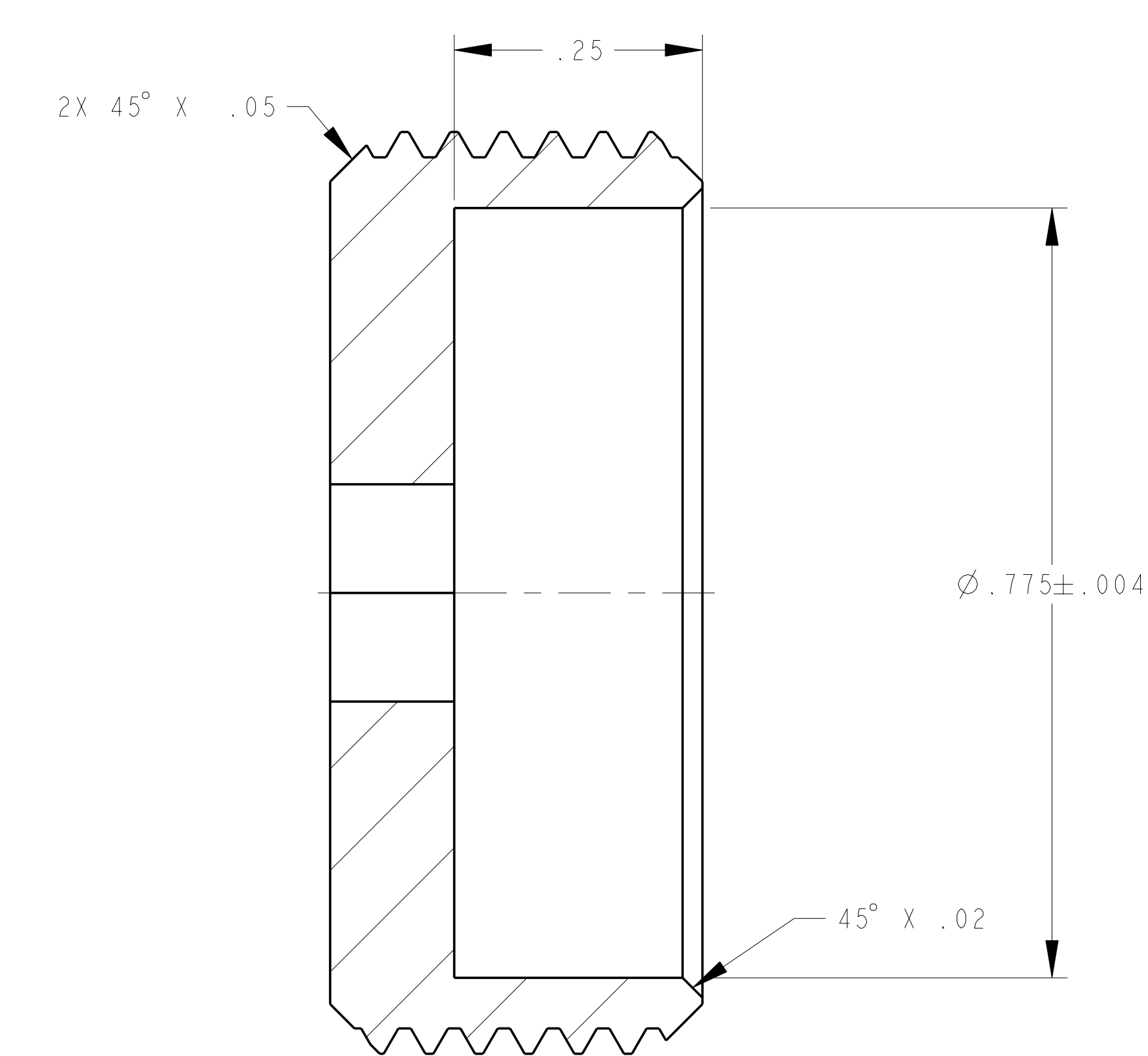
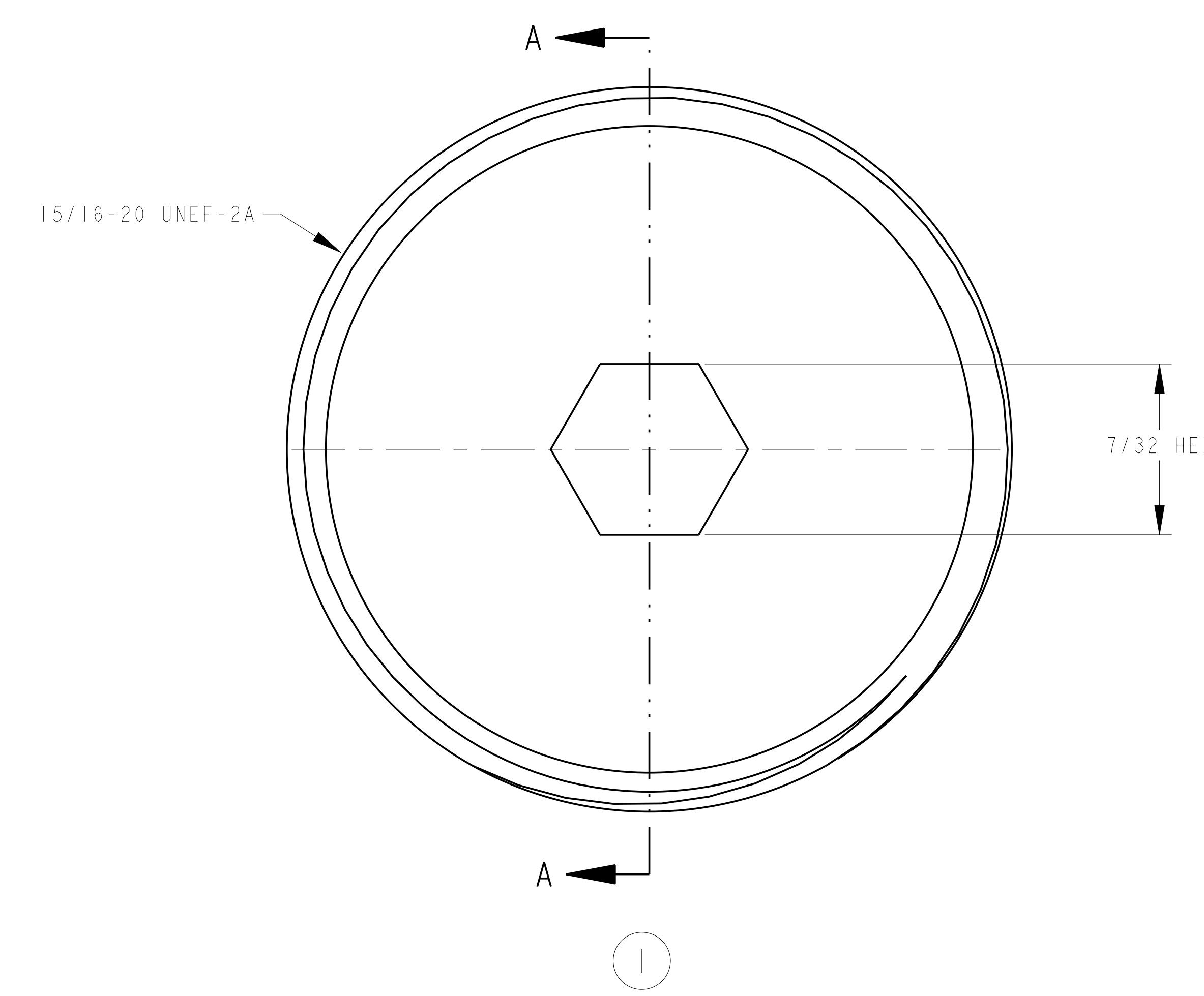
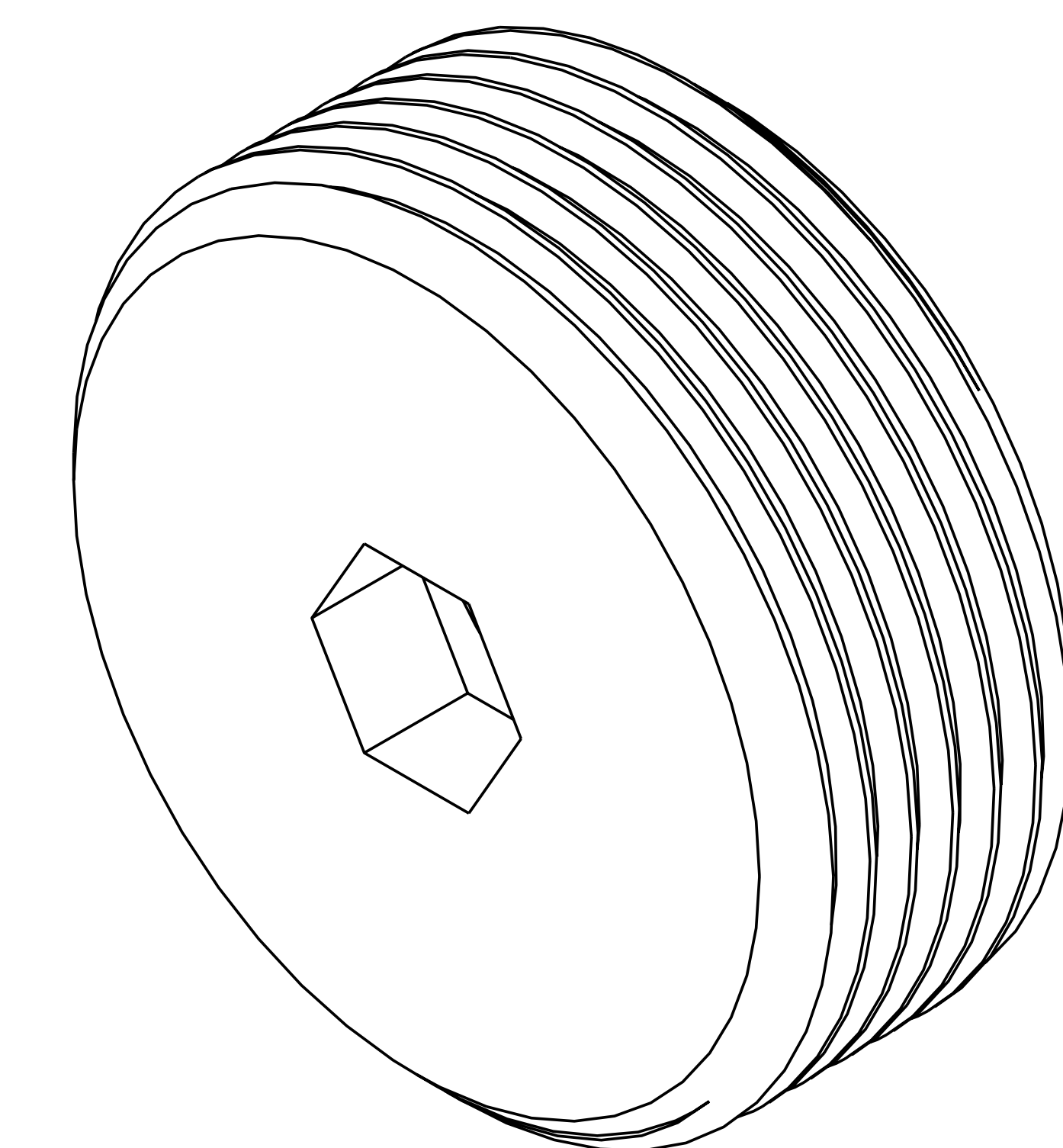
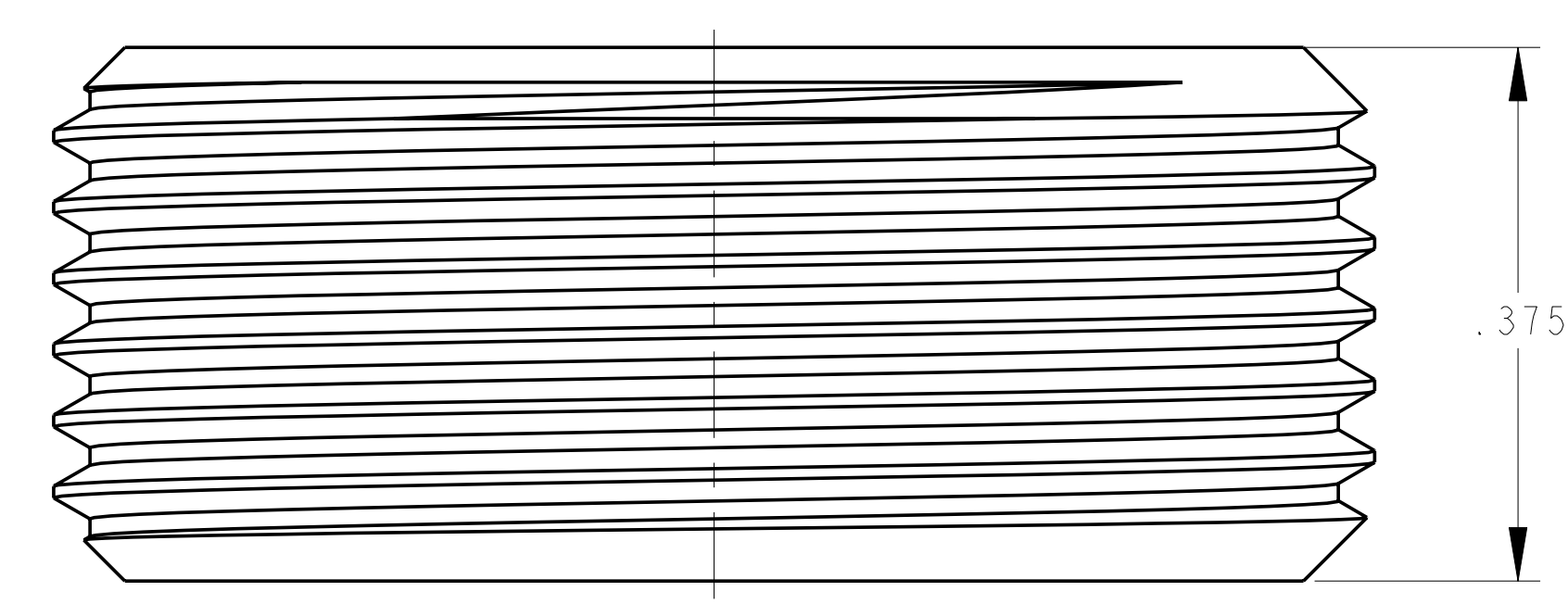

SECTION A-A

**RELEASED FOR FABRICATION / INSTALLATION**

AR	SEI405-261P	SCREW, SET, 15/16-20 UNEF-2A X 3/8	316L SS AG PLATED	--	1
CAGE CODE	PART OR IDENTIFYING NO	NOMENCLATURE OR DESCRIPTION	MATERIAL	SPECIFICATION	FIND NO
SEI405-250					

← NEXT ASSEMBLY

PARTS LIST

NO REPRESENTATION OR WARRANTY, EXPRESSED OR IMPLIED, IS MADE AS TO THE ACCURACY, COMPLETENESS OR USEFULNESS OF THE INFORMATION OR STATEMENTS CONTAINED IN THESE DRAWINGS, OR THAT THE USE OR DISCLOSURE OF ANY INFORMATION, APPARATUS, METHOD OR PROCESS DISCLOSED IN THESE DRAWINGS MAY NOT INFRINGE PRIVATE RIGHTS OF OTHERS. NO LIABILITY IS ASSUMED WITH RESPECT TO THE USE OF, OR FOR DAMAGES RESULTING FROM THE USE OF, ANY INFORMATION, APPARATUS, METHOD OR PROCESS DISCLOSED IN THESE DRAWINGS. DRAWINGS MADE AVAILABLE FOR INFORMATION TO BIDDER ARE NOT TO BE USED FOR OTHER PURPOSES, AND ARE TO BE RETURNED UPON REQUEST OF THE FORWARDING CONTRACTOR.

**P** THIS DRAWING PRODUCED ON PRO-ENGINEER

REV	DESCRIPTION	BY	DATE	CHK	DEPT	DATE	PE	REQ	DATE	DRNL	DOE	DATE

SCALE 8	DES PAUL MILLER 4-12-04	<b>UT-BATTELLE</b> Oak Ridge National Laboratory managed for the DEPARTMENT OF ENERGY under U.S. GOVERNMENT contract DE-AC05-00OR22725 UT-BATTELLE, LLC, Oak Ridge, Tennessee PROJECT NAME <b>NATIONAL COMPACT STELLARATOR EXPERIMENT</b>
TOLERANCES UNLESS OTHERWISE SPECIFIED	DRW PAUL MILLER 4-14-04	
FRACTIONS	CHK :	VERSION NO. 3 PLANT X-10 BLDG 5700 FL 3 SHT OF 1 TYPE I CLASS S U REV 0
XX DECIMALS ± .01	SECT :	
XXX DECIMALS ± .005	DEPT :	
ANGLES ± 0°15'	PE :	
BREAK SHARP EDGES 06 MAX	CR :	
FINISH .125 UNLESS OTHERWISE SPECIFIED	PJ :	
	RD :	
	PPPL DRFT :	
	REVISION APPROVALS	DATE

- NOTES:
1. INTERPRET DIMENSIONS AND TOLERANCES PER ANSI Y14.5M
  2. DIMENSIONS ARE IN INCHES
  3. DIMENSIONS APPLY AT ROOM TEMPERATURE. OPERATING TEMP 80 K
  4. GEOMETRY IS DEFINED IN PRO ENGINEER CAD MODELS/FILES
  5. DRAWING AND MODELS COMBINED DEFINE FINISHED MACHINED PART

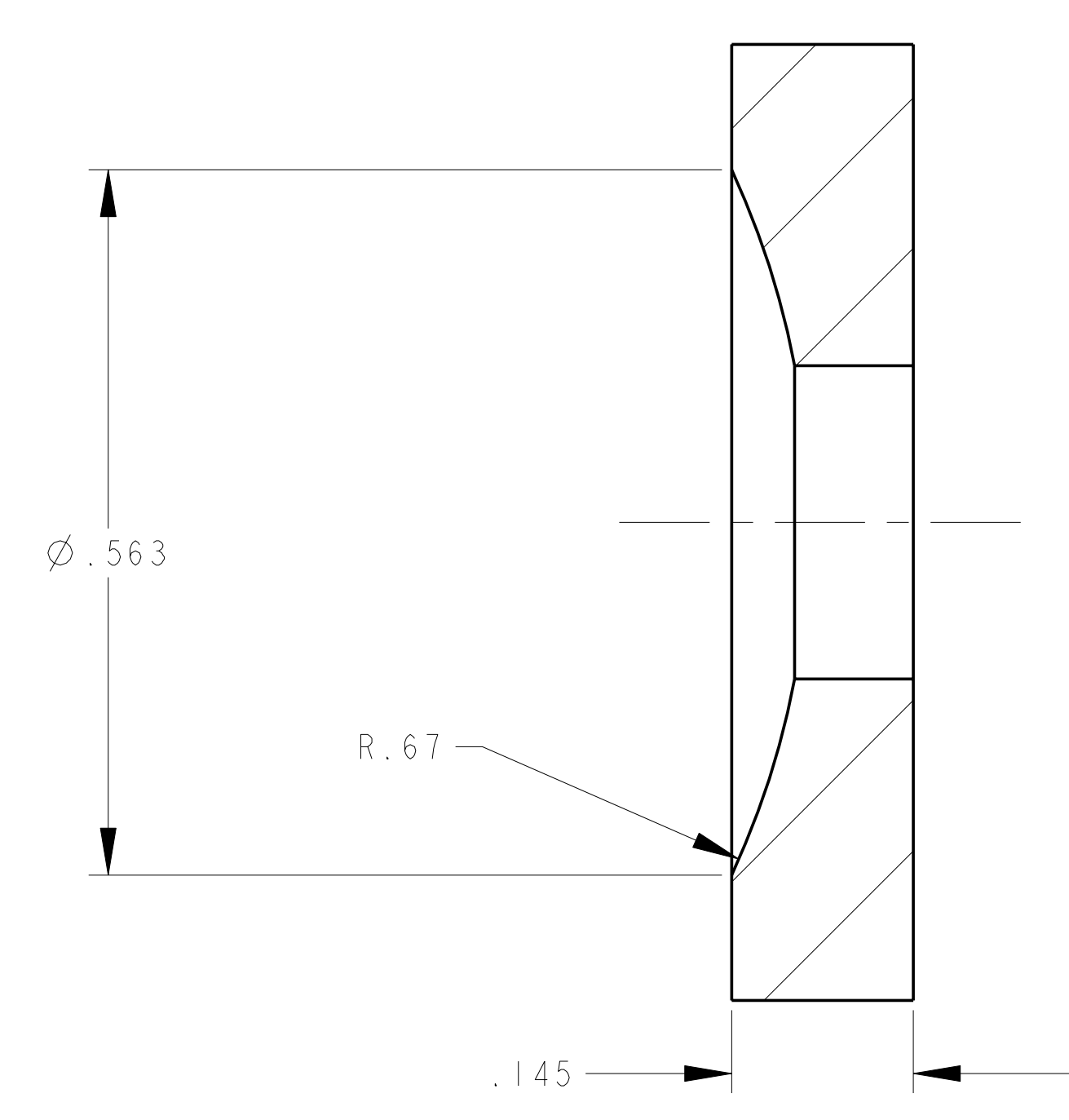
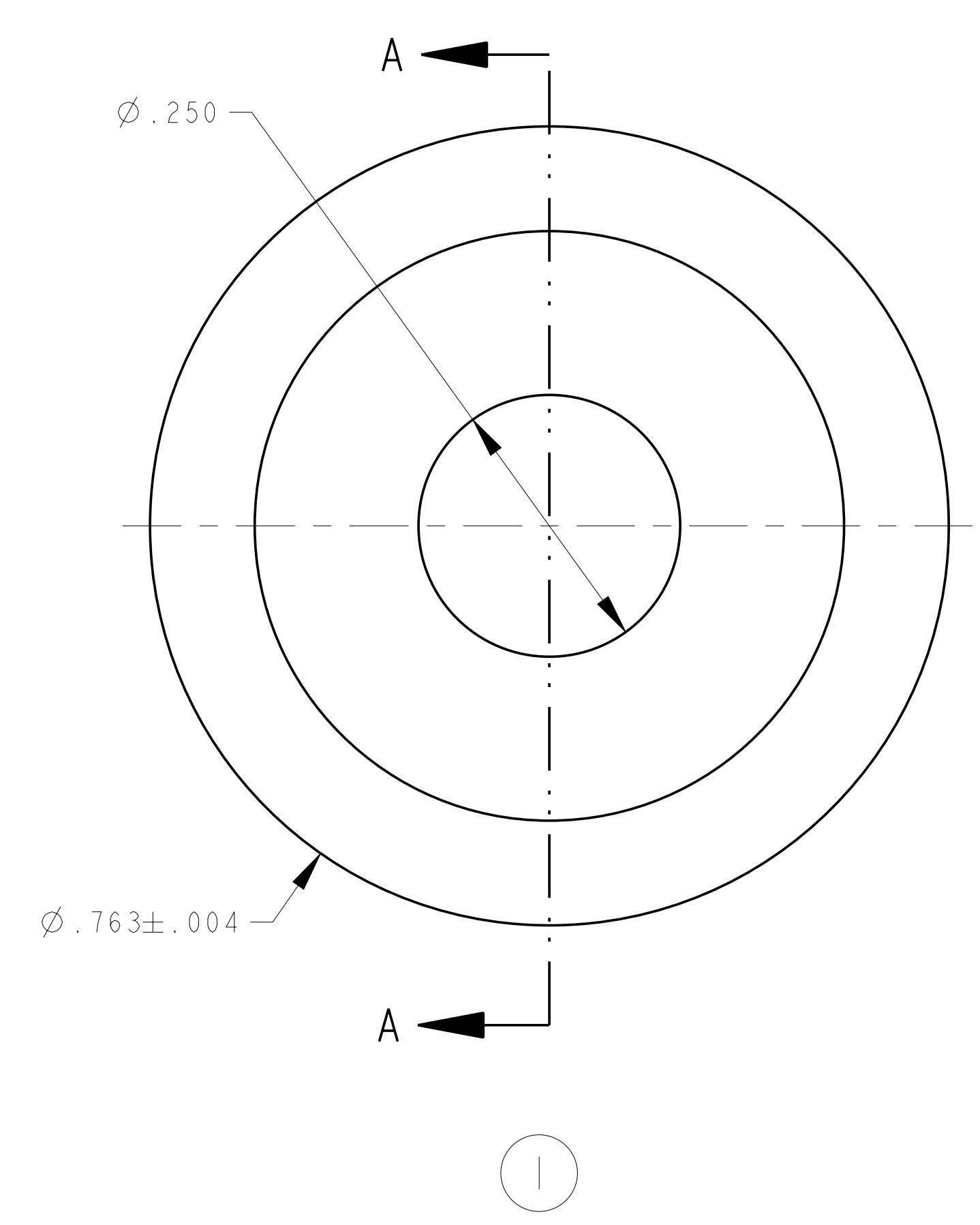

SECTION A-A

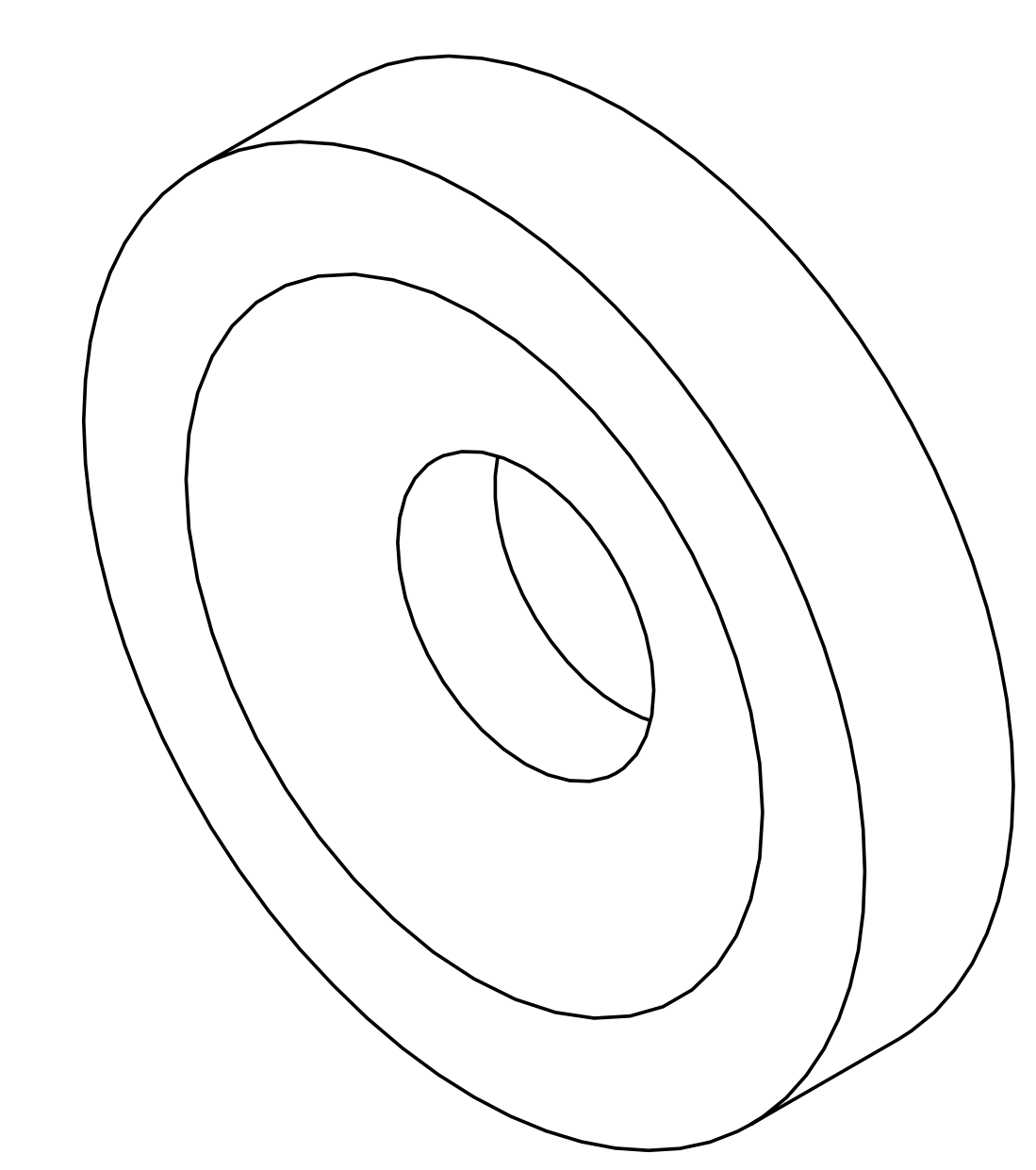

**RELEASED FOR FABRICATION / INSTALLATION**

AR	SEI405-262P	PISTON, SPHERICAL, CONCAVE	A286 SUPERALLOY	--	
SEI405-262P	PART OR IDENTIFYING NO	NOMENCLATURE OR DESCRIPTION	MATERIAL	SPECIFICATION	FIND NO
	← NEXT ASSEMBLY		PARTS LIST		

										SCALE 8	DES PAUL MILLER 4-12-04	Oak Ridge National Laboratory managed for the DEPARTMENT OF ENERGY under U.S. GOVERNMENT contract DE-AC05-00OR22725 UT-BATTELLE, LLC, Oak Ridge, Tennessee PROJECT NAME <b>NATIONAL COMPACT STELLARATOR EXPERIMENT</b>					
										TOLERANCES UNLESS OTHERWISE SPECIFIED	DRW PAUL MILLER 4-15-04	UT-BATTELLE PISTON, SPHERICAL, CONCAVE					
										FRACTIONS	CHK :	PPPL DRFT : VERSION NO. 3 PLANT X-10 BLDG 5700 FL 3 SHT OF 1 TYPE 1 CLASS S U					
										XX DECIMALS ± .01	SECT :	RELEASE LEVEL Fabrication					
										XXX DECIMALS ± .005	DEPT :	SEI405-262P					
										ANGLES ± 0°15'	PE :						
										BREAK SHARP EDGES .06 MAX	CR :						
										FINISH .125 UNLESS OTHERWISE SPECIFIED	PJ :						
											RD :						
REV	DESCRIPTION	BY	DATE	CHK	DEPT	DATE	PE	REQ	DATE	DRNL	DOE	DATE	DRAWING APPROVALS			DATE	
	REVISION OR ISSUE PURPOSE																

NO REPRESENTATION OR WARRANTY, EXPRESSED OR IMPLIED, IS MADE AS TO THE ACCURACY, COMPLETENESS OR USEFULNESS OF THE INFORMATION OR STATEMENTS CONTAINED IN THESE DRAWINGS, OR THAT THE USE OR DISCLOSURE OF ANY INFORMATION, APPARATUS, METHOD OR PROCESS DISCLOSED IN THESE DRAWINGS MAY NOT INFRINGE PRIVATE RIGHTS OF OTHERS. NO LIABILITY IS ASSUMED WITH RESPECT TO THE USE OF, OR FOR DAMAGES RESULTING FROM THE USE OF, ANY INFORMATION, APPARATUS, METHOD OR PROCESS DISCLOSED IN THESE DRAWINGS. DRAWINGS MADE AVAILABLE FOR INFORMATION TO BIDDER ARE NOT TO BE USED FOR OTHER PURPOSES, AND ARE TO BE RETURNED UPON REQUEST OF THE FORWARDING CONTRACTOR.

**P** THIS DRAWING PRODUCED ON PRO-ENGINEER

H  
G  
F  
E  
D  
C  
B  
A

SEI405-262P

- NOTES:
1. INTERPRET DIMENSIONS AND TOLERANCES PER ANSI Y14.5M
  2. DIMENSIONS ARE IN INCHES
  3. DIMENSIONS APPLY AT ROOM TEMPERATURE. OPERATING TEMP 80 K
  4. GEOMETRY IS DEFINED IN PRO ENGINEER CAD MODELS/FILES
  5. DRAWING AND MODELS COMBINED DEFINE FINISHED MACHINED PART

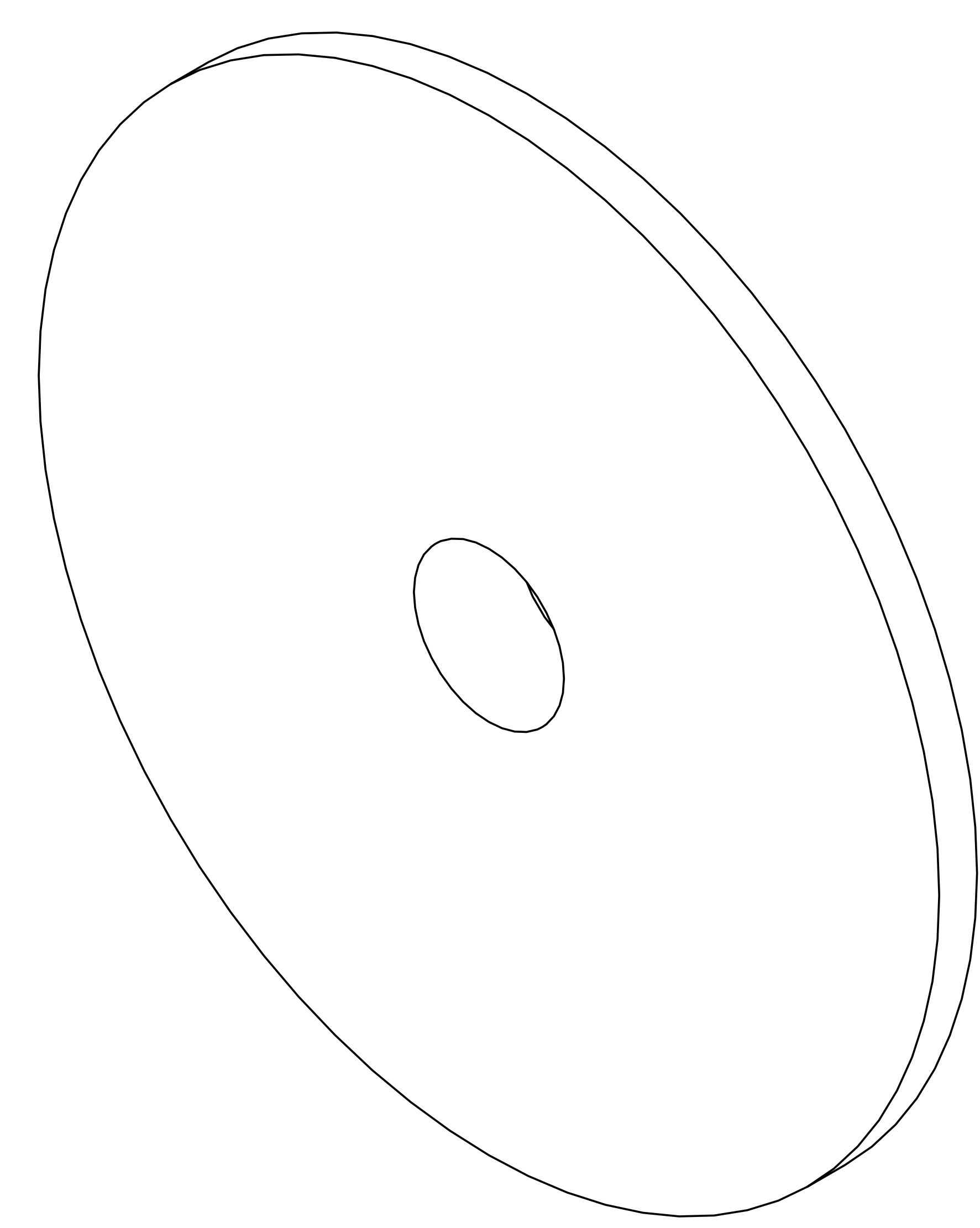
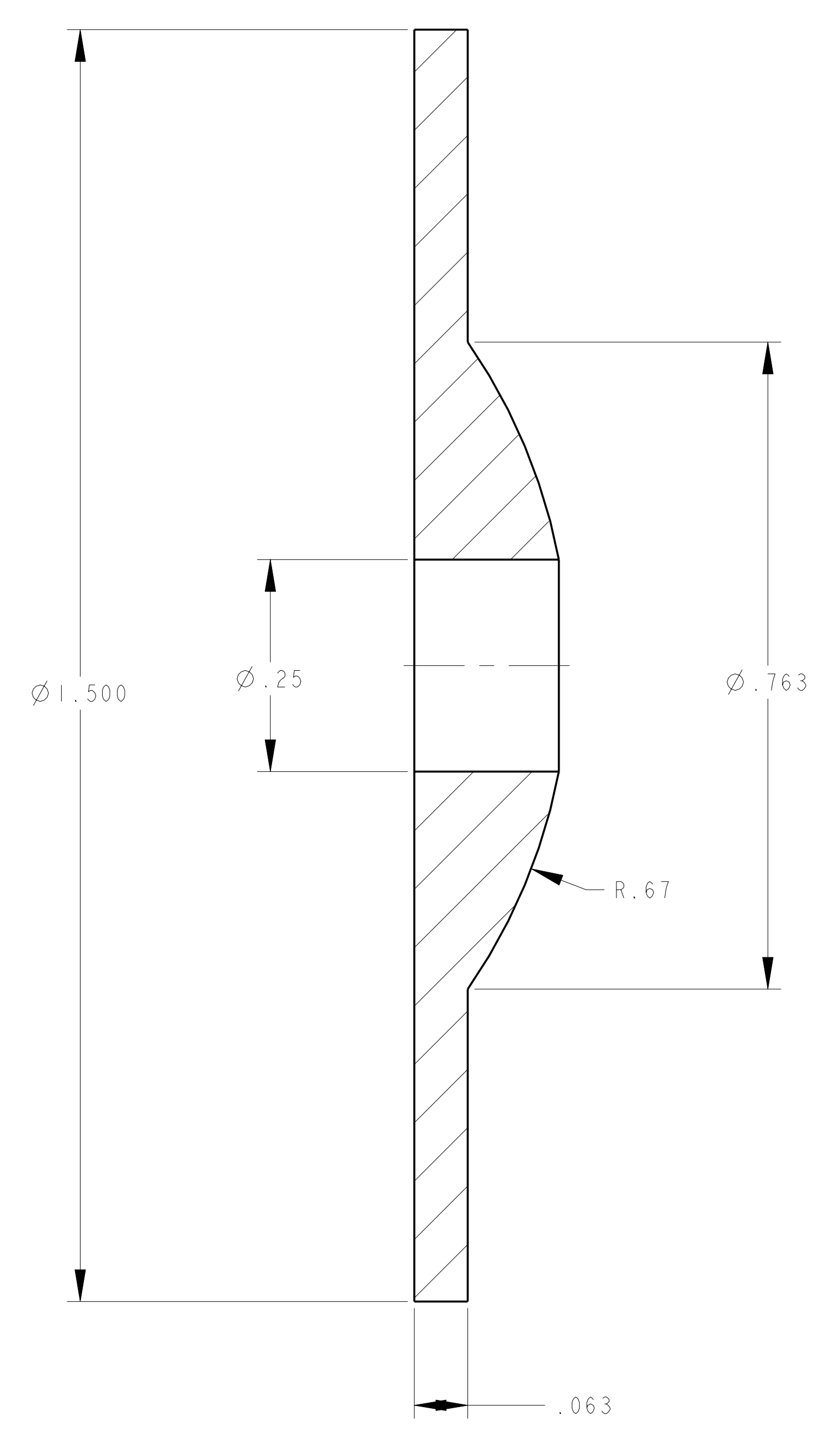
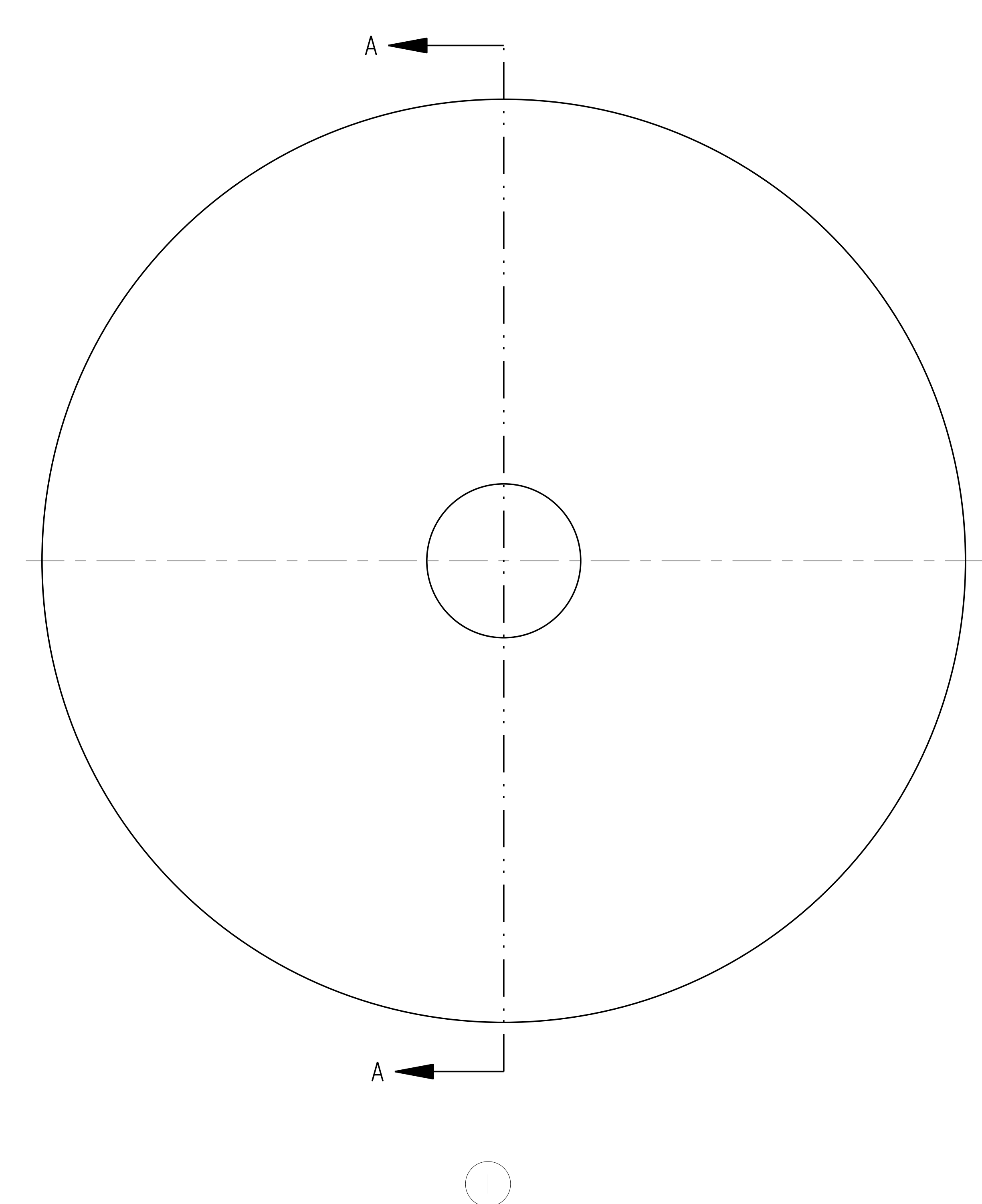

**RELEASED FOR FABRICATION / INSTALLATION**

SECTION A-A

AR	SEI405-263P	WASHER, SPERICAL, CONVEX	316L SS	--	1
CAGE CODE	PART OR IDENTIFYING NO	NOMENCLATURE OR DESCRIPTION	MATERIAL	SPECIFICATION	FIND NO
SEI405-263	← NEXT ASSEMBLY	PARTS LIST			

NO REPRESENTATION OR WARRANTY, EXPRESSED OR IMPLIED, IS MADE AS TO THE ACCURACY, COMPLETENESS OR USEFULNESS OF THE INFORMATION OR STATEMENTS CONTAINED IN THESE DRAWINGS, OR THAT THE USE OR DISCLOSURE OF ANY INFORMATION, APPARATUS, METHOD OR PROCESS DISCLOSED IN THESE DRAWINGS MAY NOT INFRINGE PRIVATE RIGHTS OF OTHERS. NO LIABILITY IS ASSUMED WITH RESPECT TO THE USE OF, OR FOR DAMAGES RESULTING FROM THE USE OF, ANY INFORMATION, APPARATUS, METHOD OR PROCESS DISCLOSED IN THESE DRAWINGS. DRAWINGS MADE AVAILABLE FOR INFORMATION TO BIDDER ARE NOT TO BE USED FOR OTHER PURPOSES, AND ARE TO BE RETURNED UPON REQUEST OF THE FORWARDING CONTRACTOR.

**P** THIS DRAWING PRODUCED ON PRO-ENGINEER

REV	DESCRIPTION	BY	DATE	CHK	DEPT	DATE	PE	REQ	DATE	ORNL	DOE	DATE
REVISION OR ISSUE PURPOSE							REVISION APPROVAL					

SCALE	8
TOLERANCES UNLESS OTHERWISE SPECIFIED	
FRACTIONS	
XX DECIMALS	± .01
XXX DECIMALS	± .005
ANGLES	± 0'15"
BREAK SHARP EDGES	06 MAX
FINISH	AS UNLESS OTHERWISE SPECIFIED
DES	PAUL MILLER 4-12-04
DRW	PAUL MILLER 4-15-04
CHK	:
SECT	:
DEPT	:
PE	:
CR	:
PJ	:
RED	:
PPPL DRFT	:
VERSION NO.	3
PLANT	X-10
BLDG	5700
FL	3
SHT OF	1
TYPE	I S
CLASS	U
RELEASE LEVEL	Fabrication
DRAWING APPROVALS	DATE

Oak Ridge National Laboratory managed for the DEPARTMENT OF ENERGY under U.S. GOVERNMENT contract DE-AC05-00OR22725 UT-BATTELLE, LLC, Oak Ridge, Tennessee  
**UT-BATTELLE**  
 NATIONAL COMPACT STELLARATOR EXPERIMENT  
 WASHER, SPERICAL, CONVEX  
 SEI405-263P  
 REV 0

- NOTES:
1. INTERPRET DIMENSIONS AND TOLERANCES PER ANSI Y14.5M
  2. DIMENSIONS ARE IN INCHES
  3. DIMENSIONS APPLY AT ROOM TEMPERATURE. OPERATING TEMP 80 K
  4. GEOMETRY IS DEFINED IN PRO ENGINEER CAD MODELS/FILES
  5. DRAWING AND MODELS COMBINED DEFINE FINISHED MACHINED PART

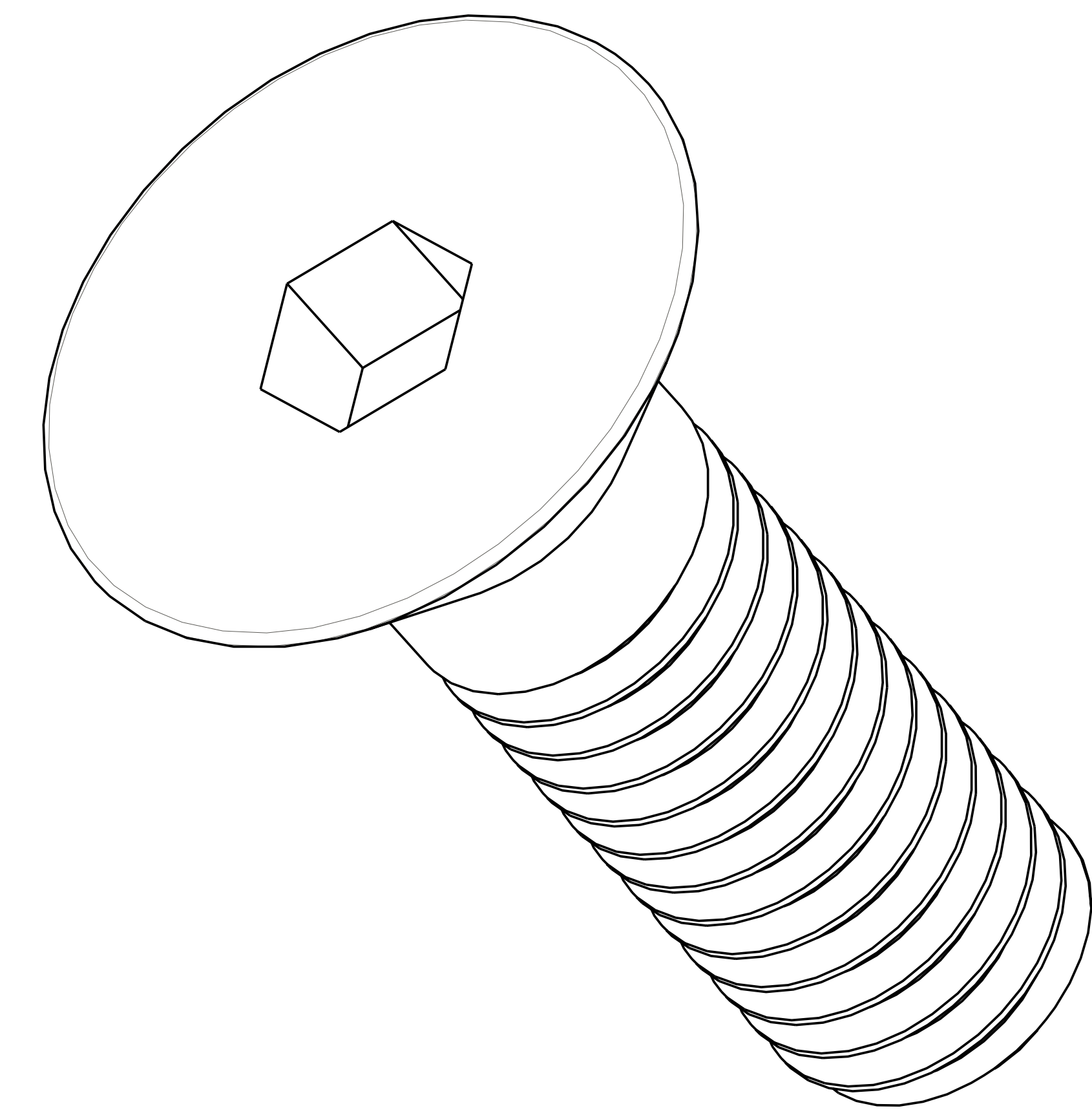
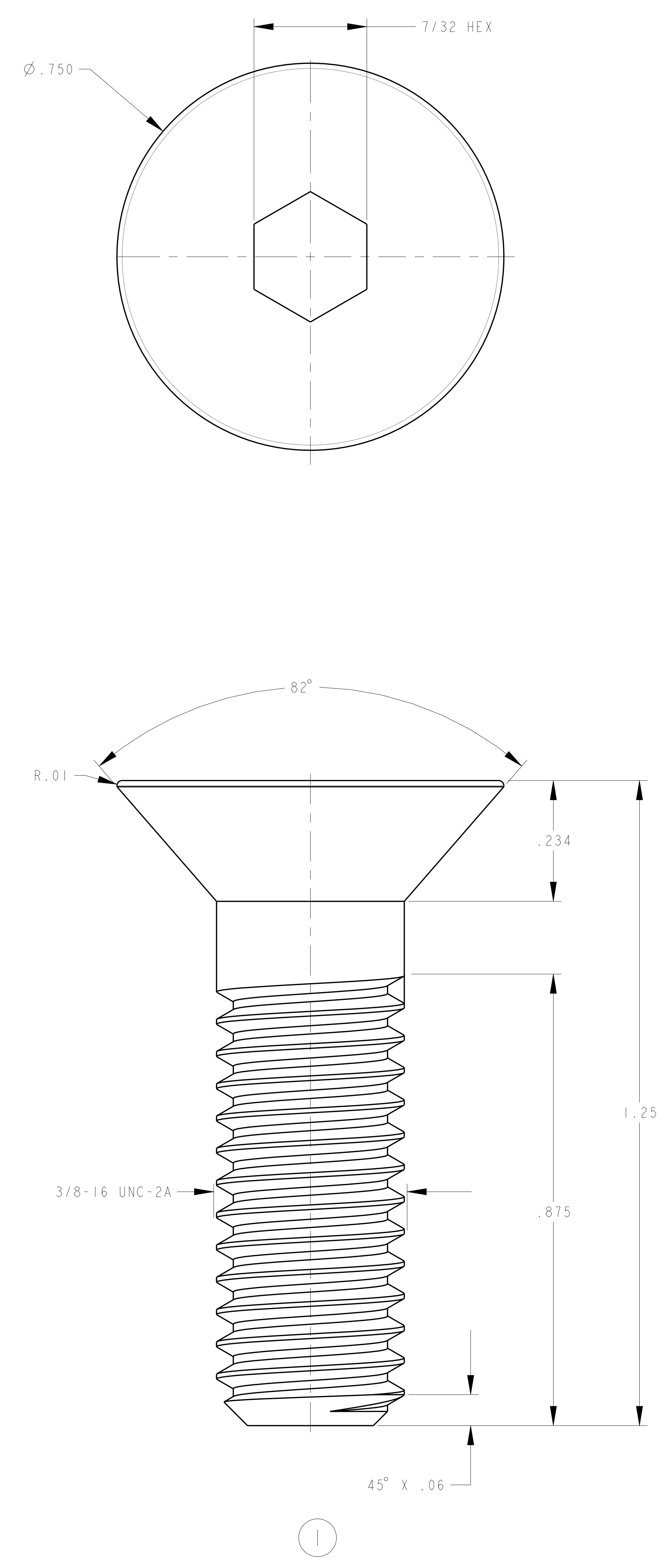

**RELEASED FOR  
FABRICATION / INSTALLATION**

AR	SEI405-264P	SCREW, 3/8-16 UNC-2A X 1 1/4	316L SS AG PLATED	--	1
CAGE CODE	PART OR IDENTIFYING NO	NOMENCLATURE OR DESCRIPTION	MATERIAL	SPECIFICATION	FIND NO
SEI405-250					

← NEXT ASSEMBLY

PARTS LIST

NO REPRESENTATION OR WARRANTY, EXPRESSED OR IMPLIED, IS MADE AS TO THE ACCURACY, COMPLETENESS OR USEFULNESS OF THE INFORMATION OR STATEMENTS CONTAINED IN THESE DRAWINGS, OR THAT THE USE OR DISCLOSURE OF ANY INFORMATION, APPARATUS, METHOD OR PROCESS DISCLOSED IN THESE DRAWINGS MAY NOT INFRINGE PRIVATE RIGHTS OF OTHERS. NO LIABILITY IS ASSUMED WITH RESPECT TO THE USE OF, OR FOR DAMAGES RESULTING FROM THE USE OF, ANY INFORMATION, APPARATUS, METHOD OR PROCESS DISCLOSED IN THESE DRAWINGS. DRAWINGS MADE AVAILABLE FOR INFORMATION TO BIDDER ARE NOT TO BE USED FOR OTHER PURPOSES, AND ARE TO BE RETURNED UPON REQUEST OF THE FORWARDING CONTRACTOR.

**P** THIS DRAWING PRODUCED ON PRO-ENGINEER

REV	DESCRIPTION	BY	DATE	CHK	DEPT	DATE	PE	REQ	DATE	ORNL	DOE	DATE

SCALE	8	DES	PAUL MILLER	4-12-04	<b>UT-BATTELLE</b> Oak Ridge National Laboratory managed for the DEPARTMENT OF ENERGY under U.S. GOVERNMENT contract DE-AC05-00OR22725 UT-BATTELLE, LLC, Oak Ridge, Tennessee PROJECT NAME <b>NATIONAL COMPACT STELLARATOR EXPERIMENT</b> SCREW, 3/8-16 UNC-2A X 1 1/4 HEX SOCKET FLAT COUNTERSUNK HEAD CAP											
TOLERANCES UNLESS OTHERWISE SPECIFIED		DRW	PAUL MILLER	4-14-04												
FRACTIONS		CHK														
XX DECIMALS ± .01		SECT														
XXX DECIMALS ± .005		DEPT														
ANGLES ± 0°15'		PE														
BREAK SHARP EDGES .06 MAX		CR														
FINISH .125 UNLESS OTHERWISE SPECIFIED		PJ														
		RD														
		PPPL DRFT														
		VERSION NO.	3	PLANT	X-10	BLDG	5700	FL	3	SHT OF	1	TYPE	I	CLASS	U	
		RELEASE LEVEL	WIP												REV	0
		DRAWING APPROVALS		DATE												

H  
G  
F  
E  
D  
C  
B  
A

8

7

6

5

4

3

2

1

NEXT ASS'Y: FINAL ASS'Y:

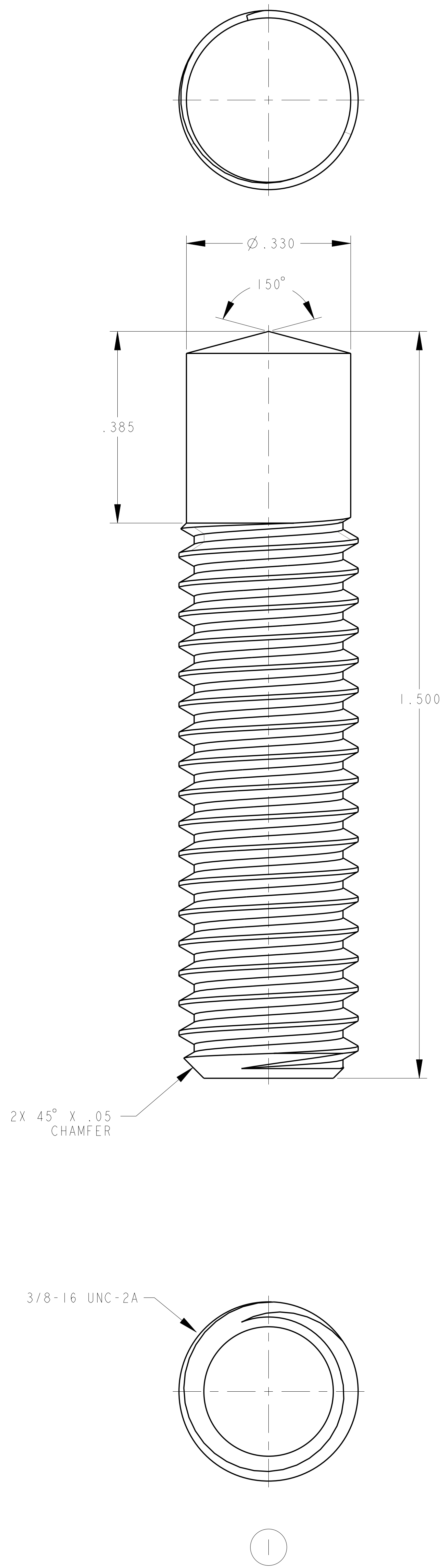

- NOTES:
1. INTERPRET DIMENSIONS AND TOLERANCES PER ANSI Y14.5M
  2. DIMENSIONS ARE IN INCHES
  3. DIMENSIONS APPLY AT ROOM TEMPERATURE. OPERATING TEMP 80 K
  4. GEOMETRY IS DEFINED IN PRO ENGINEER CAD MODELS/FILES
  5. DRAWING AND MODELS COMBINED DEFINE FINISHED MACHINED PART

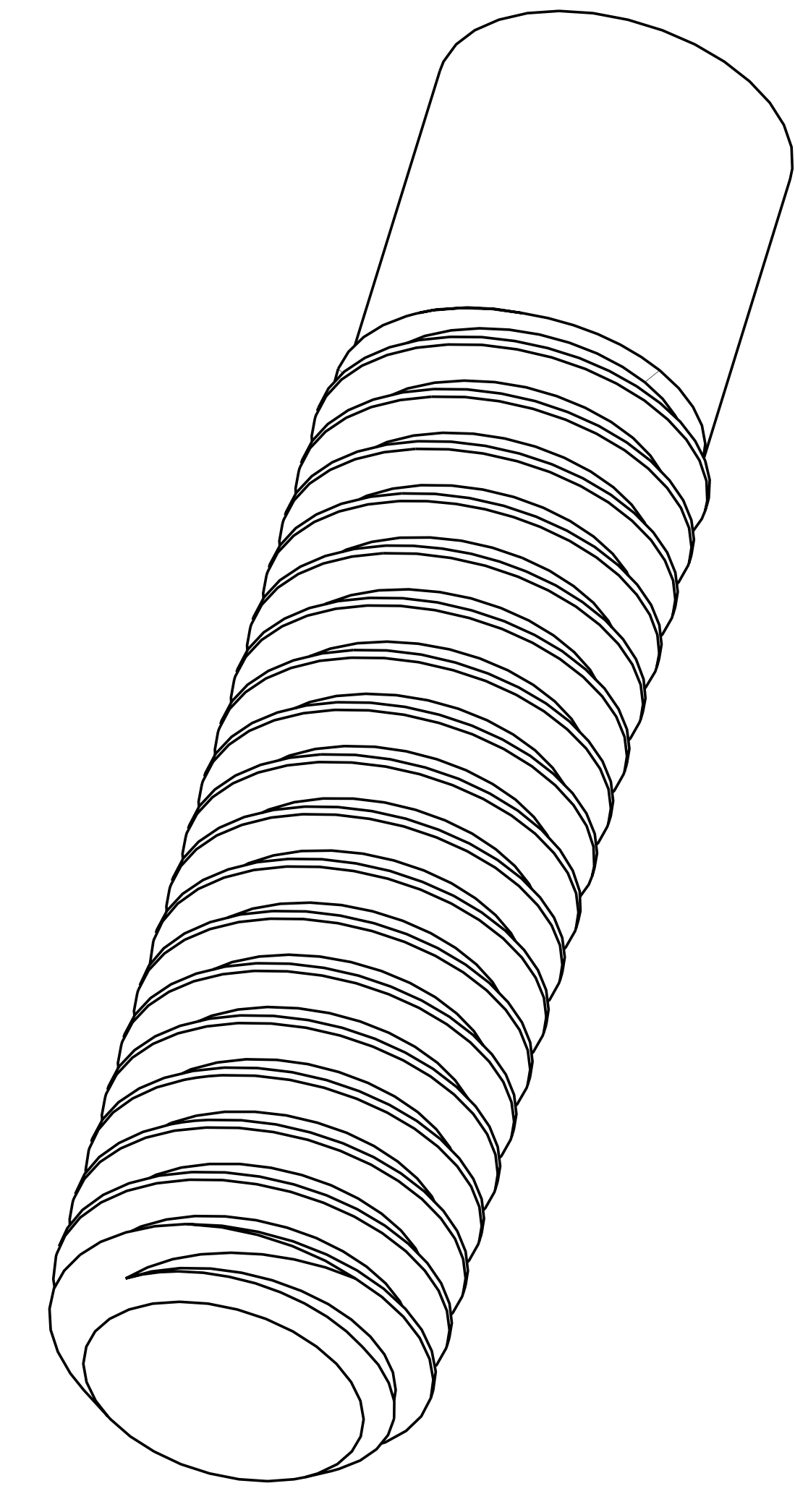

**RELEASED FOR FABRICATION / INSTALLATION**

AR	SE1405-265P	STUD, WELD, 3/8-16 UNC-2A	316L SS	--	1
SE1405-265	CAGE CODE	PART OR IDENTIFYING NO	NOMENCLATURE OR DESCRIPTION	MATERIAL	SPECIFICATION
	← NEXT ASSEMBLY			PARTS LIST	

NO REPRESENTATION OR WARRANTY, EXPRESSED OR IMPLIED, IS MADE AS TO THE ACCURACY, COMPLETENESS OR USEFULNESS OF THE INFORMATION OR STATEMENTS CONTAINED IN THESE DRAWINGS, OR THAT THE USE OR DISCLOSURE OF ANY INFORMATION, APPARATUS, METHOD OR PROCESS DISCLOSED IN THESE DRAWINGS MAY NOT INFRINGE PRIVATE RIGHTS OF OTHERS. NO LIABILITY IS ASSUMED WITH RESPECT TO THE USE OF, OR FOR DAMAGES RESULTING FROM THE USE OF, ANY INFORMATION, APPARATUS, METHOD OR PROCESS DISCLOSED IN THESE DRAWINGS. DRAWINGS MADE AVAILABLE FOR INFORMATION TO BIDDER ARE NOT TO BE USED FOR OTHER PURPOSES, AND ARE TO BE RETURNED UPON REQUEST OF THE FORWARDING CONTRACTOR.

**P** THIS DRAWING PRODUCED ON PRO-ENGINEER

REV	DESCRIPTION	BY	DATE	CHK	DEPT	DATE	PE	REQ	DATE	ORNL	DOE	DATE
	REVISION OR ISSUE PURPOSE											

SCALE	8	DES	PAUL MILLER	4-12-04	<b>UT-BATTELLE</b> Oak Ridge National Laboratory managed for the DEPARTMENT OF ENERGY under U.S. GOVERNMENT contract DE-AC05-00OR22725 UT-BATTELLE, LLC. Oak Ridge, Tennessee PROJECT NAME <b>NATIONAL COMPACT STELLARATOR EXPERIMENT</b>
TOLERANCES UNLESS OTHERWISE SPECIFIED		DRW	PAUL MILLER	4-14-04	
FRACTIONS		CHK			
XX DECIMALS ± .01		SECT			
XXX DECIMALS ± .005		DEPT			
ANGLES ± 0°15'		PE			
BREAK SHARP EDGES 06 MAX		CR			
FINISH .125 UNLESS OTHERWISE SPECIFIED		PJ			
		RED			
		PPPL DRFT			

VERSION NO.	PLANT	BLDG	FL	SHT OF	TYPE	CLASS
3	X-10	5700	3	1	U	S
RELEASE LEVEL	SE1405-265P			REV	0	
WIP						

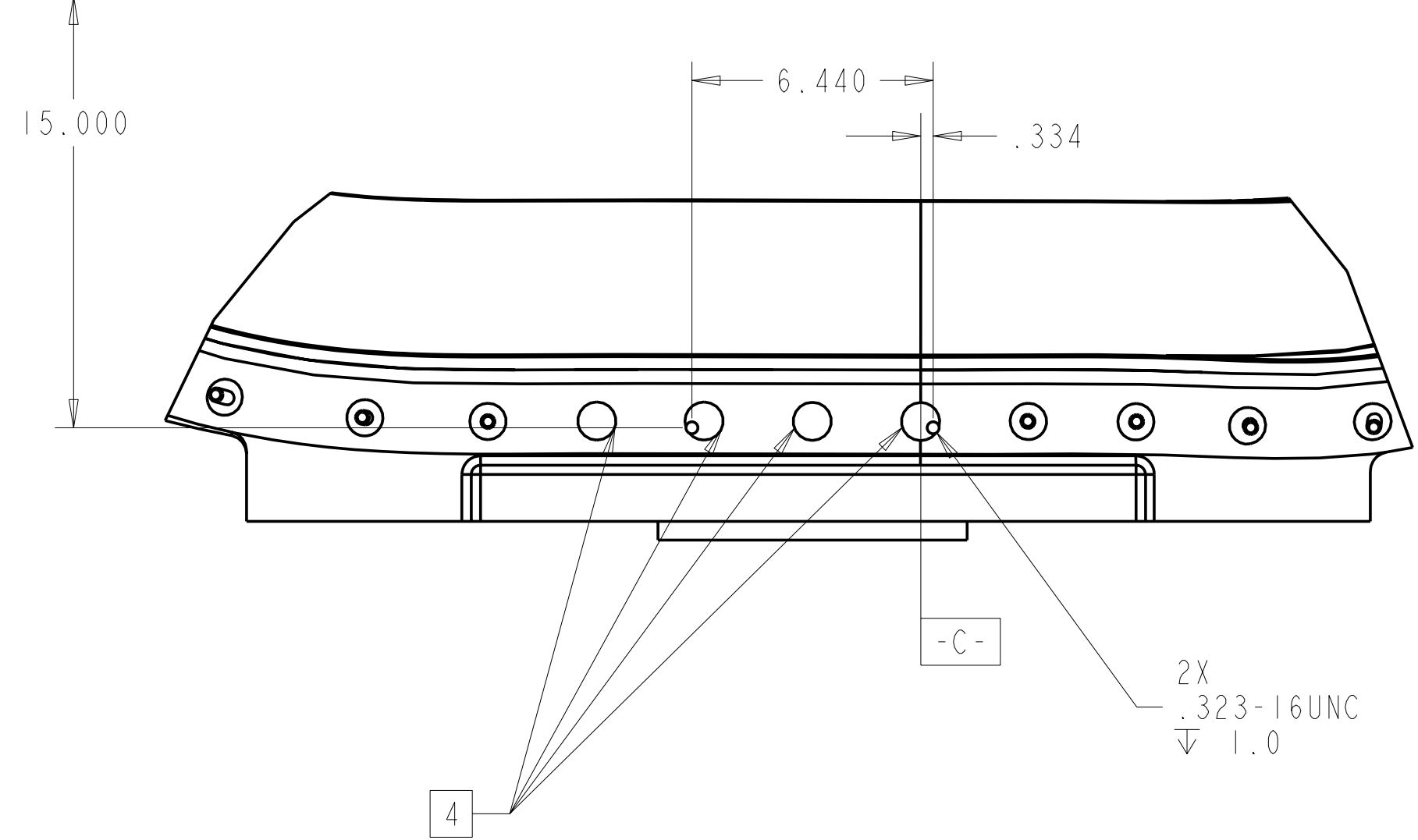
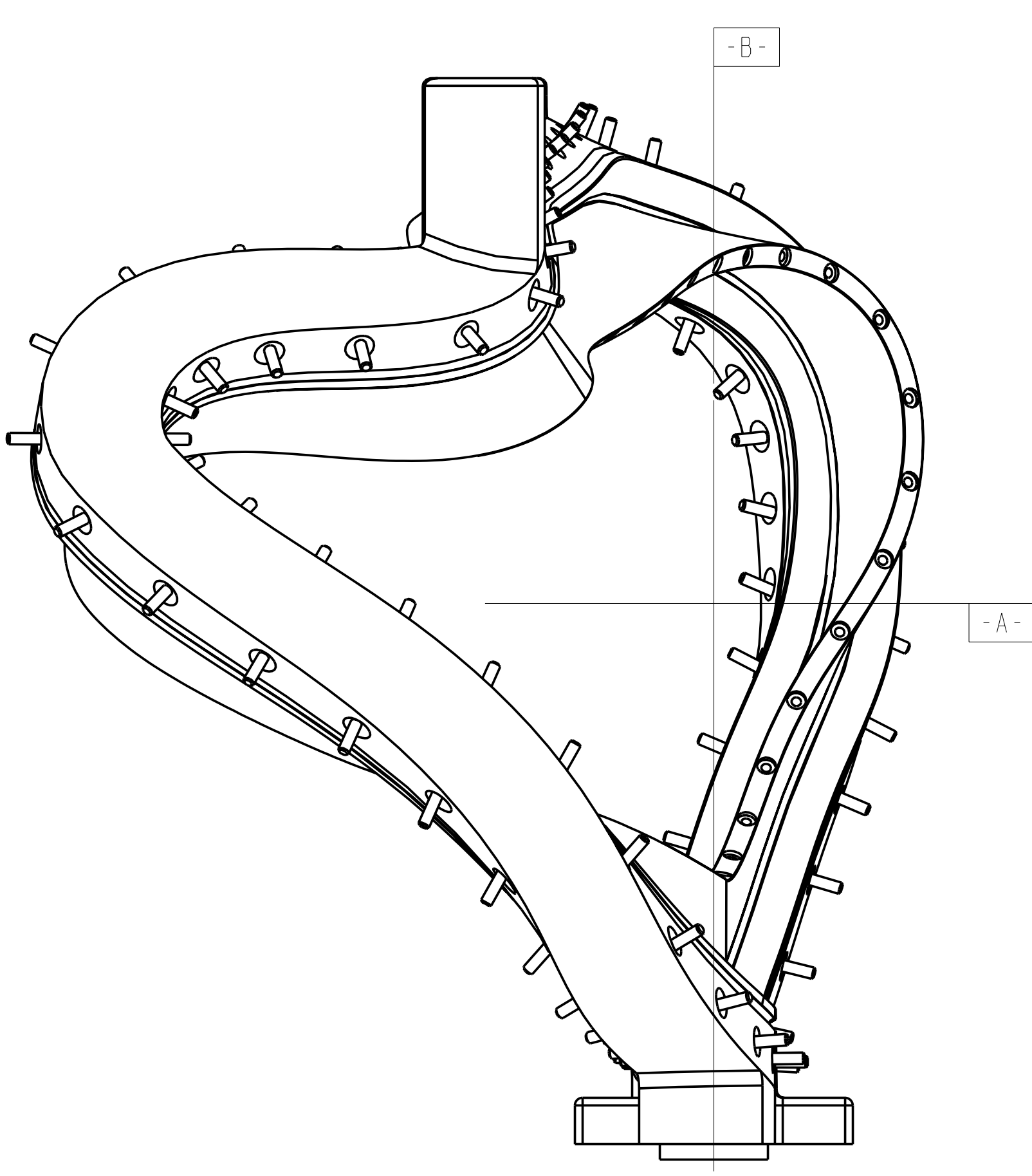
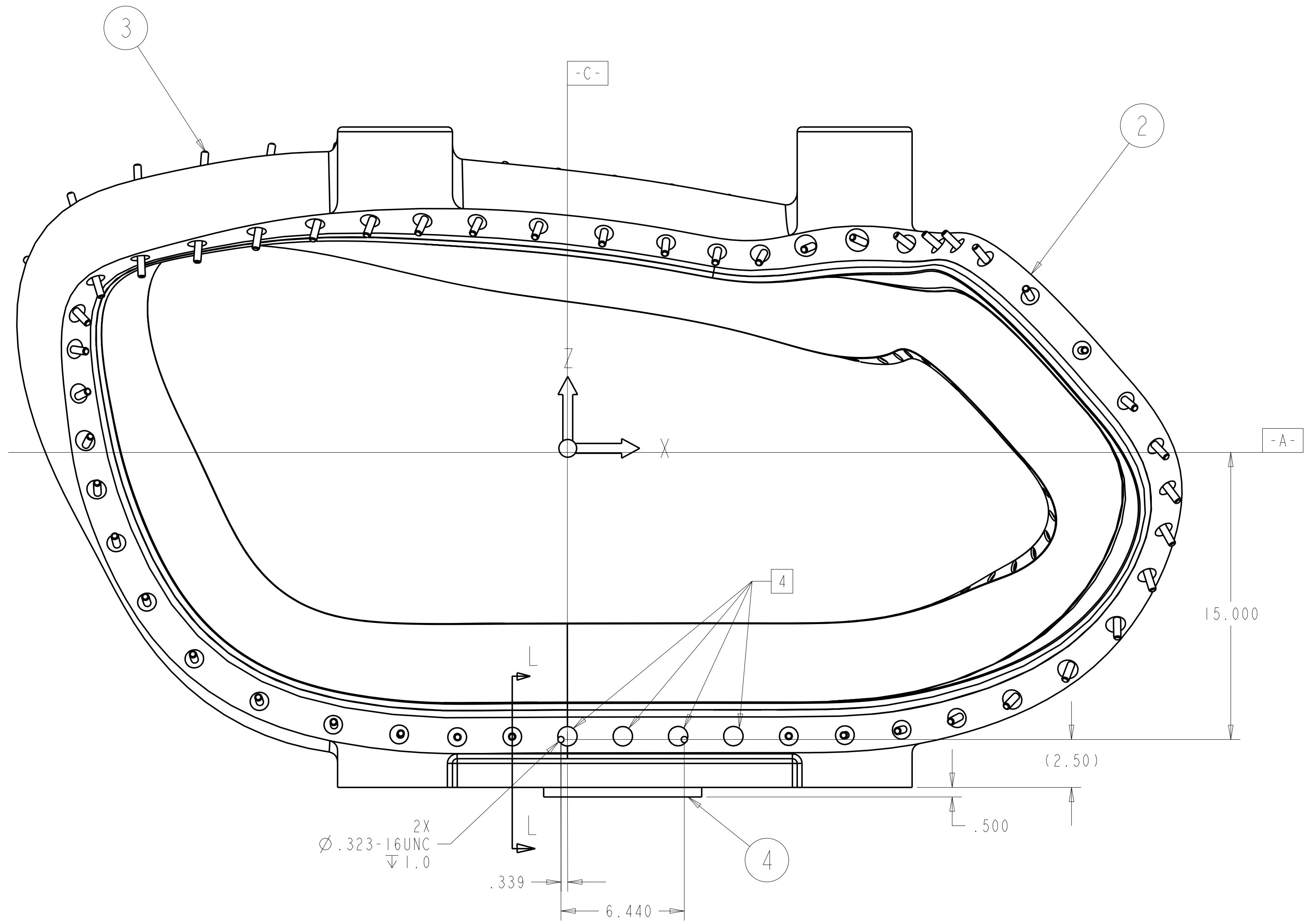

- NOTES:
1. INTERPRET DIMENSIONS AND TOLERANCES PER ANSI Y14.5M-1994.
  2. DIMENSIONS IN INCHES.
  3. APPROXIMATE WEIGHT = 727 LBS.
  4. NO STUDS (ITEM -3) IN THIS AREA.

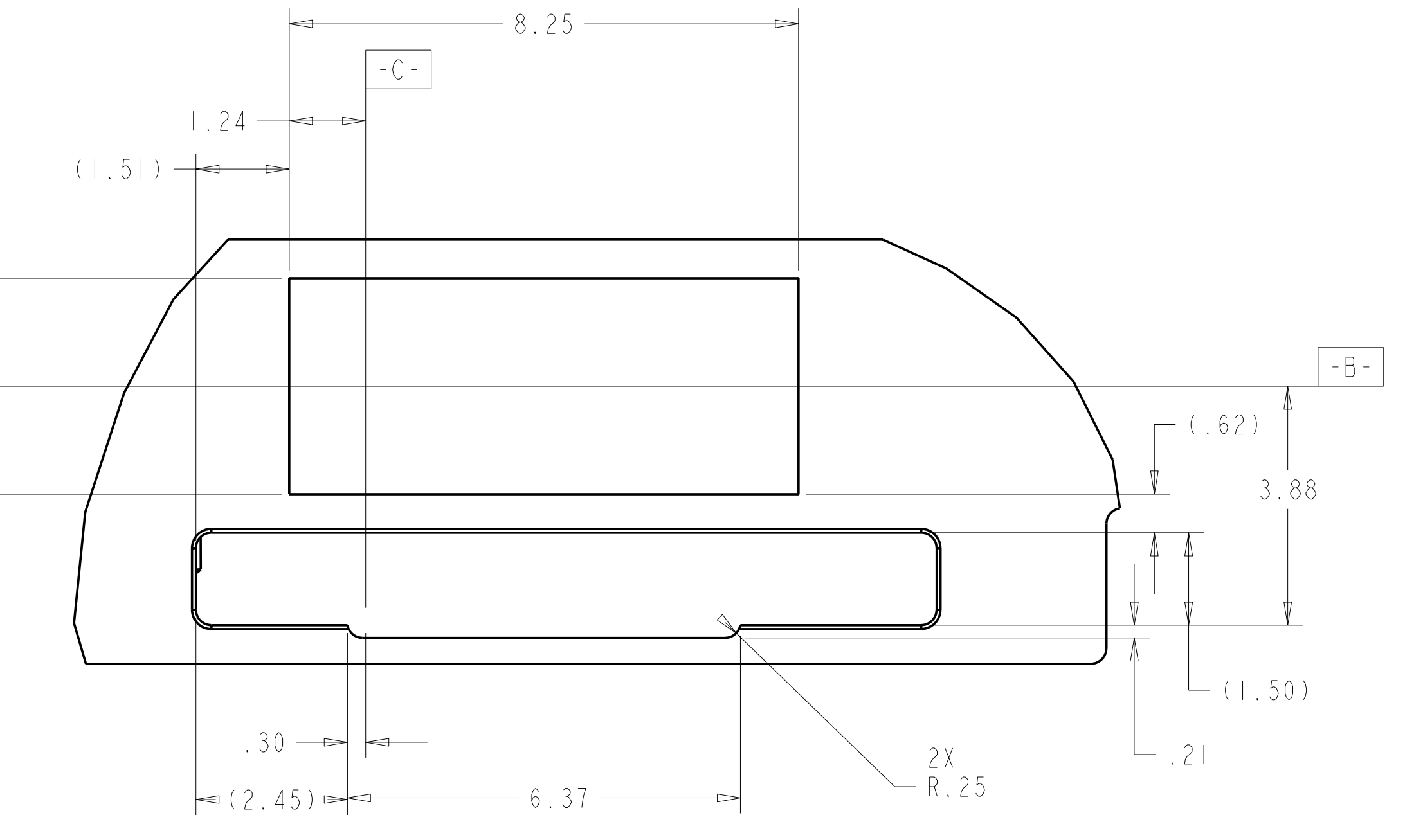

DETAIL X  
 SCALE 0.50  
 TYPICAL BOTH SIDES

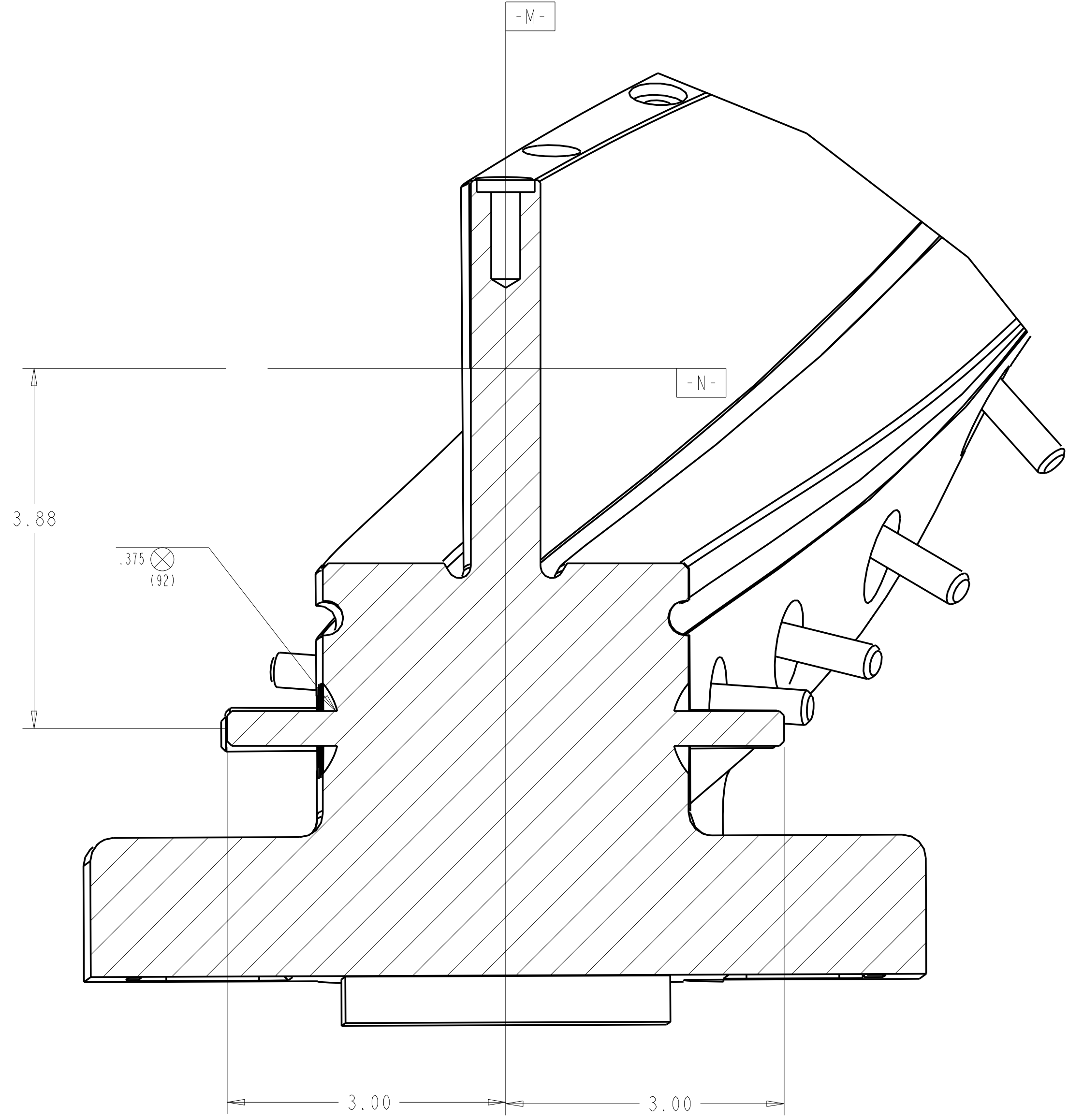
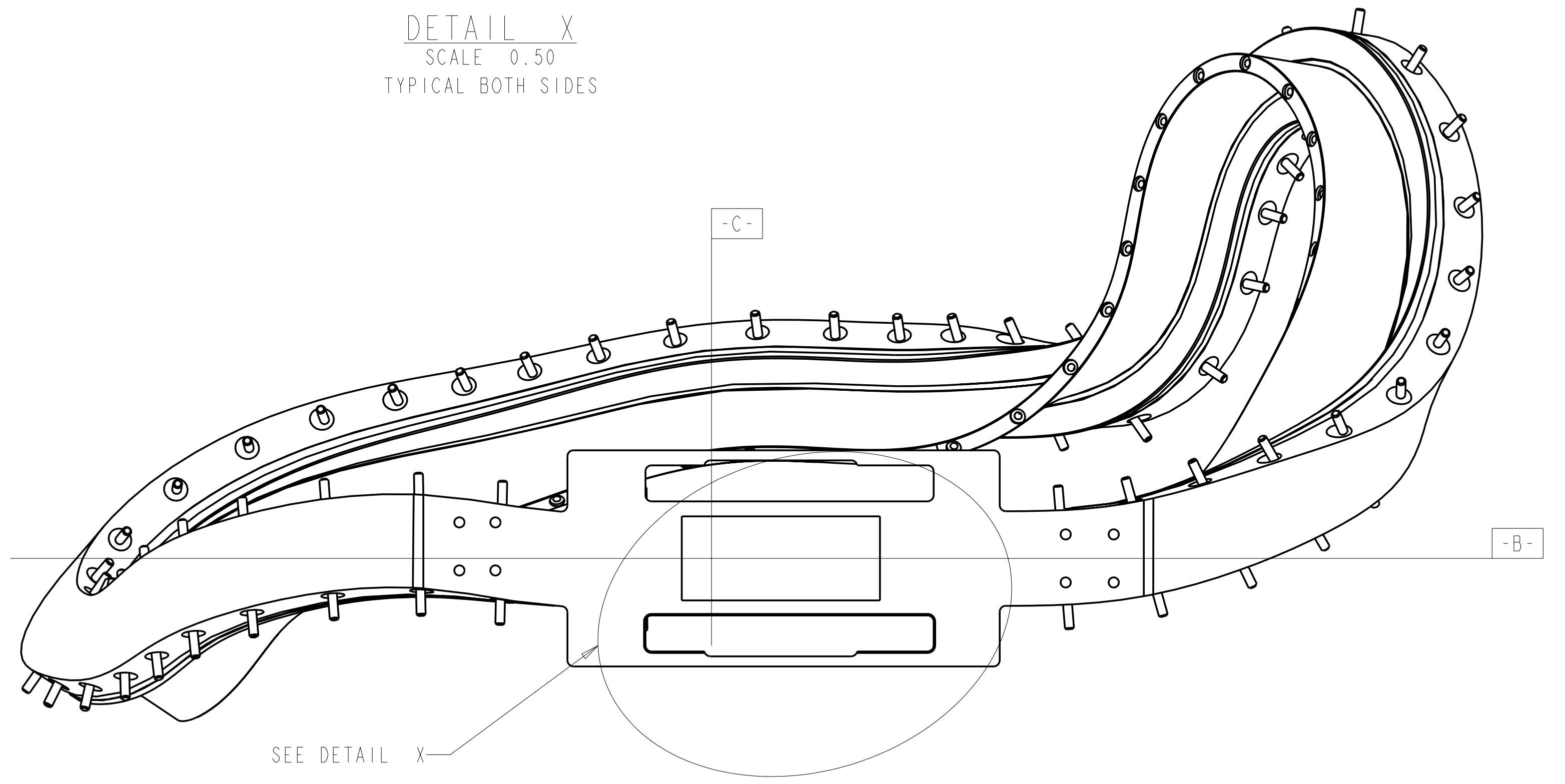

SECTION L-L  
 SCALE 1.00

TYPICAL SECTION NORMAL TO WINDING CENTER SPLINE AT STUD LOCATION

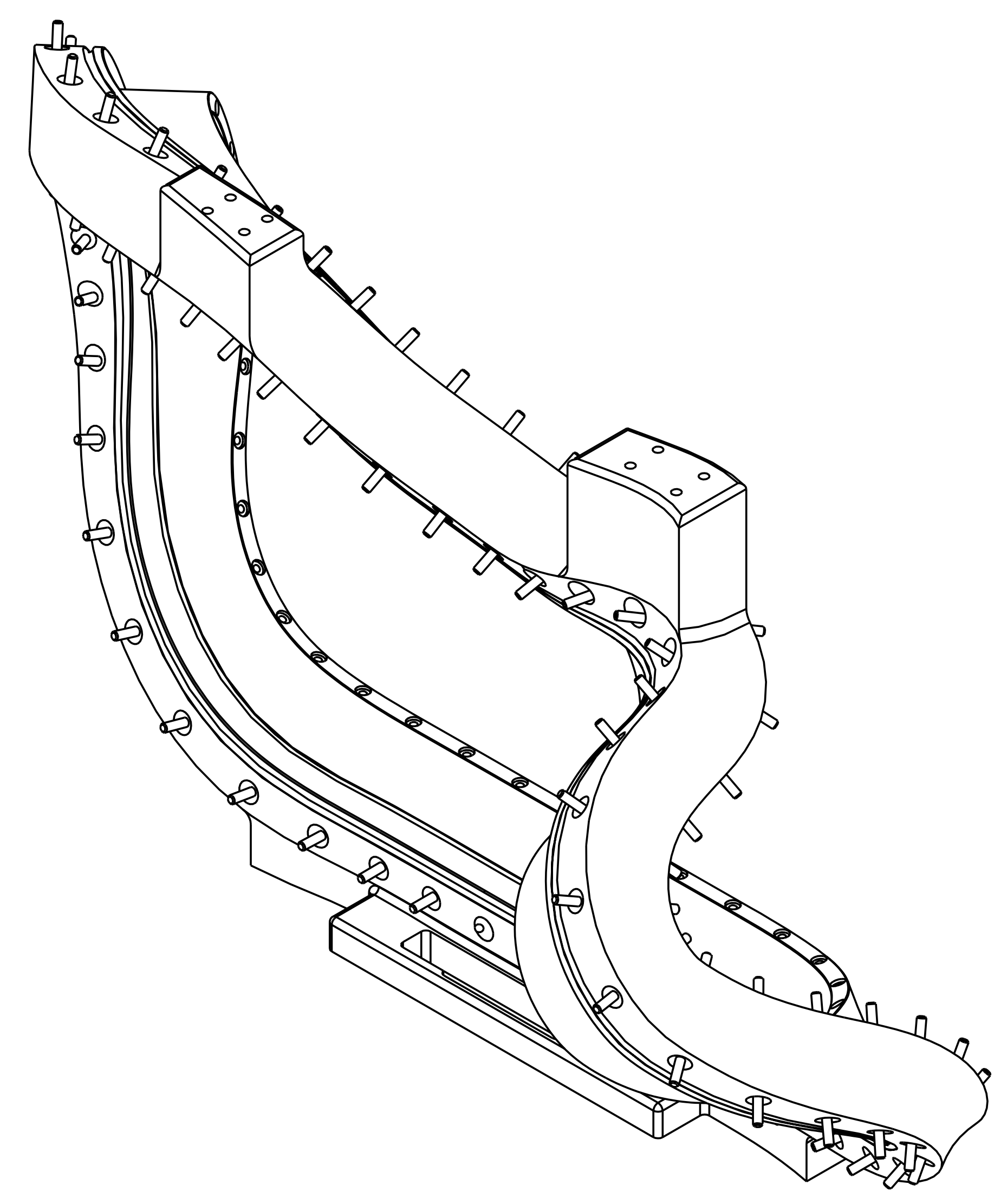

ISOMETRIC VIEW

REV	DESCRIPTION	DATE	BY	CHK	DEPT	DATE	PE	REG	DATE	DRNL	DOE	DATE
1												
2												
3												
4												
AR	X											

CAGE CODE	PART OR IDENTIFYING NO	NOMENCLATURE OR DESCRIPTION	MATERIAL	SPECIFICATION	FIND NO
-4		1/2" PLATE	SS		4
92		.375 -16UNC X 1.2 LNG WELD STUD	SS		3
I		SE140-084		TWISTED RACETRACK WINDING FORM	2
AR	X	-1		WINDING FORM WELDMENT	1

← NEXT ASSEMBLY

PARTS LIST

SCALE .25

WELDING ENGINEER  
 APPROVED R. PARSELLS DATE: 8/04

REV	DESCRIPTION	BY	DATE	CHK	DEPT	DATE	PE	REG	DATE	DRNL	DOE	DATE

SCALE NOTED

TOLERANCES UNLESS OTHERWISE SPECIFIED

FRACTIONS ±.01  
 XX DECIMALS ±.005  
 XXX DECIMALS ±.0015  
 ANGLES ±0°15'  
 BREAK SHARP EDGES .06 MAX  
 FINISH .125 UNLESS OTHERWISE SPECIFIED

DES: P FOGARTY 8-17-04  
 DRW: G LOVETT 8-17-04  
 CHK: D WILLIAMSON 8-17-04  
 SECT: :  
 DEPT: :  
 PE: D WILLIAMSON 8-17-04  
 CR: :  
 PJ: :  
 REO: :  
 PPPL DRFT: J. STEGEL 8-17-04

UT-BATTELLE  
 NATIONAL COMPACT STELLARATOR EXPERIMENT

TWISTED RACETRACK COIL WELDMENT

VERSION NO.	PLANT	BLDG	FL	SHT OF	TYPE	CLASS
12	X-10	5700	3	1	A	U

RELEASE LEVEL: Fabrication  
 SE1406-011

NO REPRESENTATION OR WARRANTY, EXPRESSED OR IMPLIED, IS MADE AS TO THE ACCURACY, COMPLETENESS OR USEFULNESS OF THE INFORMATION OR STATEMENTS CONTAINED IN THESE DRAWINGS, OR THAT THE USE OR DISCLOSURE OF ANY INFORMATION, APPARATUS, METHOD OR PROCESS DISCLOSED IN THESE DRAWINGS MAY NOT INFRINGE PRIVATE RIGHTS OF OTHERS. NO LIABILITY IS ASSUMED WITH RESPECT TO THE USE OF, OR FOR DAMAGES RESULTING FROM THE USE OF, ANY INFORMATION, APPARATUS, METHOD OR PROCESS DISCLOSED IN THESE DRAWINGS. DRAWINGS MADE AVAILABLE FOR INFORMATION TO BIDDER ARE NOT TO BE USED FOR OTHER PURPOSES, AND ARE TO BE RETURNED UPON REQUEST OF THE FORWARDING CONTRACTOR.

**P** THIS DRAWING PRODUCED ON PRO-ENGINEER

H  
G  
F  
E  
D  
C  
B  
A

- NOTES:
1. INTERPRET DIMENSIONS AND TOLERANCES PER ANSI Y14.5M
  2. DIMENSIONS ARE IN INCHES
  3. DIMENSIONS APPLY AT ROOM TEMPERATURE. OPERATING TEMP 80 K.
  4. GEOMETRY IS DEFINED IN PRO ENGINEER CAD MODELS/FILES SE1406-022.PRT
  5. DRAWING AND MODELS COMBINED DEFINE FINISHED MACHINED PART.
  6. SEE SPECIFICATION, NCSX-CSPEC 141-02-00 FOR ADDITIONAL REQUIREMENTS.
  7. SEE SPECIFICATION NCSX-CSPEC 141-02-00 SECTION 3.2.1.1 FOR MATERIAL REQUIREMENTS.1

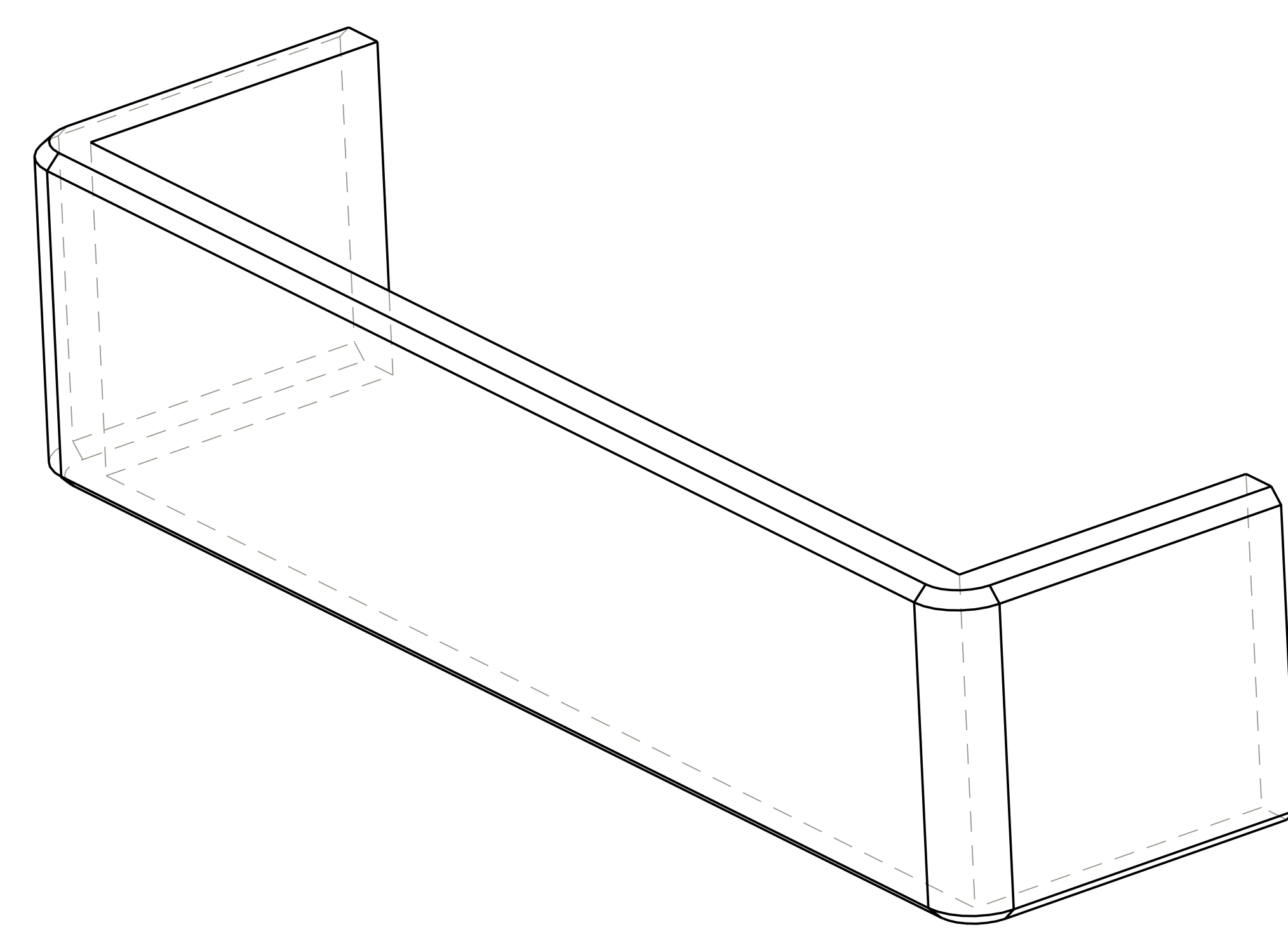
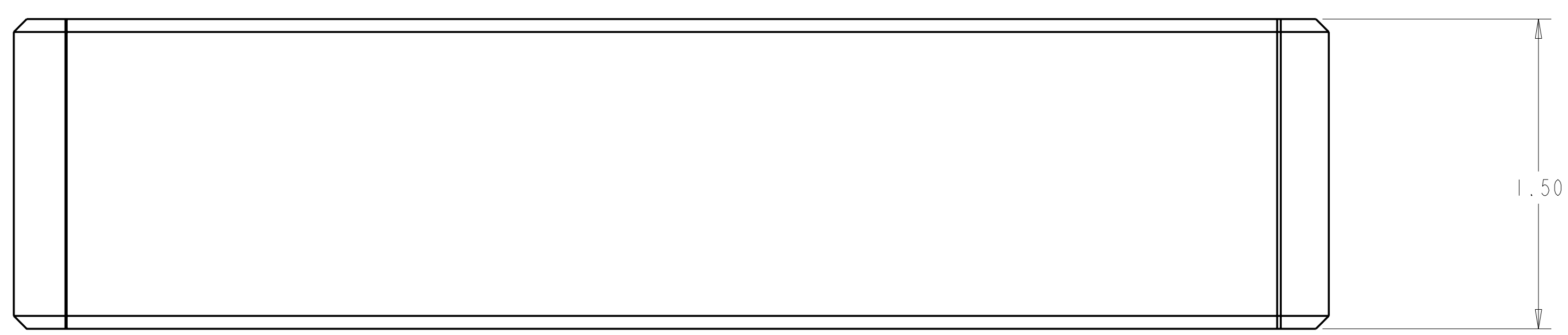

ISOMETRIC VIEW

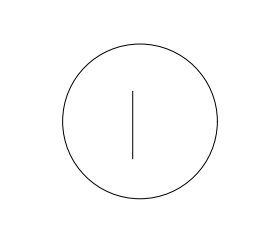
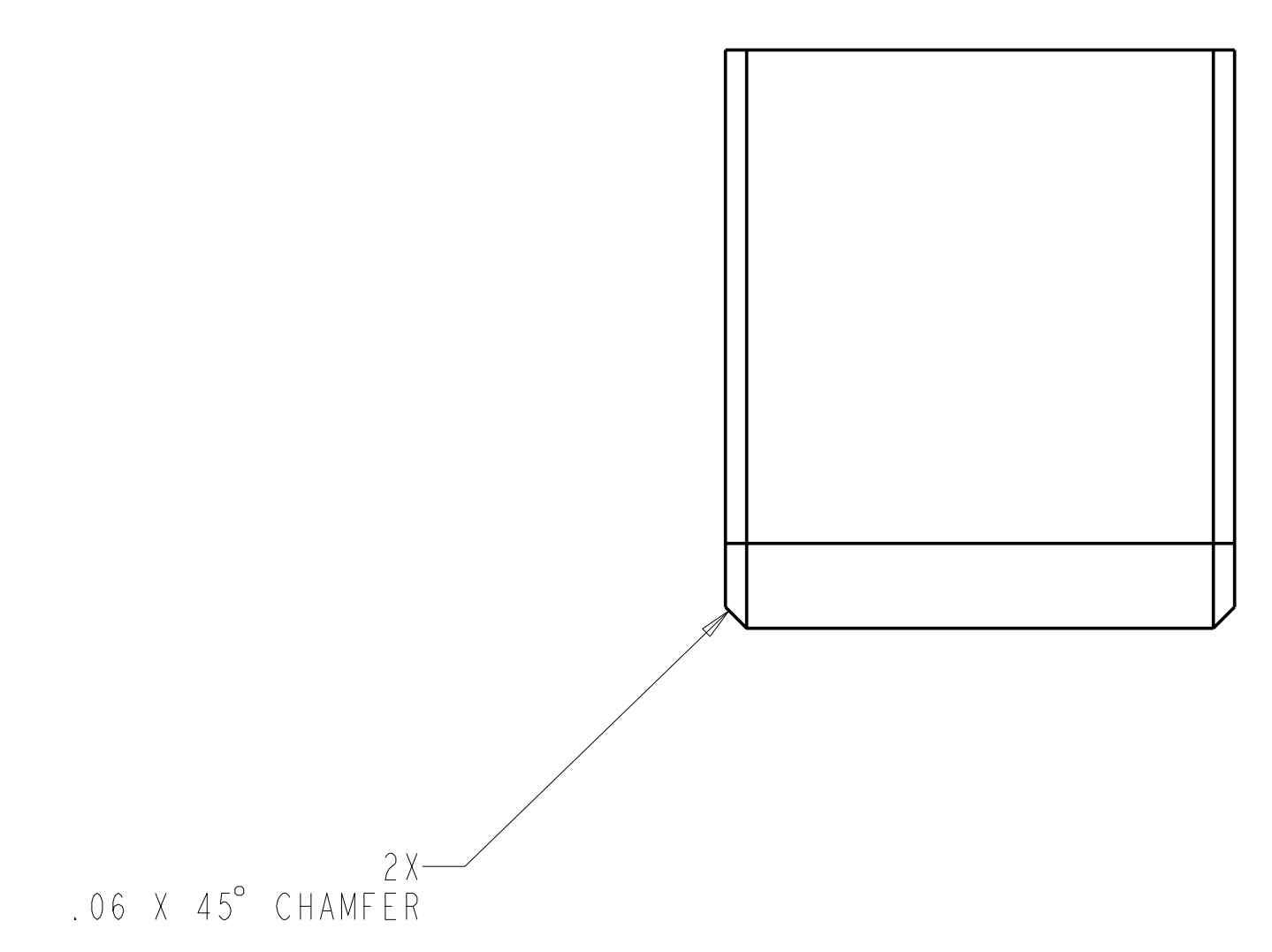
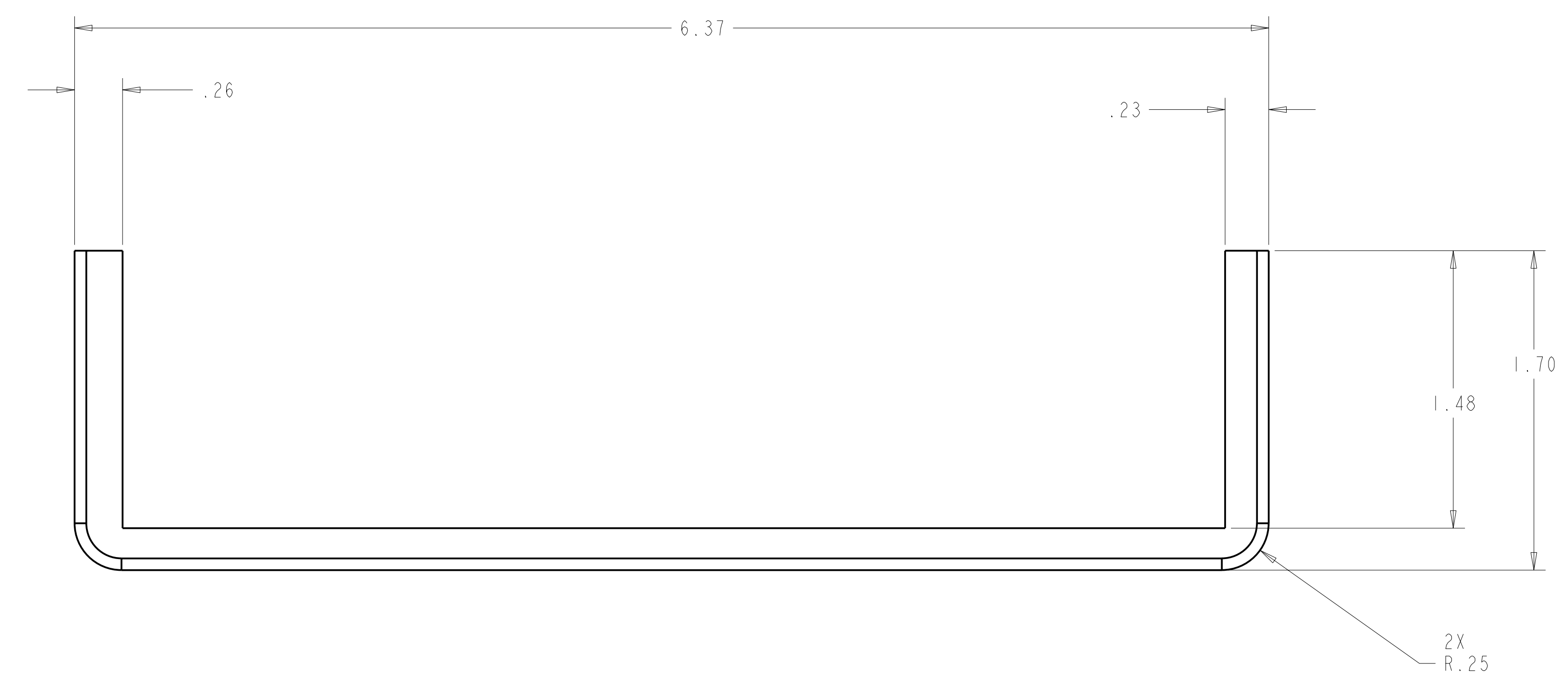

next assy	AR	-1	FILL BLOCK 2	SS316	7	SEE NOTE	6	1
SE1406-110	CAGE CODE	PART OR IDENTIFYING NO	NOMENCLATURE OR DESCRIPTION	MATERIAL	SPECIFICATION	FIND NO	PARTS LIST	
		NEXT ASSEMBLY						

NO REPRESENTATION OR WARRANTY, EXPRESSED OR IMPLIED, IS MADE AS TO THE ACCURACY, COMPLETENESS OR USEFULNESS OF THE INFORMATION OR STATEMENTS CONTAINED IN THESE DRAWINGS, OR THAT THE USE OR DISCLOSURE OF ANY INFORMATION, APPARATUS, METHOD OR PROCESS DISCLOSED IN THESE DRAWINGS MAY NOT INFRINGE PRIVATE RIGHTS OF OTHERS. NO LIABILITY IS ASSUMED WITH RESPECT TO THE USE OF, OR FOR DAMAGES RESULTING FROM THE USE OF, ANY INFORMATION, APPARATUS, METHOD OR PROCESS DISCLOSED IN THESE DRAWINGS. DRAWINGS MADE AVAILABLE FOR INFORMATION TO BIDDER ARE NOT TO BE USED FOR OTHER PURPOSES, AND ARE TO BE RETURNED UPON REQUEST OF THE FORWARDING CONTRACTOR.

**P** THIS DRAWING PRODUCED ON PRO-ENGINEER

REV	DESCRIPTION	BY	DATE	CHK	DEPT	DATE	PE	REQ	DATE	DRNL	DOE	DATE

SCALE 2:1	DES PJ FOGARTY 8-10-04	<b>UT-BATTELLE</b> Oak Ridge National Laboratory managed for the DEPARTMENT OF ENERGY under U.S. GOVERNMENT contract DE-AC05-00OR22725 UT-BATTELLE, LLC. Oak Ridge, Tennessee PROJECT NAME <b>NATIONAL COMPACT STELLARATOR EXPERIMENT</b> TRC FILL BLOCK 2
TOLERANCES UNLESS OTHERWISE SPECIFIED	DRW G LOVETT 8-10-04	
FRACTIONS	CHK G JONES 8-11-04	
XX DECIMALS ±.01	DEPT :	
XXX DECIMALS ±.005	PE D WILLIAMSON 8-11-04	VERSION NO. :
ANGLES ±0°15'	CR :	PLANT :
BREAK SHARP EDGES 06 MAX	PJ :	BLDG 5700
FINISH .125 UNLESS OTHERWISE SPECIFIED	REQ :	FL 3
	REP :	SHT OF 1
	PPPL DRFT :	TYPE I
		CLASS U
		RELEASE LEVEL
		proi_release:d
		SE1406-022
		REV 0



NOTES:

- 1. INTERPRET DIMENSIONS AND TOLERANCES PER ANSI Y14.5M
- 2. DIMENSIONS ARE IN INCHES
- 3. DIMENSIONS APPLY AT ROOM TEMPERATURE. OPERATING TEMP 80 K.
- 4. GEOMETRY IS DEFINED IN PRO ENGINEER CAD MODELS/FILES SE1406-023.PRT
- 5. DRAWING AND MODELS COMBINED DEFINE FINISHED MACHINED PART.
- 6. SEE SPECIFICATION, NCSX-CSPEC 141-02-00 FOR ADDITIONAL REQUIREMENTS.
- 7. SEE SPECIFICATION NCSX-CSPEC 141-02-00 SECTION 3.2.1.1 FOR MATERIAL REQUIREMENTS.

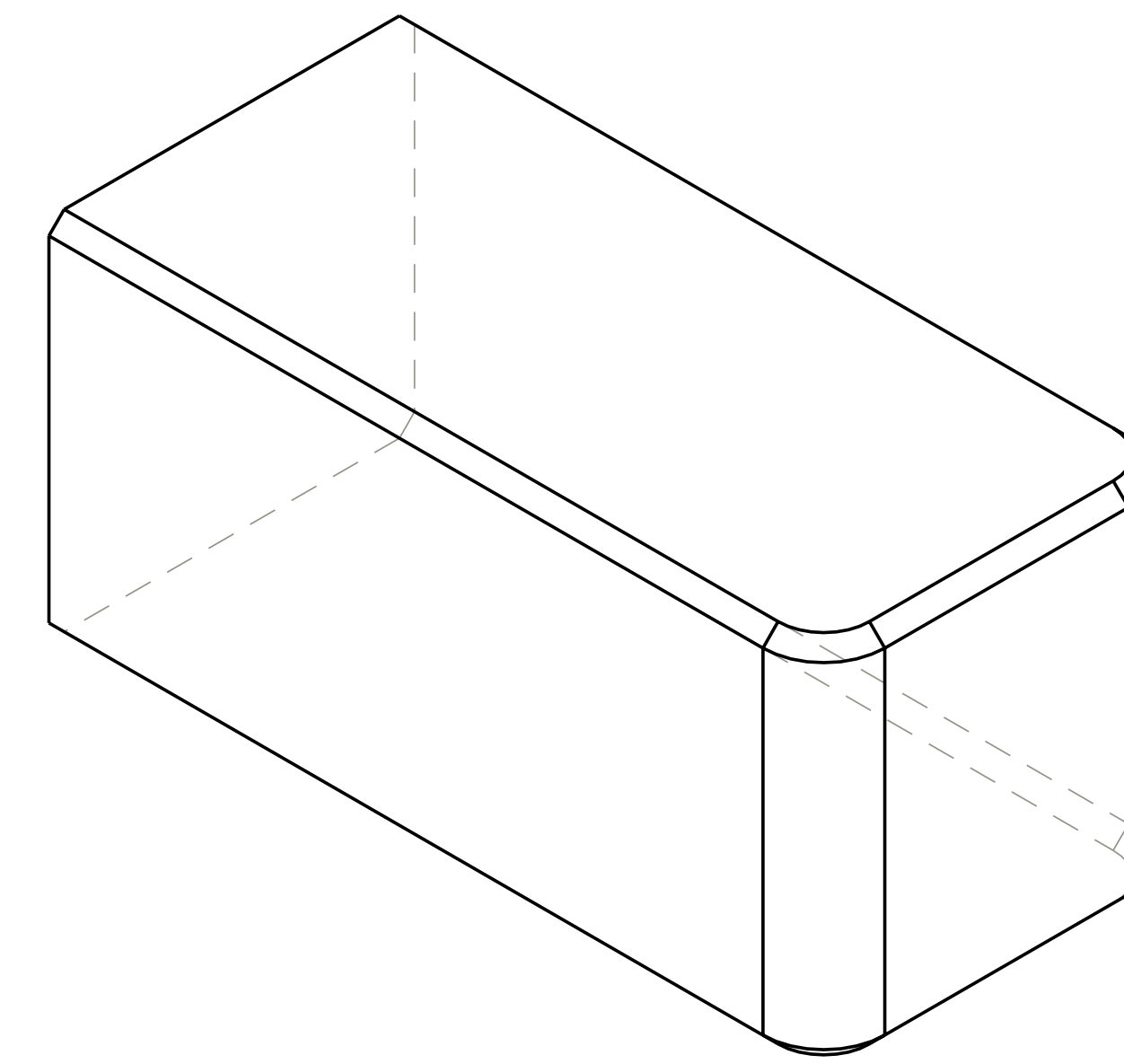
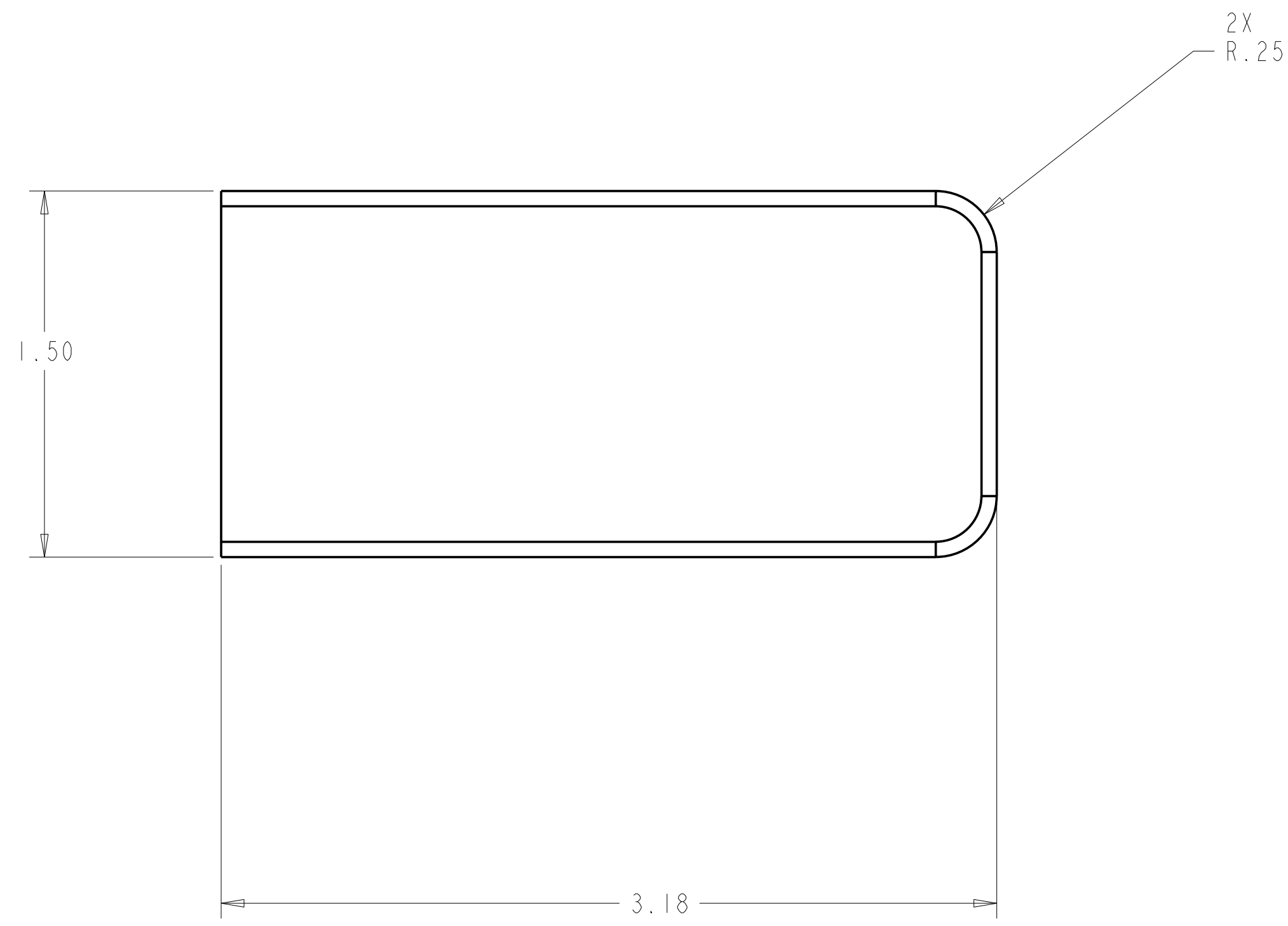

ISOMETRIC VIEW

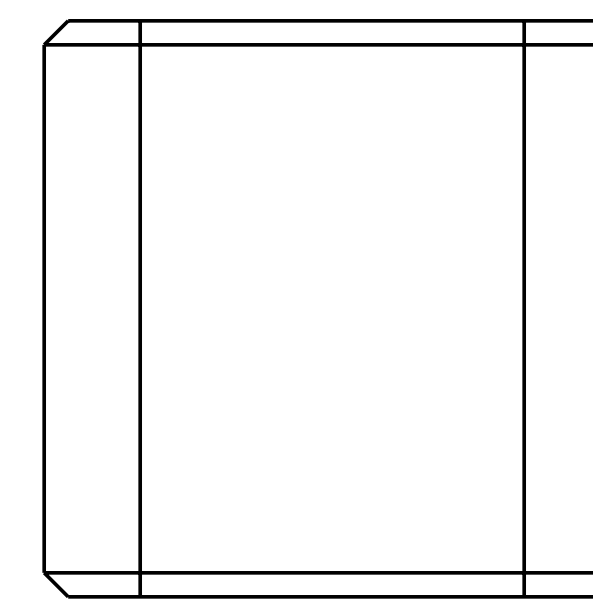
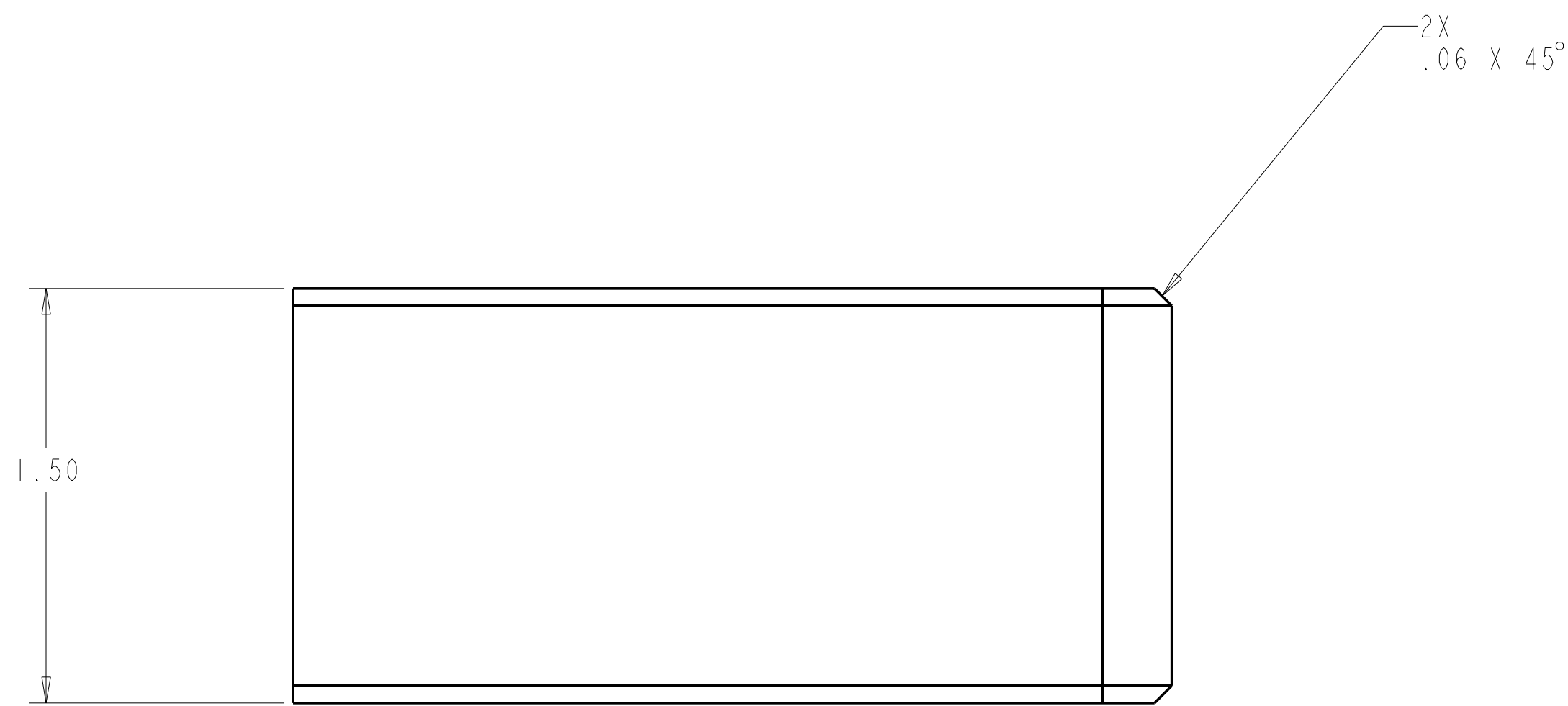

I

next assy	AR	-1	FILL BLOCK 3	316SS	7	SEE NOTE	6	I
SE1406-010	CAGE CODE	PART OR IDENTIFYING NO	NOMENCLATURE OR DESCRIPTION	MATERIAL	SPECIFICATION	FIND NO		
		NEXT ASSEMBLY	PARTS LIST					

NO REPRESENTATION OR WARRANTY, EXPRESSED OR IMPLIED, IS MADE AS TO THE ACCURACY, COMPLETENESS OR USEFULNESS OF THE INFORMATION OR STATEMENTS CONTAINED IN THESE DRAWINGS, OR THAT THE USE OR DISCLOSURE OF ANY INFORMATION, APPARATUS, METHOD OR PROCESS DISCLOSED IN THESE DRAWINGS MAY NOT INFRINGE PRIVATE RIGHTS OF OTHERS. NO LIABILITY IS ASSUMED WITH RESPECT TO THE USE OF, OR FOR DAMAGES RESULTING FROM THE USE OF, ANY INFORMATION, APPARATUS, METHOD OR PROCESS DISCLOSED IN THESE DRAWINGS. DRAWINGS MADE AVAILABLE FOR INFORMATION TO BIDDER ARE NOT TO BE USED FOR OTHER PURPOSES, AND ARE TO BE RETURNED UPON REQUEST OF THE FORWARDING CONTRACTOR.

**P** THIS DRAWING PRODUCED ON PRO-ENGINEER

REV	DESCRIPTION	BY	DATE	CHK	DEPT	DATE	PE	REQ	DATE	DRNL	DOE	DATE
REVISION OR ISSUE PURPOSE												
REVISION APPROVAL												

SCALE	2:1	DES	PJ FOGARTY	8-9-04
TOLERANCES UNLESS OTHERWISE SPECIFIED		DRW	G LOVETT	8-9-04
FRACTIONS		CHK	G JONES	8-10-04
XX DECIMALS	± .01	SECT		
XXX DECIMALS	± .005	DEPT		
ANGLES	± 0'15"	PE	D WILLIAMSON	8-10-04
BREAK SHARP EDGES	06 MAX	CR		
FINISH	.125 UNLESS OTHERWISE SPECIFIED	PJ		
		REQ		
		PPPL	DRFT	

<b>UT-BATTELLE</b>		Oak Ridge National Laboratory managed for the DEPARTMENT OF ENERGY under U.S. GOVERNMENT CONTRACT DE-AC05-00OR22725 UT-BATTELLE, LLC. Oak Ridge, Tennessee			
NATIONAL COMPACT STELLARATOR EXPERIMENT					
TRC FILL BLOCK 3					
VERSION NO.	PLANT	BLDG	FL	SHT OF	TYPE CLASS
0	X-10	5700	3	1	I S U
RELEASE LEVEL	SE1406-023				REV 0
WIP					

SE1406-023

A

- NOTES:
1. INTERPRET DIMENSIONS AND TOLERANCES PER ANSI Y14.5M
  2. DIMENSIONS ARE IN INCHES
  3. DIMENSIONS APPLY AT ROOM TEMPERATURE, OPERATING TEMP 80 K.
  4. GEOMETRY IS DEFINED IN PRO ENGINEER CAD MODELS/FILES SEI406-024.PRT
  5. DRAWING AND MODELS COMBINED DEFINE FINISHED MACHINED PART.
  6. SEE SPECIFICATION, NCSX-CSPEC 141-02-00 FOR ADDITIONAL REQUIREMENTS.
  7. SEE SPECIFICATION NCSX-CSPEC 141-02-00 SECTION 3.2.1.1 FOR MATERIAL REQUIREMENTS.1

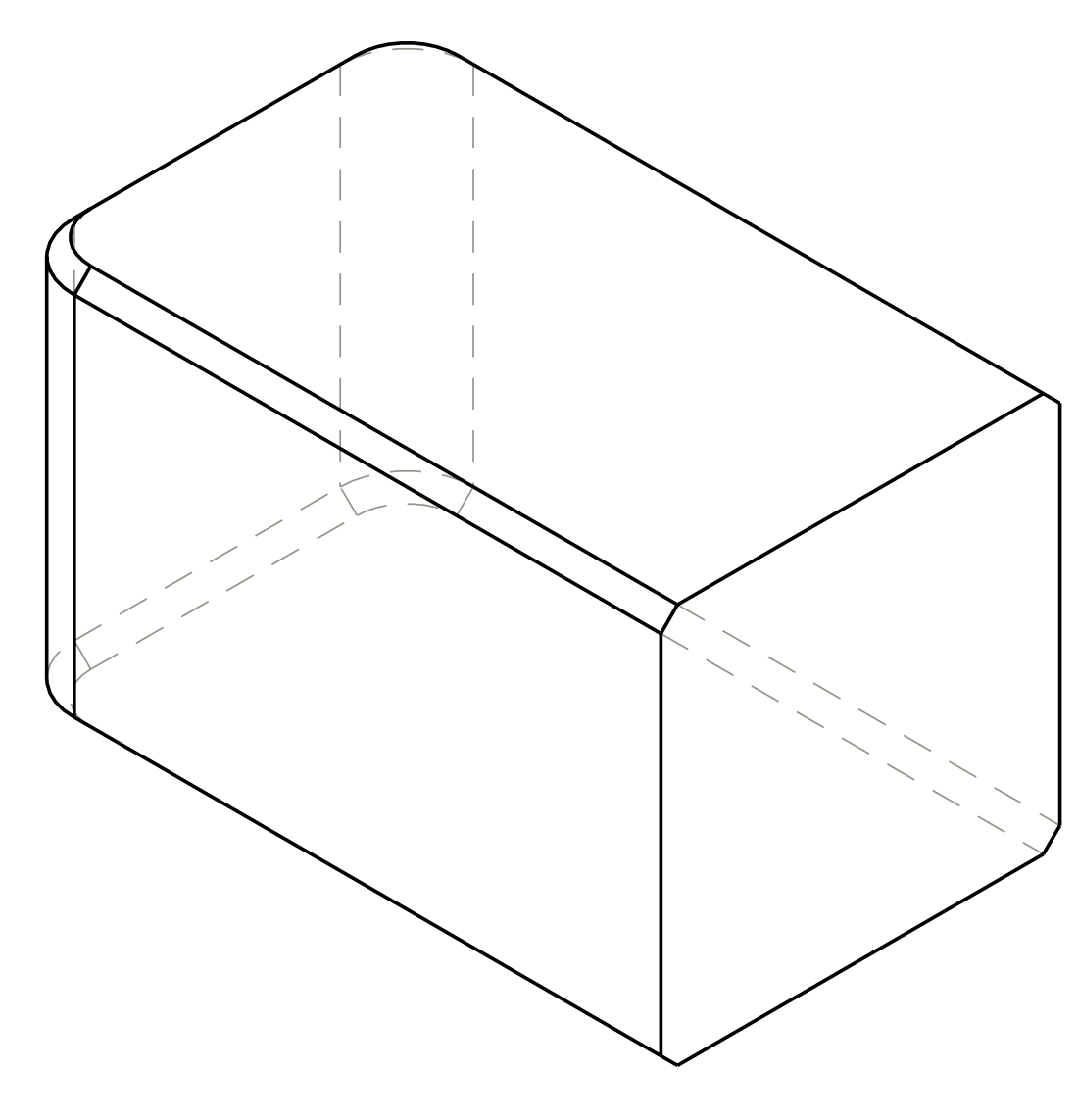
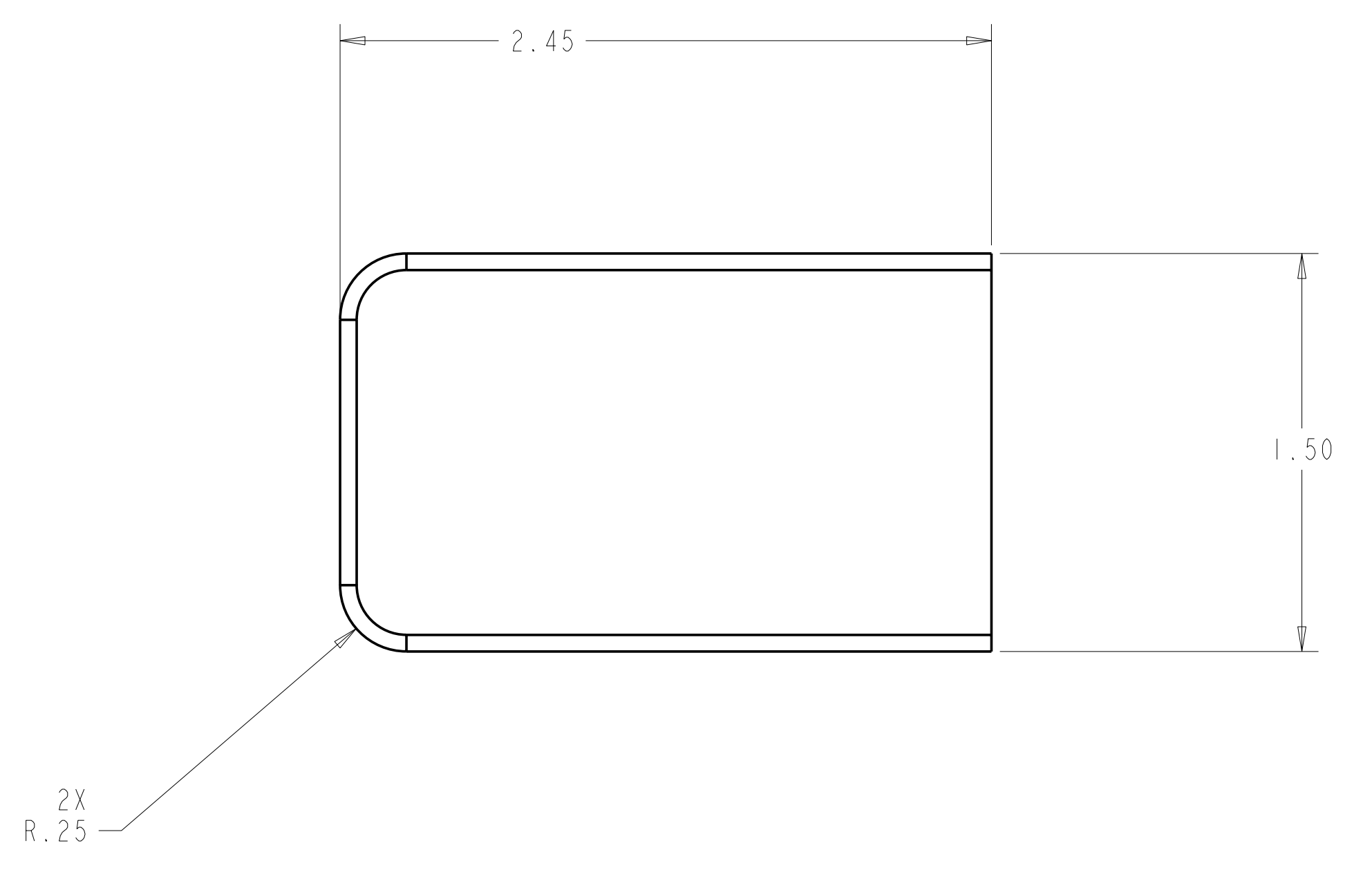

ISOMETRIC VIEW

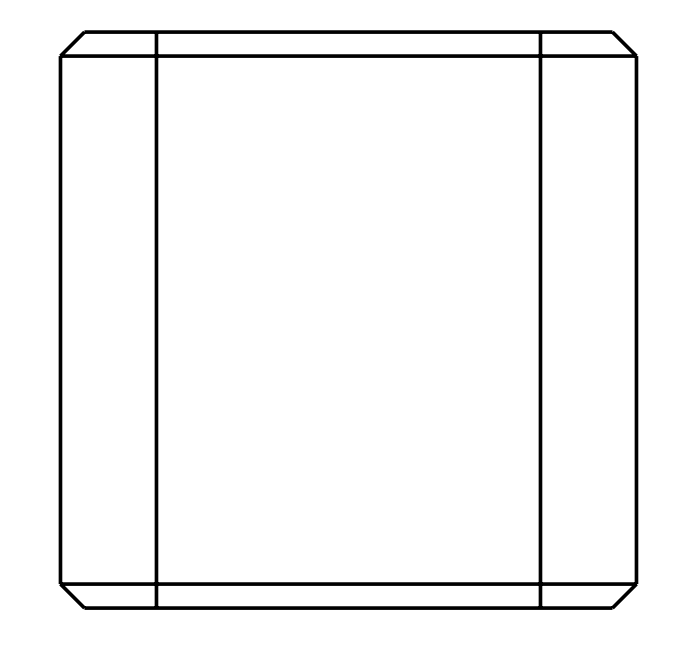
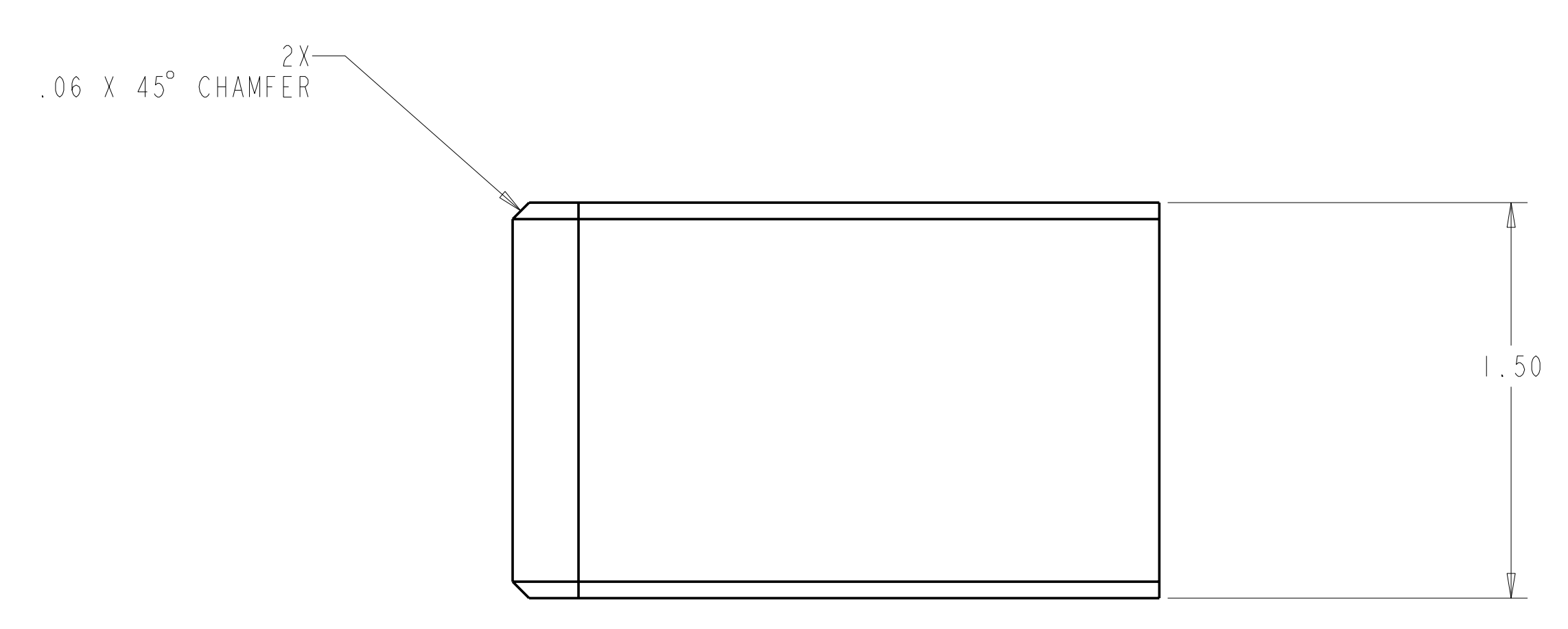

1

next assy	AR	-1	FILL BLOCK 1	SS316 7	SEE NOTE 6	1
SEI406-010 5	CAGE CODE	PART OR IDENTIFYING NO	NOMENCLATURE OR DESCRIPTION	MATERIAL	SPECIFICATION	FIND NO
			NEXT ASSEMBLY	PARTS LIST		

NO REPRESENTATION OR WARRANTY, EXPRESSED OR IMPLIED, IS MADE AS TO THE ACCURACY, COMPLETENESS OR USEFULNESS OF THE INFORMATION OR STATEMENTS CONTAINED IN THESE DRAWINGS, OR THAT THE USE OR DISCLOSURE OF ANY INFORMATION, APPARATUS, METHOD OR PROCESS DISCLOSED IN THESE DRAWINGS MAY NOT INFRINGE PRIVATE RIGHTS OF OTHERS. NO LIABILITY IS ASSUMED WITH RESPECT TO THE USE OF, OR FOR DAMAGES RESULTING FROM THE USE OF, ANY INFORMATION, APPARATUS, METHOD OR PROCESS DISCLOSED IN THESE DRAWINGS. DRAWINGS MADE AVAILABLE FOR INFORMATION TO BIDDER ARE NOT TO BE USED FOR OTHER PURPOSES, AND ARE TO BE RETURNED UPON REQUEST OF THE FORWARDING CONTRACTOR.

**P** THIS DRAWING PRODUCED ON PRO-ENGINEER

REV	DESCRIPTION	BY	DATE	CHK	DEPT	DATE	PE	REQ	DATE	ORNL	DOE	DATE
REVISION OR ISSUE PURPOSE		REVISION APPROVAL										

SCALE 2 : 1			
TOLERANCES UNLESS OTHERWISE SPECIFIED	DES: PJ FOGARTY 8-11-04	DRW: G LOVETT 8-11-04	CHK: G JONES 8-11-04
FRACTIONS ± .01	PE: D WILLIAMSON 8-11-04	CR: ± .005	PJ: ± .015
XXX DECIMALS ± .005	REO: ± .015	ANGLS ± 0°15'	MAX: ± .015
FINISH .125 UNLESS OTHERWISE SPECIFIED	PPPL DRFT	PPPL DRFT	PPPL DRFT

**UT-BATTELLE** Oak Ridge National Laboratory managed for the DEPARTMENT OF ENERGY under U.S. GOVERNMENT contract DE-AC05-00OR22725 UT-BATTELLE, LLC, Oak Ridge, Tennessee

**NATIONAL COMPACT STELLARATOR EXPERIMENT**

TRC FILL BLOCK 1

VERSION NO.	PLANT	BLDG	FL	SHT OF	TYPE	CLASS
0	X-10	5700	3	1	I	S U
RELEASE LEVEL	SEI406-024			REV	0	
WIP						

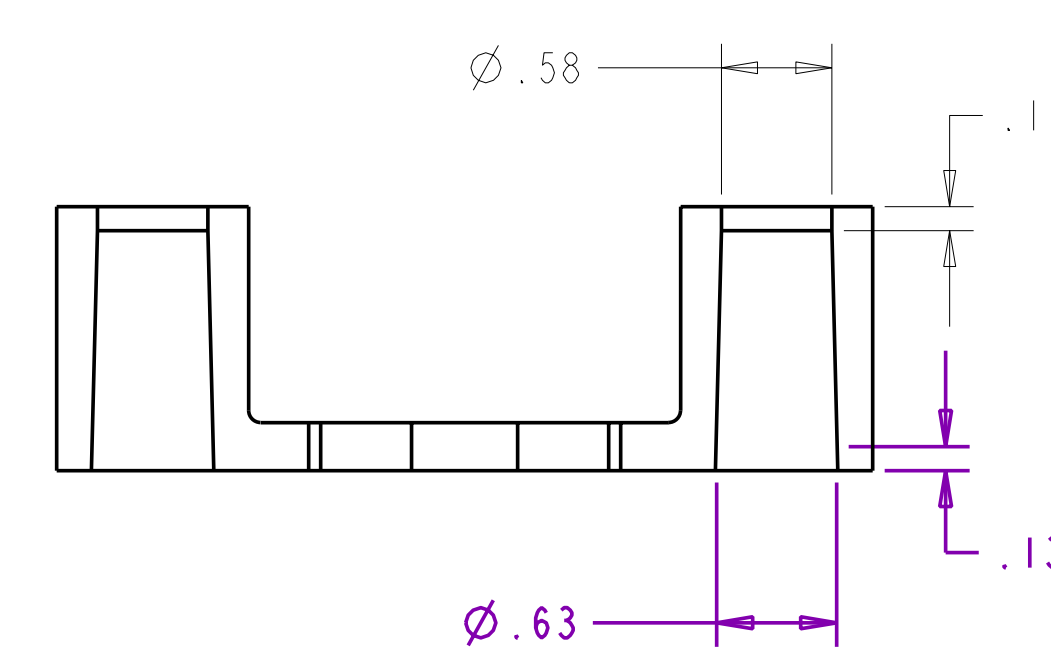
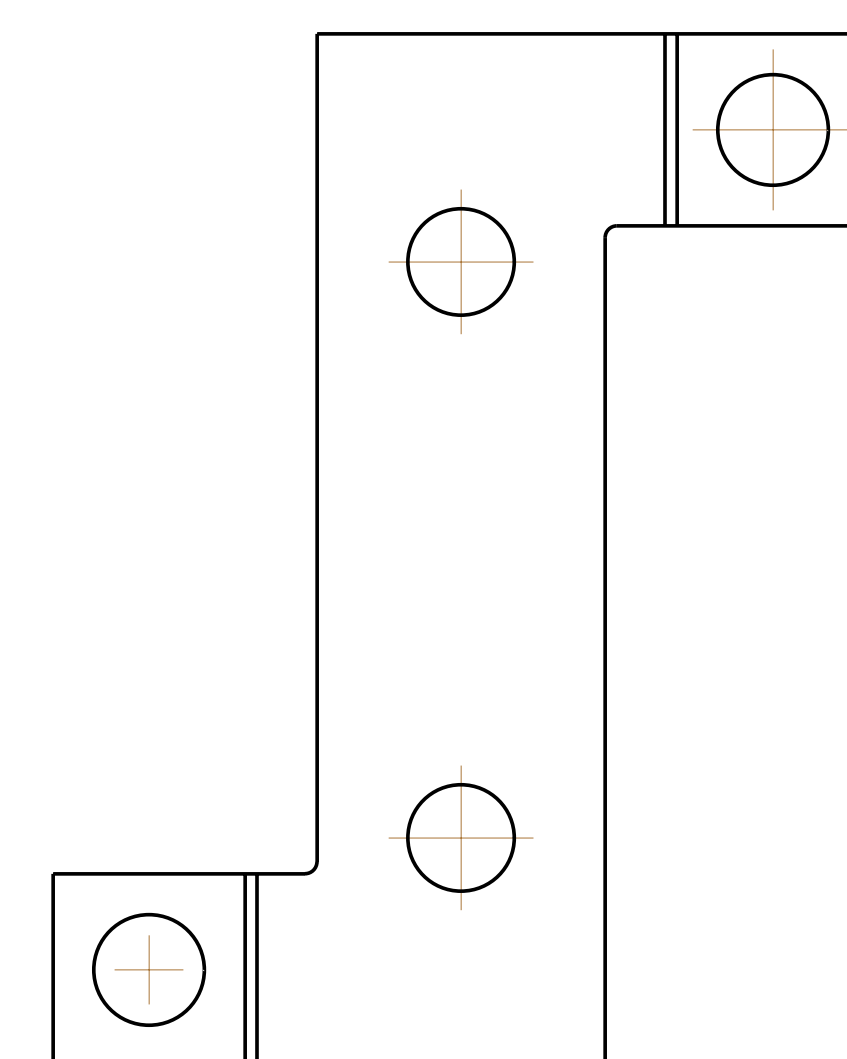
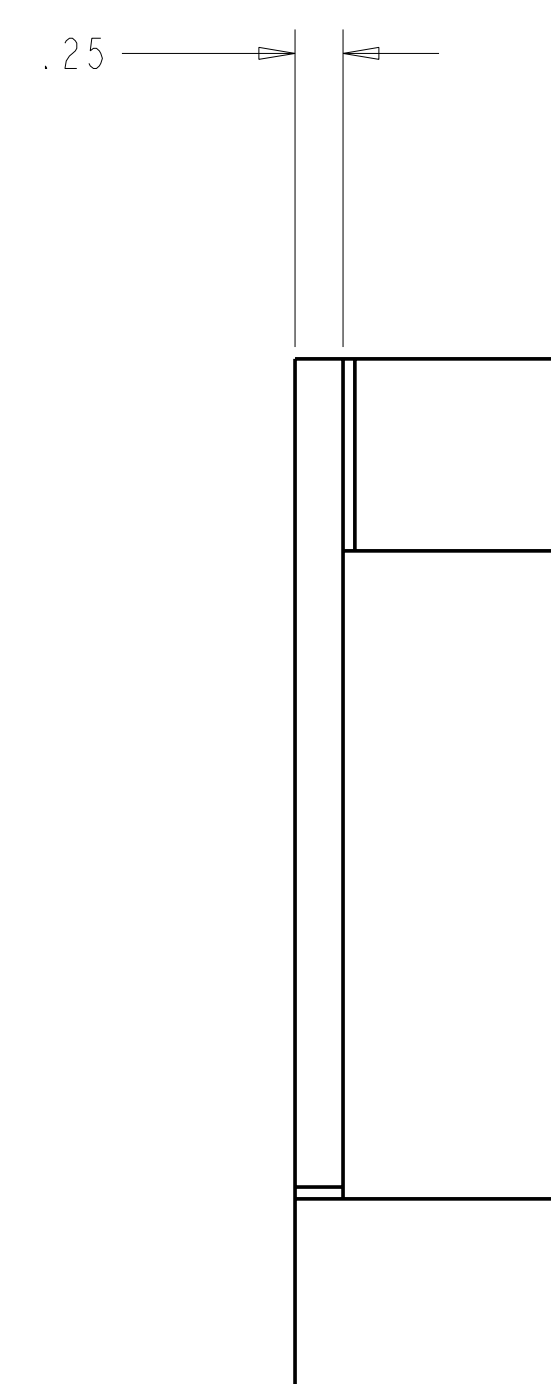
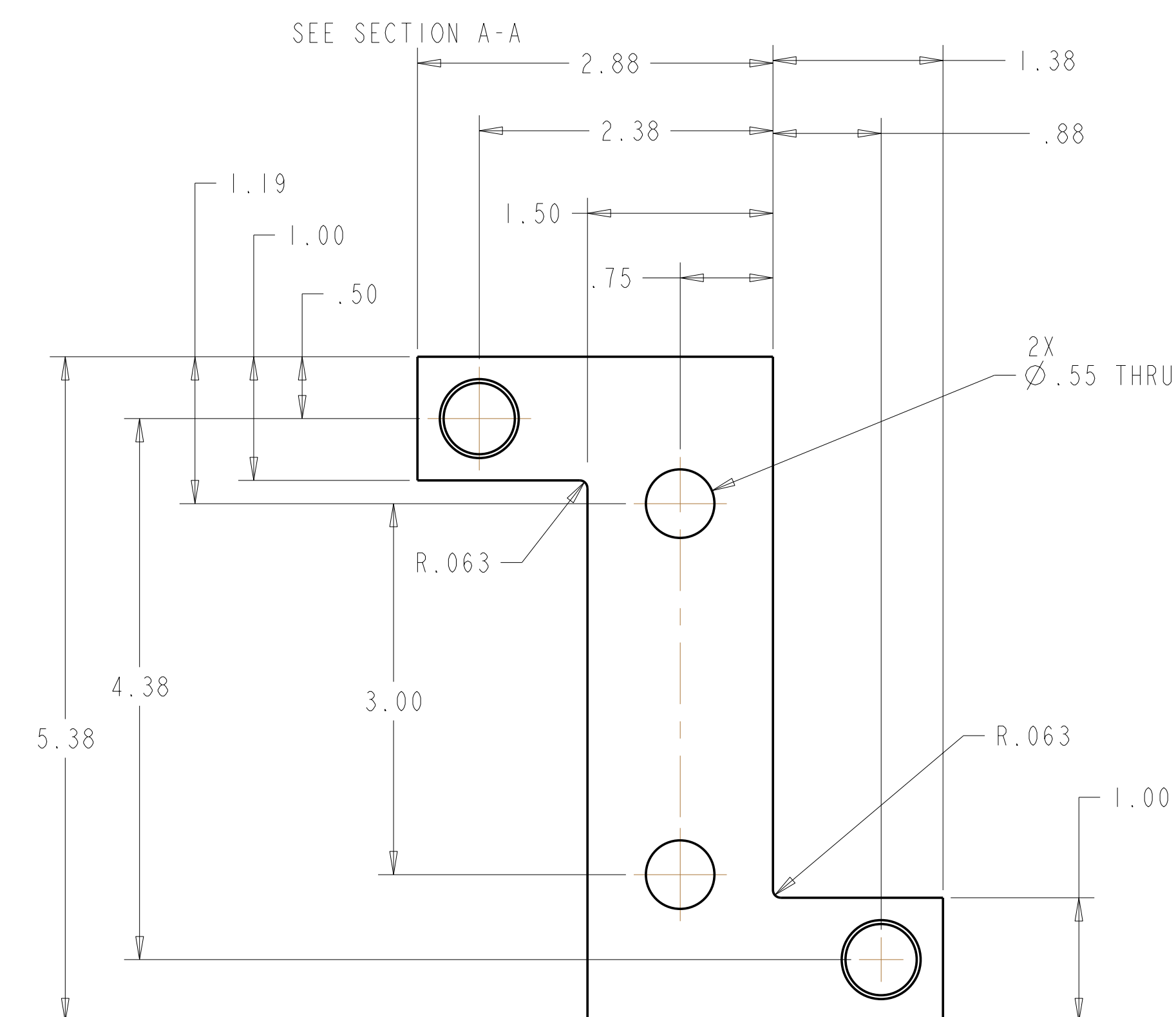
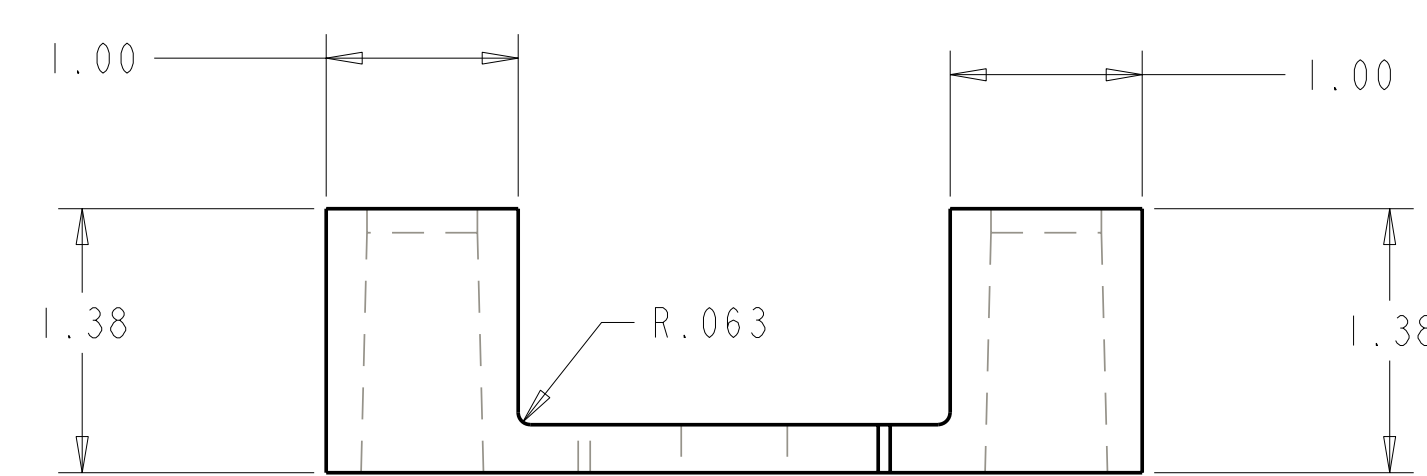

- NOTES:
1. INTERPRET DIMENSIONS AND TOLERANCES PER ANSI Y14.5M
  2. DIMENSIONS ARE IN INCHES
  3. DIMENSIONS APPLY AT ROOM TEMPERATURE. OPERATING TEMP 80 K.
  4. GEOMETRY IS DEFINED IN PRO ENGINEER CAD MODELS/FILES SEI406-051.PRT
  5. DRAWING AND MODELS COMBINED DEFINE FINISHED MACHINED PART.
  6. SEE SPECIFICATION, NCSX-CSPEC 141-02-00 FOR ADDITIONAL REQUIREMENTS.
  7. SEE SPECIFICATION NCSX-CSPEC 141-02-00 SECTION 3.2.1.1 FOR MATERIAL REQUIREMENTS.1

I

ISOMETRIC VIEW

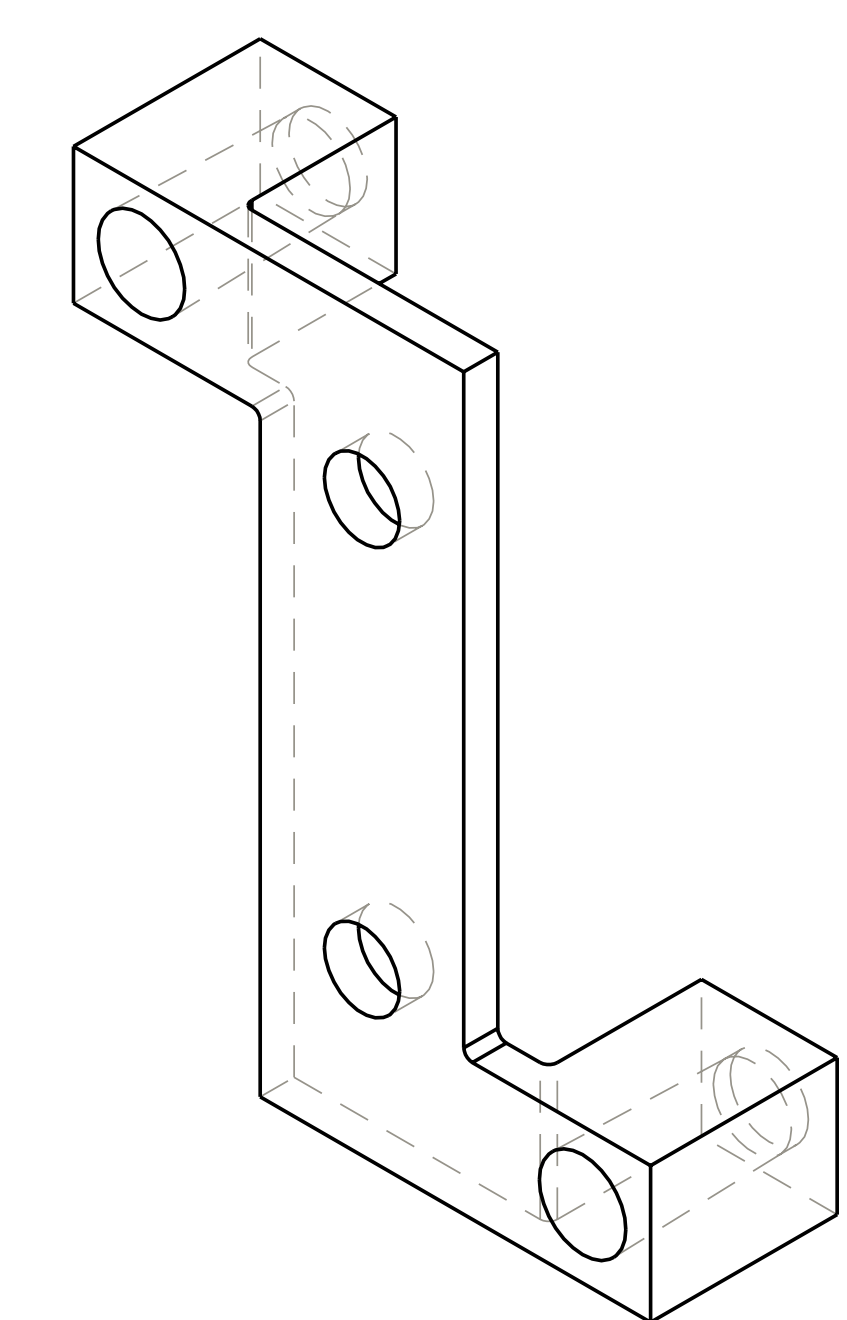

SCALE 1.000  
TYPICAL 2 PLACES

next assy	AR	-1	JUMPER 1	COPPER 7	SEE NOTE 6	I
SEI406-010	CAGE CODE	PART OR IDENTIFYING NO	NOMENCLATURE OR DESCRIPTION	MATERIAL	SPECIFICATION	FIND NO
		NEXT ASSEMBLY	PARTS LIST			

REV	DESCRIPTION	BY	DATE	CHK	DEPT	DATE	PE	REQ	DATE	DRNL	DOE	DATE	SCALE 1:1	DES PJ FOGARTY 8-12-04	DRW G LOVETT 8-12-04	CHK G JONES 8-12-04	SECT :	DEPT :	PE D WILLIAMSON 8-12-04	CR :	PJ :	REO :	PPPL DRFT :	VERSION NO. 0	PLANT X-10	BLDG 5700	FL 3	SHT OF 1	TYPE I	CLASS U	REV 0
													TOLERANCES UNLESS OTHERWISE SPECIFIED		Oak Ridge National Laboratory managed for the DEPARTMENT OF ENERGY under U.S. GOVERNMENT contract DE-AC05-00OR22725 UT-BATTELLE, LLC. Oak Ridge, Tennessee																
													FRACTIONS ±.01		NATIONAL COMPACT STELLARATOR EXPERIMENT																
													XXX DECIMALS ±.005		JUMPER 1																
													ANGLES ±0°15'																		
													FINISH .125 UNLESS OTHERWISE SPECIFIED																		
													BREAK SHARP EDGES .06 MAX																		
													REVISION APPROVAL																		

P THIS DRAWING PRODUCED ON PRO-ENGINEER

NO REPRESENTATION OR WARRANTY, EXPRESSED OR IMPLIED, IS MADE AS TO THE ACCURACY, COMPLETENESS OR USEFULNESS OF THE INFORMATION OR STATEMENTS CONTAINED IN THESE DRAWINGS, OR THAT THE USE OR DISCLOSURE OF ANY INFORMATION, APPARATUS, METHOD OR PROCESS DISCLOSED IN THESE DRAWINGS MAY NOT INFRINGE PRIVATE RIGHTS OF OTHERS. NO LIABILITY IS ASSUMED WITH RESPECT TO THE USE OF, OR FOR DAMAGES RESULTING FROM THE USE OF, ANY INFORMATION, APPARATUS, METHOD OR PROCESS DISCLOSED IN THESE DRAWINGS. DRAWINGS MADE AVAILABLE FOR INFORMATION TO BIDDER ARE NOT TO BE USED FOR OTHER PURPOSES, AND ARE TO BE RETURNED UPON REQUEST OF THE FORWARDING CONTRACTOR.

SEI406-051

A

8

7

6

5

4

3

2

1

NEXT ASS'Y: 1 FINAL ASS'Y:

- NOTES:
1. INTERPRET DIMENSIONS AND TOLERANCES PER ANSI Y14.5M
  2. DIMENSIONS ARE IN INCHES
  3. DIMENSIONS APPLY AT ROOM TEMPERATURE. OPERATING TEMP 80 K.
  4. GEOMETRY IS DEFINED IN PRO-ENGINEER CAD MODELS/FILES SE1406-052.PRT
  5. DRAWING AND MODELS COMBINED DEFINE FINISHED MACHINED PART.
  6. SEE SPECIFICATION, NCSX-CSPEC 141-02-00 FOR ADDITIONAL REQUIREMENTS.
  7. SEE SPECIFICATION NCSX-CSPEC 141-02-00 SECTION 3.2.1.1 FOR MATERIAL REQUIREMENTS.1

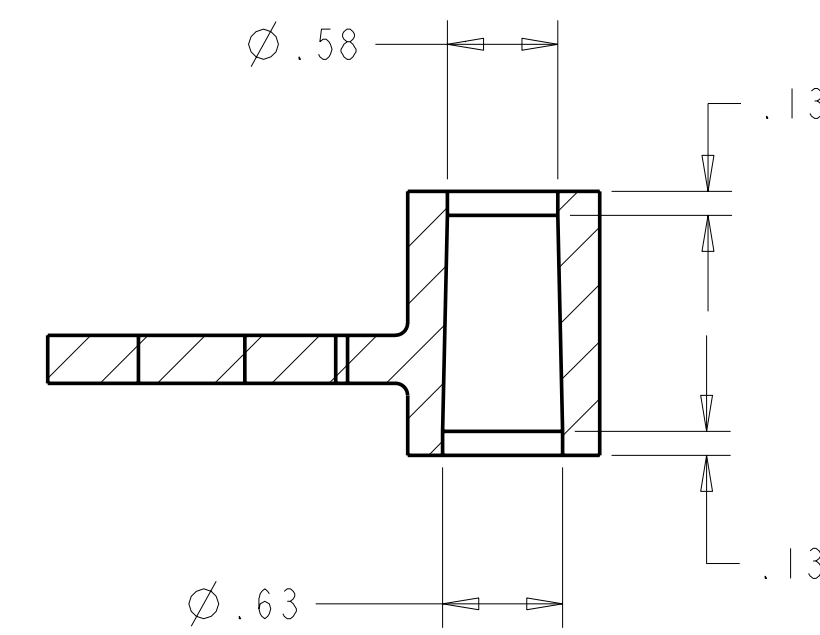
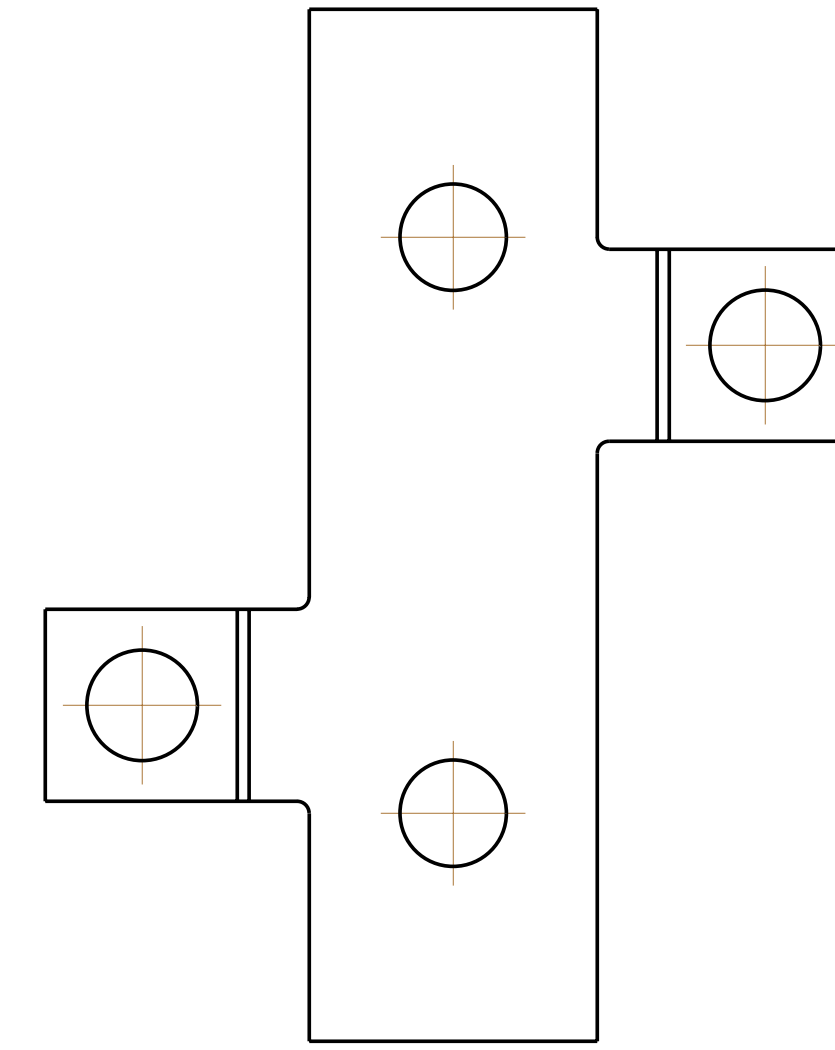
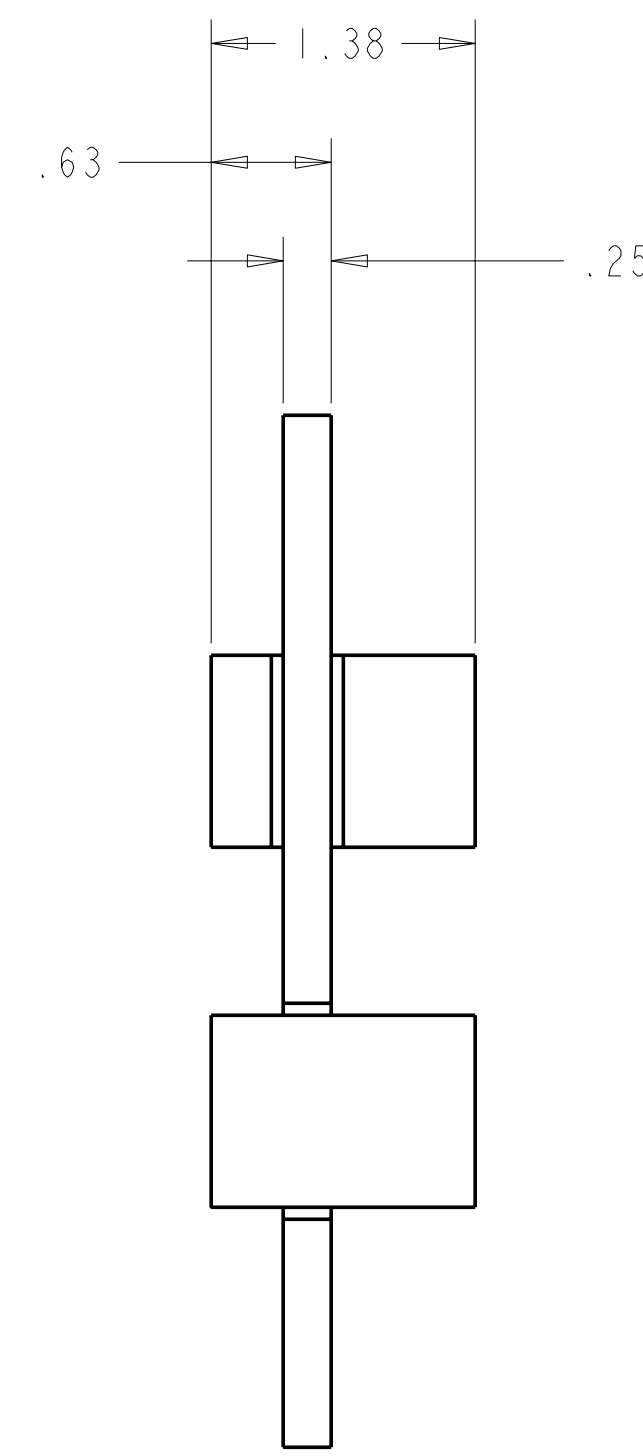
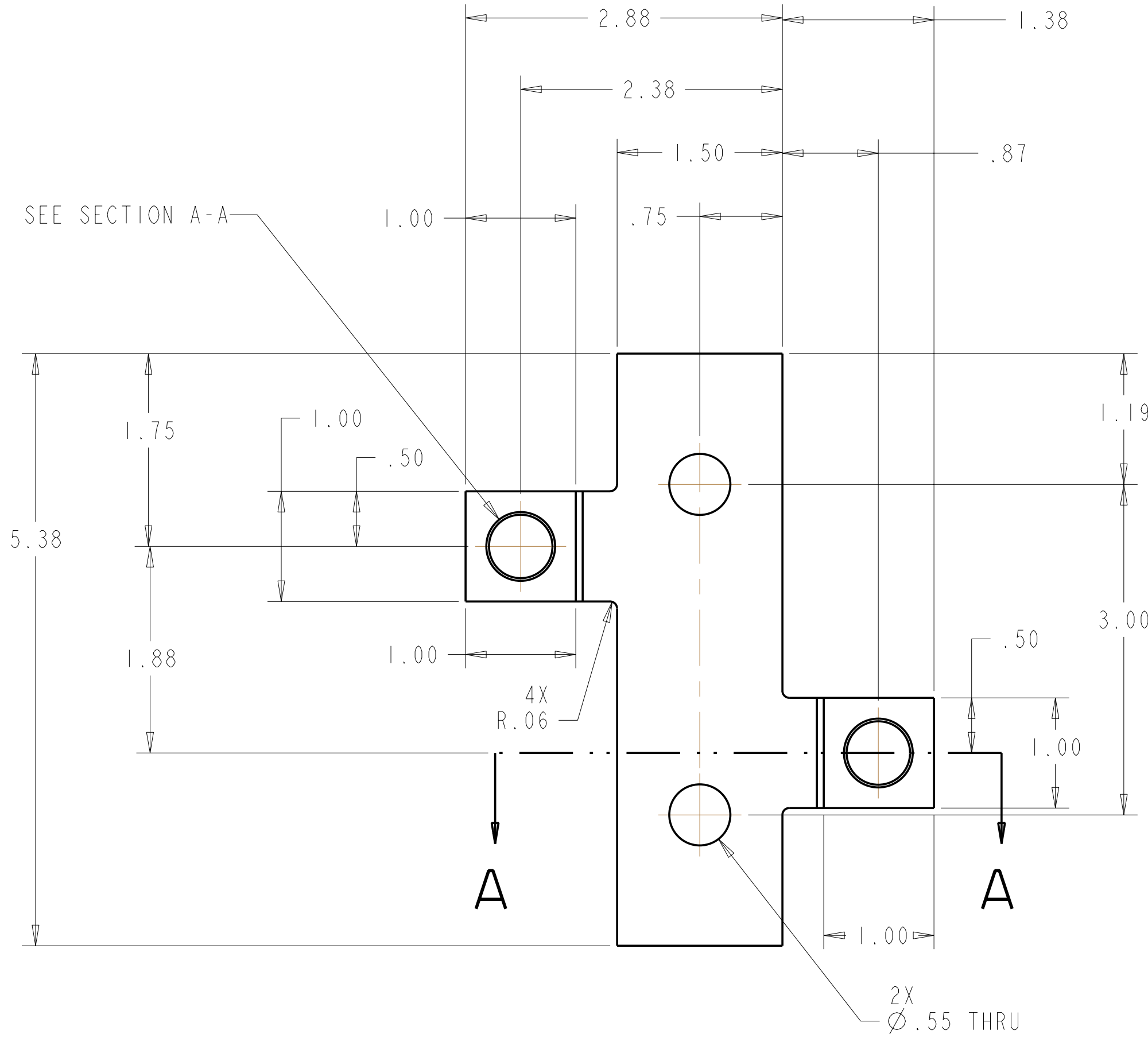
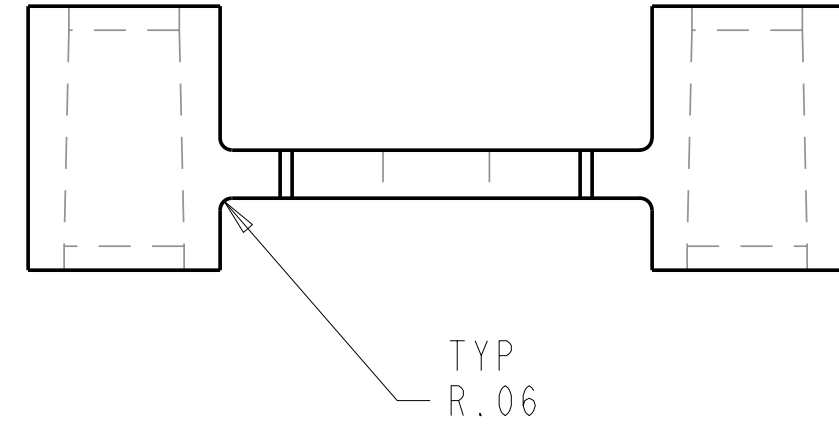

SECTION A-A  
SCALE 1:00  
TYPICAL 2 PLACES

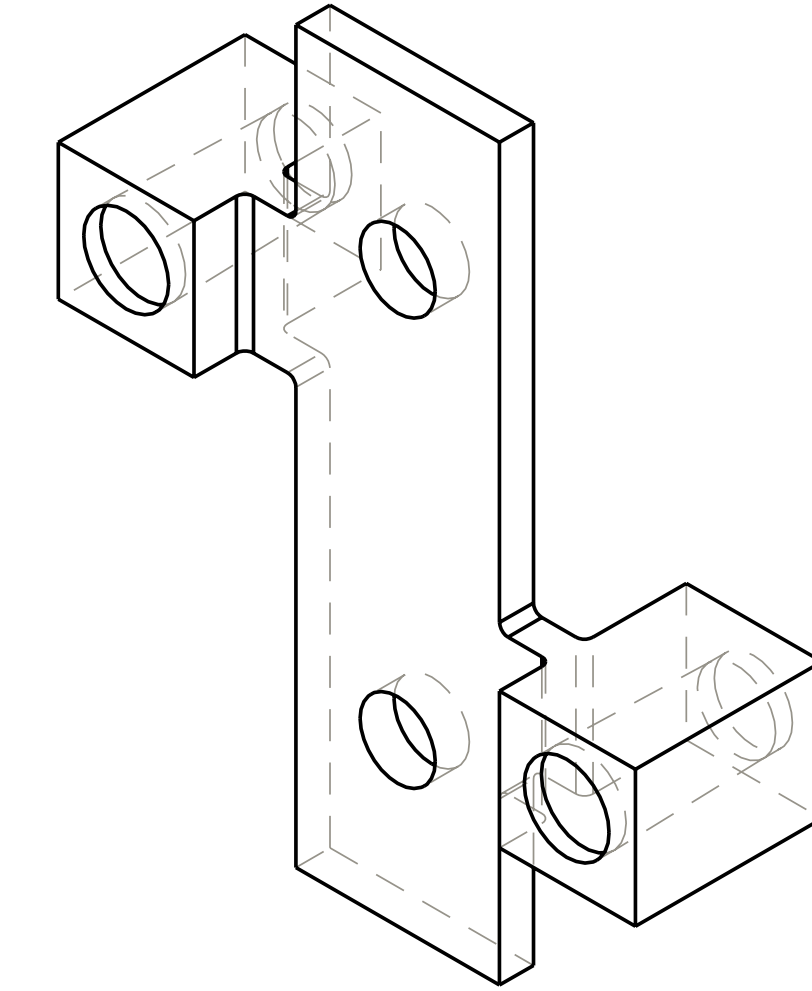

ISOMETRIC VIEW

I

next assy	AR	-1	JUMPER 2	COPPER 7	SEE NOTE 6	1
SE1406-010	CAGE CODE	PART OR IDENTIFYING NO	NOMENCLATURE OR DESCRIPTION	MATERIAL	SPECIFICATION	FIND NO
			NEXT ASSEMBLY	PARTS LIST		

NO REPRESENTATION OR WARRANTY, EXPRESSED OR IMPLIED, IS MADE AS TO THE ACCURACY, COMPLETENESS OR USEFULNESS OF THE INFORMATION OR STATEMENTS CONTAINED IN THESE DRAWINGS, OR THAT THE USE OR DISCLOSURE OF ANY INFORMATION, APPARATUS, METHOD OR PROCESS DISCLOSED IN THESE DRAWINGS MAY NOT INFRINGE PRIVATE RIGHTS OF OTHERS. NO LIABILITY IS ASSUMED WITH RESPECT TO THE USE OF, OR FOR DAMAGES RESULTING FROM THE USE OF, ANY INFORMATION, APPARATUS, METHOD OR PROCESS DISCLOSED IN THESE DRAWINGS. DRAWINGS MADE AVAILABLE FOR INFORMATION TO BIDDER ARE NOT TO BE USED FOR OTHER PURPOSES, AND ARE TO BE RETURNED UPON REQUEST OF THE FORWARDING CONTRACTOR.

**P** THIS DRAWING PRODUCED ON PRO-ENGINEER

REV	DESCRIPTION	BY	DATE	CHK	DEPT	DATE	PE	REQ	DATE	DRNL	DOE	DATE
REVISION OR ISSUE PURPOSE												

SCALE 1:1 UNO			DES PJ FOGARTY 8-12-04	<b>UT-BATTELLE</b> Oak Ridge National Laboratory managed for the DEPARTMENT OF ENERGY under U.S. GOVERNMENT contract DE-AC05-00OR22725 UT-BATTELLE, LLC. Oak Ridge, Tennessee <small>PROJECT NAME</small>
TOLERANCES UNLESS OTHERWISE SPECIFIED			DRW G LOVETT 8-12-04	
FRACTIONS ±.01			CHK G JONES 8-12-04	
XXX DECIMALS ±.005			PE D WILLIAMSON 8-12-04	
ANGLES ±0°15'			CR :	
BREAK SHARP EDGES .06 MAX			PJ :	
FINISH :25 UNLESS OTHERWISE SPECIFIED			RD :	
			PPPL DRFT :	
			PPPL DRFT :	
			PPPL DRFT :	
			PPPL DRFT :	
			PPPL DRFT :	
VERSION NO. 0				PLANT X-10
RELEASE LEVEL WIP				BLDG 5700
DATE				FL 3
				SHT 1
				OF 1
				TYPE I
				CLASS S
				REV U
				0
			DATE	SE1406-052

B SE1406-052

- NOTES:
1. INTERPRET DIMENSIONS AND TOLERANCES PER ANSI Y14.5M
  2. DIMENSIONS ARE IN INCHES
  3. DIMENSIONS APPLY AT ROOM TEMPERATURE. OPERATING TEMP 80 K.
  4. GEOMETRY IS DEFINED IN PRO ENGINEER CAD MODELS/FILES SEI406-053.PRT
  5. DRAWING AND MODELS COMBINED DEFINE FINISHED MACHINED PART.
  6. SEE SPECIFICATION, NCSX-CSPEC 141-02-00 FOR ADDITIONAL REQUIREMENTS.
  7. SEE SPECIFICATION NCSX-CSPEC 141-02-00 SECTION 3.2.1.1 FOR MATERIAL REQUIREMENTS.

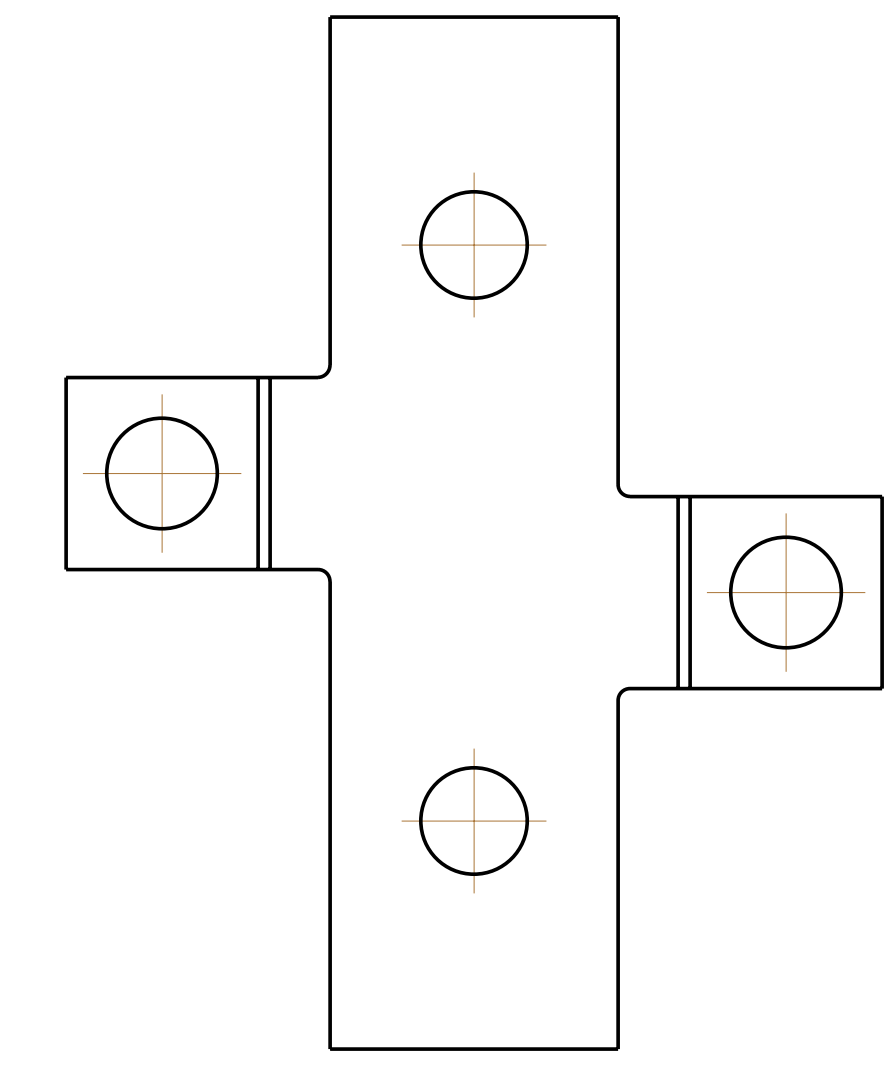
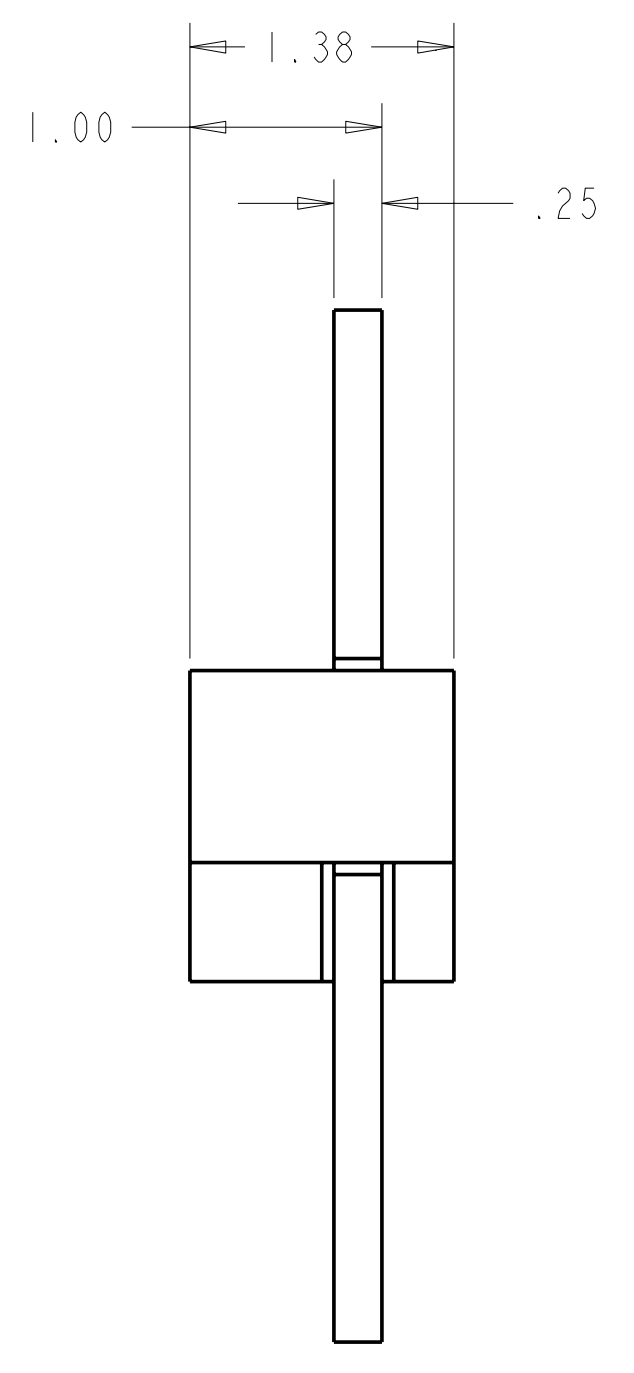
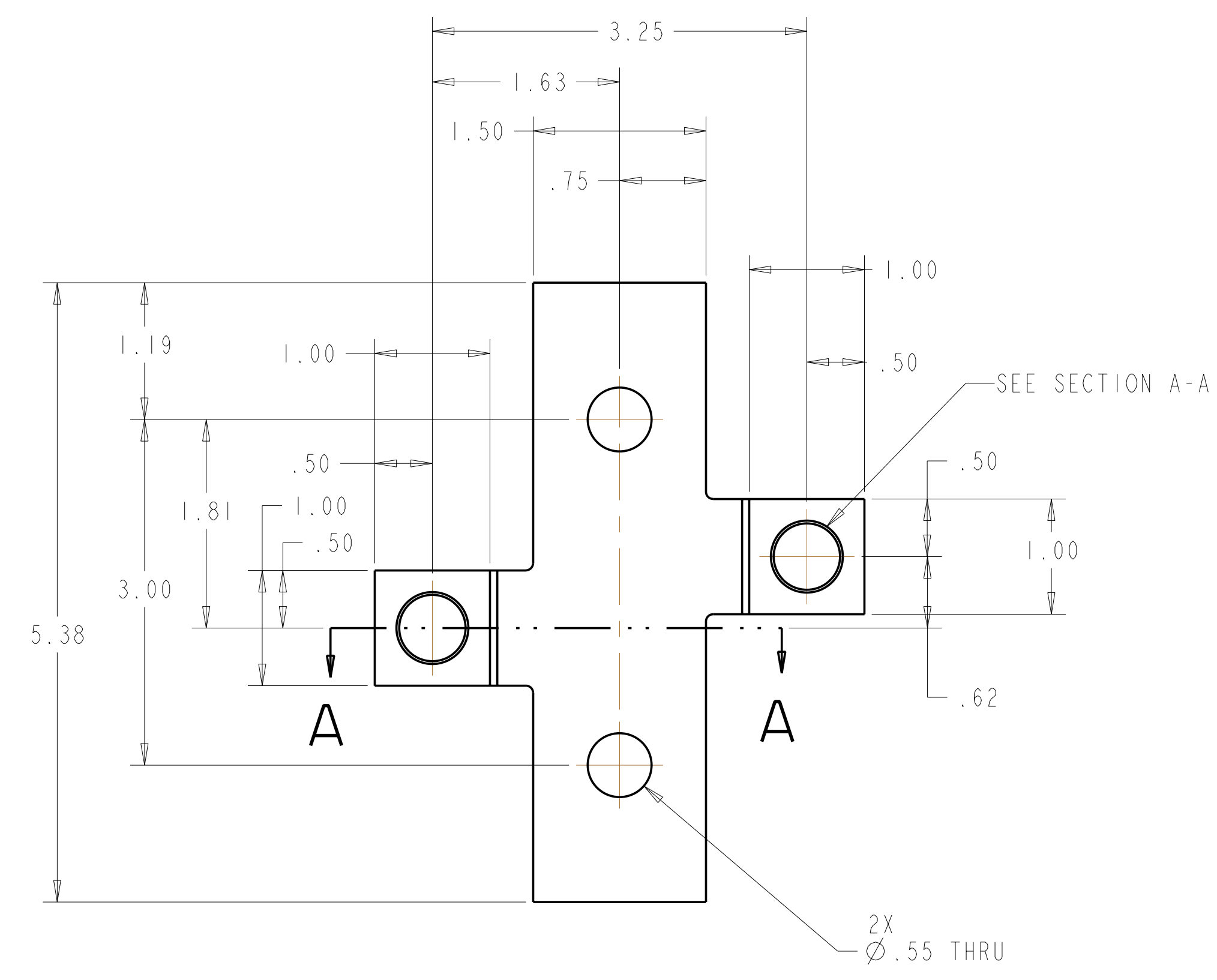
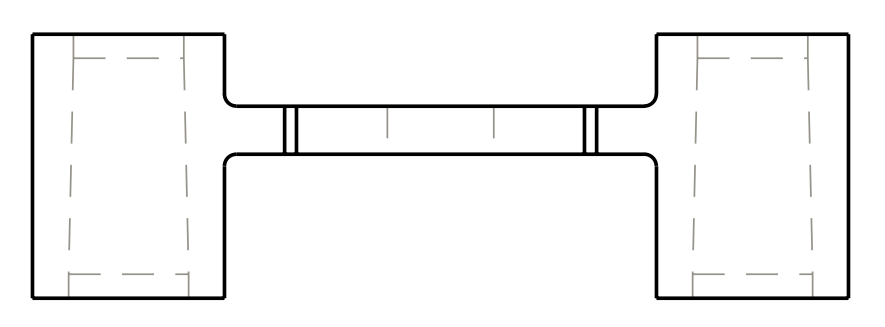

1

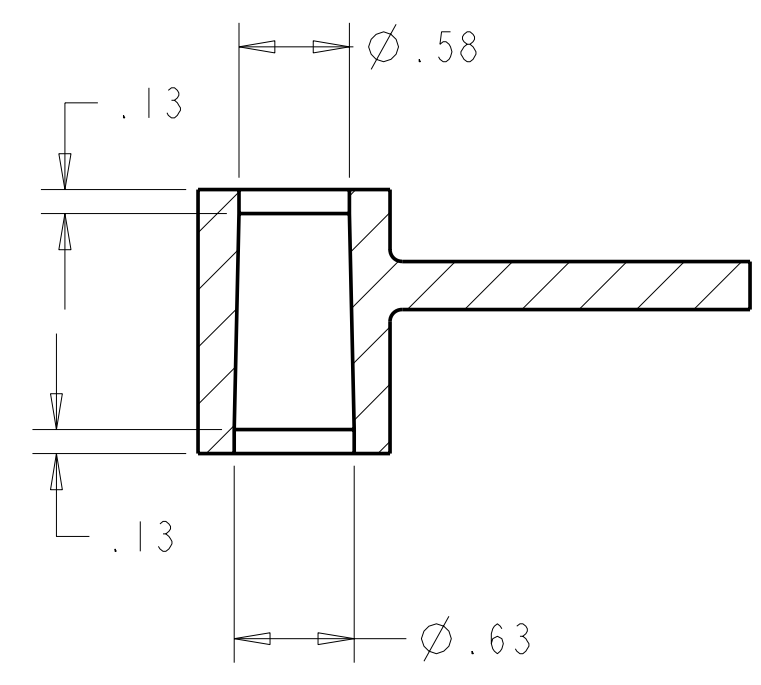

SECTION A-A  
 SCALE 1:1.00  
 TYPICAL 2 PLACES

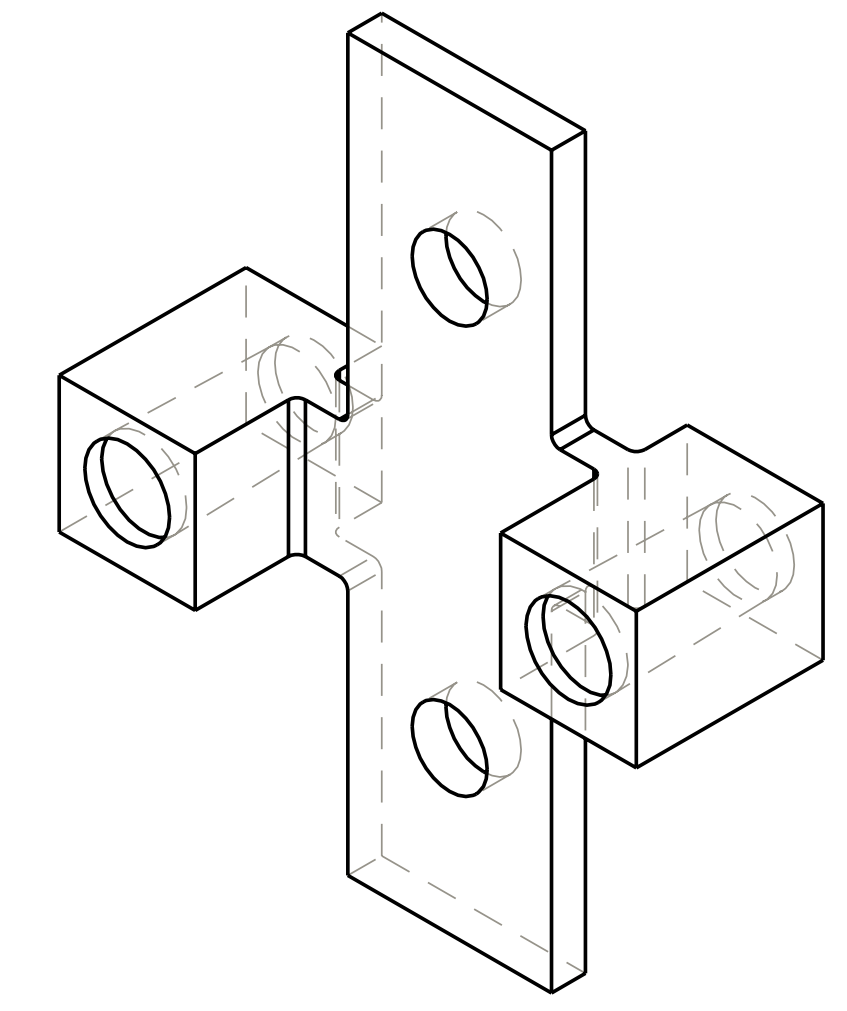

ISOMETRIC VIEW

next assy	AR	-1	JUMPER 3	COPPER 7	SEE NOTE 6	1
SEI406-010	CAGE CODE	PART OR IDENTIFYING NO	NOMENCLATURE OR DESCRIPTION	MATERIAL	SPECIFICATION	FIND NO
		NEXT ASSEMBLY	PARTS LIST			

NO REPRESENTATION OR WARRANTY, EXPRESSED OR IMPLIED, IS MADE AS TO THE ACCURACY, COMPLETENESS OR USEFULNESS OF THE INFORMATION OR STATEMENTS CONTAINED IN THESE DRAWINGS, OR THAT THE USE OR DISCLOSURE OF ANY INFORMATION, APPARATUS, METHOD OR PROCESS DISCLOSED IN THESE DRAWINGS MAY NOT INFRINGE PRIVATE RIGHTS OF OTHERS. NO LIABILITY IS ASSUMED WITH RESPECT TO THE USE OF, OR FOR DAMAGES RESULTING FROM THE USE OF, ANY INFORMATION, APPARATUS, METHOD OR PROCESS DISCLOSED IN THESE DRAWINGS. DRAWINGS MADE AVAILABLE FOR INFORMATION TO BIDDER ARE NOT TO BE USED FOR OTHER PURPOSES, AND ARE TO BE RETURNED UPON REQUEST OF THE FORWARDING CONTRACTOR.

**P** THIS DRAWING PRODUCED ON PRO-ENGINEER

REV	DESCRIPTION	BY	DATE	CHK	DEPT	DATE	PE	REQ	DATE	ORNL	DOE	DATE

SCALE 1:1 UNO	DES PJ FOGARTY	8-12-04
TOLERANCES UNLESS OTHERWISE SPECIFIED	DRW G LOVETT	8-12-04
FRACTIONS	CHK G JONES	8-12-04
XX DECIMALS ±.01	SECT :	
XXX DECIMALS ±.005	DEPT :	
ANGLES ±0°15'	PE D WILLIAMSON	8-12-04
BREAK SHARP EDGES 06 MAX	CR :	
FINISH .125 UNLESS OTHERWISE SPECIFIED	PJ :	
	RED :	
	PPPL DRFT :	

Oak Ridge National Laboratory managed for the DEPARTMENT OF ENERGY under U.S. GOVERNMENT contract DE-AC05-00OR22725 UT-BATTELLE, LLC, Oak Ridge, Tennessee PRODUCT NAME <b>NATIONAL COMPACT STELLARATOR EXPERIMENT</b>							
<b>JUMPER 3</b>							
VERSION NO.	PLANT	BLDG	FL	SHT OF	TYPE	CLASS	
0	X-10	5700	3	1	I	S	U
RELEASE LEVEL	SEI406-053					REV	0
WIP							

H  
G  
F  
E  
D  
C  
B  
A

H  
G  
F  
E  
D  
C  
B  
A

- NOTES:
1. INTERPRET DIMENSIONS AND TOLERANCES PER ANSI Y14.5M
  2. DIMENSIONS ARE IN INCHES
  3. DIMENSIONS APPLY AT ROOM TEMPERATURE. OPERATING TEMP 80 K.
  4. GEOMETRY IS DEFINED IN PRO ENGINEER CAD MODELS/FILES SE1406-054.PRT
  5. DRAWING AND MODELS COMBINED DEFINE FINISHED MACHINED PART.
  6. SEE SPECIFICATION, NCSX-CSPEC 141-02-00 FOR ADDITIONAL REQUIREMENTS.
  7. SEE SPECIFICATION NCSX-CSPEC 141-02-00 SECTION 3.2.1.1 FOR MATERIAL REQUIREMENTS.

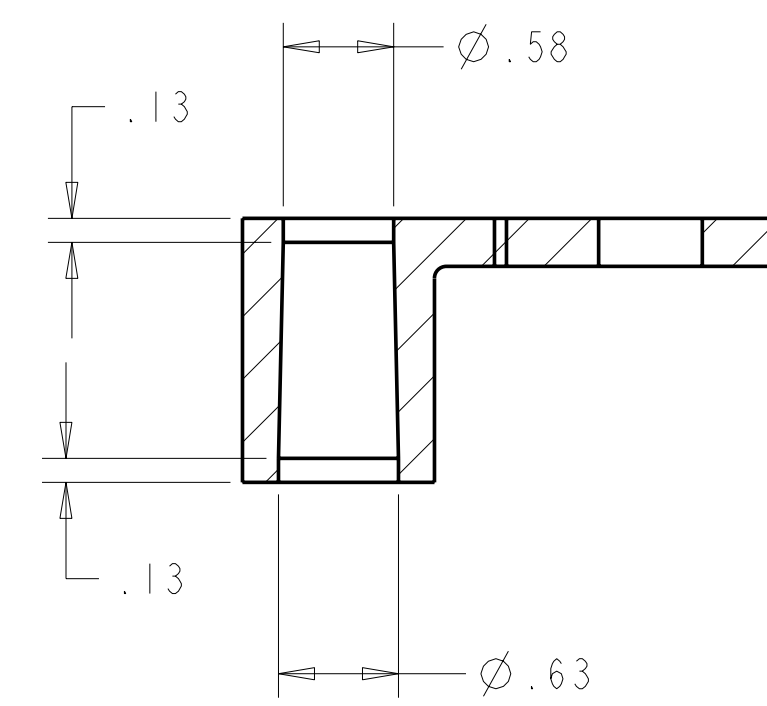
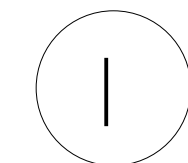
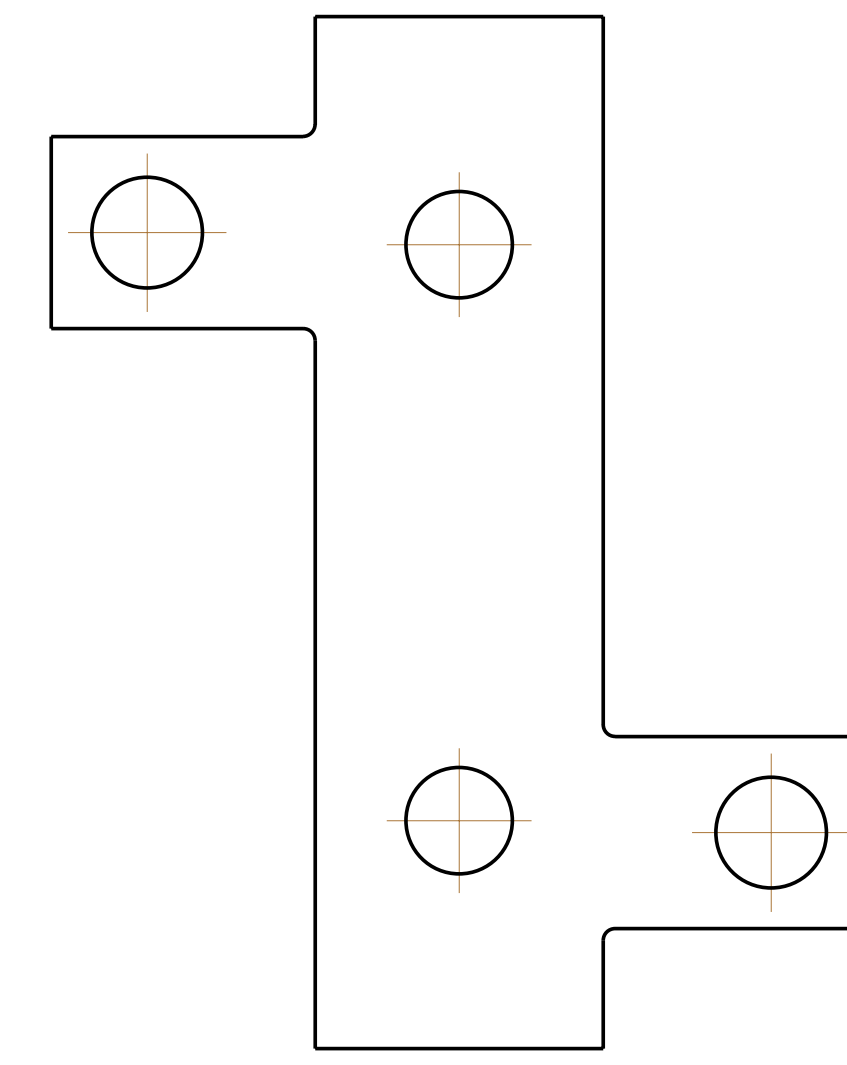
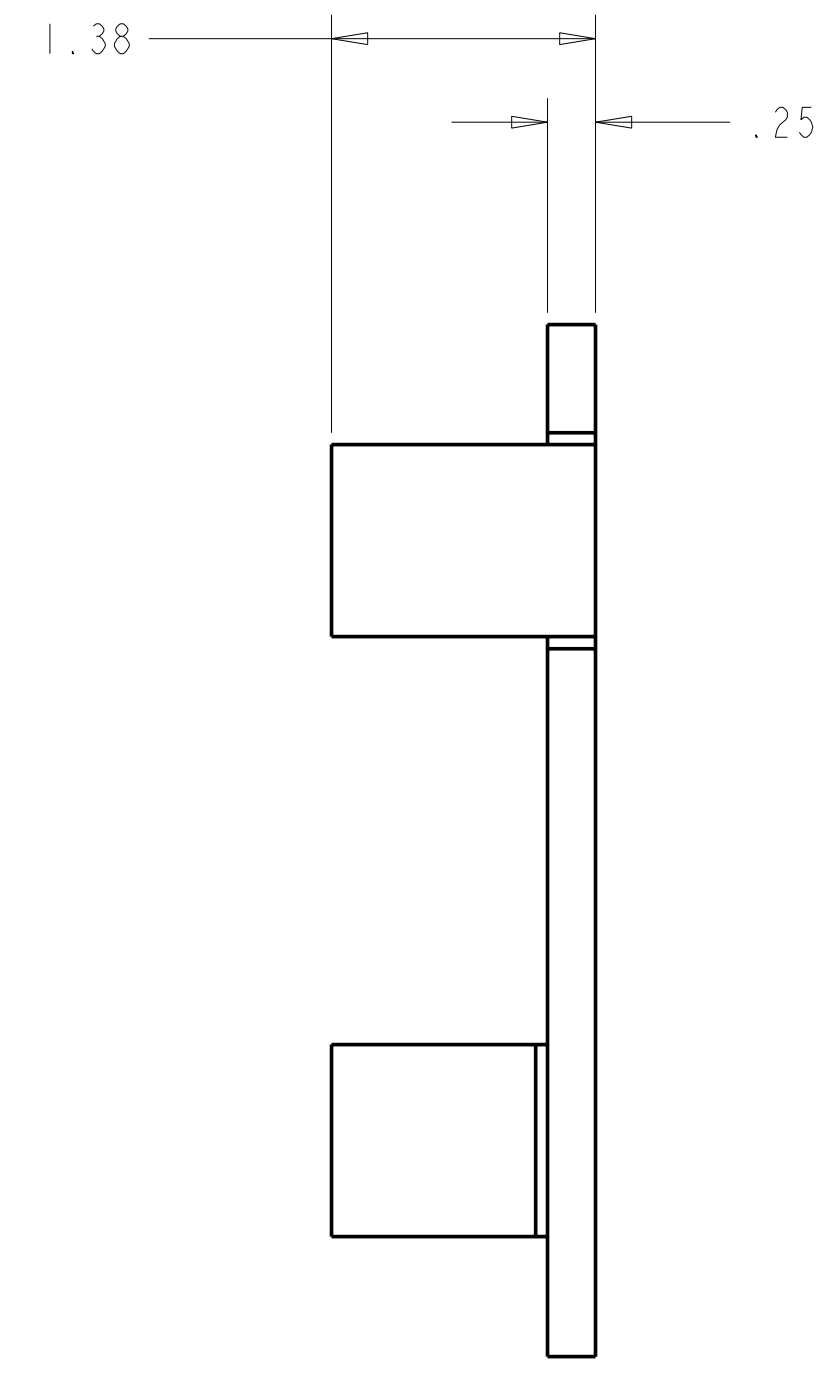
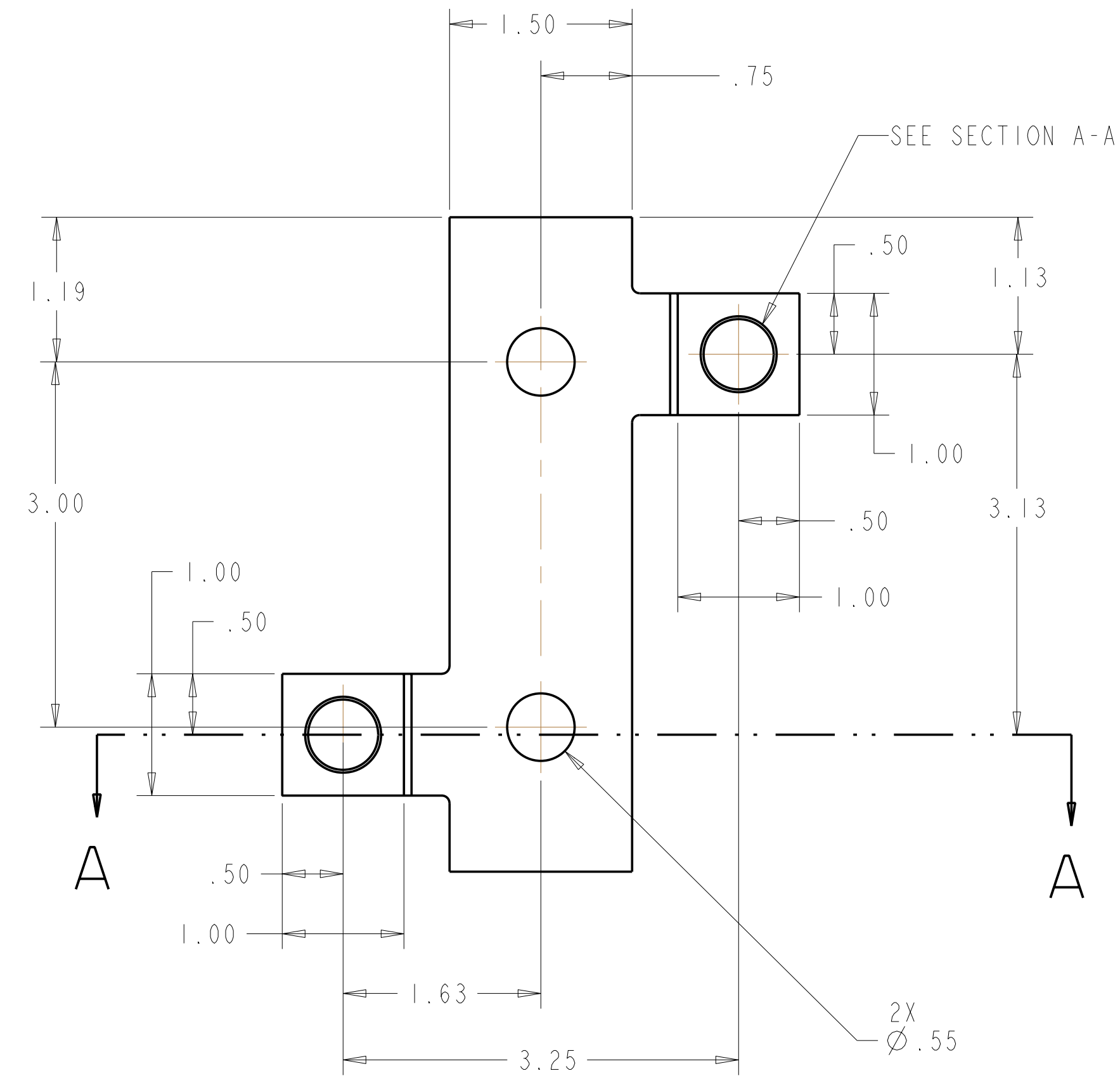
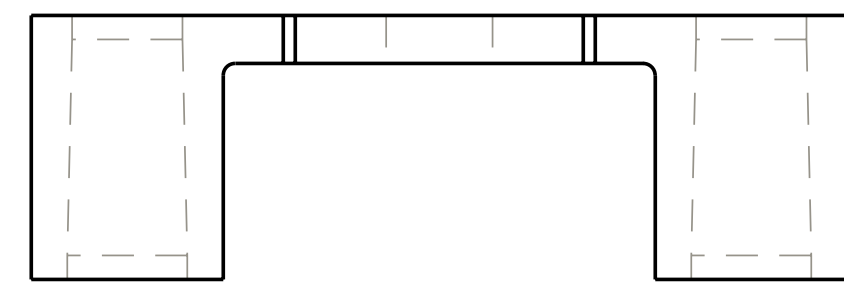

SECTION A-A  
 SCALE 1.00

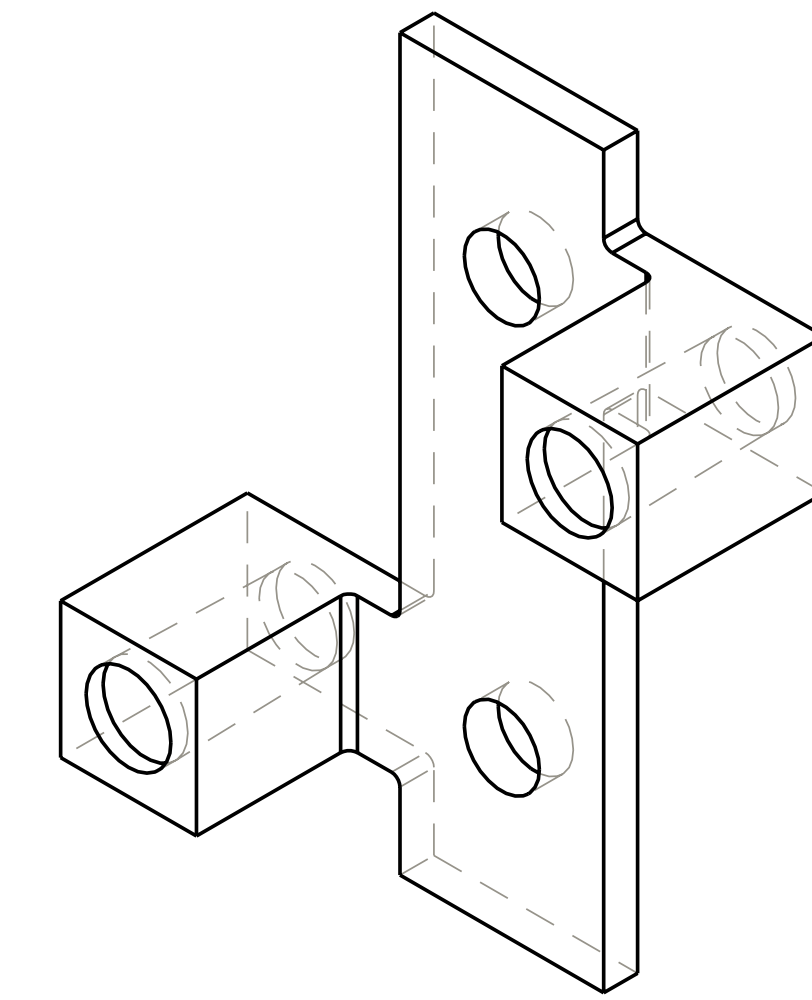

ISOMETRIC VIEW

next assy	AR	-1	JUMPER 4	COPPER 7	SEE NOTE 6	I
SE1406-010	CAGE CODE	PART OR IDENTIFYING NO	NOMENCLATURE OR DESCRIPTION	MATERIAL	SPECIFICATION	FIND NO
		NEXT ASSEMBLY	PARTS LIST			

NO REPRESENTATION OR WARRANTY, EXPRESSED OR IMPLIED, IS MADE AS TO THE ACCURACY, COMPLETENESS OR USEFULNESS OF THE INFORMATION OR STATEMENTS CONTAINED IN THESE DRAWINGS, OR THAT THE USE OR DISCLOSURE OF ANY INFORMATION, APPARATUS, METHOD OR PROCESS DISCLOSED IN THESE DRAWINGS MAY NOT INFRINGE PRIVATE RIGHTS OF OTHERS. NO LIABILITY IS ASSUMED WITH RESPECT TO THE USE OF, OR FOR DAMAGES RESULTING FROM THE USE OF, ANY INFORMATION, APPARATUS, METHOD OR PROCESS DISCLOSED IN THESE DRAWINGS. DRAWINGS MADE AVAILABLE FOR INFORMATION TO BIDDER ARE NOT TO BE USED FOR OTHER PURPOSES, AND ARE TO BE RETURNED UPON REQUEST OF THE FORWARDING CONTRACTOR.

**P** THIS DRAWING PRODUCED ON PRO-ENGINEER

REV	DESCRIPTION	BY	DATE	CHK	DEPT	DATE	PE	REQ	DATE	ORNL	DOE	DATE

SCALE 1:1 UNO	DES PJ FOGARTY 8-12-04	<b>UT-BATTELLE</b> Oak Ridge National Laboratory managed for the DEPARTMENT OF ENERGY under U.S. GOVERNMENT contract DE-AC05-00OR22725 UT-BATTELLE, LLC, Oak Ridge, Tennessee PRODUCT NAME <b>NATIONAL COMPACT STELLARATOR EXPERIMENT</b>
TOLERANCES UNLESS OTHERWISE SPECIFIED	DRW G LOVETT 8-12-04	
FRACTIONS	CHK :	
XX DECIMALS ±.01	PE D WILLIAMSON 8-12-04	
XXX DECIMALS ±.005	CR :	VERSION NO. 0
ANGLES ±0°15'	PJ :	PLANT X-10
BREAK SHARP EDGES .06 MAX	REG :	BLDG 5700
FINISH .125 UNLESS OTHERWISE SPECIFIED	REP :	FL 3
	PPPL DRFT :	SHT OF 1
		TYPE I
		CLASS U
		REV 0
		RELEASE LEVEL WIP
		SE1406-054

H  
G  
F  
E  
D  
C  
B  
A

SE1406-054

8

7

6

5

4

3

2

1

NEXT ASS'Y: 1 FINAL ASS'Y:

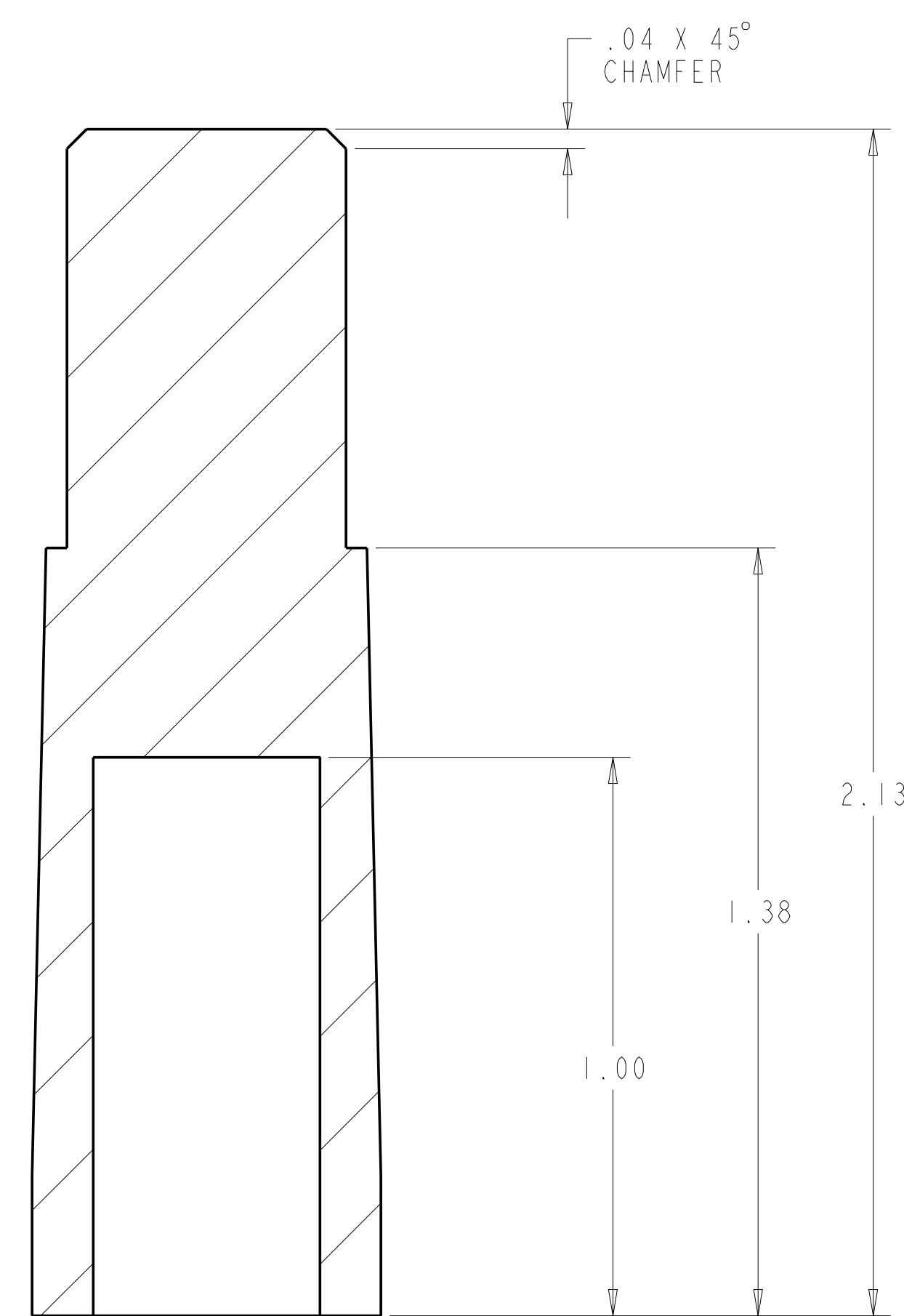

SECTION A-A

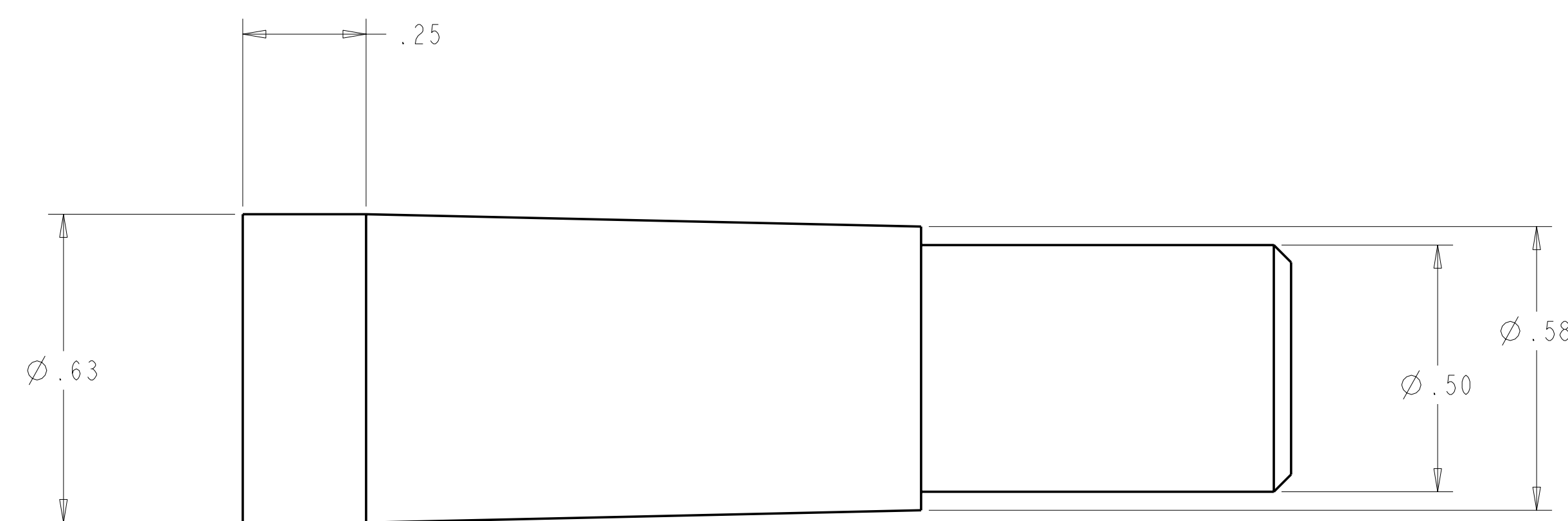
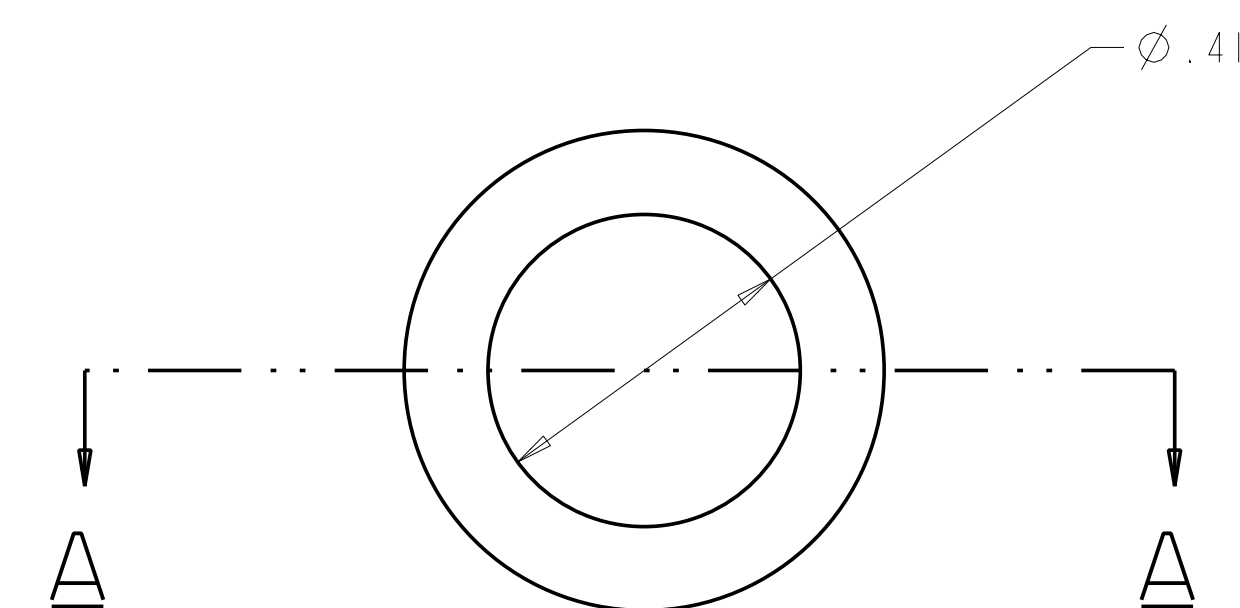

NOTES:

1. INTERPRET DIMENSIONS AND TOLERANCES PER ANSI Y14.5M
2. DIMENSIONS ARE IN INCHES
3. DIMENSIONS APPLY AT ROOM TEMPERATURE. OPERATING TEMP 80 K.
4. GEOMETRY IS DEFINED IN PRO ENGINEER CAD MODELS/FILES SE1406-055.PRT
5. DRAWING AND MODELS COMBINED DEFINE FINISHED MACHINED PART.
6. SEE SPECIFICATION, NCSX-CSPEC 141-02-00 FOR ADDITIONAL REQUIREMENTS.
7. SEE SPECIFICATION NCSX-CSPEC 141-02-00 SECTION 3.2.1.1 FOR MATERIAL REQUIREMENTS.

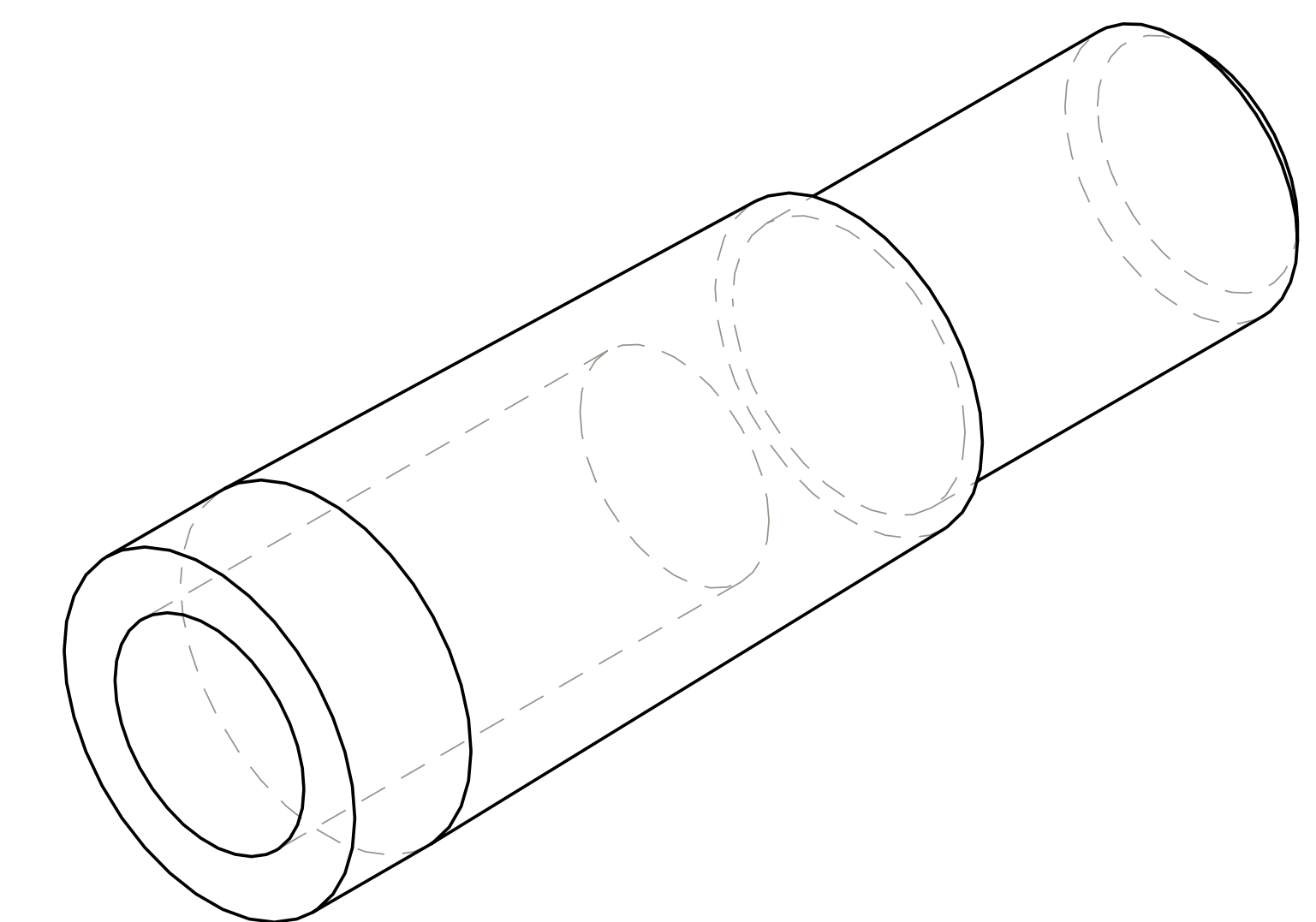

ISOMETRIC VIEW

next assy	AR	-1	INSULATOR	G10	SEE NOTE	I
	SE1406-010	IDENTIFYING NO	NOMENCLATURE OR DESCRIPTION	MATERIAL	SPECIFICATION	FIND NO
NEXT ASSEMBLY			PARTS LIST			

NO REPRESENTATION OR WARRANTY, EXPRESSED OR IMPLIED, IS MADE AS TO THE ACCURACY, COMPLETENESS OR USEFULNESS OF THE INFORMATION OR STATEMENTS CONTAINED IN THESE DRAWINGS, OR THAT THE USE OR DISCLOSURE OF ANY INFORMATION, APPARATUS, METHOD OR PROCESS DISCLOSED IN THESE DRAWINGS MAY NOT INFRINGE PRIVATE RIGHTS OF OTHERS. NO LIABILITY IS ASSUMED WITH RESPECT TO THE USE OF, OR FOR DAMAGES RESULTING FROM THE USE OF, ANY INFORMATION, APPARATUS, METHOD OR PROCESS DISCLOSED IN THESE DRAWINGS. DRAWINGS MADE AVAILABLE FOR INFORMATION TO BIDDER ARE NOT TO BE USED FOR OTHER PURPOSES, AND ARE TO BE RETURNED UPON REQUEST OF THE FORWARDING CONTRACTOR.

**P** THIS DRAWING PRODUCED ON PRO-ENGINEER

REV	DESCRIPTION	BY	DATE	CHK	DEPT	DATE	PE	REQ	DATE	DRNL	DOE	DATE

SCALE 4:1 UNO		DES PJ FOGARTY 8-13-04
TOLERANCES UNLESS OTHERWISE SPECIFIED		DRW G LOVETT 8-13-04
FRACTIONS ±.01		CHK G JONES 8-13-04
XXX DECIMALS ±.005		DEPT :
ANGLES ±0°15'		PE D WILLIAMSON 8-13-04
BREAK SHARP EDGES .06 MAX		CR :
FINISH .125 UNLESS OTHERWISE SPECIFIED		PJ :
		RD :
		PPPL DRFT :

<b>UT-BATTELLE</b> <small>Oak Ridge National Laboratory          managed for the DEPARTMENT OF ENERGY under          U.S. GOVERNMENT contract DE-AC05-00OR22725          UT-BATTELLE, LLC, Oak Ridge, Tennessee</small>	
<b>NATIONAL COMPACT STELLARATOR EXPERIMENT</b>	
<b>INSULATOR</b>	
VERSION NO.	0
PLANT	X-10
BLDG	5700
FL	3
SHT OF	1
TYPE	ISU
CLASS	U
RELEASE LEVEL	WIP
REV	0

SE1406-055

A

- NOTES:
1. INTERPRET DIMENSIONS AND TOLERANCES PER ANSI Y14.5M
  2. DIMENSIONS ARE IN INCHES
  3. DIMENSIONS APPLY AT ROOM TEMPERATURE. OPERATING TEMP 80 K.
  4. GEOMETRY IS DEFINED IN PRO ENGINEER CAD MODELS/FILES SE1406-056.PRT
  5. DRAWING AND MODELS COMBINED DEFINE FINISHED MACHINED PART.
  6. SEE SPECIFICATION, NCSX-CSPEC 141-02-00 FOR ADDITIONAL REQUIREMENTS.
  7. SEE SPECIFICATION NCSX-CSPEC 141-02-00 SECTION 3.2.1.1 FOR MATERIAL REQUIREMENTS.)

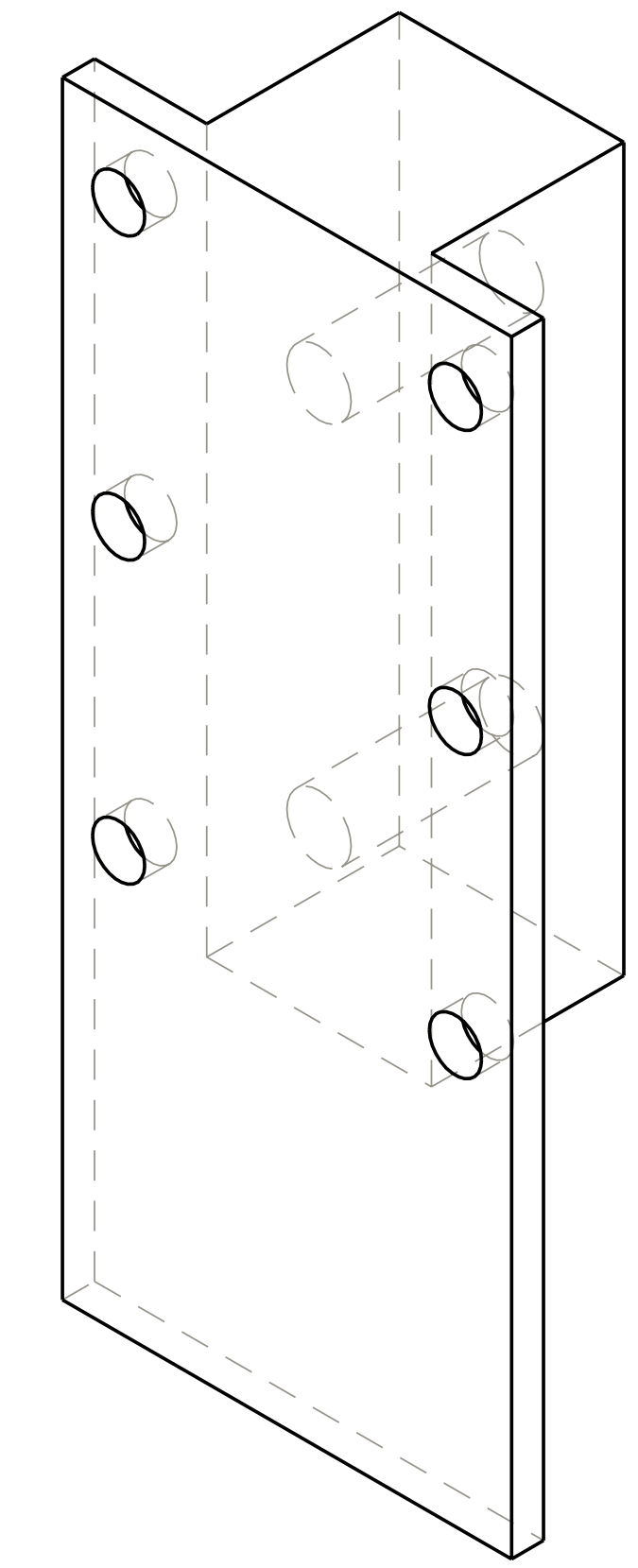
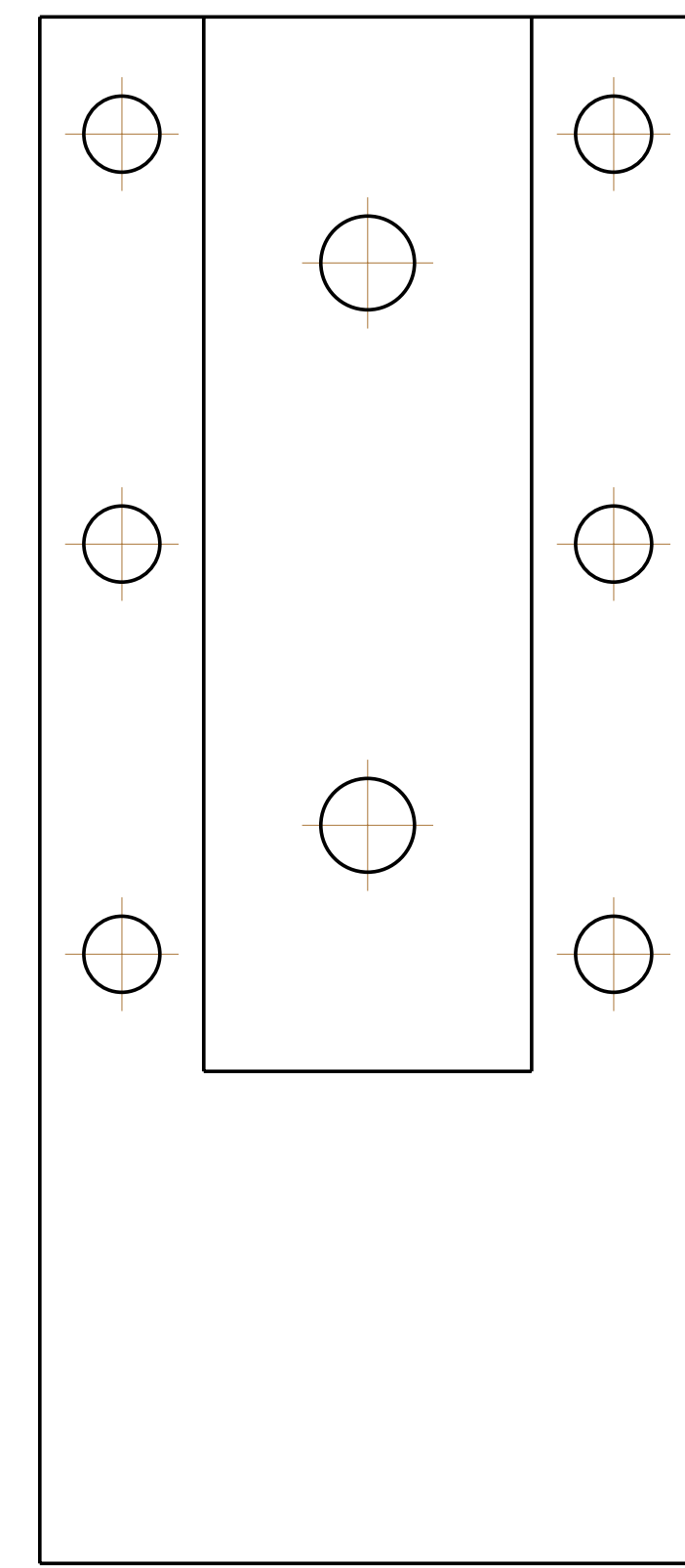
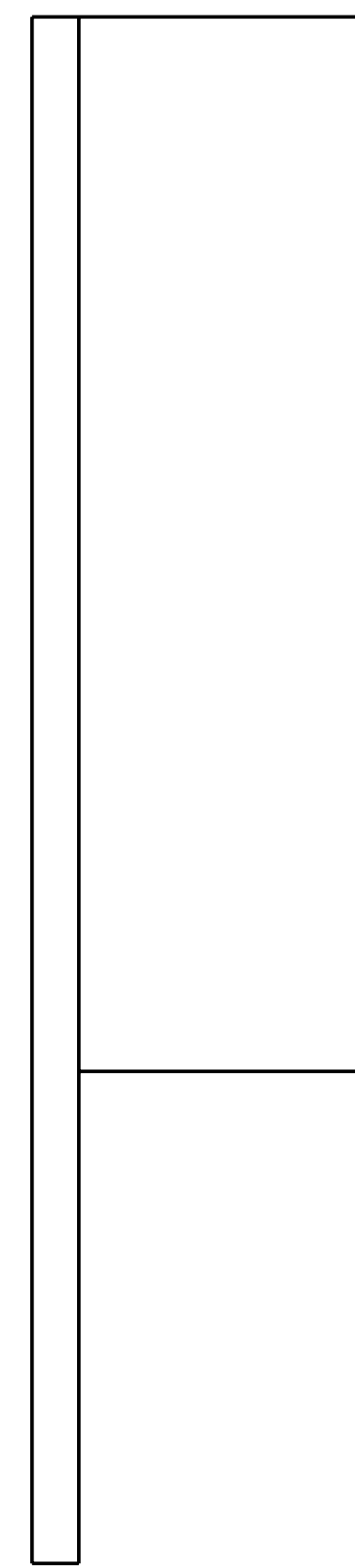
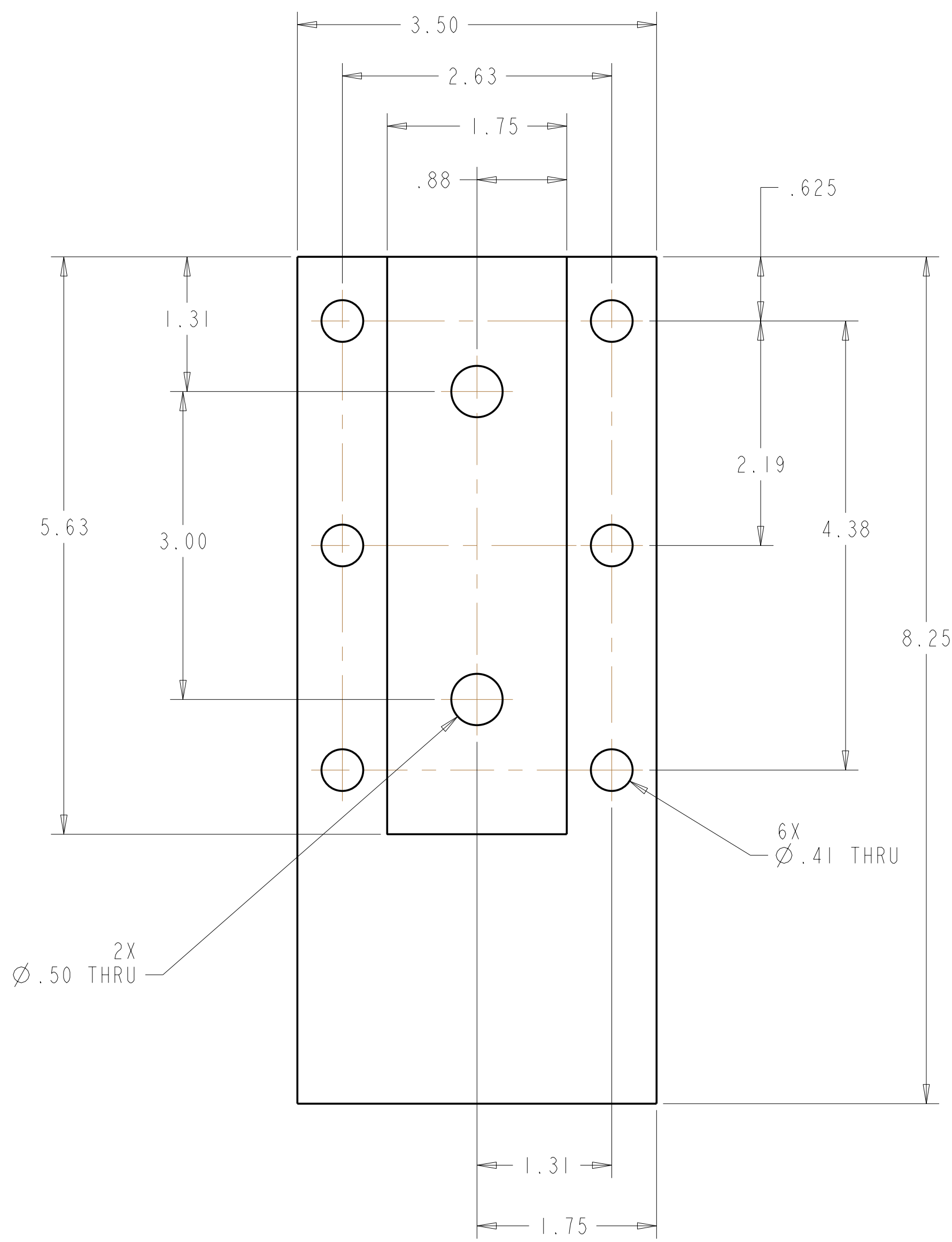
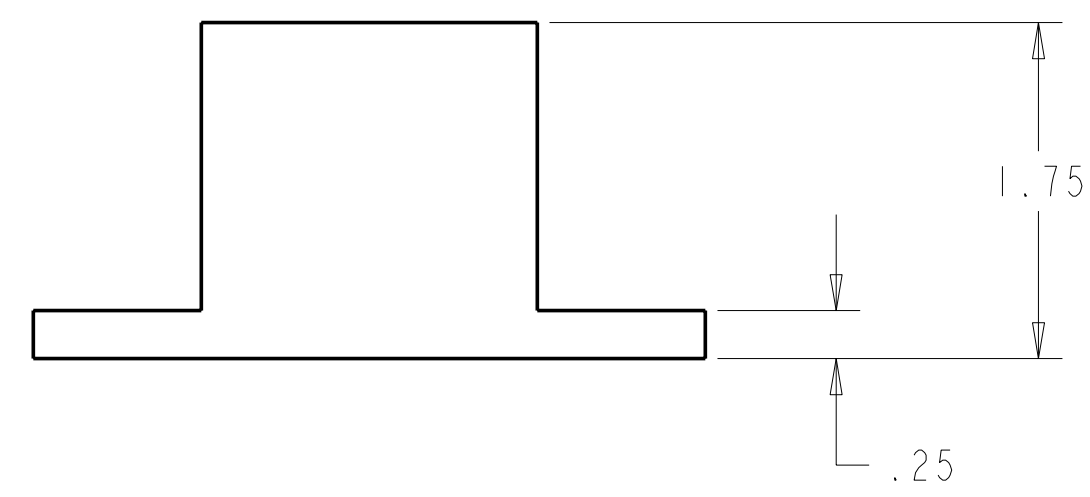

ISOMETRIC VIEW

next assy	AR	-1	TERMINAL LUG IN	COPPER 7	SEE NOTE 6	I
SE1406-010	CAGE CODE	PART OR IDENTIFYING NO	NOMENCLATURE OR DESCRIPTION	MATERIAL	SPECIFICATION	FIND NO
		NEXT ASSEMBLY	PARTS LIST			

SCALE 1:1 UNO										DES: PJ FOGARTY 8-13-04		Oak Ridge National Laboratory managed for the DEPARTMENT OF ENERGY under U.S. GOVERNMENT contract DE-AC05-00OR22725 UT-BATTELLE, LLC. Oak Ridge, Tennessee			
TOLERANCES UNLESS OTHERWISE SPECIFIED										DRW: G LOVETT 8-13-04		UT-BATTELLE			
FRACTIONS ±.01										CHK: G JONES 8-13-04		NATIONAL COMPACT STELLARATOR EXPERIMENT			
XX DECIMALS ±.005										SECT: :		TERMINAL LUG IN			
XXX DECIMALS ±.001										DEPT: :		VERSION NO. 0			
ANGLES ±0°15'										PE: D WILLIAMSON 8-13-04		PLANT X-10			
BREAK SHARP EDGES .06 MAX										CR: :		BLDG 5700			
FINISH .125 UNLESS OTHERWISE SPECIFIED										PJ: :		FL 3			
										RD: :		SHT OF 1			
										PPPL DRFT :		TYPE I S			
										:		CLASS U			
										:		REV 0			
										DRAWING APPROVALS DATE		RELEASE LEVEL WIP			
												SE1406-056			

NO REPRESENTATION OR WARRANTY, EXPRESSED OR IMPLIED, IS MADE AS TO THE ACCURACY, COMPLETENESS OR USEFULNESS OF THE INFORMATION OR STATEMENTS CONTAINED IN THESE DRAWINGS, OR THAT THE USE OR DISCLOSURE OF ANY INFORMATION, APPARATUS, METHOD OR PROCESS DISCLOSED IN THESE DRAWINGS MAY NOT INFRINGE PRIVATE RIGHTS OF OTHERS. NO LIABILITY IS ASSUMED WITH RESPECT TO THE USE OF, OR FOR DAMAGES RESULTING FROM THE USE OF, ANY INFORMATION, APPARATUS, METHOD OR PROCESS DISCLOSED IN THESE DRAWINGS. DRAWINGS MADE AVAILABLE FOR INFORMATION TO BIDDER ARE NOT TO BE USED FOR OTHER PURPOSES, AND ARE TO BE RETURNED UPON REQUEST OF THE FORWARDING CONTRACTOR.

**P** THIS DRAWING PRODUCED ON PRO-ENGINEER

H  
G  
F  
E  
D  
C  
B  
A

SE1406-056



- NOTES:  
 1. INTERPRET DIMENSIONS AND TOLERANCES PER ANSI Y14.5M  
 2. DIMENSIONS ARE IN INCHES  
 3. DIMENSIONS APPLY AT ROOM TEMPERATURE. OPERATING TEMP 80 K.  
 4. GEOMETRY IS DEFINED IN PRO ENGINEER CAD MODELS/FILES SE1406-057.PRT  
 5. DRAWING AND MODELS COMBINED DEFINE FINISHED MACHINED PART.  
 6. SEE SPECIFICATION, NCSX-CSPEC 141-02-00 FOR ADDITIONAL REQUIREMENTS.  
 7. SEE SPECIFICATION NCSX-CSPEC 141-02-00 SECTION 3.2.1.1 FOR MATERIAL REQUIREMENTS.1

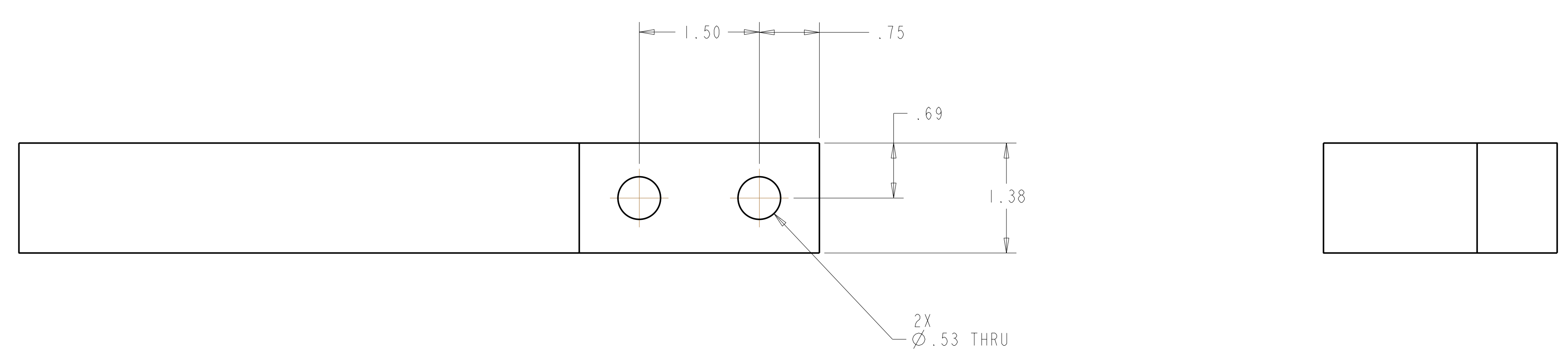
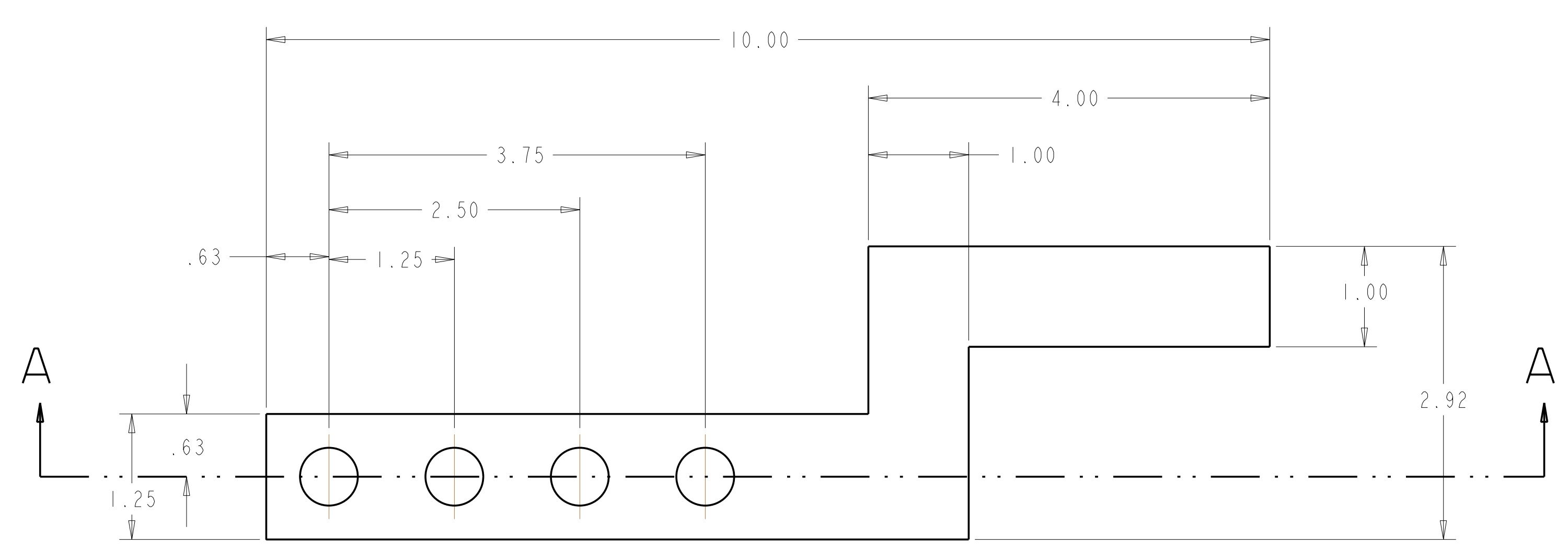

1

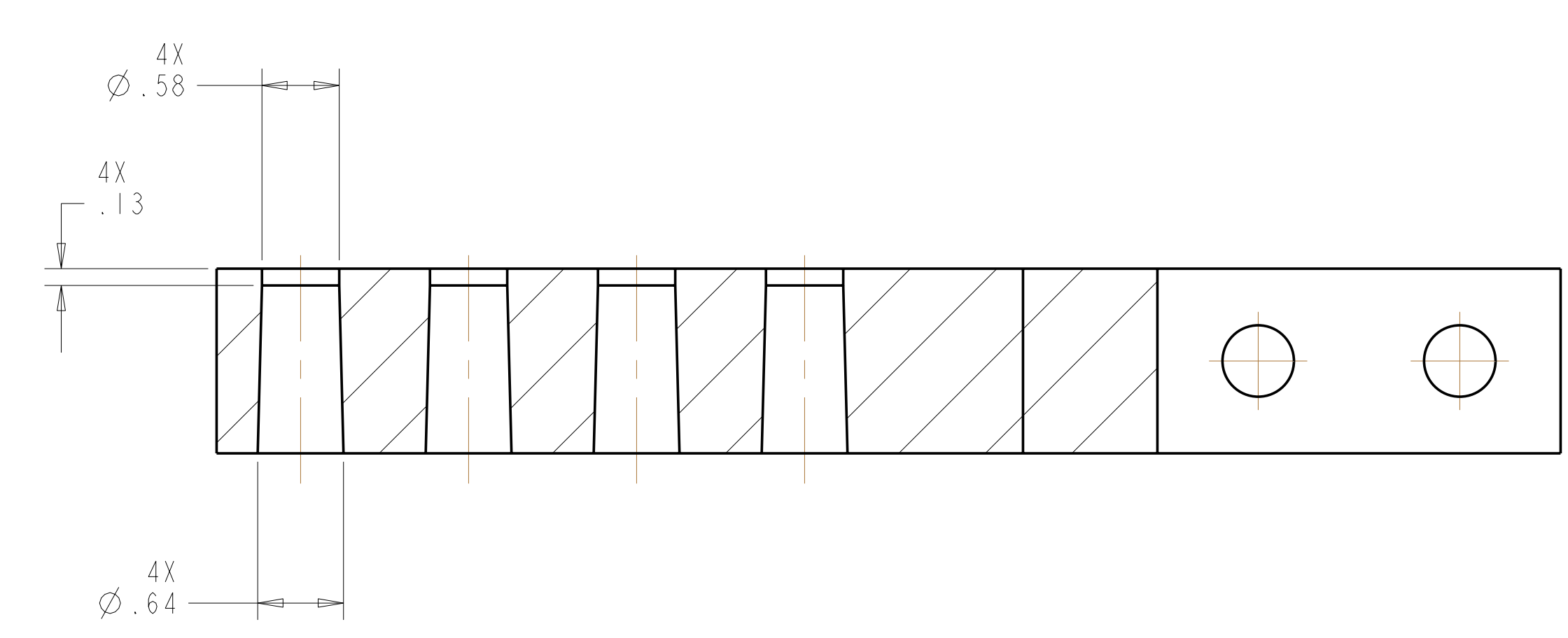

SECTION A-A  
 SCALE 1:1.00

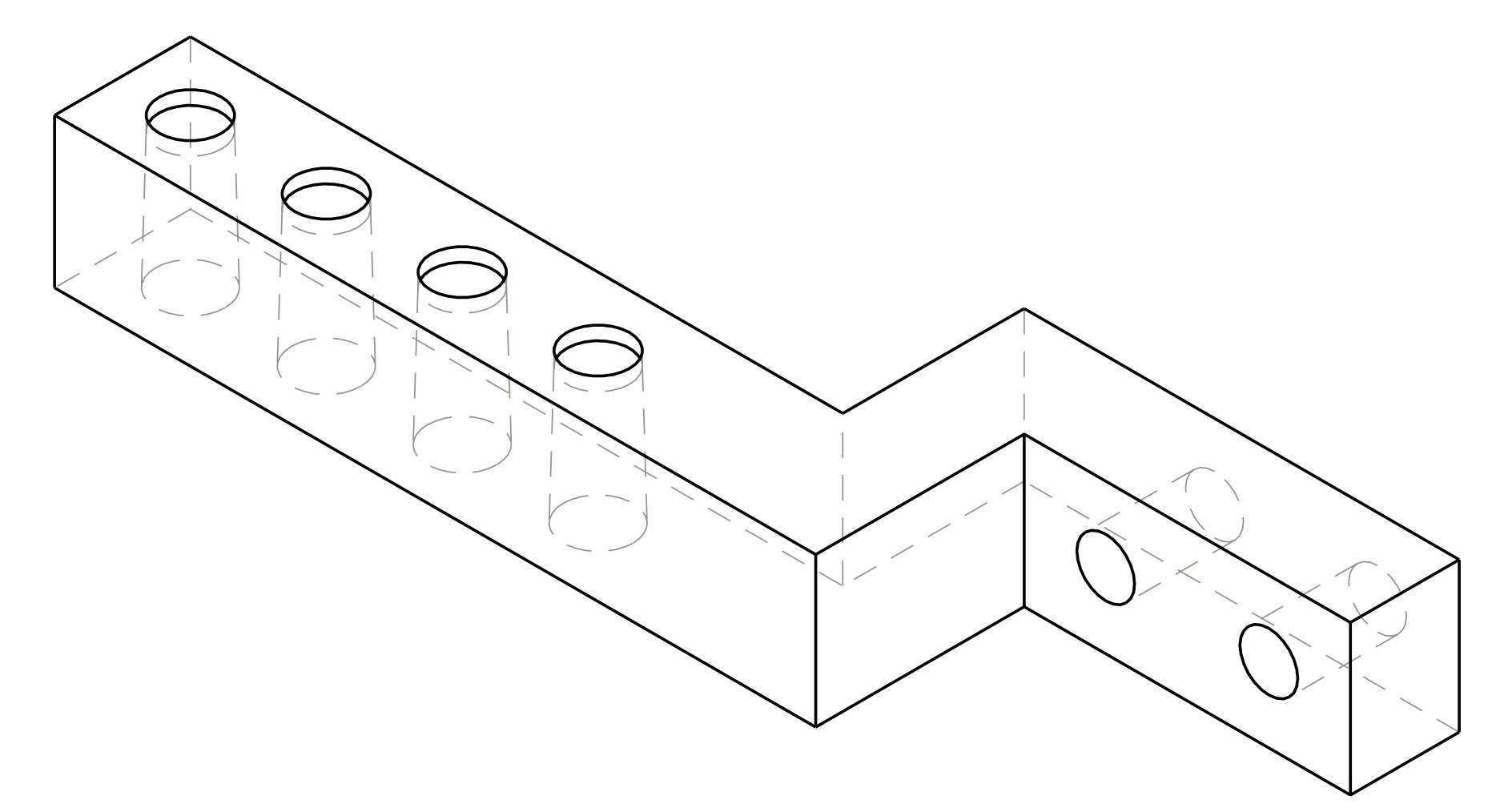

ISOMETRIC VIEW

next assy	AR	-1	TERMINAL LUG OUT	COPPER	7	SEE NOTE	6	1
	CAGE CODE	PART OR IDENTIFYING NO	NOMENCLATURE OR DESCRIPTION	MATERIAL	SPECIFICATION	FIND NO		
SE1406-010								
			NEXT ASSEMBLY					

PARTS LIST

NO REPRESENTATION OR WARRANTY, EXPRESSED OR IMPLIED, IS MADE AS TO THE ACCURACY, COMPLETENESS OR USEFULNESS OF THE INFORMATION OR STATEMENTS CONTAINED IN THESE DRAWINGS, OR THAT THE USE OR DISCLOSURE OF ANY INFORMATION, APPARATUS, METHOD OR PROCESS DISCLOSED IN THESE DRAWINGS MAY NOT INFRINGE PRIVATE RIGHTS OF OTHERS. NO LIABILITY IS ASSUMED WITH RESPECT TO THE USE OF, OR FOR DAMAGES RESULTING FROM THE USE OF, ANY INFORMATION, APPARATUS, METHOD OR PROCESS DISCLOSED IN THESE DRAWINGS. DRAWINGS MADE AVAILABLE FOR INFORMATION TO BIDDER ARE NOT TO BE USED FOR OTHER PURPOSES, AND ARE TO BE RETURNED UPON REQUEST OF THE FORWARDING CONTRACTOR.

**P** THIS DRAWING PRODUCED ON PRO-ENGINEER

REV	DESCRIPTION	BY	DATE	CHK	DEPT	DATE	PE	REQ	DATE	DRNL	DOE	DATE
	REVISION OR ISSUE PURPOSE											

SCALE 1:1 UNO

DES: PJ FOGARTY	8-13-04
DRW: G LOVETT	8-13-04
CHK: G JONES	8-13-04
SECT: :	:
DEPT: :	:
PE: D WILLIAMSON	8-13-04
CR: :	:
PJ: :	:
REO: :	:
PPPL DRFT: :	:
FINISH: .125 UNLESS OTHERWISE SPECIFIED	:

Oak Ridge National Laboratory managed for the DEPARTMENT OF ENERGY under U.S. GOVERNMENT contract DE-AC05-00OR22725 UT-BATTELLE, LLC, Oak Ridge, Tennessee

**UT-BATTELLE**

NATIONAL COMPACT STELLARATOR EXPERIMENT

TERMINAL LUG OUT

VERSION NO.	PLANT	BLDG	FL	SHT OF	TYPE	CLASS
0	X-10	5700	3	1	I	U
RELEASE LEVEL						REV
WIP						0

H  
G  
F  
E  
D  
C  
B  
A

H  
G  
F  
E  
D  
C  
B  
A



- NOTES:
1. INTERPRET DIMENSIONS AND TOLERANCES PER ANSI Y14.5M
  2. DIMENSIONS ARE IN INCHES
  3. DIMENSIONS APPLY AT ROOM TEMPERATURE. OPERATING TEMP 80 K.
  4. GEOMETRY IS DEFINED IN PRO ENGINEER CAD MODELS/FILES SEI406-059.PRT
  5. DRAWING AND MODELS COMBINED DEFINE FINISHED MACHINED PART.
  6. SEE SPECIFICATION, NCSX-CSPEC 141-02-00 FOR ADDITIONAL REQUIREMENTS.
  7. SEE SPECIFICATION NCSX-CSPEC 141-02-00 SECTION 3.2.1.1 FOR MATERIAL REQUIREMENTS.)

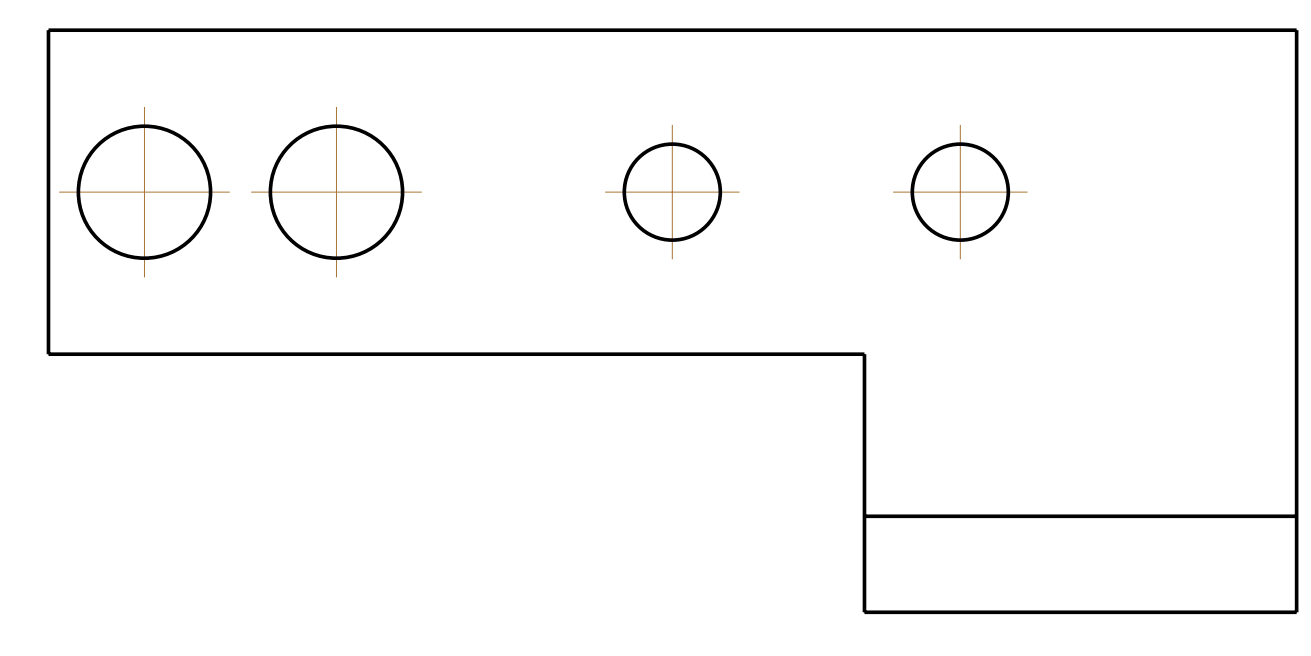
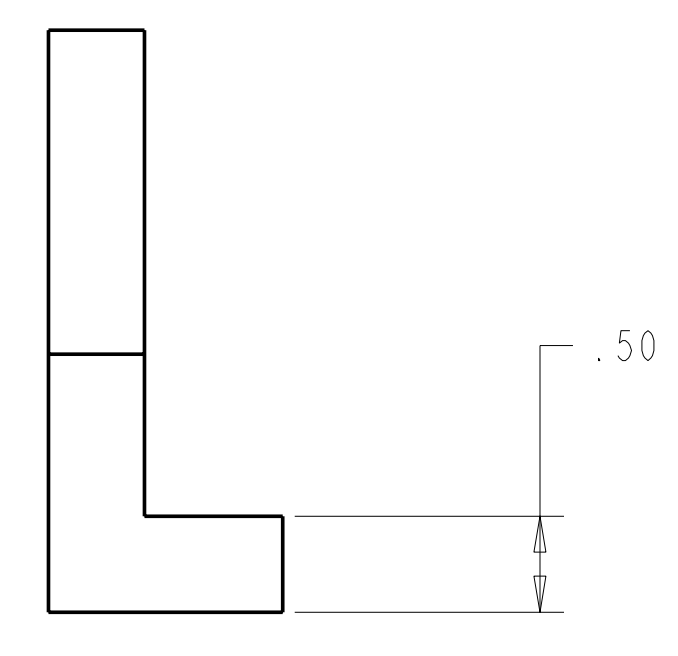
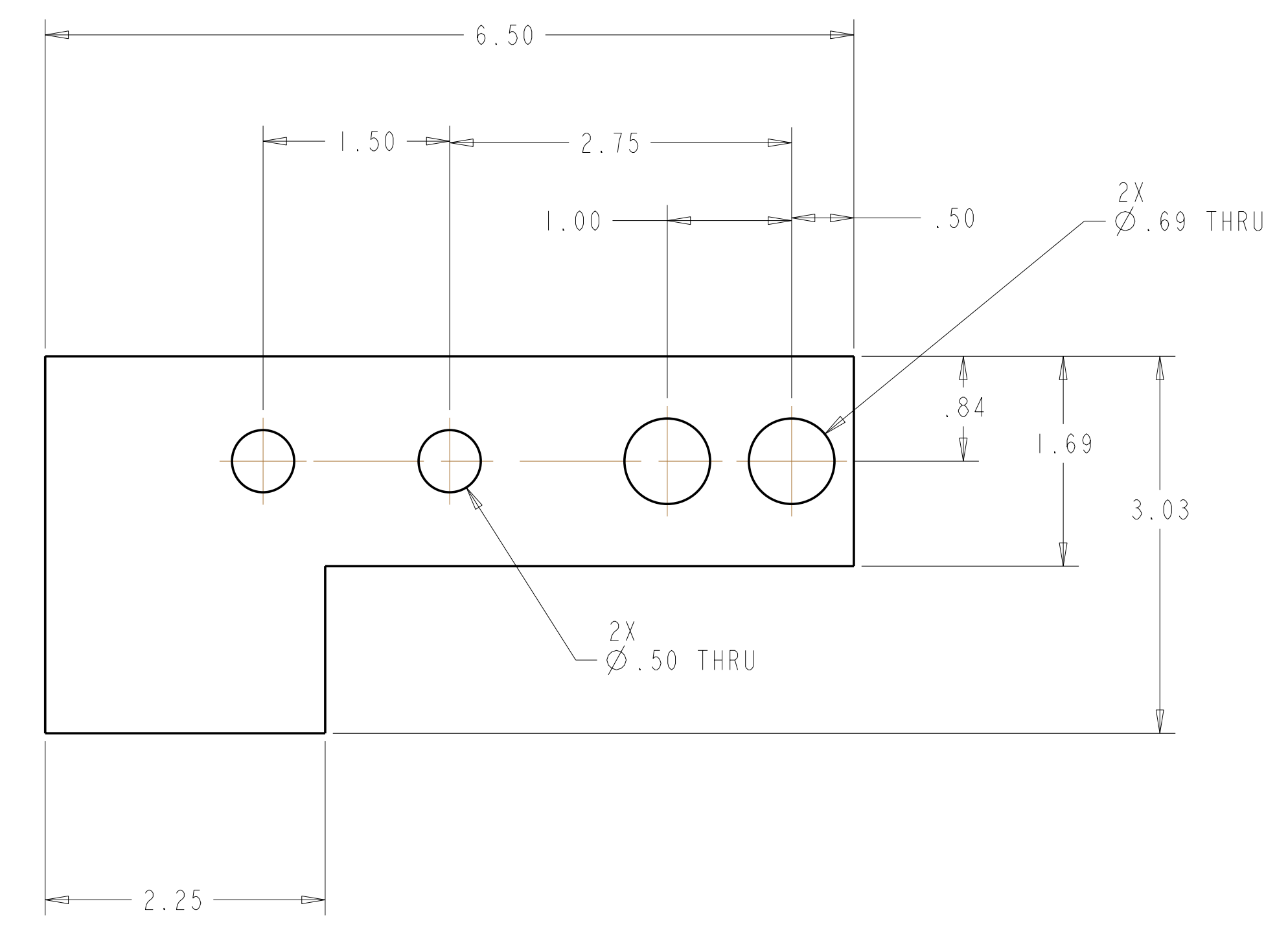
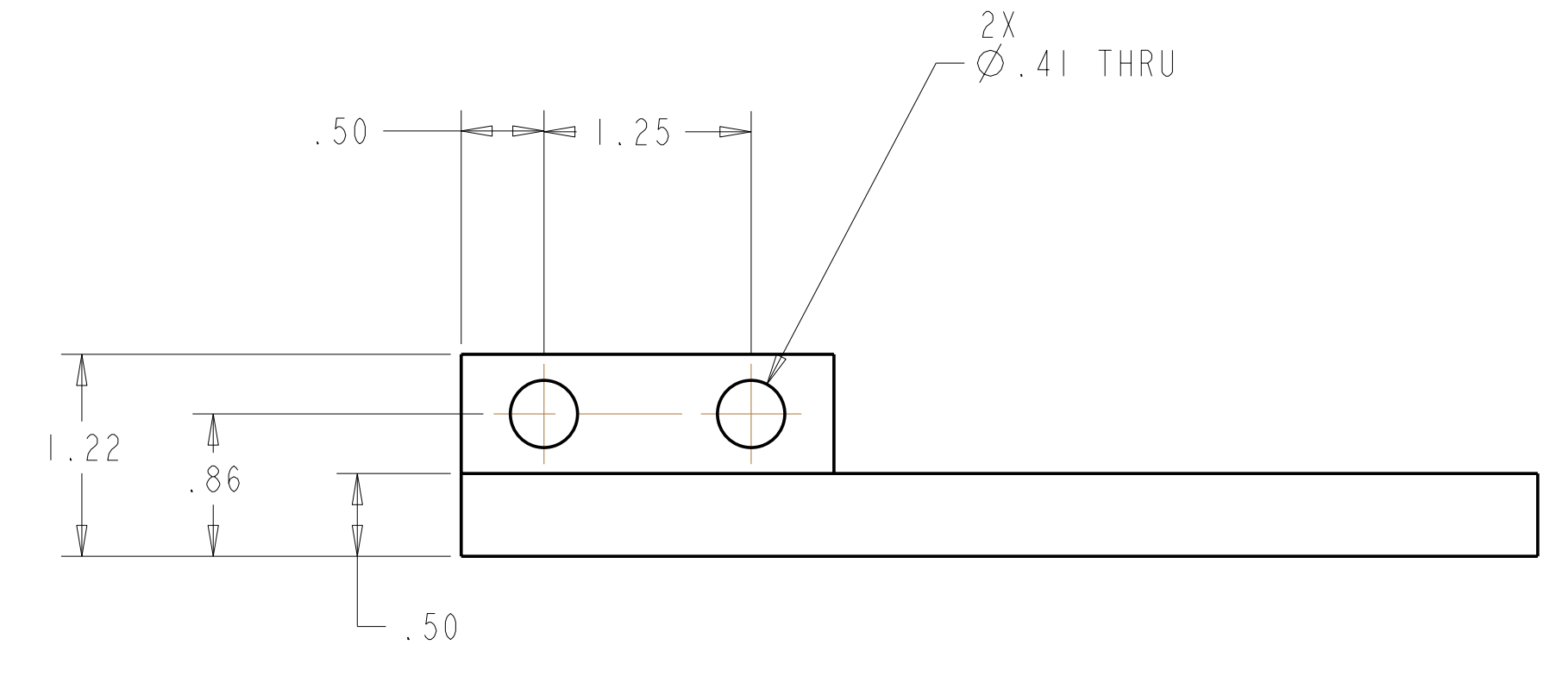

I

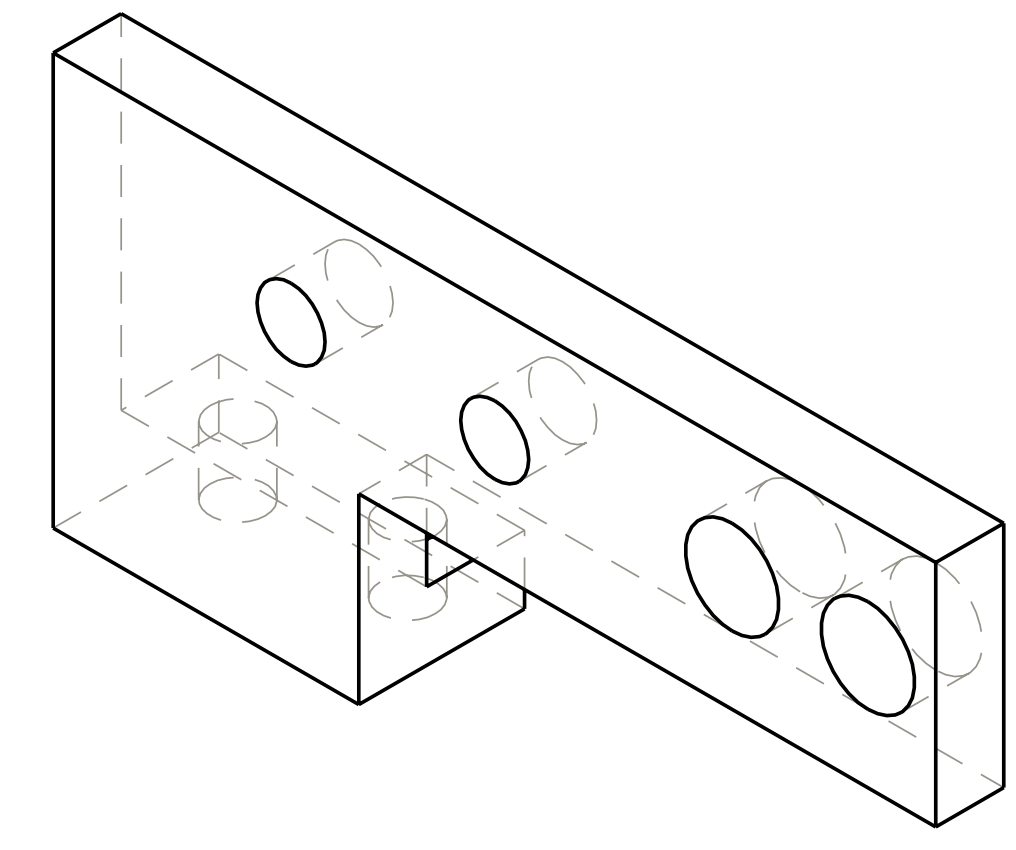

ISOMETRIC VIEW

next assy	AR	-1	JUMPER 5	COPPER 7	SEE NOTE 6	I
SEI406-010	CAGE CODE	PART OR IDENTIFYING NO	NOMENCLATURE OR DESCRIPTION	MATERIAL	SPECIFICATION	FIND NO
		NEXT ASSEMBLY	PARTS LIST			

NO REPRESENTATION OR WARRANTY, EXPRESSED OR IMPLIED, IS MADE AS TO THE ACCURACY, COMPLETENESS OR USEFULNESS OF THE INFORMATION OR STATEMENTS CONTAINED IN THESE DRAWINGS, OR THAT THE USE OR DISCLOSURE OF ANY INFORMATION, APPARATUS, METHOD OR PROCESS DISCLOSED IN THESE DRAWINGS MAY NOT INFRINGE PRIVATE RIGHTS OF OTHERS. NO LIABILITY IS ASSUMED WITH RESPECT TO THE USE OF, OR FOR DAMAGES RESULTING FROM THE USE OF, ANY INFORMATION, APPARATUS, METHOD OR PROCESS DISCLOSED IN THESE DRAWINGS. DRAWINGS MADE AVAILABLE FOR INFORMATION TO BIDDER ARE NOT TO BE USED FOR OTHER PURPOSES, AND ARE TO BE RETURNED UPON REQUEST OF THE FORWARDING CONTRACTOR.

**P** THIS DRAWING PRODUCED ON PRO-ENGINEER

REV	DESCRIPTION	BY	DATE	CHK	DEPT	DATE	PE	REQ	DATE	DRNL	DOE	DATE
REVISION OR ISSUE PURPOSE						REVISION APPROVAL						

SCALE 1:1 UNO	DES PJ FOGARTY 8-13-04
TOLERANCES UNLESS OTHERWISE SPECIFIED	DRW G LOVETT 8-13-04
FRACTIONS ±.01	CHK G JONES 8-13-04
XX DECIMALS ±.005	SECT :
XXX DECIMALS ±.0015	DEPT :
ANGLES ±0°15'	PE D WILLIAMSON 8-13-04
FINISH .125 UNLESS OTHERWISE SPECIFIED	CR :
	PJ :
	REO :
	PPPL DRFT :
	:
	:
	VERSION NO. :
	PLANT X-10
	BLDG 5700
	FL 3
	SHT OF 1
	TYPE I
	CLASS S
	REV U
	WIP
	SEI406-059
	REV 0

Oak Ridge National Laboratory  
 managed for the DEPARTMENT OF ENERGY under  
 U.S. GOVERNMENT contract DE-AC05-00OR22725  
 UT-BATTELLE, LLC. Oak Ridge, Tennessee

**UT-BATTELLE**

NATIONAL COMPACT STELLARATOR EXPERIMENT

JUMPER 5

VERSION NO. I  
 PLANT X-10  
 BLDG 5700  
 FL 3  
 SHT OF 1  
 TYPE I  
 CLASS S  
 REV U

RELEASE LEVEL WIP  
 SEI406-059  
 REV 0

SEI406-059

A

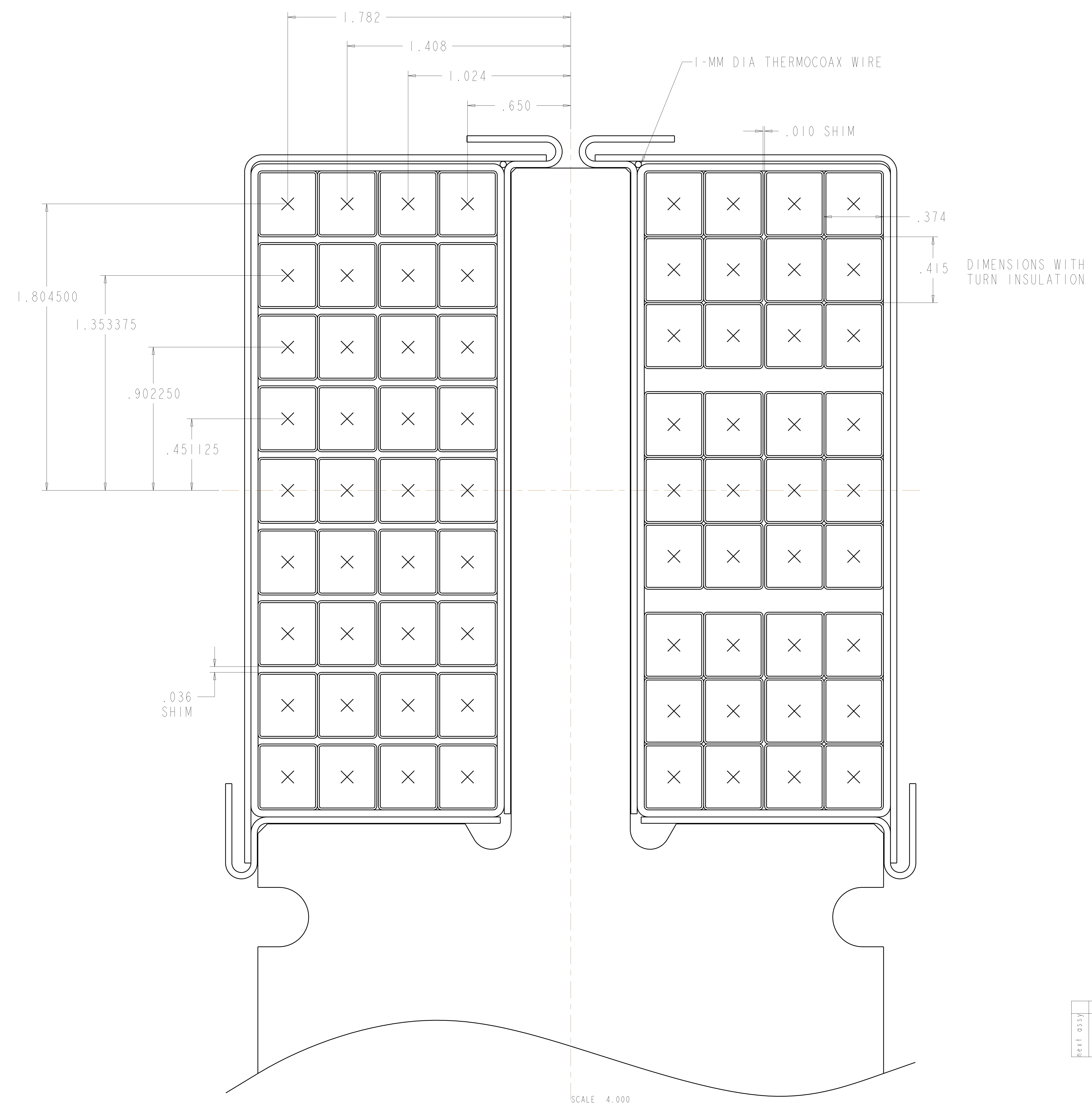

CAGE CODE	PART OR IDENTIFYING NO	NOMENCLATURE OR DESCRIPTION	MATERIAL	SPECIFICATION	FIND NO
NEXT ASSEMBLY PARTS LIST					

NO REPRESENTATION OR WARRANTY, EXPRESSED OR IMPLIED, IS MADE AS TO THE ACCURACY, COMPLETENESS OR USEFULNESS OF THE INFORMATION OR STATEMENTS CONTAINED IN THESE DRAWINGS, OR THAT THE USE OR DISCLOSURE OF ANY INFORMATION, APPARATUS, METHOD OR PROCESS DISCLOSED IN THESE DRAWINGS MAY NOT INFRINGE PRIVATE RIGHTS OF OTHERS. NO LIABILITY IS ASSUMED WITH RESPECT TO THE USE OF, OR FOR DAMAGES RESULTING FROM THE USE OF, ANY INFORMATION, APPARATUS, METHOD OR PROCESS DISCLOSED IN THESE DRAWINGS. DRAWINGS MADE AVAILABLE FOR INFORMATION TO BIDDER ARE NOT TO BE USED FOR OTHER PURPOSES, AND ARE TO BE RETURNED UPON REQUEST OF THE FORWARDING CONTRACTOR.

**P** THIS DRAWING PRODUCED ON PRO-ENGINEER

REV	DESCRIPTION	BY	DATE	CHK	DEPT	DATE	PE	REQ	DATE	ORNL	DOE	DATE
REVISION OR ISSUE PURPOSE						REVISION APPROVAL						

SCALE		DES
TOLERANCES UNLESS OTHERWISE SPECIFIED	DRW DEW	0/13/04
FRACTIONS	CHK	
XX DECIMALS ±.01	SECT	
XXX DECIMALS ±.005	DEPT	
ANGLES ±0°15'	PE	
FINISH .125 UNLESS OTHERWISE SPECIFIED	CR	
	PJ	
	RED	
	PPPL DRFT	

Oak Ridge National Laboratory  
managed for the DEPARTMENT OF ENERGY under  
U.S. GOVERNMENT contract DE-AC05-00OR22725  
UT-BATTELLE, LLC, Oak Ridge, Tennessee

**UT-BATTELLE**

**NATIONAL COMPACT STELLARATOR EXPERIMENT**

**TRC WINDING PACK XSEC**

VERSION NO.	PLANT	BLDG	FL	SHT OF	TYPE	CLASS
	X-10	5700	3	1	A	U
RELEASE LEVEL						
SE 1406-090						

H  
G  
F  
E  
D  
C  
B  
A

SE 1406-090

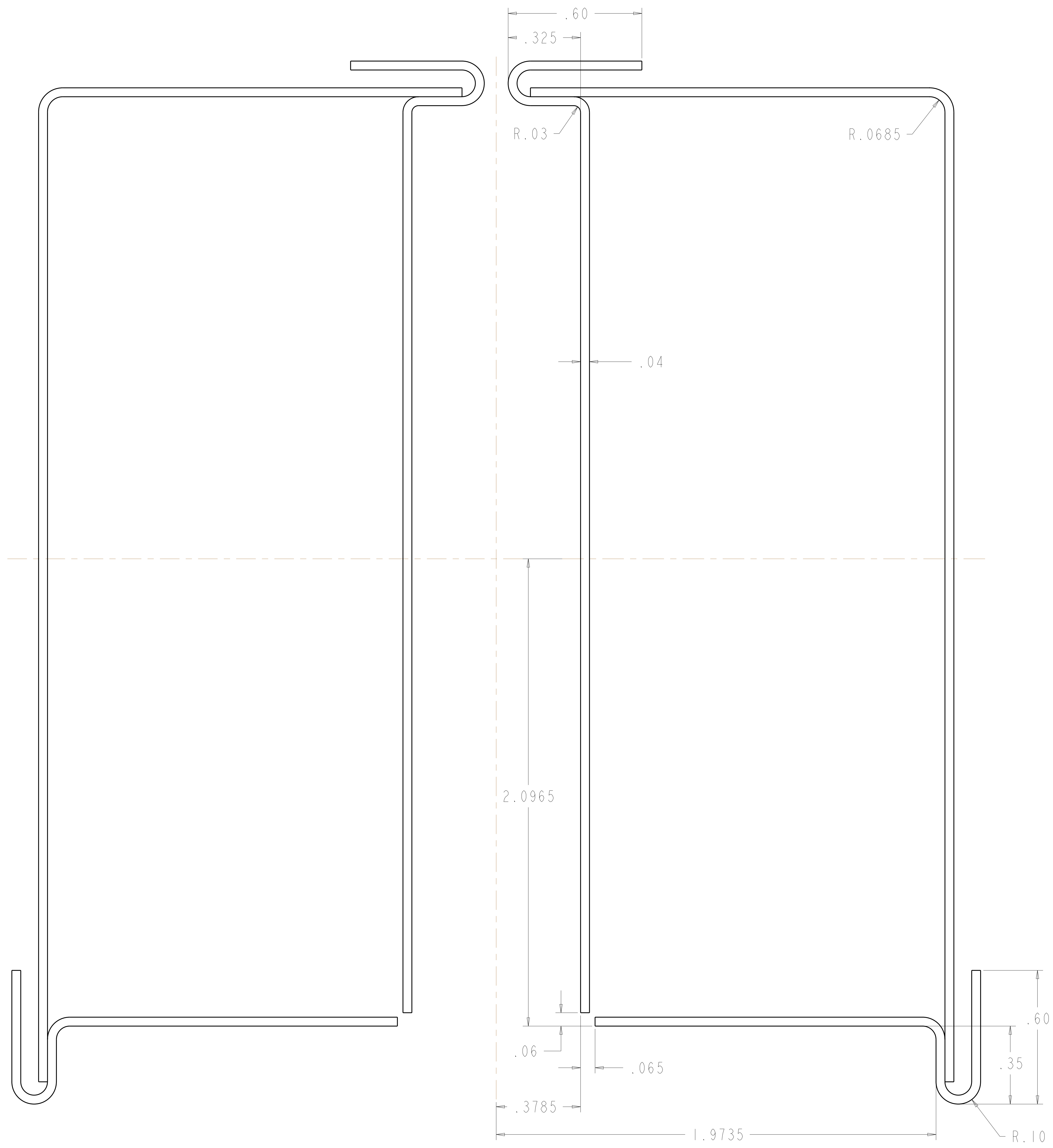

CLADDING / CHILL PLATE  
SCALE 5.00

CAGE CODE	PART OR IDENTIFYING NO	NOMENCLATURE OR DESCRIPTION	MATERIAL	SPECIFICATION	FIND NO
←	NEXT ASSEMBLY	PARTS LIST			

NO REPRESENTATION OR WARRANTY, EXPRESSED OR IMPLIED, IS MADE AS TO THE ACCURACY, COMPLETENESS OR USEFULNESS OF THE INFORMATION OR STATEMENTS CONTAINED IN THESE DRAWINGS, OR THAT THE USE OR DISCLOSURE OF ANY INFORMATION, APPARATUS, METHOD OR PROCESS DISCLOSED IN THESE DRAWINGS MAY NOT INFRINGE PRIVATE RIGHTS OF OTHERS. NO LIABILITY IS ASSUMED WITH RESPECT TO THE USE OF, OR FOR DAMAGES RESULTING FROM THE USE OF, ANY INFORMATION, APPARATUS, METHOD OR PROCESS DISCLOSED IN THESE DRAWINGS. DRAWINGS MADE AVAILABLE FOR INFORMATION TO BIDDER ARE NOT TO BE USED FOR OTHER PURPOSES, AND ARE TO BE RETURNED UPON REQUEST OF THE FORWARDING CONTRACTOR.

**P** THIS DRAWING PRODUCED ON PRO-ENGINEER

REV	DESCRIPTION	BY	DATE	CHK	DEPT	DATE	PE	REQ	DATE	ORNL	DOE	DATE

SCALE NOTED	DES: WILLIAMSON	8/12/04
TOLERANCES UNLESS OTHERWISE SPECIFIED	CHK :	:
FRACTIONS	SECT :	:
XX DECIMALS ± .01	DEPT :	:
XXX DECIMALS ± .005	PE :	:
ANGLES ± 0'15"	CR :	:
BREAK SHARP EDGES .06 MAX	PJ :	:
FINISH .125 UNLESS OTHERWISE SPECIFIED	RED :	:
PPPL DRFT		
DRAWING APPROVALS		

<b>UT-BATTELLE</b>		Oak Ridge National Laboratory managed for the DEPARTMENT OF ENERGY under U.S. GOVERNMENT contract DE-AC05-00OR22725 UT-BATTELLE, LLC, Oak Ridge, Tennessee	
NATIONAL COMPACT STELLARATOR EXPERIMENT			
TWISTED RACETRACK COIL CLADDING / CHILL PLATE LAYOUT			
VERSION NO.	PLANT	BLDG	FL
	X-10	5700	3
			1
			1
			A
			U
RELEASE LEVEL	SE1406-091		

H  
G  
F  
E  
D  
C  
B  
A

SE1406-091

- NOTES:
1. INTERPRET DIMENSIONS AND TOLERANCES PER ANSI Y14.5M
  2. DIMENSIONS ARE IN INCHES
  3. DIMENSIONS APPLY AT ROOM TEMPERATURE. OPERATING TEMP 80 K.
  4. GEOMETRY IS DEFINED IN PRO ENGINEER CAD MODELS/FILES SE1406-118.PRT
  5. DRAWING AND MODELS COMBINED DEFINE FINISHED MACHINED PART.
  6. SEE SPECIFICATION, NCSX-CSPEC 141-02-00 FOR ADDITIONAL REQUIREMENTS.
  7. SEE SPECIFICATION NCSX-CSPEC 141-02-00 SECTION 3.2.1.1 FOR MATERIAL REQUIREMENTS.

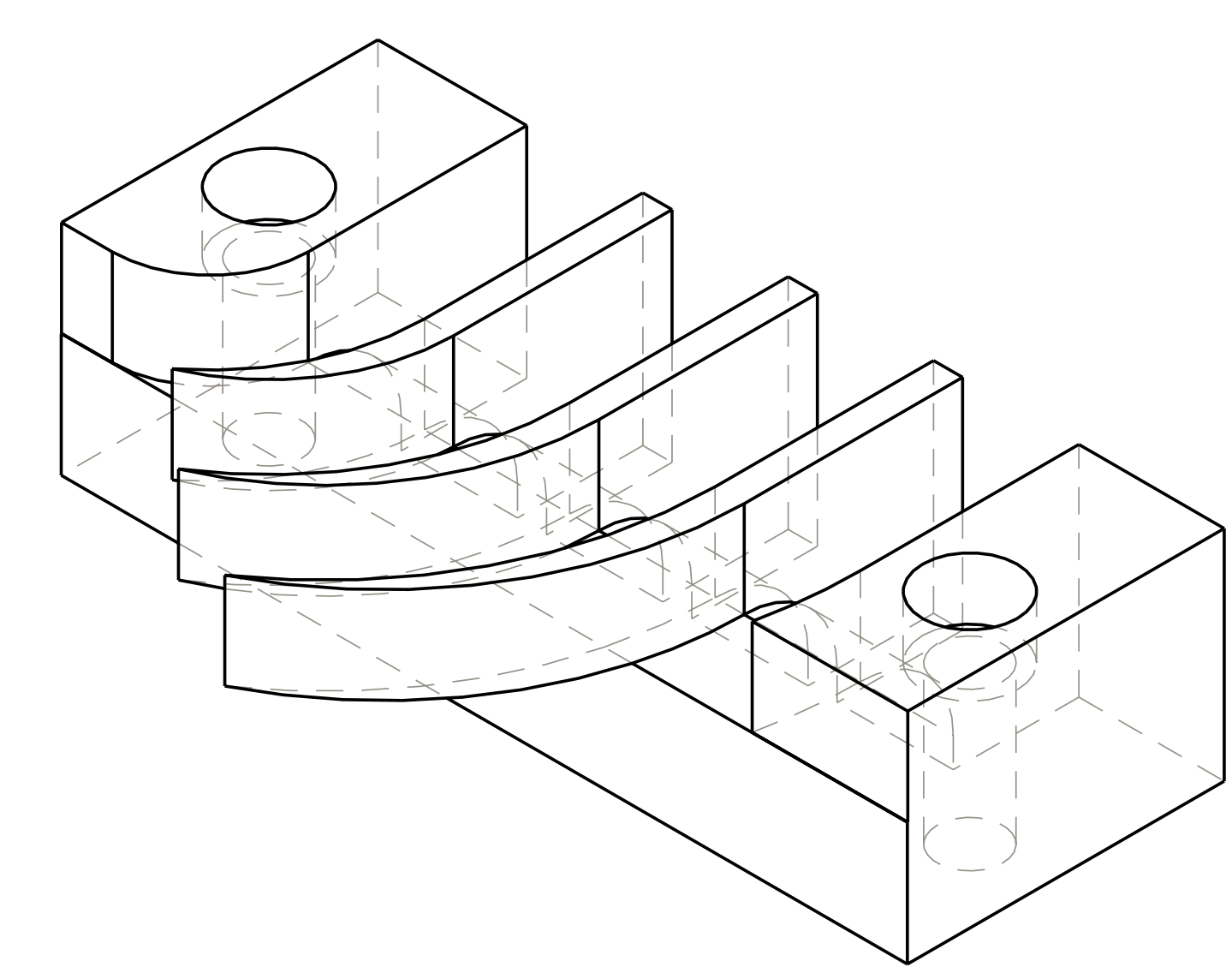

ISOMETRIC VIEW

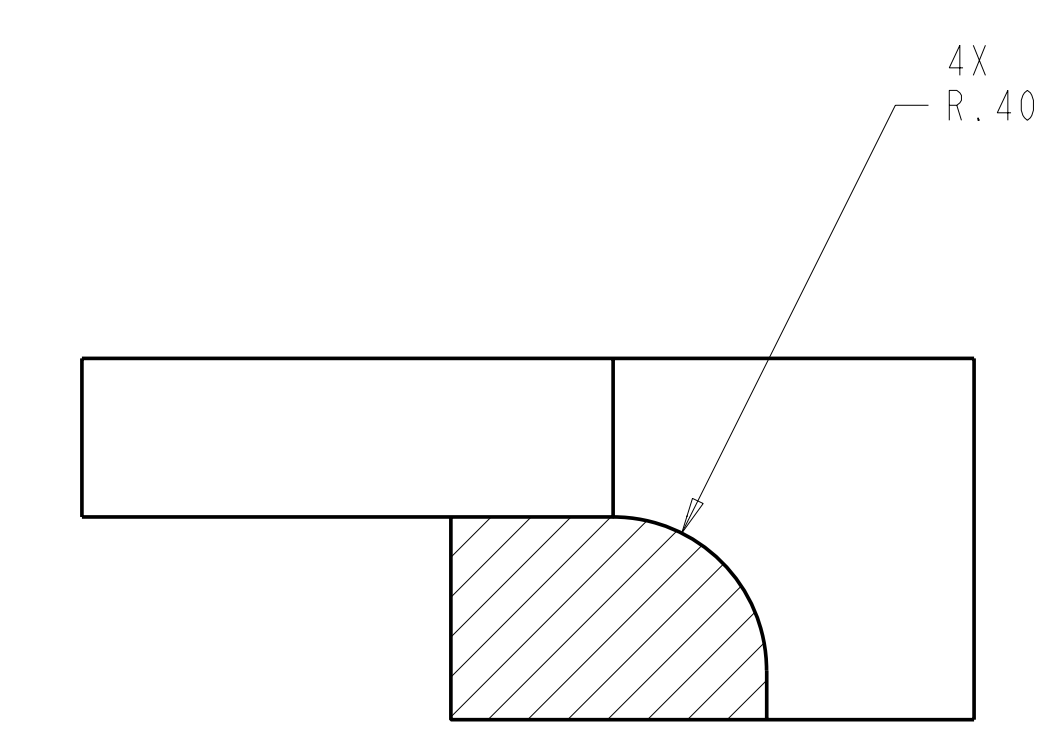
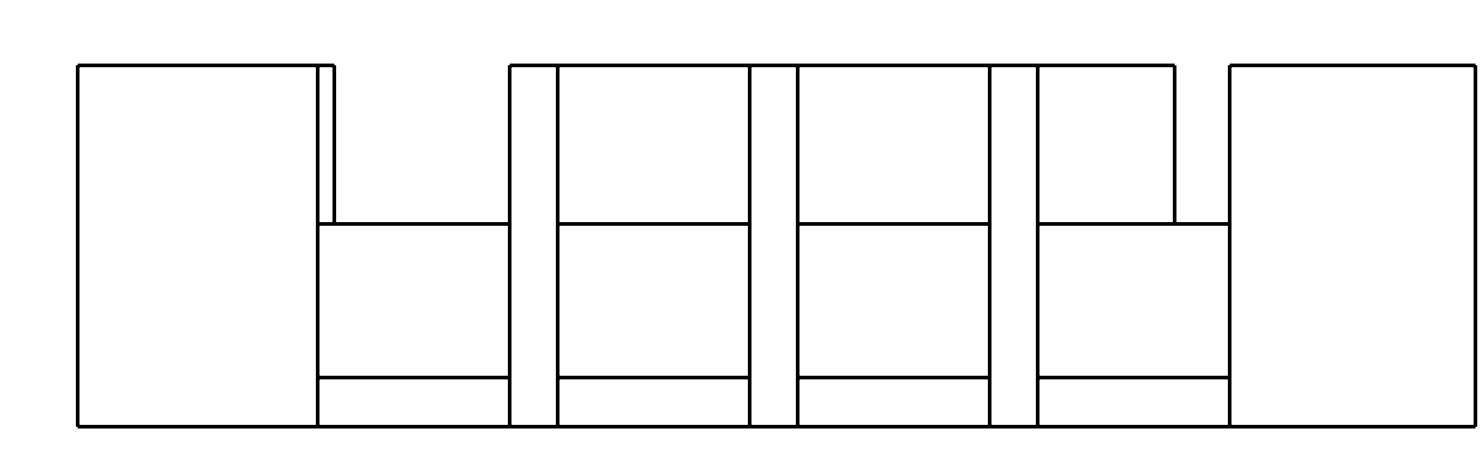
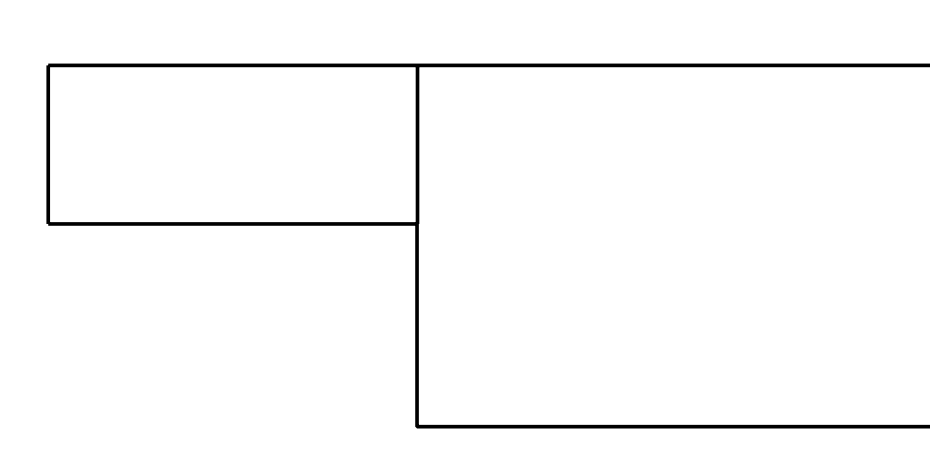
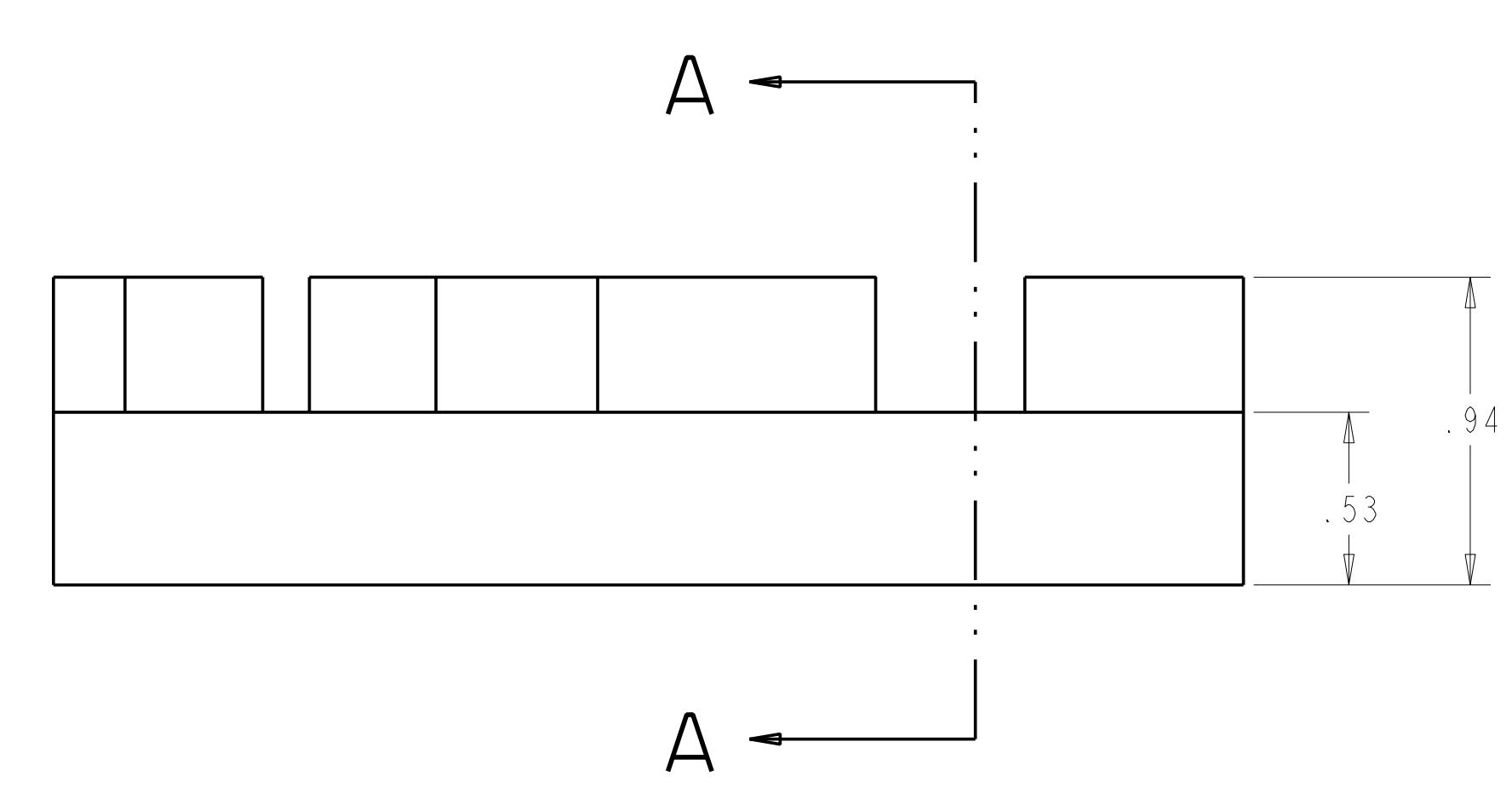
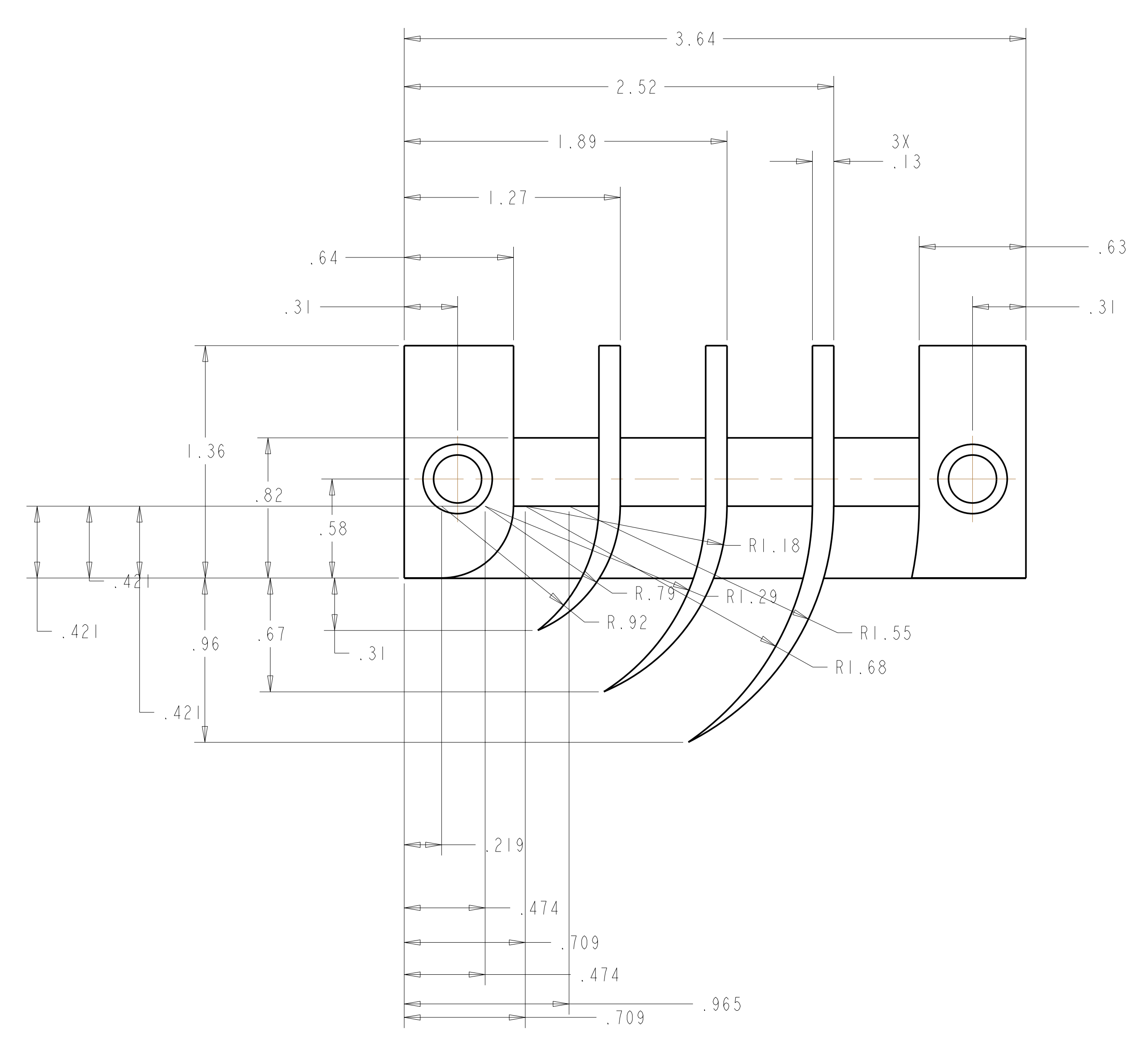

SECTION A-A

I

CAGE CODE	PART OR IDENTIFYING NO	UPPER WINDING NOMENCLATURE OR DESCRIPTION	SLA MATERIAL	SPECIFICATION	FIND NO
SE1406-010	-1	UPPER WINDING	SLA		
NEXT ASSEMBLY					

PARTS LIST

FOR INFORMATION ONLY  
 NOT APPROVED FOR FABRICATION

<p>NO REPRESENTATION OR WARRANTY, EXPRESSED OR IMPLIED, IS MADE AS TO THE ACCURACY, COMPLETENESS OR USEFULNESS OF THE INFORMATION OR STATEMENTS CONTAINED IN THESE DRAWINGS, OR THAT THE USE OR DISCLOSURE OF ANY INFORMATION, APPARATUS, METHOD OR PROCESS DISCLOSED IN THESE DRAWINGS MAY NOT INFRINGE PRIVATE RIGHTS OF OTHERS. NO LIABILITY IS ASSUMED WITH RESPECT TO THE USE OF, OR FOR DAMAGES RESULTING FROM THE USE OF, ANY INFORMATION, APPARATUS, METHOD OR PROCESS DISCLOSED IN THESE DRAWINGS. DRAWINGS MADE AVAILABLE FOR INFORMATION TO BIDDER ARE NOT TO BE USED FOR OTHER PURPOSES, AND ARE TO BE RETURNED UPON REQUEST OF THE FORWARDING CONTRACTOR.</p>										<p><b>P</b> THIS DRAWING PRODUCED ON PRO-ENGINEER</p>										<p>SCALE 2:1                  TOLERANCES UNLESS OTHERWISE SPECIFIED:                  FRACTIONS ±.01                  XX DECIMALS ±.005                  XXX DECIMALS ±.0015                  ANGLES ±0°15'                  BREAK SHARP EDGES .06 MAX                  FINISH .125 UNLESS OTHERWISE SPECIFIED</p>										<p>DES: PJ FOGARTY 8-03-04                  DRW: G LOVETT 8-03-04                  CHK: G JONES 8-03-04                  SECT: :                  DEPT: :                  PE: D WILLIAMSON 8-03-04                  CR: :                  PJ: :                  REO: :                  PPPL DRFT: :                  : :                  : :                  : :                  DRAWING APPROVALS DATE</p>										<p>Oak Ridge National Laboratory managed for the DEPARTMENT OF ENERGY under U.S. GOVERNMENT contract DE-AC05-00OR22725 UT-BATTELLE, LLC, Oak Ridge, Tennessee  <b>UT-BATTELLE</b>                  NATIONAL COMPACT STELLARATOR EXPERIMENT                  BLOCK- UPPER WINDING</p>										<p>VERSION NO. 2                  PLANT X-10                  BLDG 5700                  FL 3                  SHT OF 1                  TYPE I                  CLASS S                  U                  RELEASE LEVEL WIP                  SE1406-118                  REV 0</p>									
REV	DESCRIPTION	BY	DATE	CHK	DEPT	DATE	PE	REQ	DATE	DRNL	DOE	DATE																																															
REVISION OR ISSUE PURPOSE													REVISION APPROVAL																																														

H  
G  
F  
E  
D  
C  
B  
A



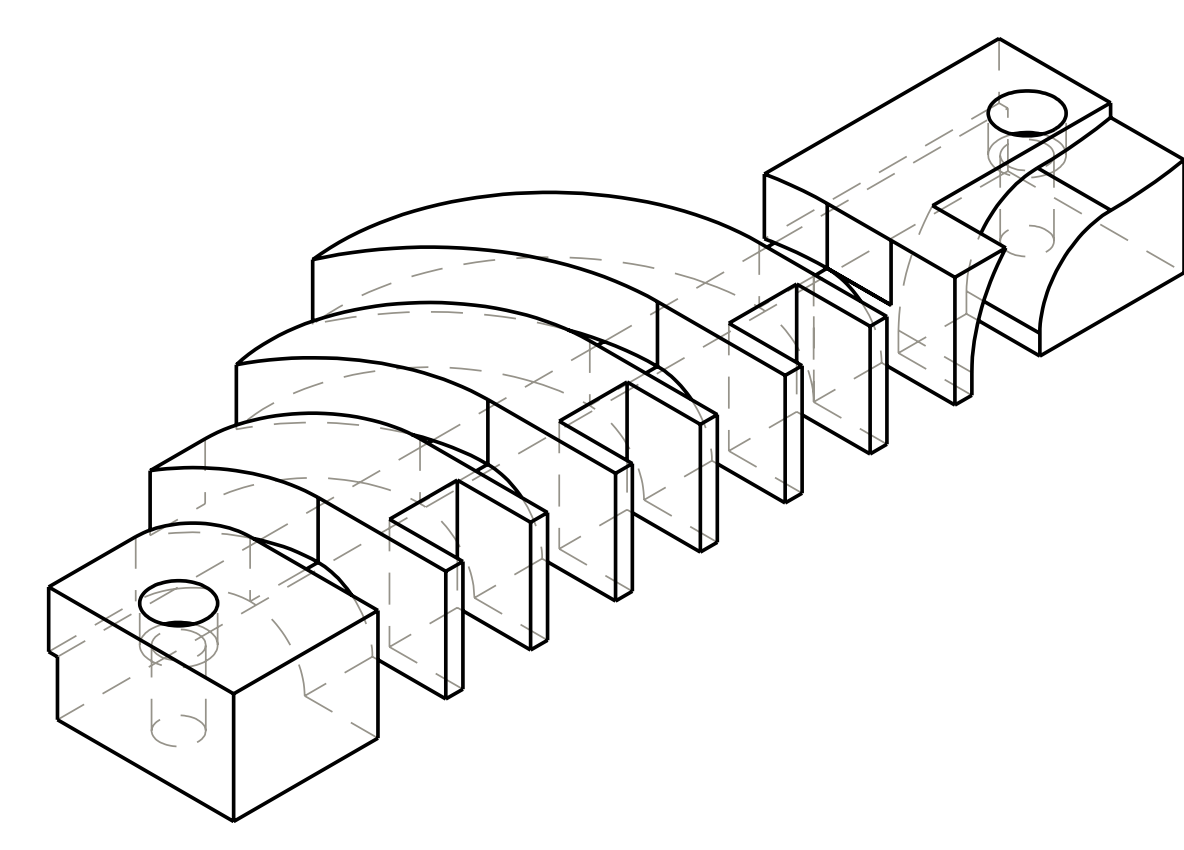
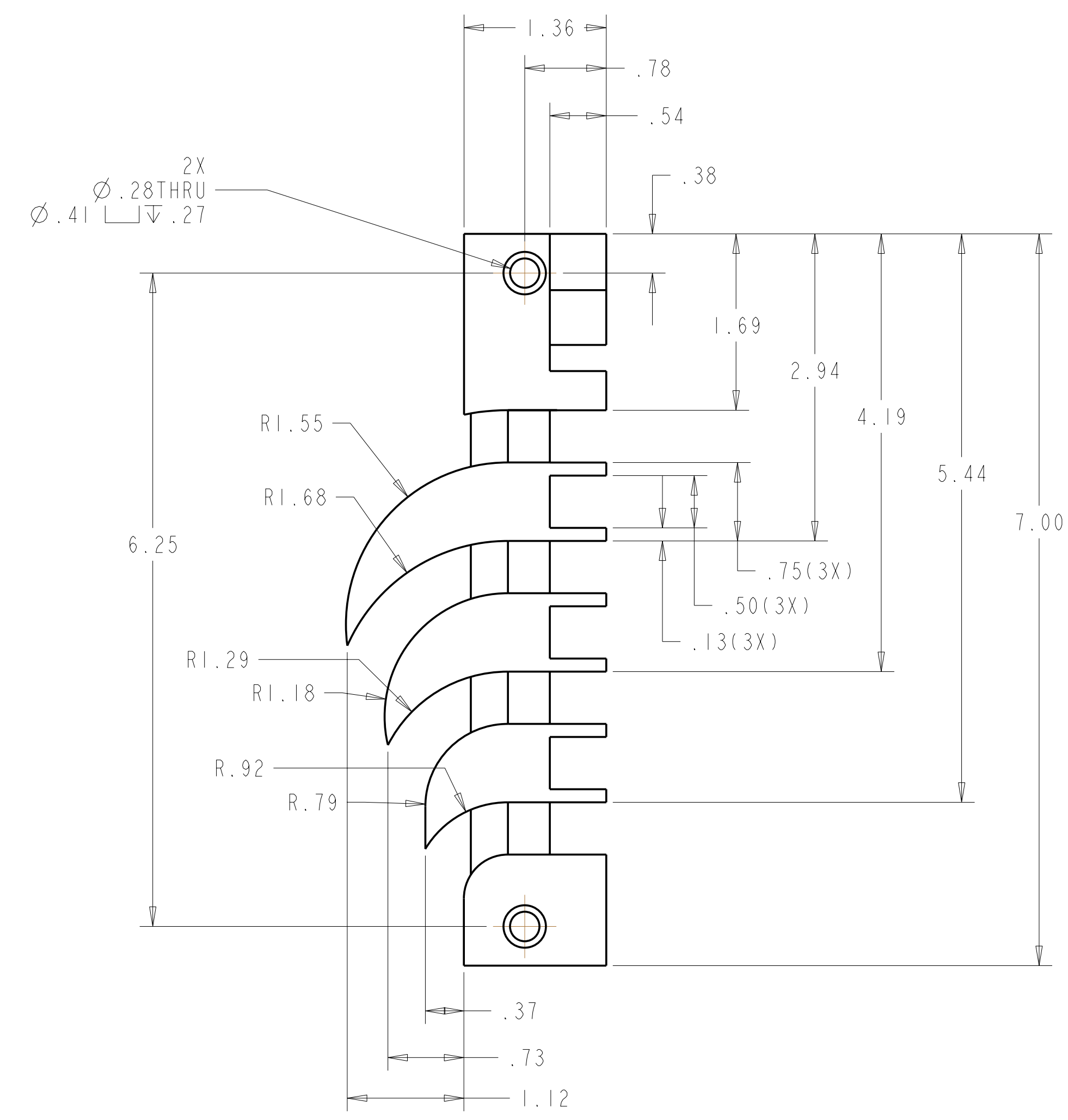

- NOTES:
1. INTERPRET DIMENSIONS AND TOLERANCES PER ANSI Y14.5M
  2. DIMENSIONS ARE IN INCHES
  3. DIMENSIONS APPLY AT ROOM TEMPERATURE. OPERATING TEMP 80 K.
  4. GEOMETRY IS DEFINED IN PRO ENGINEER CAD MODELS/FILES SE1406-122.PRT
  5. DRAWING AND MODELS COMBINED DEFINE FINISHED MACHINED PART.
  6. SEE SPECIFICATION, NCSX-CSPEC 141-02-00 FOR ADDITIONAL REQUIREMENTS.
  7. SEE SPECIFICATION NCSX-CSPEC 141-02-00 SECTION 3.2.1.1 FOR MATERIAL REQUIREMENTS.

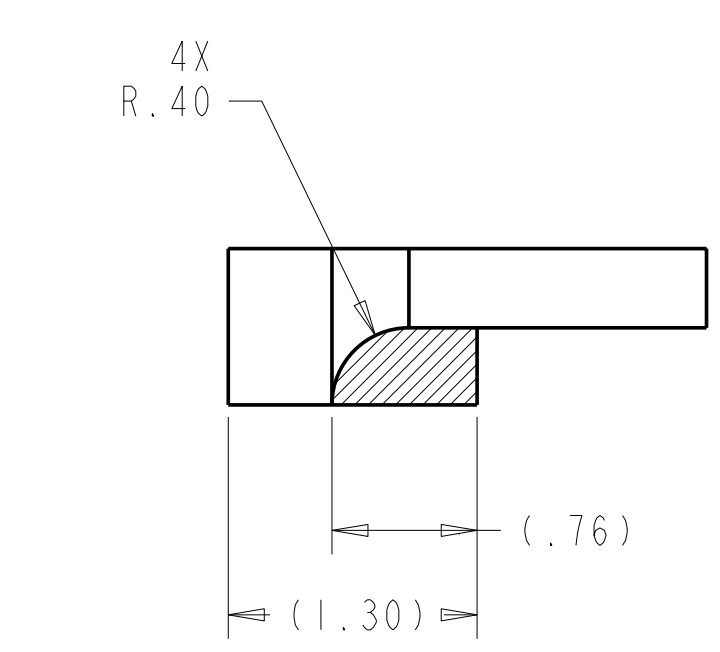
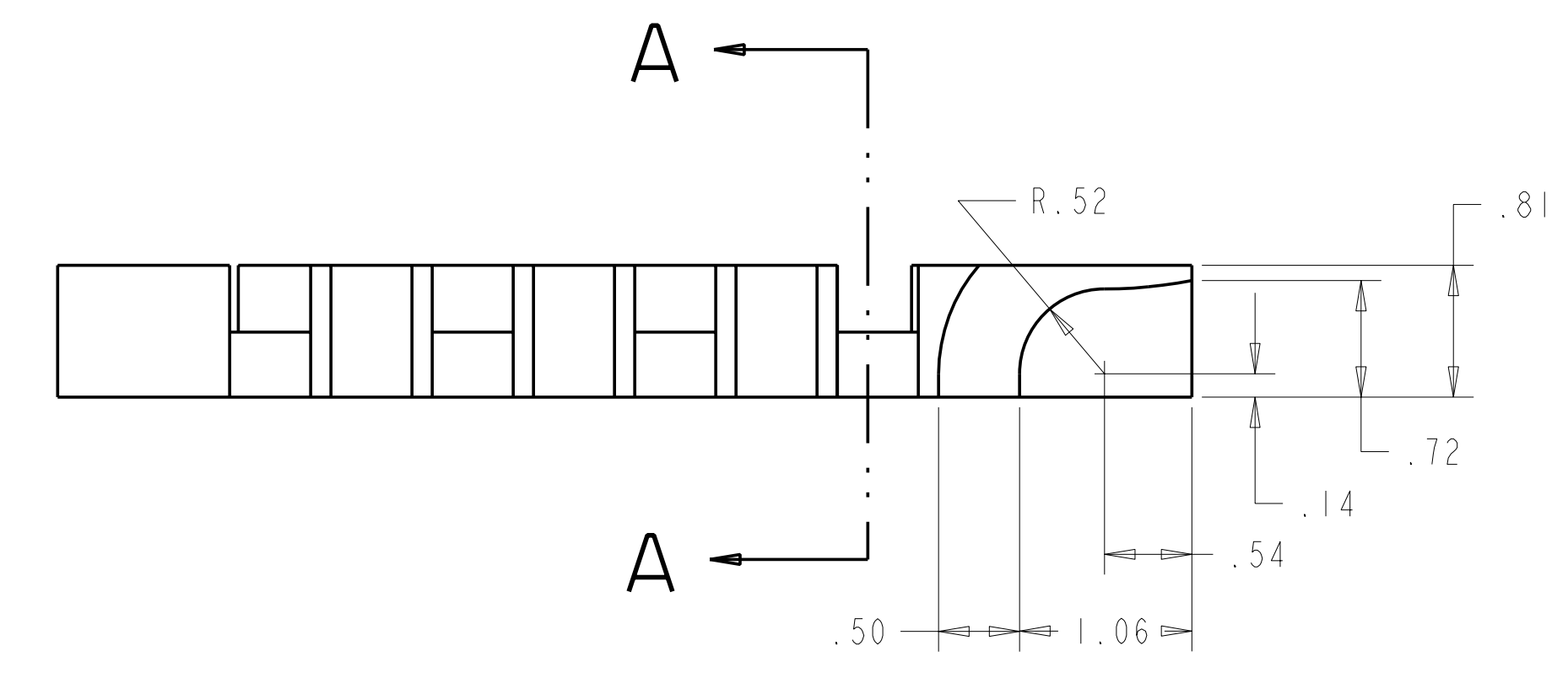
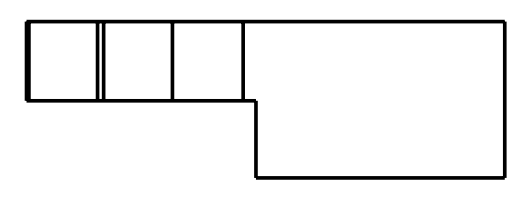
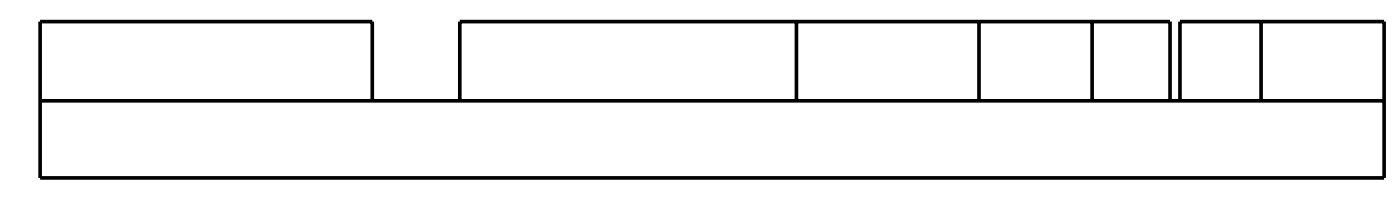

SECTION A-A

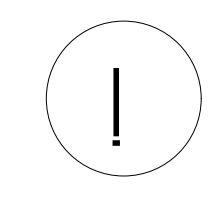

CAGE CODE	PART OR IDENTIFYING NO	NOMENCLATURE OR DESCRIPTION	SLA MATERIAL	SPECIFICATION	FIND NO
SE1406-010					

← NEXT ASSEMBLY

PARTS LIST

FOR INFORMATION ONLY  
NOT APPROVED FOR FABRICATION

NO REPRESENTATION OR WARRANTY, EXPRESSED OR IMPLIED, IS MADE AS TO THE ACCURACY, COMPLETENESS OR USEFULNESS OF THE INFORMATION OR STATEMENTS CONTAINED IN THESE DRAWINGS, OR THAT THE USE OR DISCLOSURE OF ANY INFORMATION, APPARATUS, METHOD OR PROCESS DISCLOSED IN THESE DRAWINGS MAY NOT INFRINGE PRIVATE RIGHTS OF OTHERS. NO LIABILITY IS ASSUMED WITH RESPECT TO THE USE OF, OR FOR DAMAGES RESULTING FROM THE USE OF, ANY INFORMATION, APPARATUS, METHOD OR PROCESS DISCLOSED IN THESE DRAWINGS. DRAWINGS MADE AVAILABLE FOR INFORMATION TO BIDDER ARE NOT TO BE USED FOR OTHER PURPOSES, AND ARE TO BE RETURNED UPON REQUEST OF THE FORWARDING CONTRACTOR.

**P** THIS DRAWING PRODUCED ON PRO-ENGINEER

REV	DESCRIPTION	BY	DATE	CHK	DEPT	DATE	PE	REQ	DATE	DRNL	DOE	DATE

SCALE 2:1	DES PJ FOGARTY 8-03-04
TOLERANCES UNLESS OTHERWISE SPECIFIED	DRW G LOVETT 8-03-04
FRACTIONS	CHK G JONES 8-03-04
XX DECIMALS ±.01	DEPT :
XXX DECIMALS ±.005	PE D WILLIAMSON 8-03-04
ANGLES ±0°15'	CR :
BREAK SHARP EDGES 06 MAX	PJ :
FINISH .125 UNLESS OTHERWISE SPECIFIED	REQ :
	REP :
	PPPL DRFT :

<b>UT-BATTELLE</b> <small>U.S. GOVERNMENT CONTRACT DE-AC05-00OR22725 UT-BATTELLE, LLC. Oak Ridge, Tennessee</small>	
<b>NATIONAL COMPACT STELLARATOR EXPERIMENT</b>	
<b>BLOCK WINDING LOWER</b>	
VERSION NO. 2+	PLANT X-10
BLDG 5700	FL 3
SHT OF 1	TYPE S
CLASS U	REV 0
RELEASE LEVEL WIP	SE1406-122



- NOTES:
1. INTERPRET DIMENSIONS AND TOLERANCES PER ANSI Y14.5M
  2. DIMENSIONS ARE IN INCHES
  3. DIMENSIONS APPLY AT ROOM TEMPERATURE. OPERATING TEMP 80 K.
  4. GEOMETRY IS DEFINED IN PRO ENGINEER CAD MODELS/FILES SE1406-123.PRT
  5. DRAWING AND MODELS COMBINED DEFINE FINISHED MACHINED PART.
  6. SEE SPECIFICATION, NCSX-CSPEC 141-02-00 FOR ADDITIONAL REQUIREMENTS.
  7. SEE SPECIFICATION NCSX-CSPEC 141-02-00 SECTION 3.2.1.1 FOR MATERIAL REQUIREMENTS.1

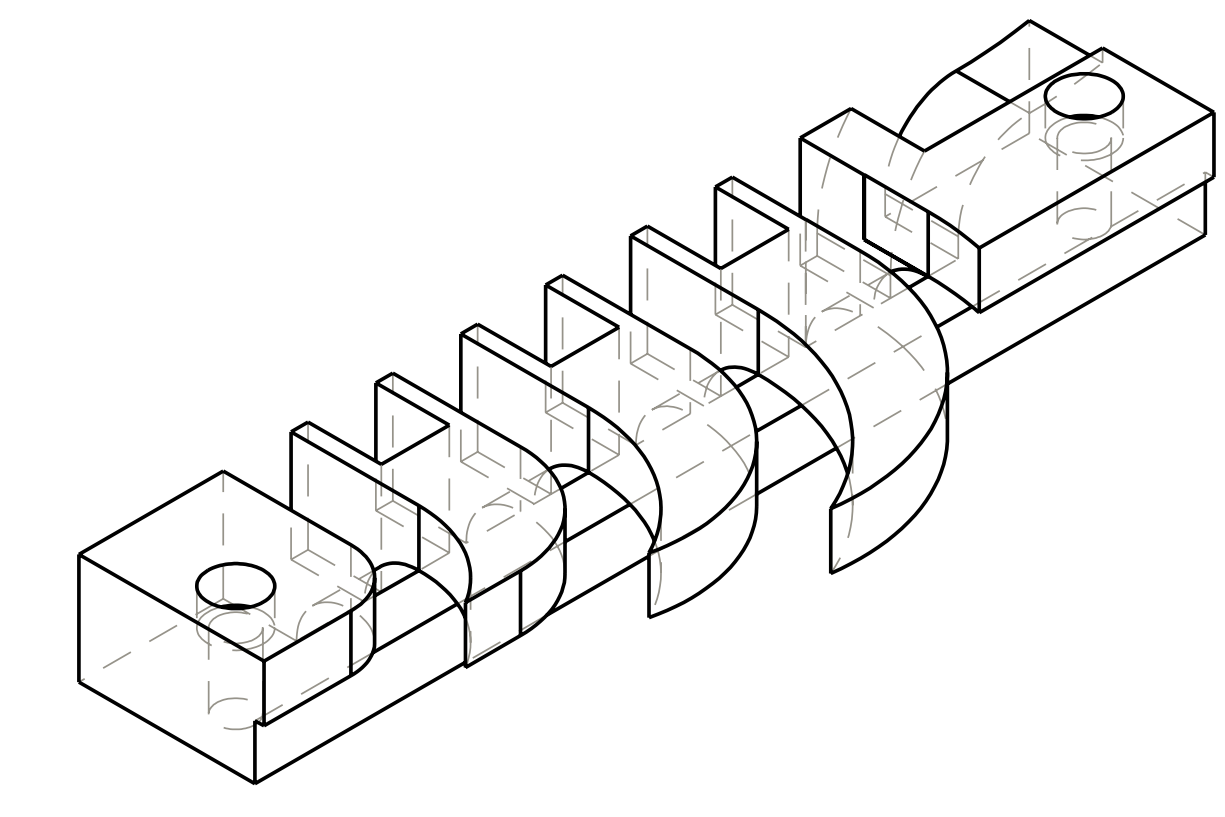

ISOMETRIC VIEW

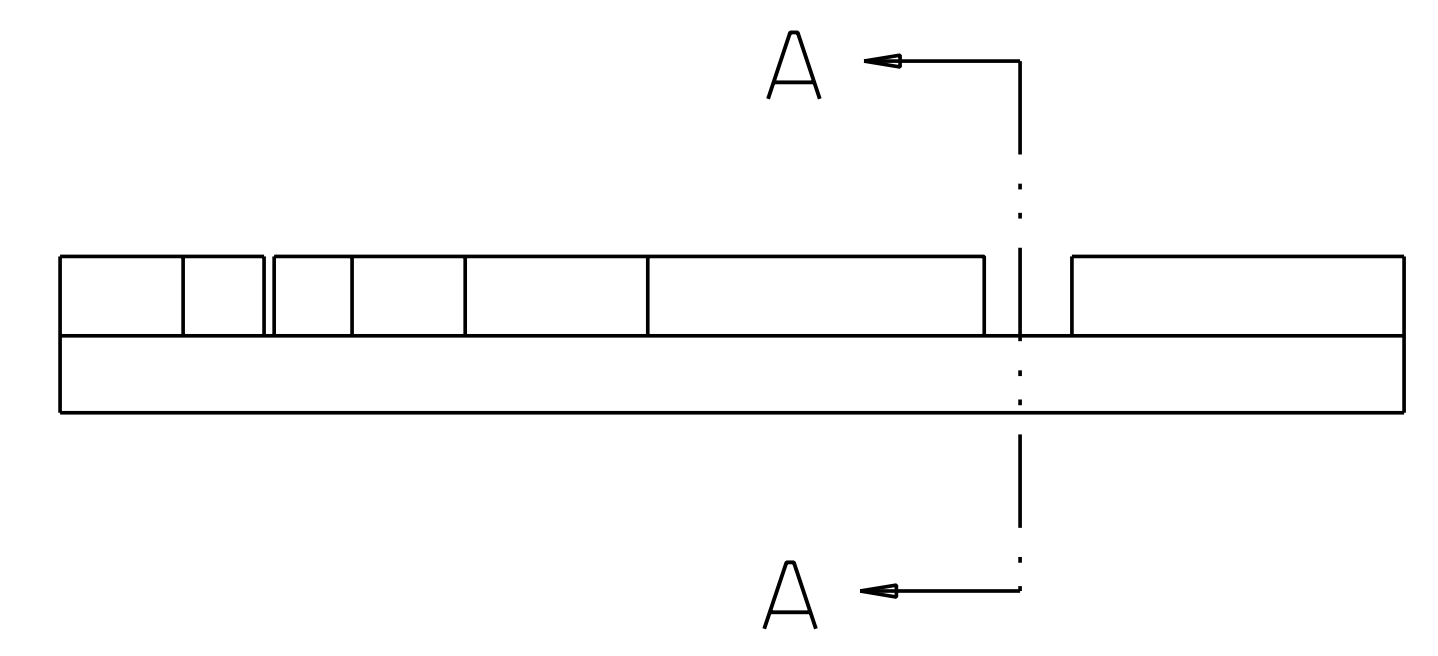
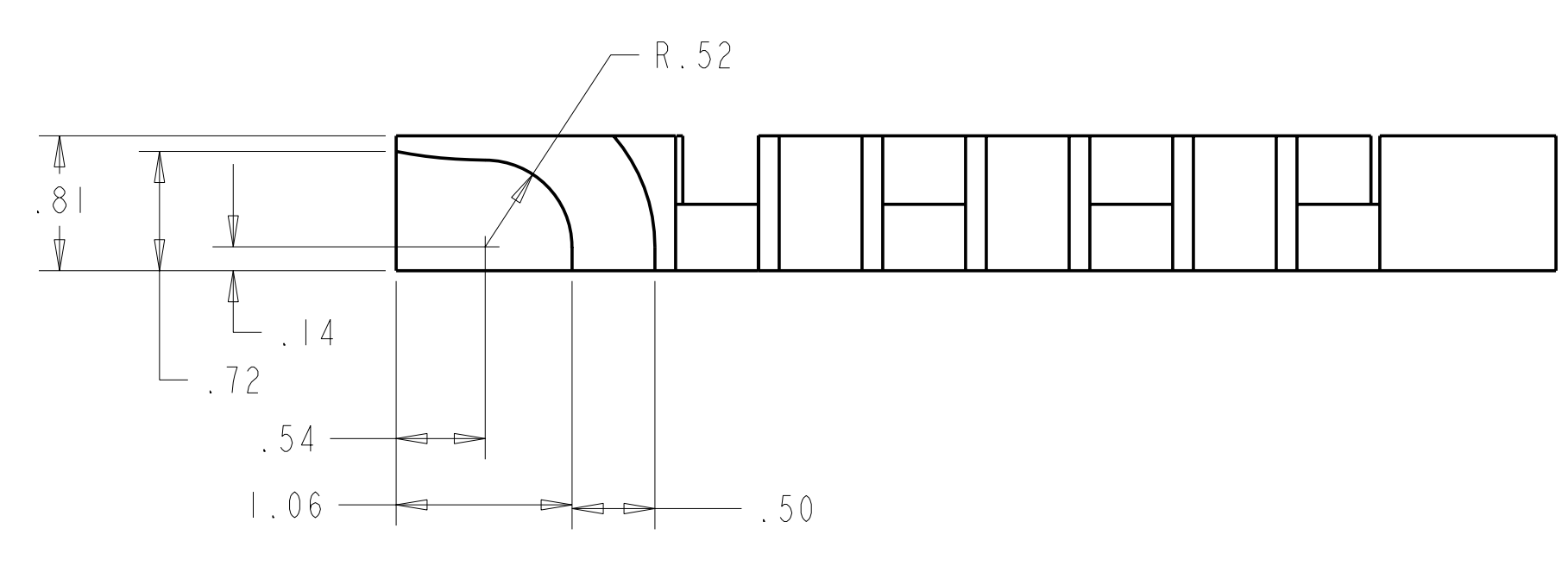
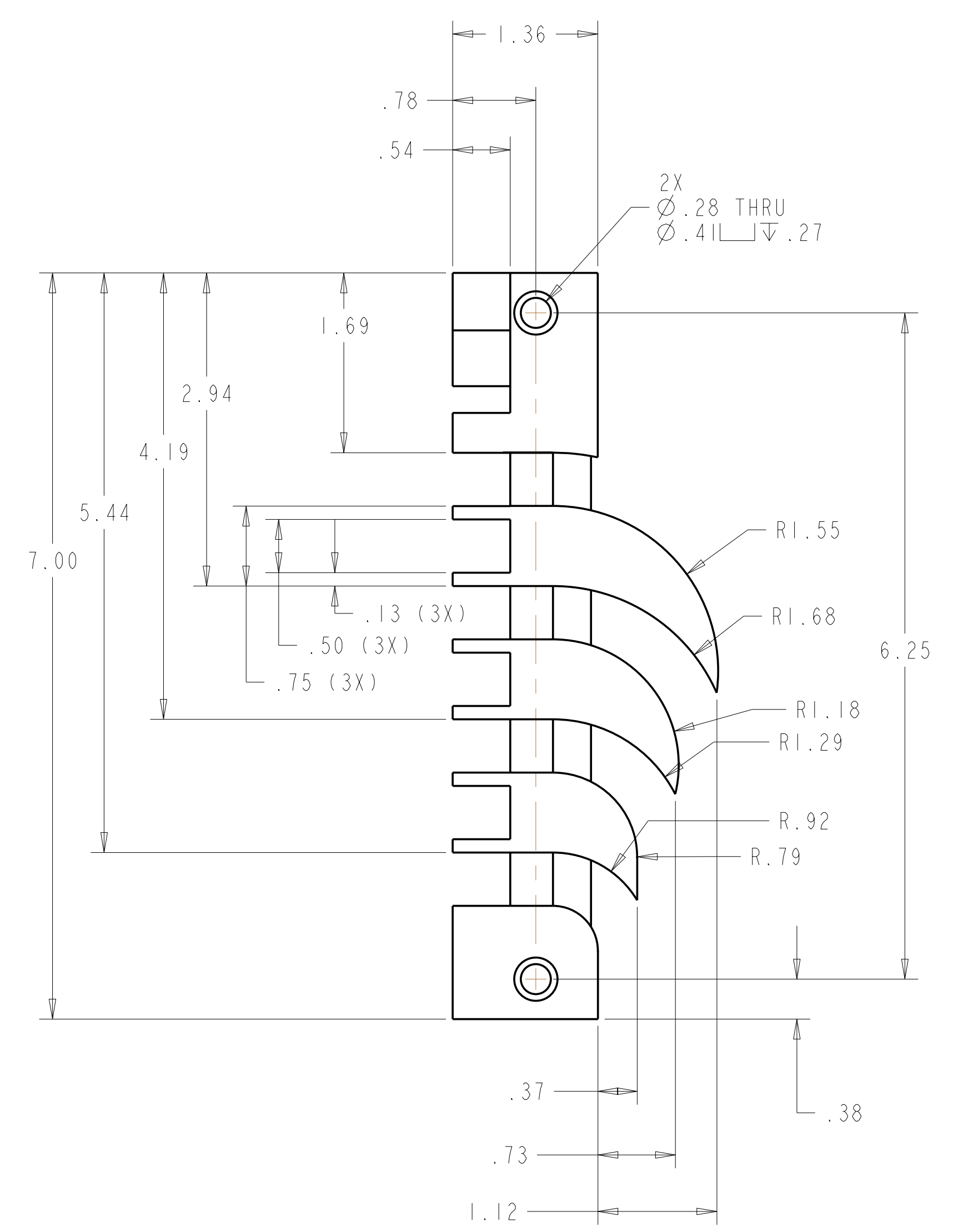

SECTION A-A

next assy	CAGE CODE	PART OR IDENTIFYING NO	NOMENCLATURE OR DESCRIPTION	SLA	MATERIAL	SPECIFICATION	FIND NO
SE1406-010			NEXT ASSEMBLY				

PARTS LIST

FOR INFORMATION ONLY  
 NOT APPROVED FOR FABRICATION

NO REPRESENTATION OR WARRANTY, EXPRESSED OR IMPLIED, IS MADE AS TO THE ACCURACY, COMPLETENESS OR USEFULNESS OF THE INFORMATION OR STATEMENTS CONTAINED IN THESE DRAWINGS, OR THAT THE USE OR DISCLOSURE OF ANY INFORMATION, APPARATUS, METHOD OR PROCESS DISCLOSED IN THESE DRAWINGS MAY NOT INFRINGE PRIVATE RIGHTS OF OTHERS. NO LIABILITY IS ASSUMED WITH RESPECT TO THE USE OF, OR FOR DAMAGES RESULTING FROM THE USE OF, ANY INFORMATION, APPARATUS, METHOD OR PROCESS DISCLOSED IN THESE DRAWINGS. DRAWINGS MADE AVAILABLE FOR INFORMATION TO BIDDER ARE NOT TO BE USED FOR OTHER PURPOSES, AND ARE TO BE RETURNED UPON REQUEST OF THE FORWARDING CONTRACTOR.

**P** THIS DRAWING PRODUCED ON PRO-ENGINEER

REV	DESCRIPTION	BY	DATE	CHK	DEPT	DATE	PE	REQ	DATE	DRNL	DOE	DATE

SCALE	1:1	DES	PJ FOGARTY	8-03-04
		DRW	G LOVETT	8-03-04
		CHK	G JONES	8-3-04
		SECT		
		DEPT		
		PE	D WILLIAMSON	8-3-04
		CR		
		PJ		
		REQ		
		PPPL	DRFT	

Oak Ridge National Laboratory managed for the DEPARTMENT OF ENERGY under U.S. GOVERNMENT CONTRACT DE-AC05-00OR22725 UT-BATTELLE, LLC, Oak Ridge, Tennessee							
<b>UT-BATTELLE</b> NATIONAL COMPACT STELLARATOR EXPERIMENT							
BLOCK WINDING LOWER MIRROR							
VERSION NO.	PLANT	BLDG	FL	SHT OF	TYPE	CLASS	
2+	X-10	5700	3	1	I	S	U
RELEASE LEVEL	SE1406-123			REV	0		
WIP							

- NOTES:
1. INTERPRET DIMENSIONS AND TOLERANCES PER ANSI Y14.5M
  2. DIMENSIONS ARE IN INCHES
  3. DIMENSIONS APPLY AT ROOM TEMPERATURE. OPERATING TEMP 80 K.
  4. GEOMETRY IS DEFINED IN PRO ENGINEER CAD MODELS/FILES SE1406-134.PRT
  5. DRAWING AND MODELS COMBINED DEFINE FINISHED MACHINED PART.
  6. TOLERANCE X.XXX DIMENSIONS +/- .010

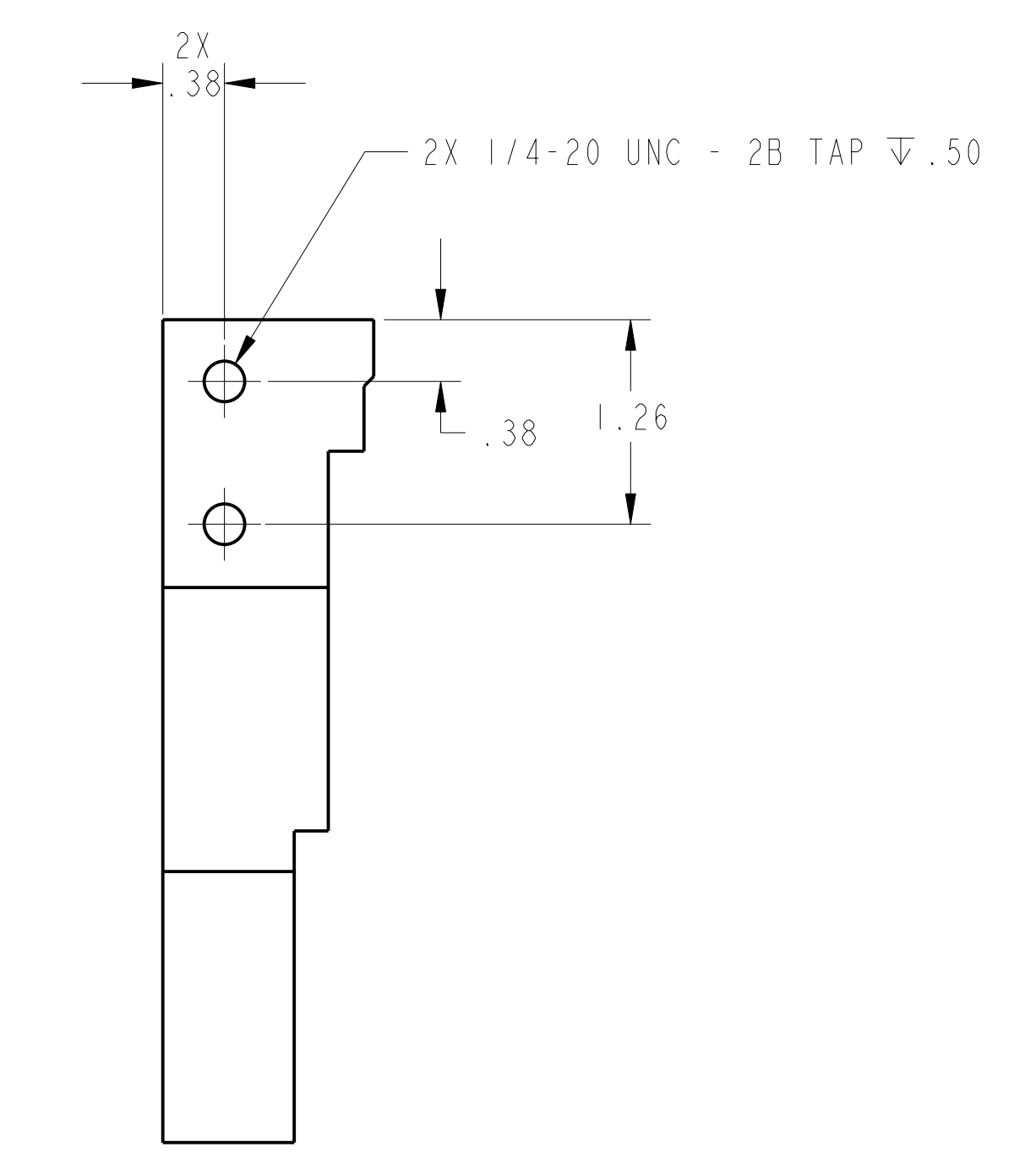
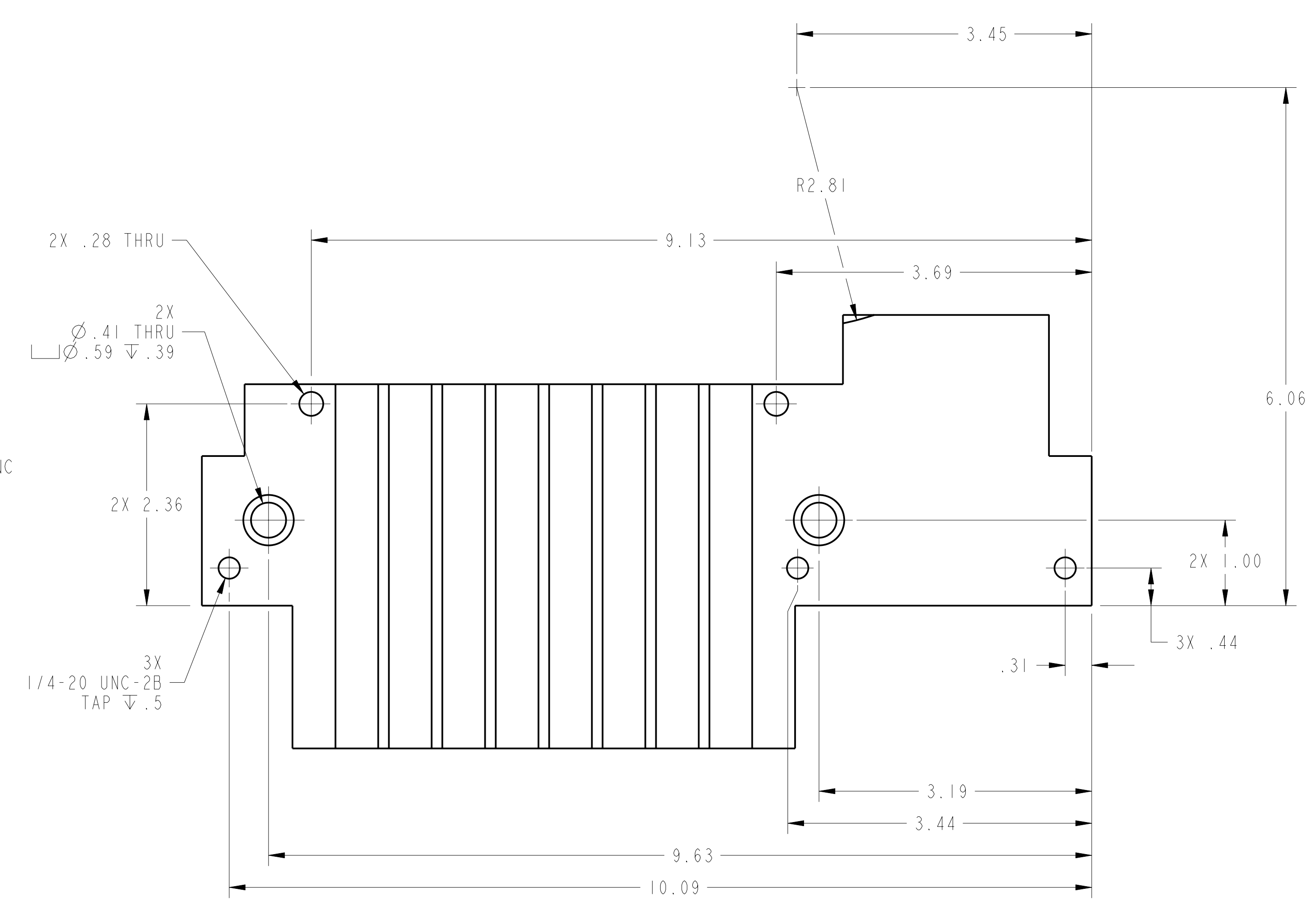
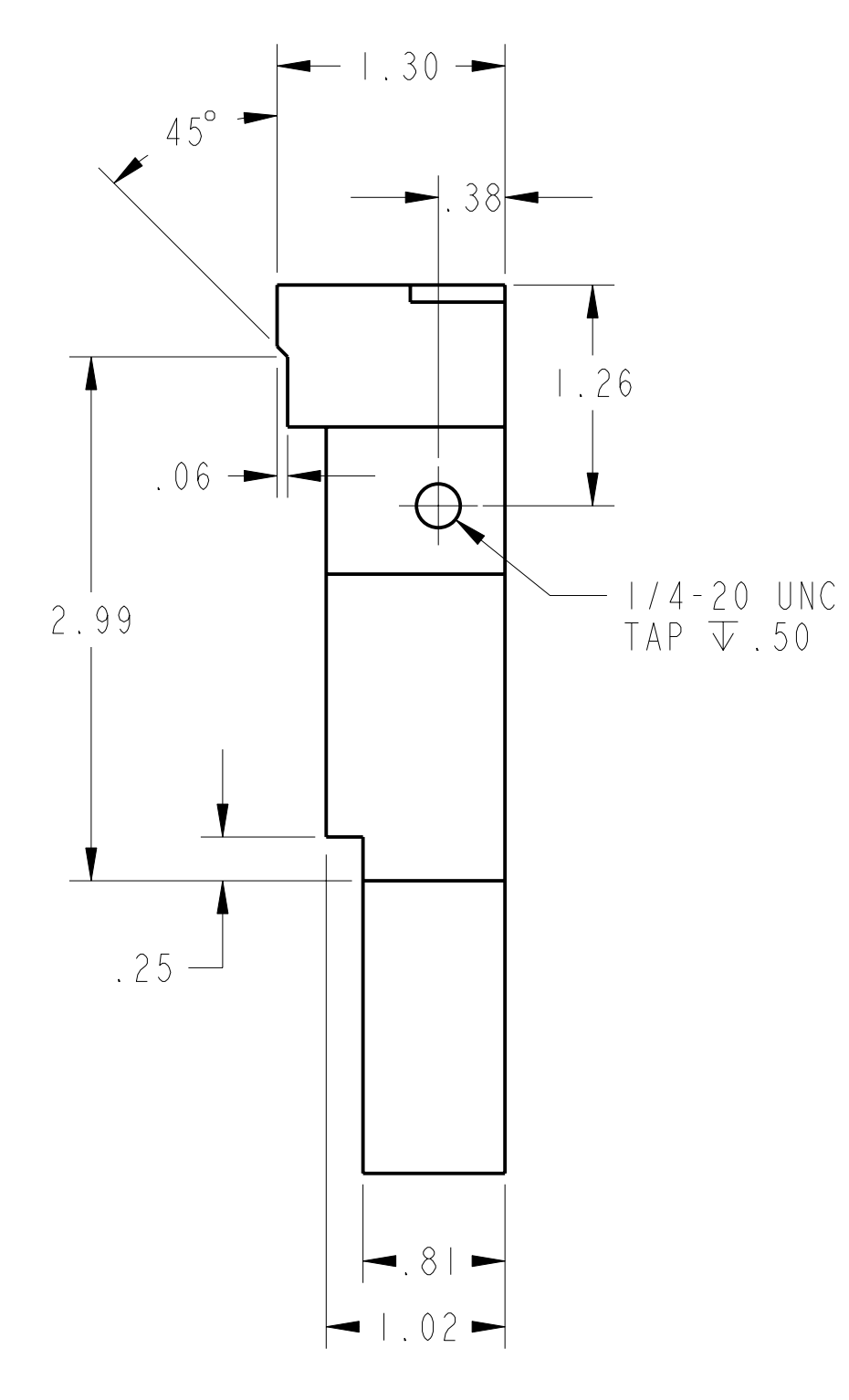
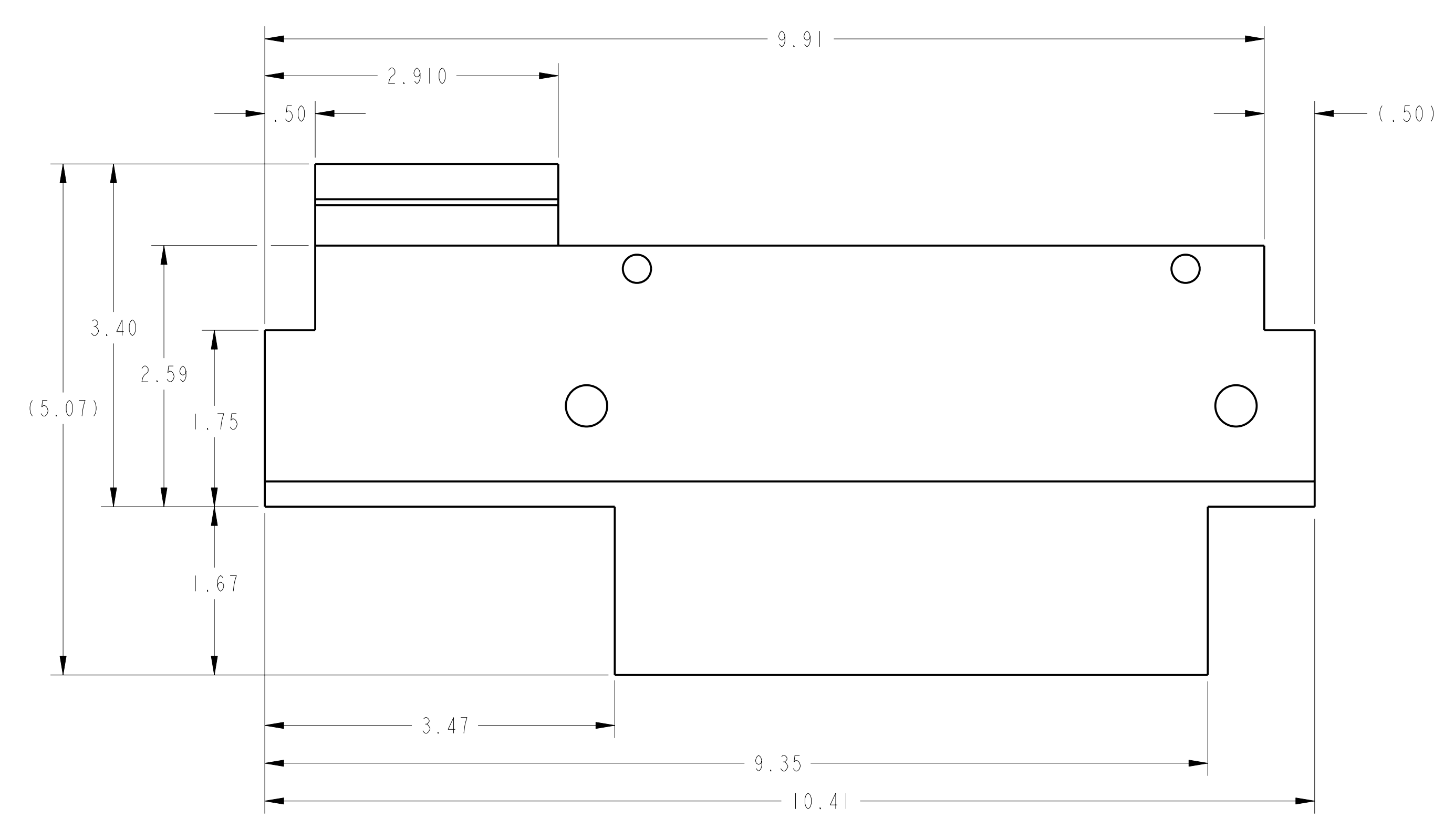
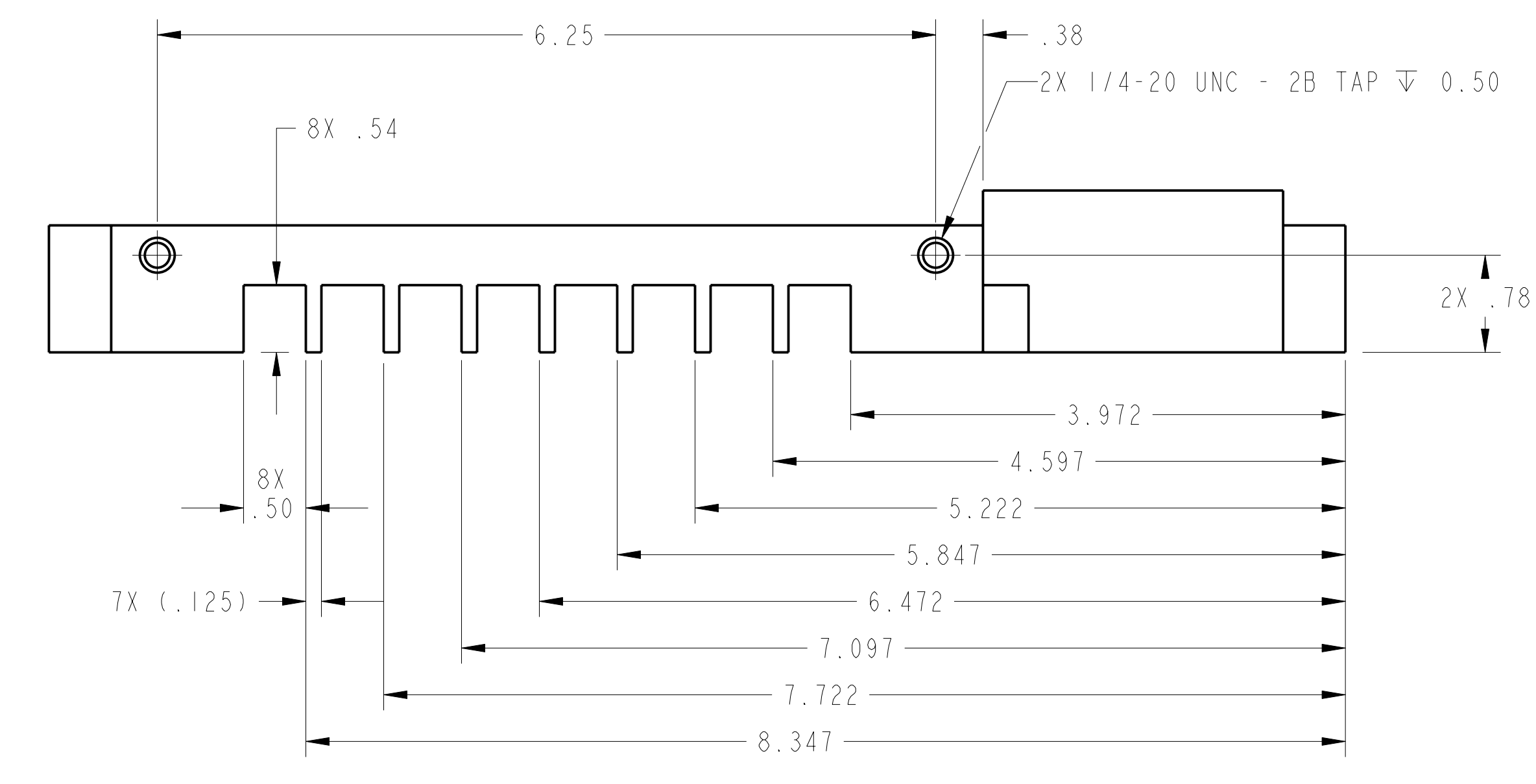
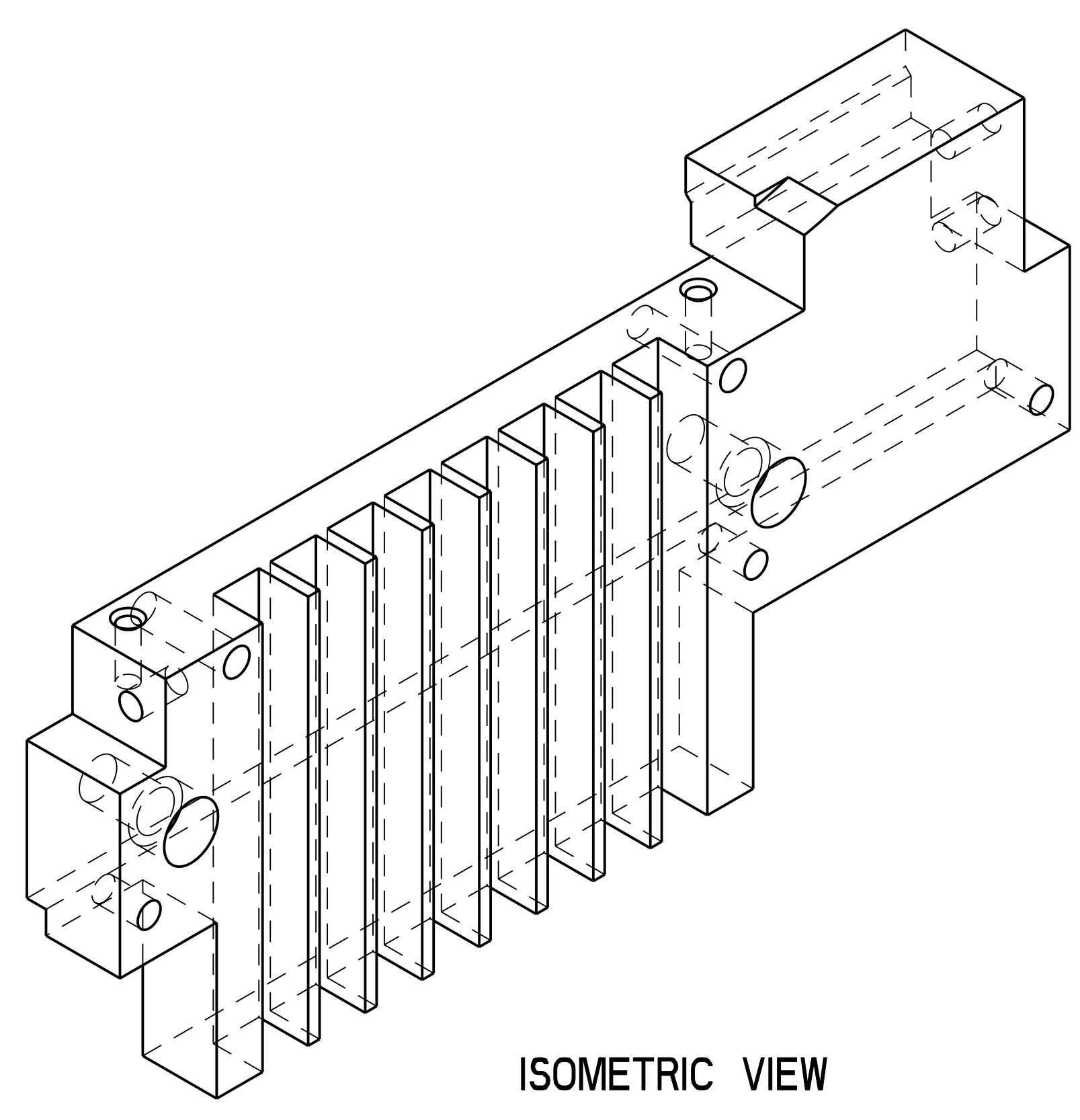

① LOWER "A" FILL BLOCK

REV	DESCRIPTION	BY	DATE	CHK	DEPT	DATE	PE	REQ	DATE	ORNL	DOE	DATE

next assy	CAGE CODE	PART OR IDENTIFYING NO	NOMENCLATURE OR DESCRIPTION	MATERIAL	SPECIFICATION	FIND NO
SE1406-010			LOWER "A" FILL BLOCK	G10		

← NEXT ASSEMBLY

PARTS LIST

FOR INFORMATION ONLY  
NOT APPROVED FOR FABRICATION

NO REPRESENTATION OR WARRANTY, EXPRESSED OR IMPLIED, IS MADE AS TO THE ACCURACY, COMPLETENESS OR USEFULNESS OF THE INFORMATION OR STATEMENTS CONTAINED IN THESE DRAWINGS, OR THAT THE USE OR DISCLOSURE OF ANY INFORMATION, APPARATUS, METHOD OR PROCESS DISCLOSED IN THESE DRAWINGS MAY NOT INFRINGE PRIVATE RIGHTS OF OTHERS. NO LIABILITY IS ASSUMED WITH RESPECT TO THE USE OF, OR FOR DAMAGES RESULTING FROM THE USE OF, ANY INFORMATION, APPARATUS, METHOD OR PROCESS DISCLOSED IN THESE DRAWINGS. DRAWINGS MADE AVAILABLE FOR INFORMATION TO BIDDER ARE NOT TO BE USED FOR OTHER PURPOSES, AND ARE TO BE RETURNED UPON REQUEST OF THE FORWARDING CONTRACTOR.

**P** THIS DRAWING PRODUCED ON PRO-ENGINEER

SCALE 1:1

TOLERANCES UNLESS OTHERWISE SPECIFIED

FRACTIONS ±.01  
XX DECIMALS ±.005  
XXX DECIMALS ±.0015  
ANGLES ±0'15"  
BREAK SHARP EDGES OR MAX  
FINISH .125 UNLESS OTHERWISE SPECIFIED

DES PJ FOGARTY 10/11/04  
DRW T HARGROVE 10/12/04  
CHK M COLE 10/11/04  
SECT :  
DEPT :  
PE D WILLIAMSON 10/11/04  
CR :  
PJ :  
REQ :  
REV :  
PPPL DRFT J SIEGEL 10/11/04

Oak Ridge National Laboratory  
managed for the DEPARTMENT OF ENERGY under  
U.S. GOVERNMENT contract DE-AC05-00OR22725  
UT-BATTELLE, LLC. Oak Ridge, Tennessee  
PROJECT NAME  
**NATIONAL COMPACT STELLARATOR EXPERIMENT**

TRC FILL BLOCK  
LOWER "A"

VERSION NO.	PLANT	BLDG	FL	SHT	OF	TYPE	CLASS
12+	X-10	5700	3	1	1	S	U

RELEASE LEVEL  
WIP

SE1406-134

REV 0

- NOTES:
1. INTERPRET DIMENSIONS AND TOLERANCES PER ANSI Y14.5M
  2. DIMENSIONS ARE IN INCHES
  3. DIMENSIONS APPLY AT ROOM TEMPERATURE. OPERATING TEMP 80 K.
  4. GEOMETRY IS DEFINED IN PRO ENGINEER CAD MODELS/FILES SEI406-135.PRT
  5. DRAWING AND MODELS COMBINED DEFINE FINISHED MACHINED PART.
  6. TOLERANCE X.XXX DIMENSIONS +/- .010

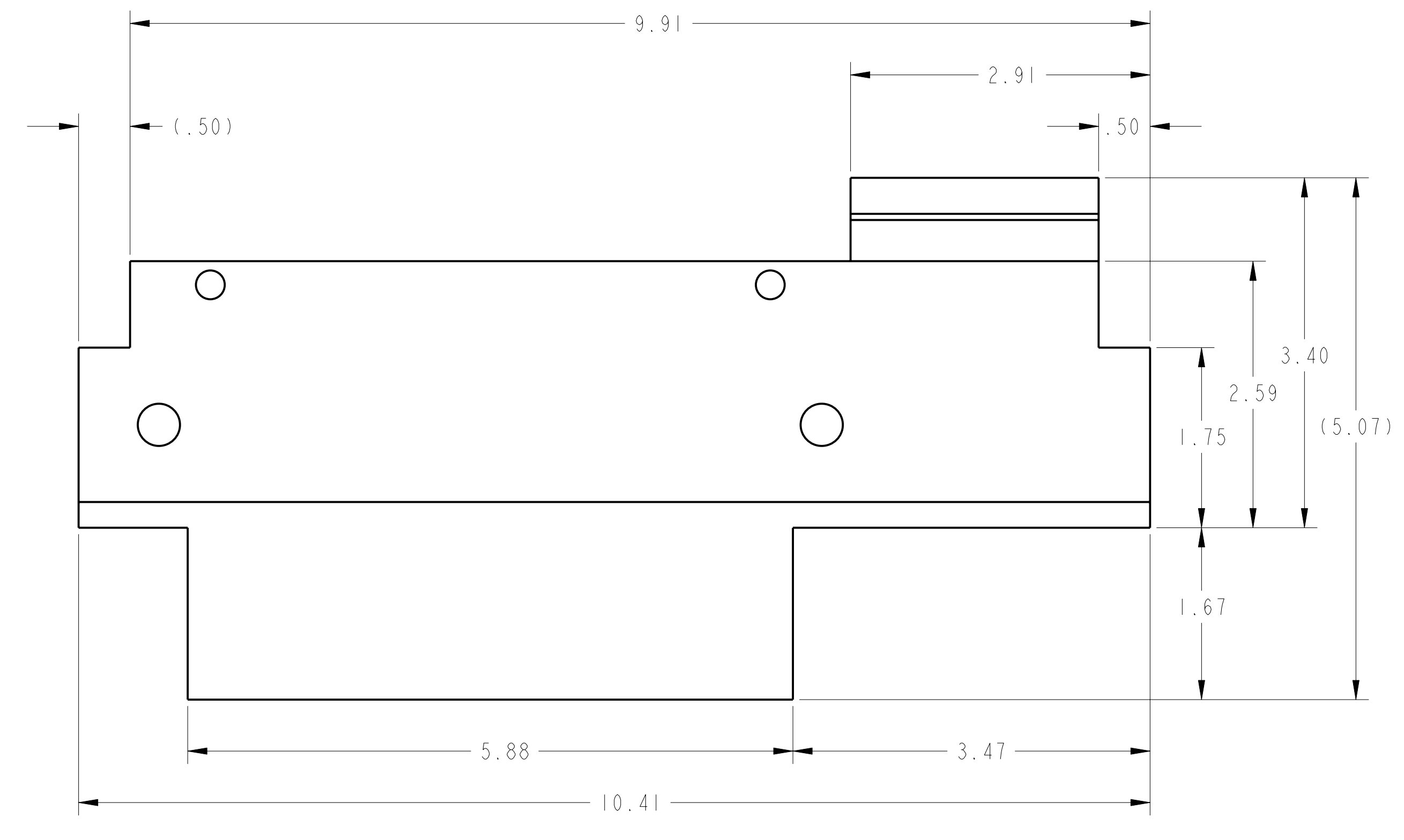
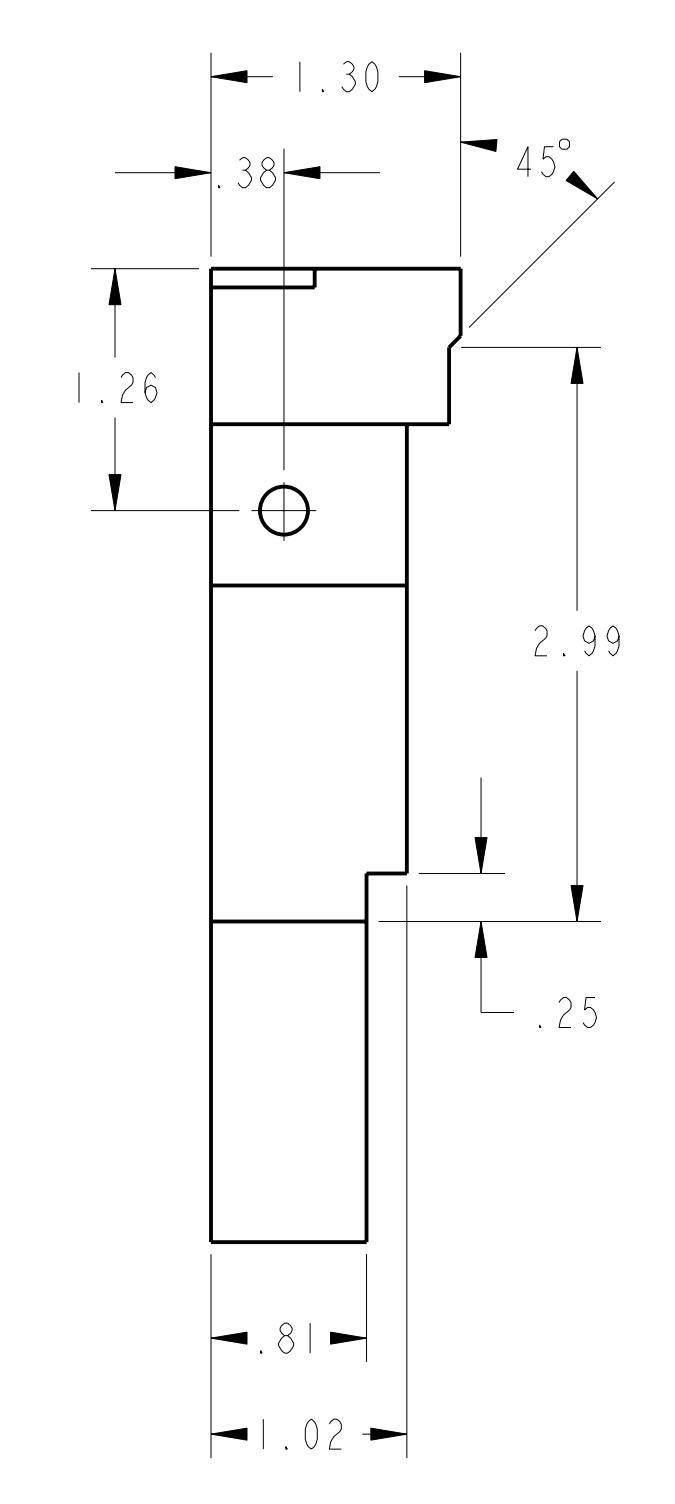
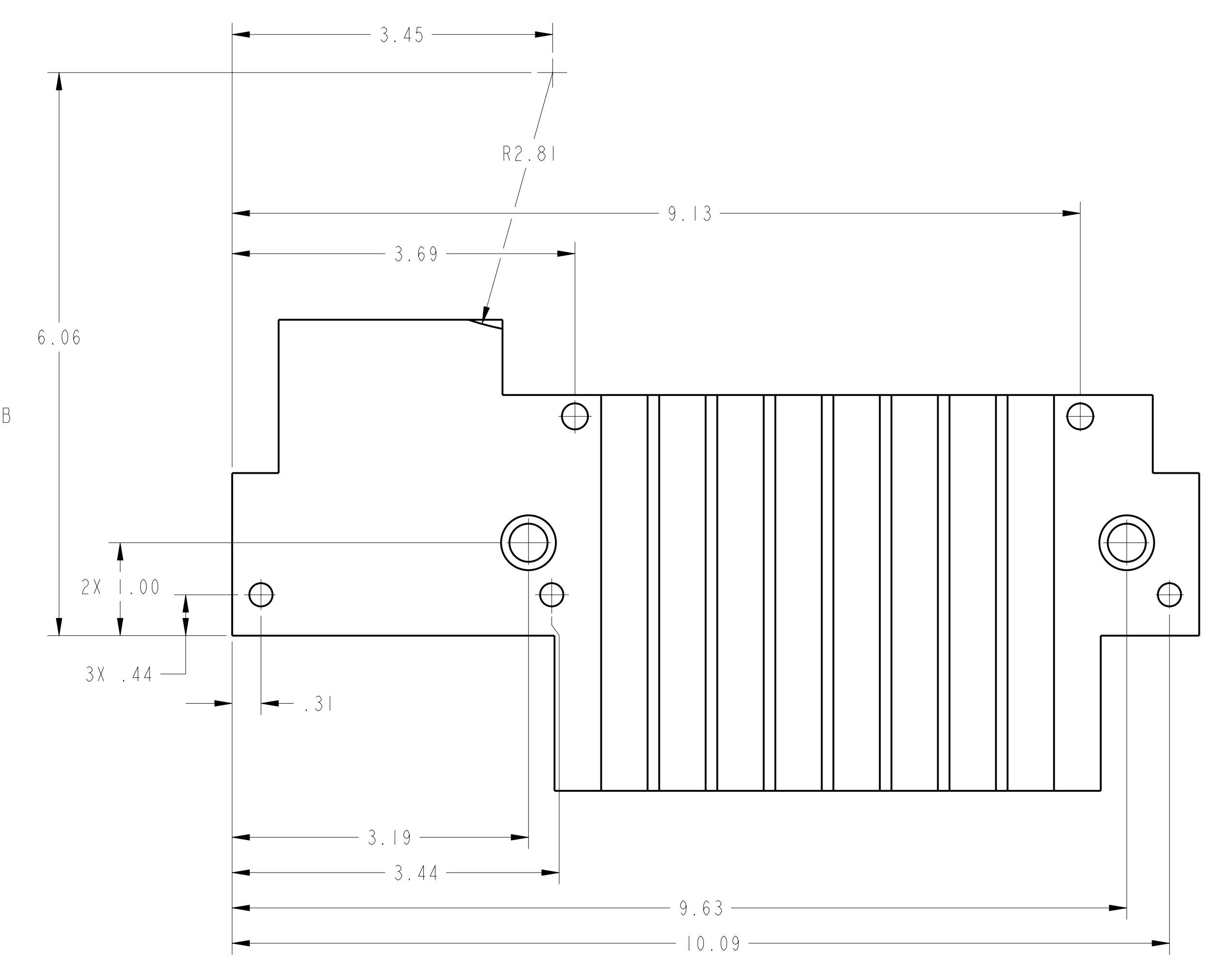
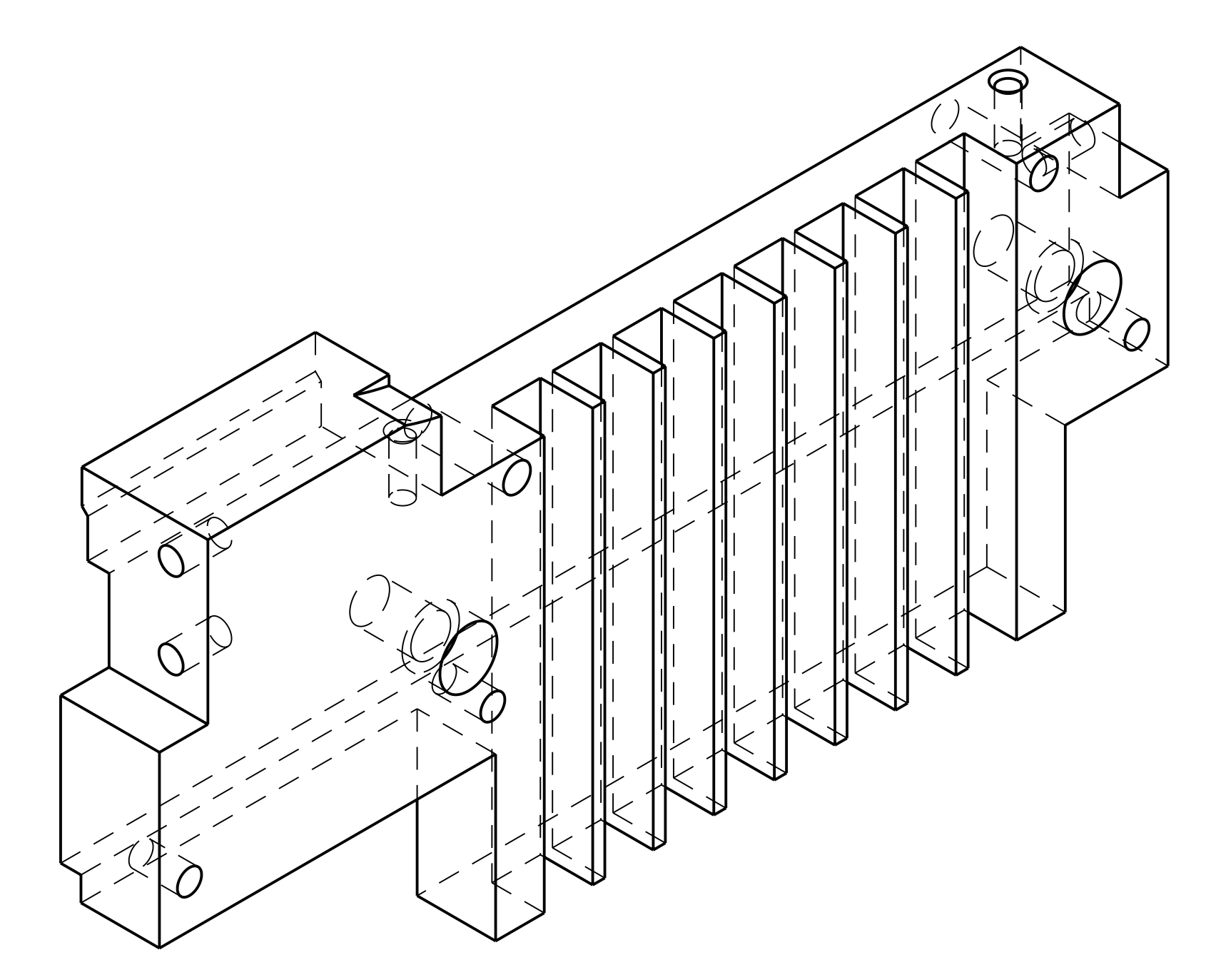
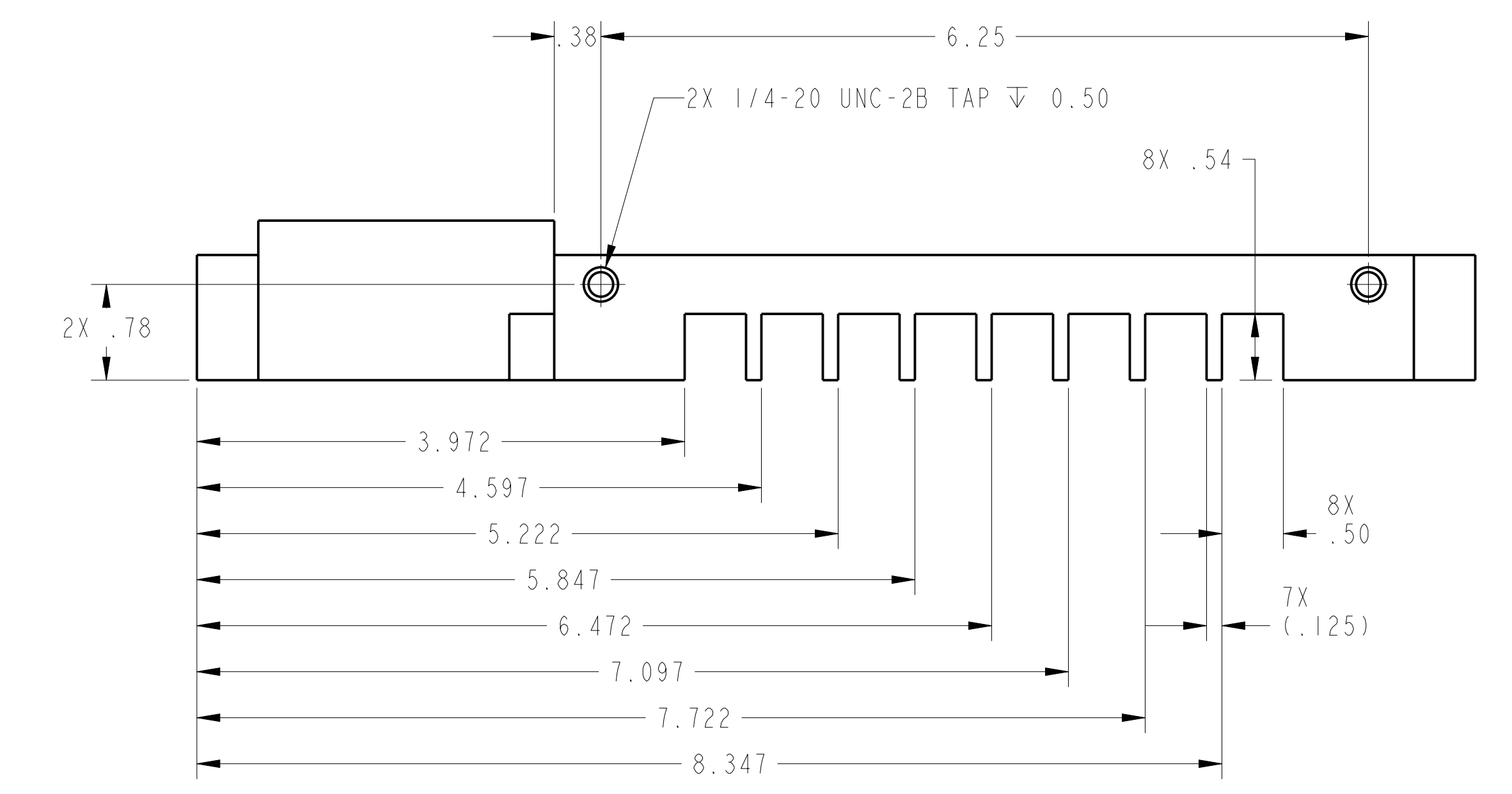

① LOWER "B" FILL BLOCK

next assy	CAGE CODE	PART OR IDENTIFYING NO	NOMENCLATURE OR DESCRIPTION	MATERIAL	SPECIFICATION	FIND NO
SEI406-010			LOWER "B" FILL BLOCK	G10		

← NEXT ASSEMBLY

PARTS LIST

FOR INFORMATION ONLY  
NOT APPROVED FOR FABRICATION

NO REPRESENTATION OR WARRANTY, EXPRESSED OR IMPLIED, IS MADE AS TO THE ACCURACY, COMPLETENESS OR USEFULNESS OF THE INFORMATION OR STATEMENTS CONTAINED IN THESE DRAWINGS, OR THAT THE USE OR DISCLOSURE OF ANY INFORMATION, APPARATUS, METHOD OR PROCESS DISCLOSED IN THESE DRAWINGS MAY NOT INFRINGE PRIVATE RIGHTS OF OTHERS. NO LIABILITY IS ASSUMED WITH RESPECT TO THE USE OF, OR FOR DAMAGES RESULTING FROM THE USE OF, ANY INFORMATION, APPARATUS, METHOD OR PROCESS DISCLOSED IN THESE DRAWINGS. DRAWINGS MADE AVAILABLE FOR INFORMATION TO BIDDER ARE NOT TO BE USED FOR OTHER PURPOSES, AND ARE TO BE RETURNED UPON REQUEST OF THE FORWARDING CONTRACTOR.

**P** THIS DRAWING PRODUCED ON PRO-ENGINEER

REV	DESCRIPTION	BY	DATE	CHK	DEPT	DATE	PE	REQ	DATE	ORNL	DOE	DATE
	REVISION OR ISSUE PURPOSE											

SCALE 1:1	DES PJ FPGARTY 10-1-04
TOLERANCES UNLESS OTHERWISE SPECIFIED	DRW T HARGROVE 10-12-04
FRACTIONS	CHK M COLE 10-14-04
XX DECIMALS ±.01	DEPT :
XXX DECIMALS ±.005	PE D WILLIAMSON 10-14-04
ANGLES ±0°15'	CR :
BREAK SHARP EDGES OR MAX	PJ :
FINISH .125 UNLESS OTHERWISE SPECIFIED	REQ :
	PPPL DRFT J SIEGEL 10-14-04
	VERSION NO. 3+
	PLANT X-10
	BLDG 5700
	FL 3
	SHT 1
	OF 1
	TYPE I
	CLASS S
	U
	REV 0

Oak Ridge National Laboratory managed for the DEPARTMENT OF ENERGY under U.S. GOVERNMENT contract DE-AC05-00OR22725 UT-BATTELLE, LLC. Oak Ridge, Tennessee	
PROJECT NAME <b>NATIONAL COMPACT STELLARATOR EXPERIMENT</b>	
TRC FILL BLOCK LOWER "B"	
RELEASE LEVEL WIP	SEI406-135

- NOTES:
1. INTERPRET DIMENSIONS AND TOLERANCES PER ANSI Y14.5M
  2. DIMENSIONS ARE IN INCHES
  3. DIMENSIONS APPLY AT ROOM TEMPERATURE. OPERATING TEMP 80 K.
  4. GEOMETRY IS DEFINED IN PRO ENGINEER CAD MODELS/FILES SE1406-136.PRT
  5. DRAWING AND MODELS COMBINED DEFINE FINISHED MACHINED PART.
  6. TOLERANCE X.XXX DIMENSIONS +/- .010

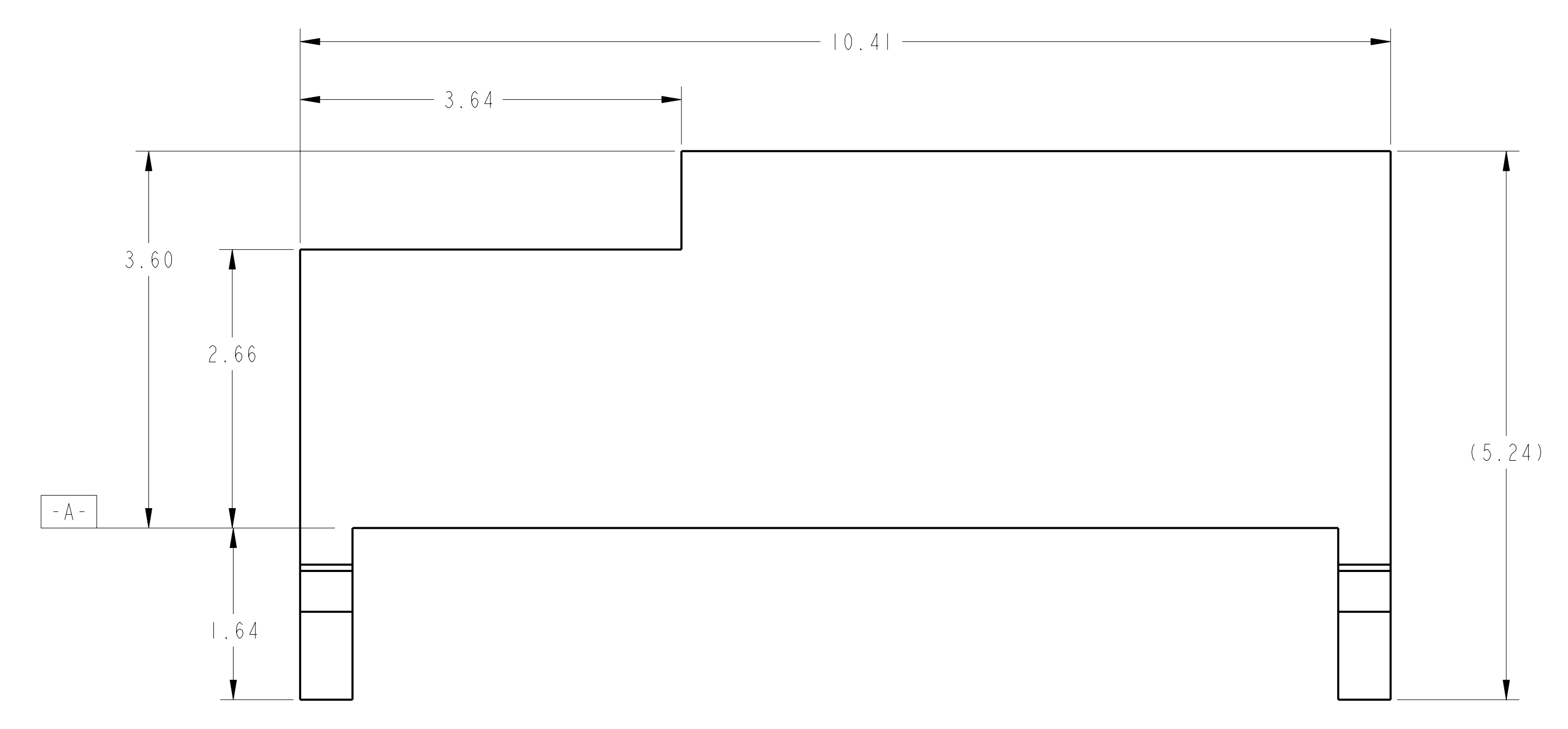
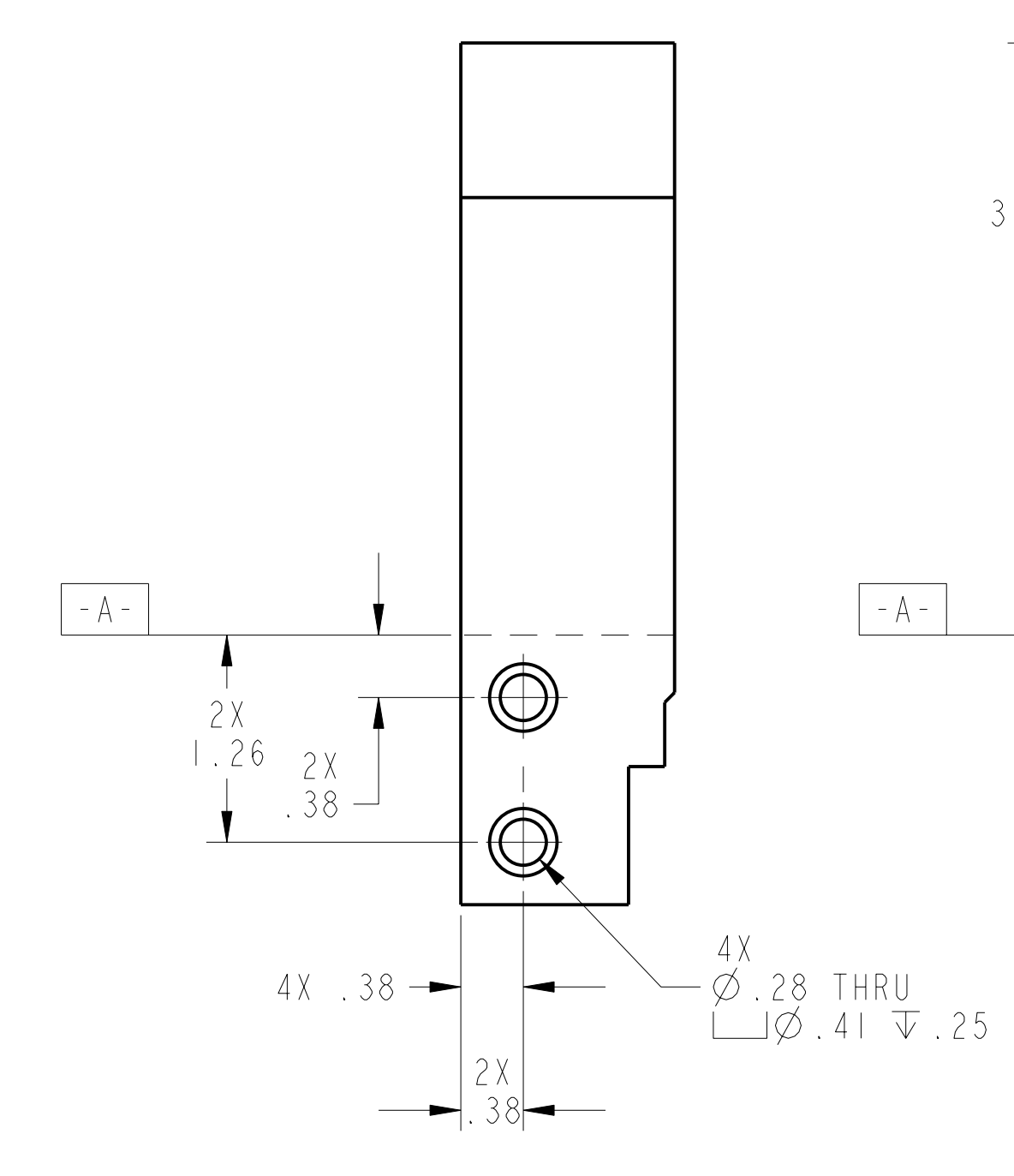
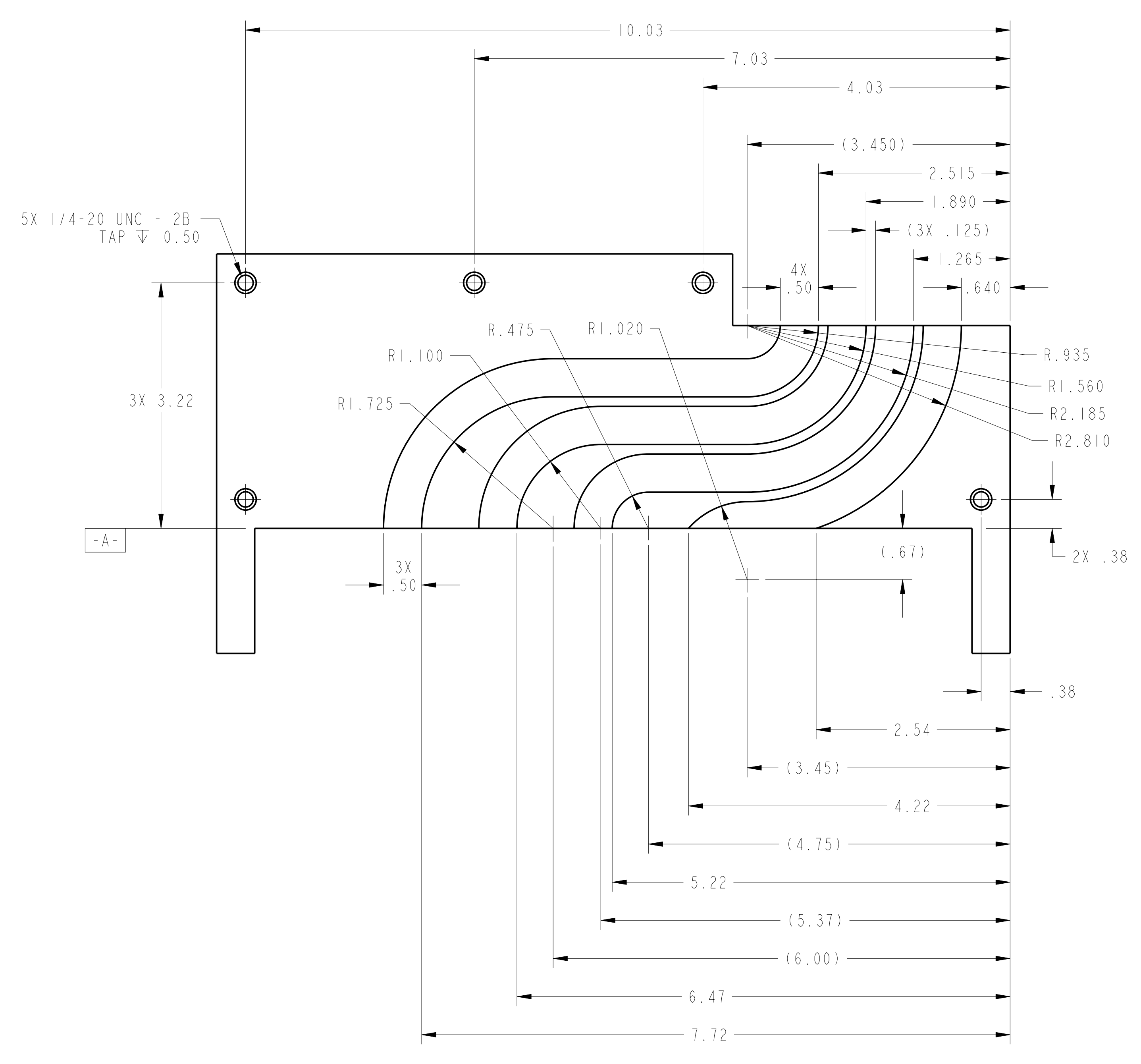
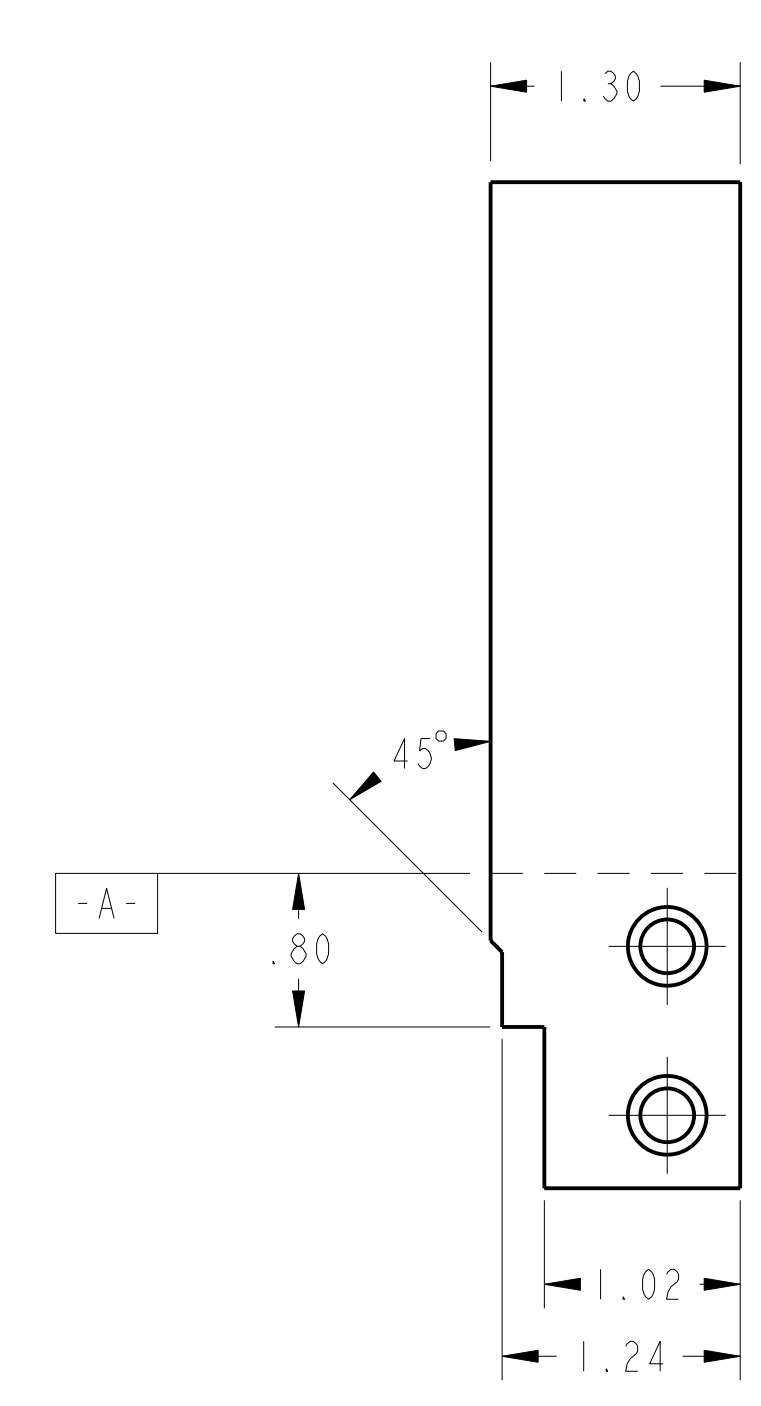
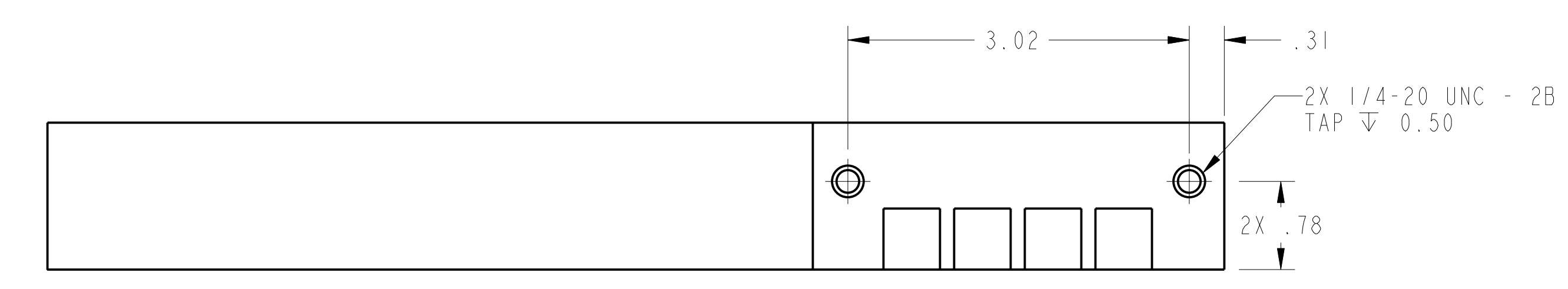
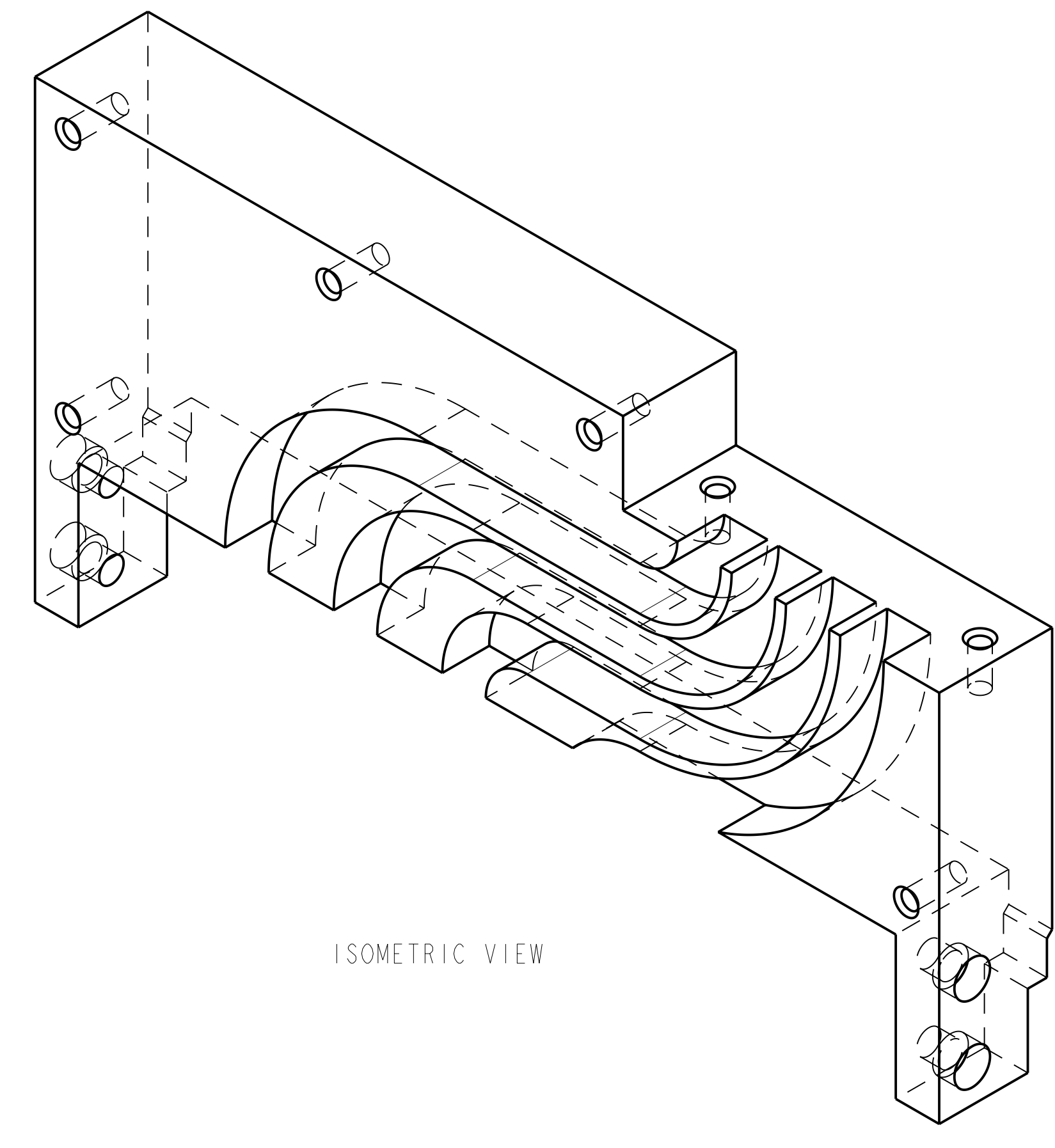

1 UPPER "A" FILL BLOCK

next assy	CAGE CODE	PART OR IDENTIFYING NO	NOMENCLATURE OR DESCRIPTION	MATERIAL	SPECIFICATION	FIND NO
SE1406-010			UPPER "A" FILL BLOCK	G10		
			NEXT ASSEMBLY			

PARTS LIST

NO REPRESENTATION OR WARRANTY, EXPRESSED OR IMPLIED, IS MADE AS TO THE ACCURACY, COMPLETENESS OR USEFULNESS OF THE INFORMATION OR STATEMENTS CONTAINED IN THESE DRAWINGS, OR THAT THE USE OR DISCLOSURE OF ANY INFORMATION, APPARATUS, METHOD OR PROCESS DISCLOSED IN THESE DRAWINGS MAY NOT INFRINGE PRIVATE RIGHTS OF OTHERS. NO LIABILITY IS ASSUMED WITH RESPECT TO THE USE OF, OR FOR DAMAGES RESULTING FROM THE USE OF, ANY INFORMATION, APPARATUS, METHOD OR PROCESS DISCLOSED IN THESE DRAWINGS. DRAWINGS MADE AVAILABLE FOR INFORMATION TO BIDDER ARE NOT TO BE USED FOR OTHER PURPOSES, AND ARE TO BE RETURNED UPON REQUEST OF THE FORWARDING CONTRACTOR.

**P** THIS DRAWING PRODUCED ON PRO-ENGINEER

REV	DESCRIPTION	BY	DATE	CHK	DEPT	DATE	PE	REQ	DATE	ORNL	DOE	DATE
	REVISION OR ISSUE PURPOSE											

SCALE 1:1	DES PJ FOGARTY 10-1-04	<b>UT-BATTELLE</b> Oak Ridge National Laboratory managed for the DEPARTMENT OF ENERGY under U.S. GOVERNMENT contract DE-AC05-00OR22725 UT-BATTELLE, LLC, Oak Ridge, Tennessee PROJECT NAME <b>NATIONAL COMPACT STELLARATOR EXPERIMENT</b>							
TOLERANCES UNLESS OTHERWISE SPECIFIED	DRW T HARGROVE 10-12-04								
FRACTIONS	CHK M COLE 10-14-04								
XX DECIMALS ±.01	DEPT :								
XXX DECIMALS ±.005	PE D WILLIAMSON 10-14-04	<b>TRC FILL BLOCK</b> <b>UPPER "A"</b>							
ANGLES ±0°15'	CR :								
BREAK SHARP EDGES OR MAX	PJ :								
FINISH .125 UNLESS OTHERWISE SPECIFIED	REQ :								
	PPPL DRFT J SIEGEL 10-14-04	VERSION NO.	PLANT	BLDG	FL	SHT	OF	TYPE	CLASS
		5+	X-10	5700	3	1	1	S	U
		RELEASE LEVEL	SE1406-136						
		WIP	REV 0						

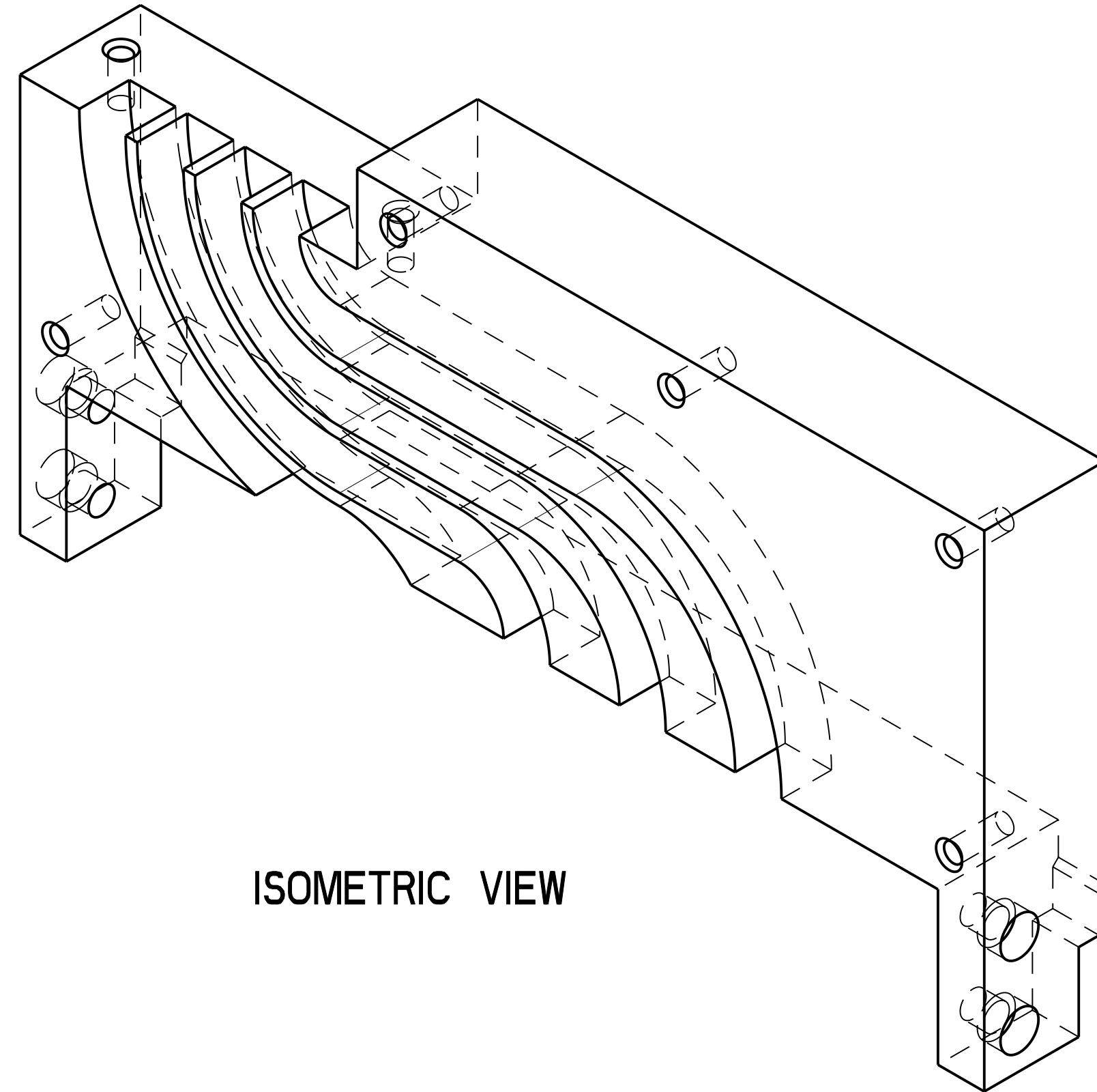

ISOMETRIC VIEW

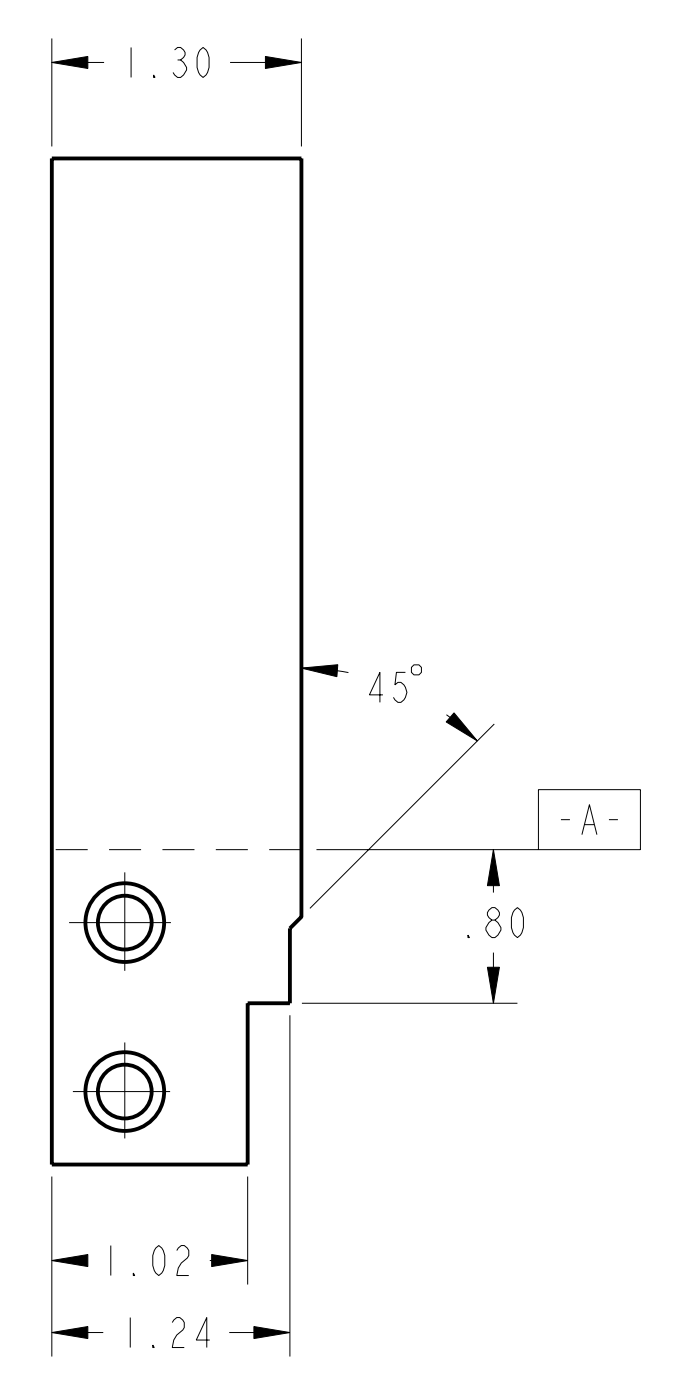
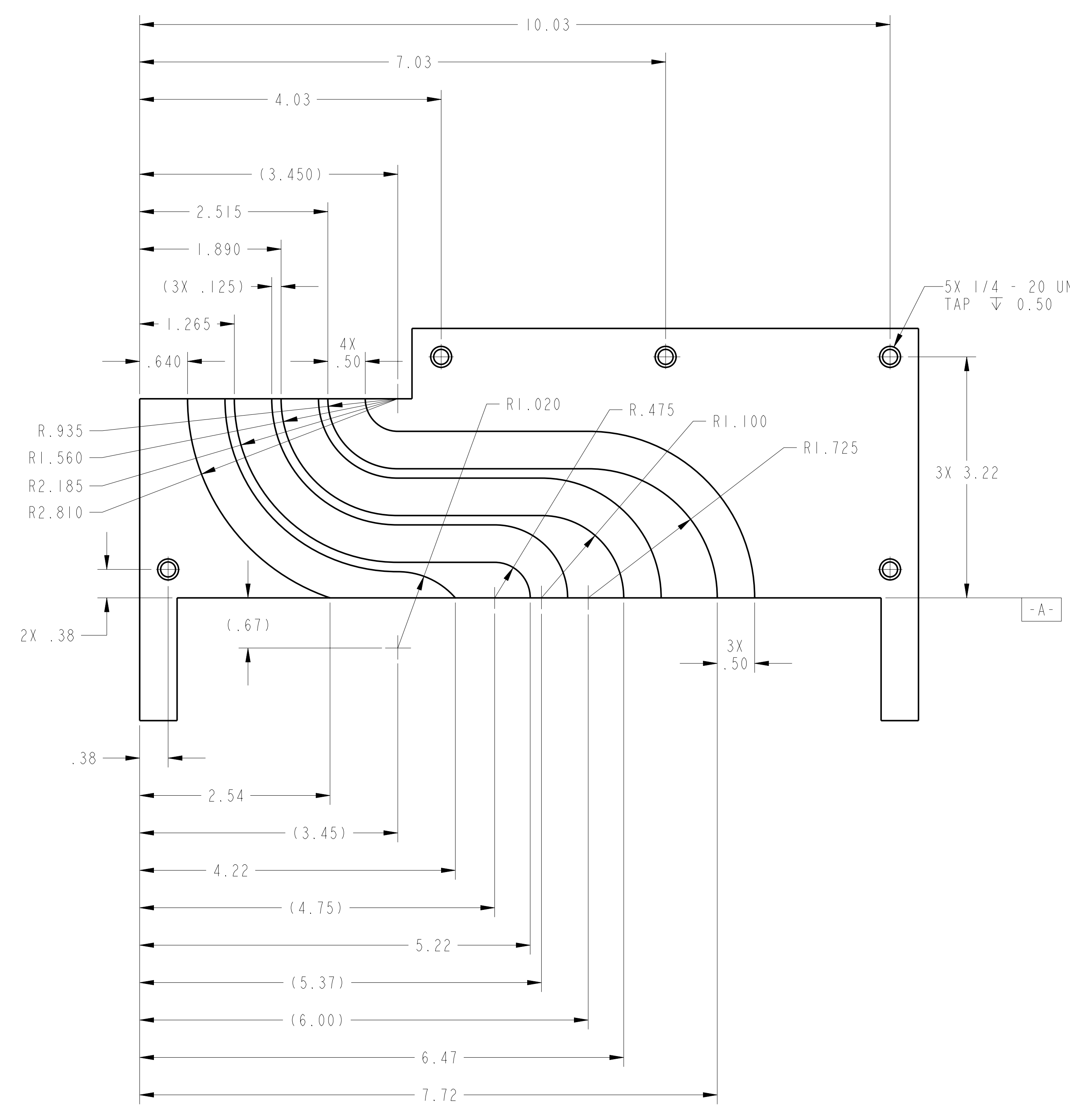
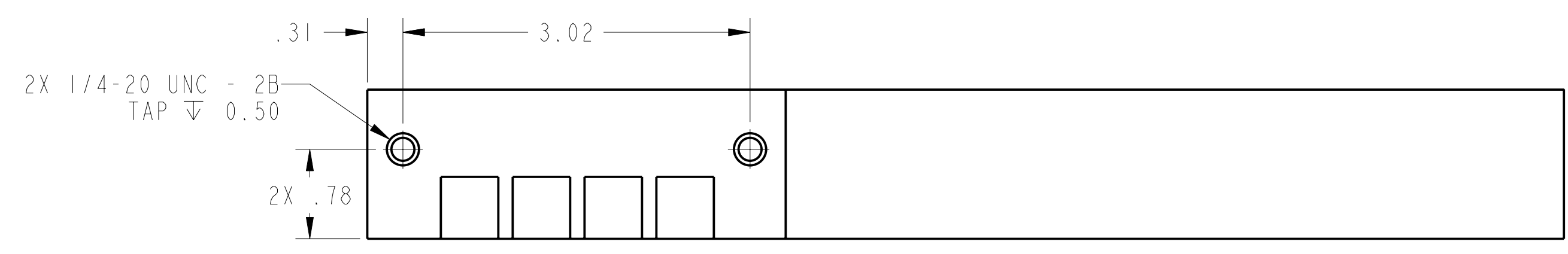
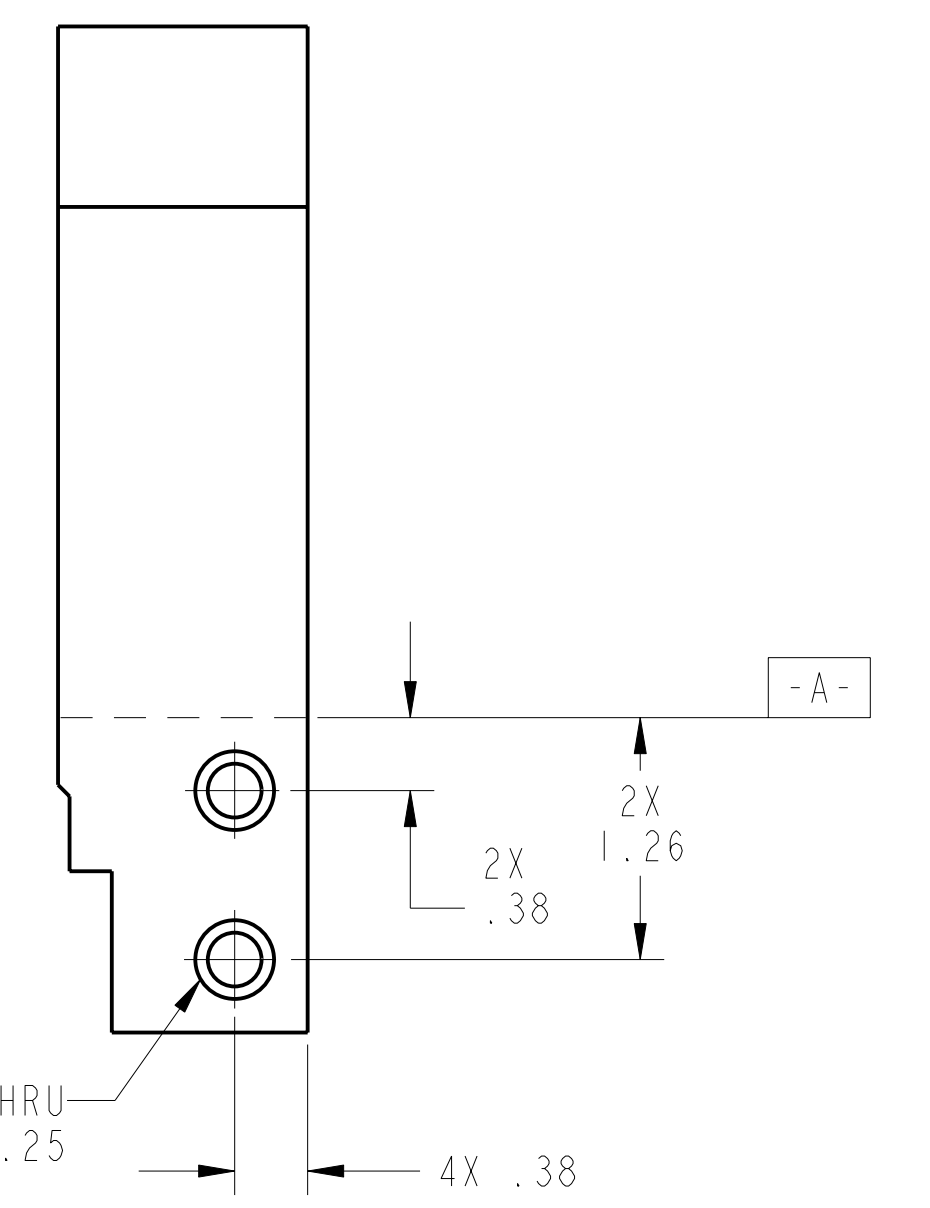
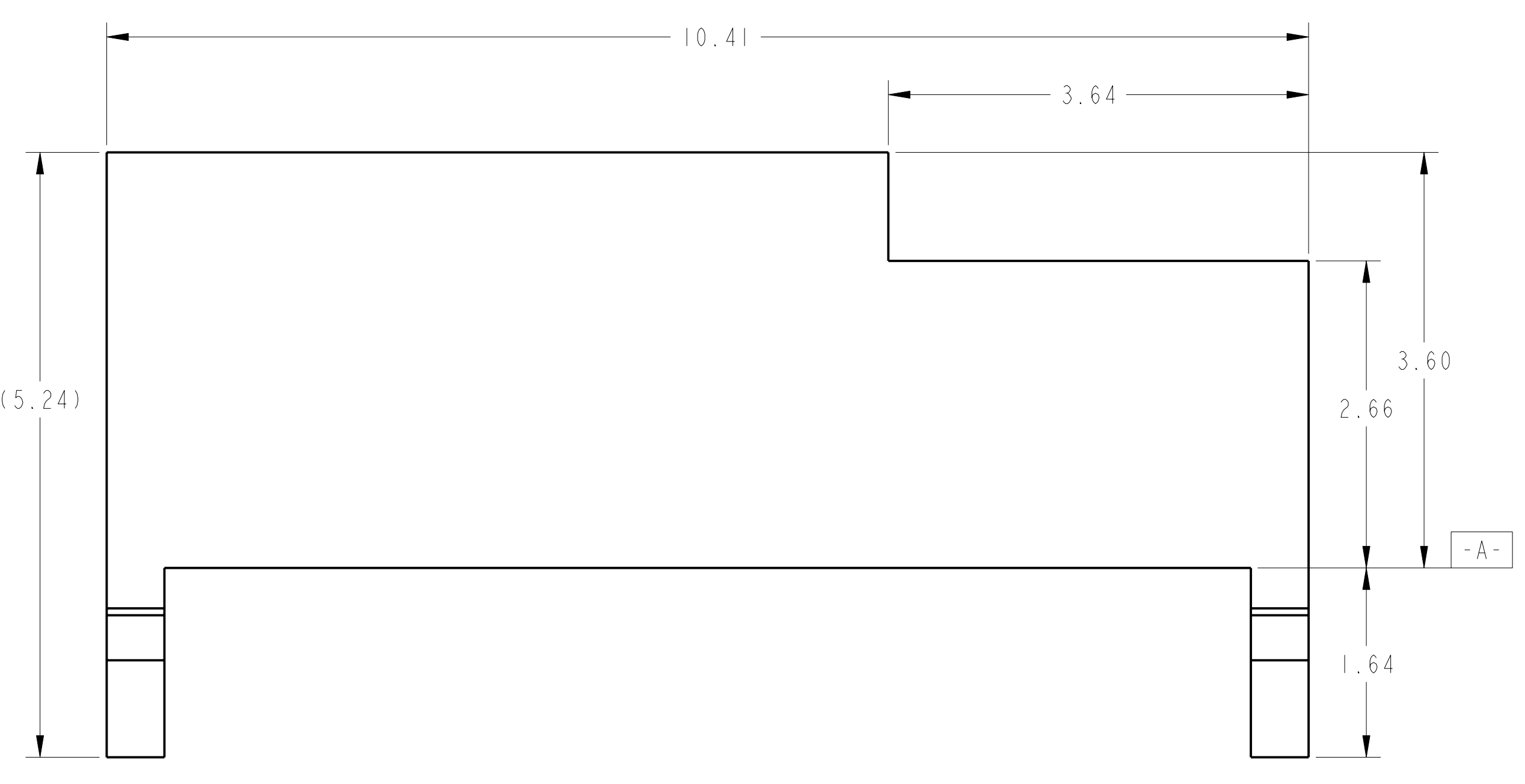

1 UPPER "B" FILL BLOCK

- NOTES:
1. INTERPRET DIMENSIONS AND TOLERANCES PER ANSI Y14.5M
  2. DIMENSIONS ARE IN INCHES
  3. DIMENSIONS APPLY AT ROOM TEMPERATURE. OPERATING TEMP 80 K.
  4. GEOMETRY IS DEFINED IN PRO ENGINEER CAD MODELS/FILES SE1406-137.PRT
  5. DRAWING AND MODELS COMBINED DEFINE FINISHED MACHINED PART.
  6. TOLERANCE X.XXX DIMENSIONS +/- .010

REV	DESCRIPTION	BY	DATE	CHK	DEPT	DATE	PE	REQ	DATE	ORNL	DOE	DATE

next assy	CAGE CODE	PART OR IDENTIFYING NO	NOMENCLATURE OR DESCRIPTION	MATERIAL	SPECIFICATION	FIND NO
SE1406-010			UPPER "B" FILL BLOCK	G10		

← NEXT ASSEMBLY

PARTS LIST

NO REPRESENTATION OR WARRANTY, EXPRESSED OR IMPLIED, IS MADE AS TO THE ACCURACY, COMPLETENESS OR USEFULNESS OF THE INFORMATION OR STATEMENTS CONTAINED IN THESE DRAWINGS, OR THAT THE USE OR DISCLOSURE OF ANY INFORMATION, APPARATUS, METHOD OR PROCESS DISCLOSED IN THESE DRAWINGS MAY NOT INFRINGE PRIVATE RIGHTS OF OTHERS. NO LIABILITY IS ASSUMED WITH RESPECT TO THE USE OF, OR FOR DAMAGES RESULTING FROM THE USE OF, ANY INFORMATION, APPARATUS, METHOD OR PROCESS DISCLOSED IN THESE DRAWINGS. DRAWINGS MADE AVAILABLE FOR INFORMATION TO BIDDER ARE NOT TO BE USED FOR OTHER PURPOSES, AND ARE TO BE RETURNED UPON REQUEST OF THE FORWARDING CONTRACTOR.

**P** THIS DRAWING PRODUCED ON PRO-ENGINEER

SCALE 1:1	DES PJ FOGARTY 10-1-04	Oak Ridge National Laboratory managed for the DEPARTMENT OF ENERGY under U.S. GOVERNMENT contract DE-AC05-00OR22725 UT-BATTELLE, LLC, Oak Ridge, Tennessee PROJECT NAME <b>NATIONAL COMPACT STELLARATOR EXPERIMENT</b>
TOLERANCES UNLESS OTHERWISE SPECIFIED	DRW T HARGROVE 10-12-04	
FRACTIONS	CHK M COLE 10-14-04	
XX DECIMALS ±.01	DEPT :	
XXX DECIMALS ±.005	PE D WILLIAMSON 10-14-04	TRC FILL BLOCK UPPER "B"
ANGLES ±0°15'	CR :	
BREAK SHARP EDGES OR MAX FINISH .125 UNLESS OTHERWISE SPECIFIED	PJ :	
	REQ :	
	PPPL DRFT J SIEGEL 10-14-04	VERSION NO. 3±
		PLANT X-10
		BLDG 5700
		FL 3
		SHT 1
		OF 1
		TYPE I
		CLASS U
		RELEASE LEVEL WIP
		SE1406-137
		REV 0