

Modular Coil Analysis Status and Plans

D. Williamson
25 February 2004

Presentation Outline



- Requirements / Design
 - Winding forms
 - Coil windings
- Analysis Approach
 - Geometry, meshing
 - Loads
 - Material properties
 - Results
- Plans for Final Design

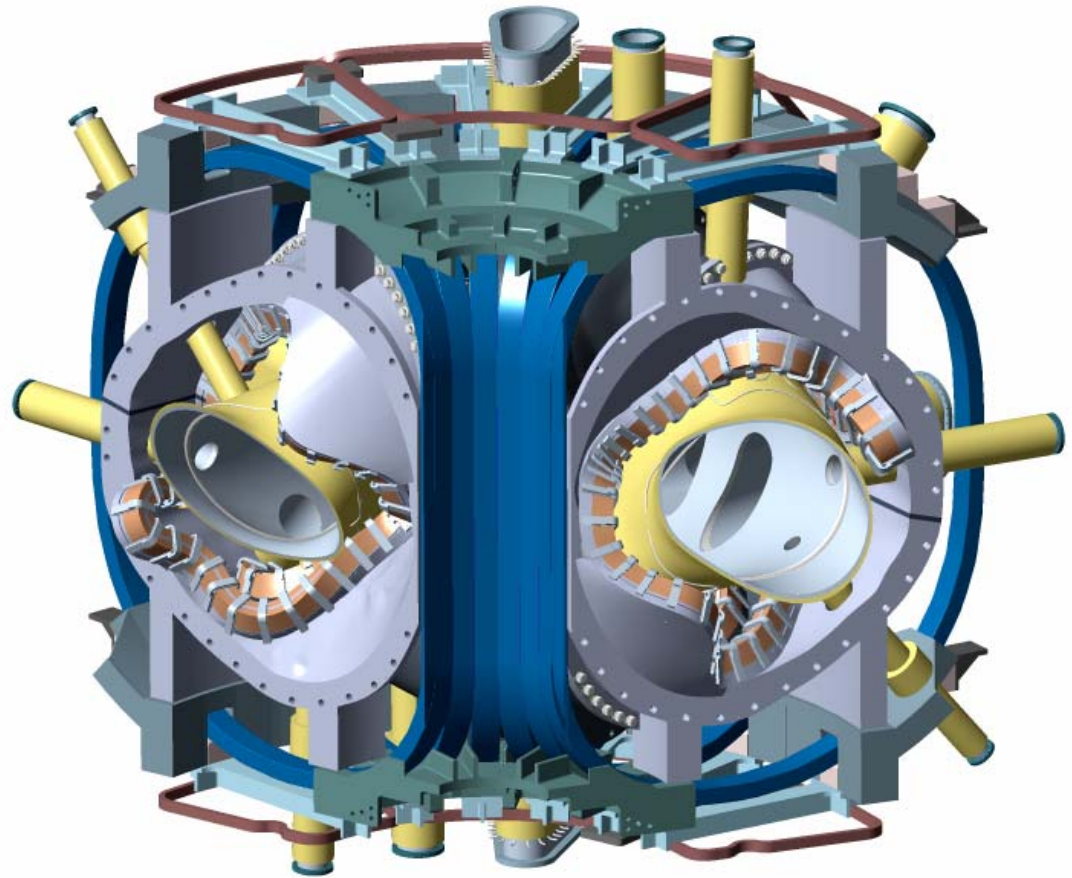

- The winding forms shall provide an accurate means of positioning the conductor during the winding and vacuum-pressure impregnation (VPI) process
 - Machined surfaces within 0.020-in (0.5-mm) of CAD profile
 - Segmented for assembly and to meet electrical requirements
 - Provide access for NBI, ICRH, diagnostics, personnel
 - Support vacuum vessel, interface with PF/TF coil structure
- The coil windings shall provide the basic quasi-axisymmetric field configuration
 - Field up to 2-T for 1-s with 15-min rep rate
 - Winding center accurate to +/- 0.060-in (1.5-mm)
 - Independent control of each coil type for flexibility
 - Feedback for coil protection system
- Design for 150 cool-down cycles, 130,000 pulses over >10 years of operation

Design Description - Structural Shell



- Integral shell composed of 18 modular coil assemblies
- Three field periods, 6 coils per period, 3 coil types
- Total weight = 125,000-lb

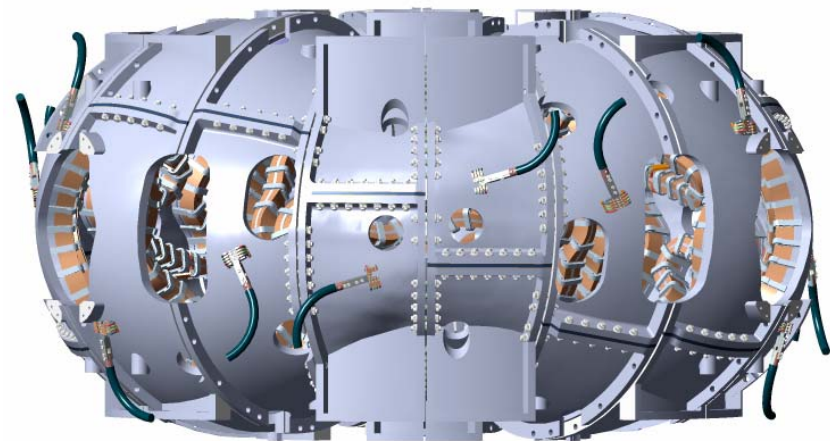
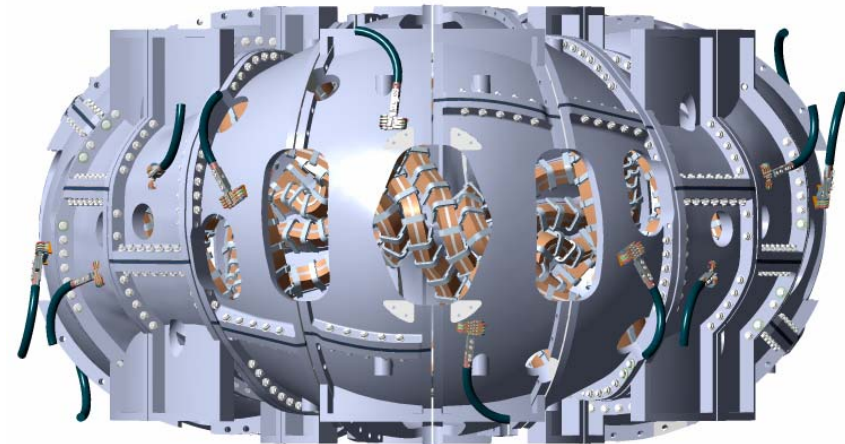
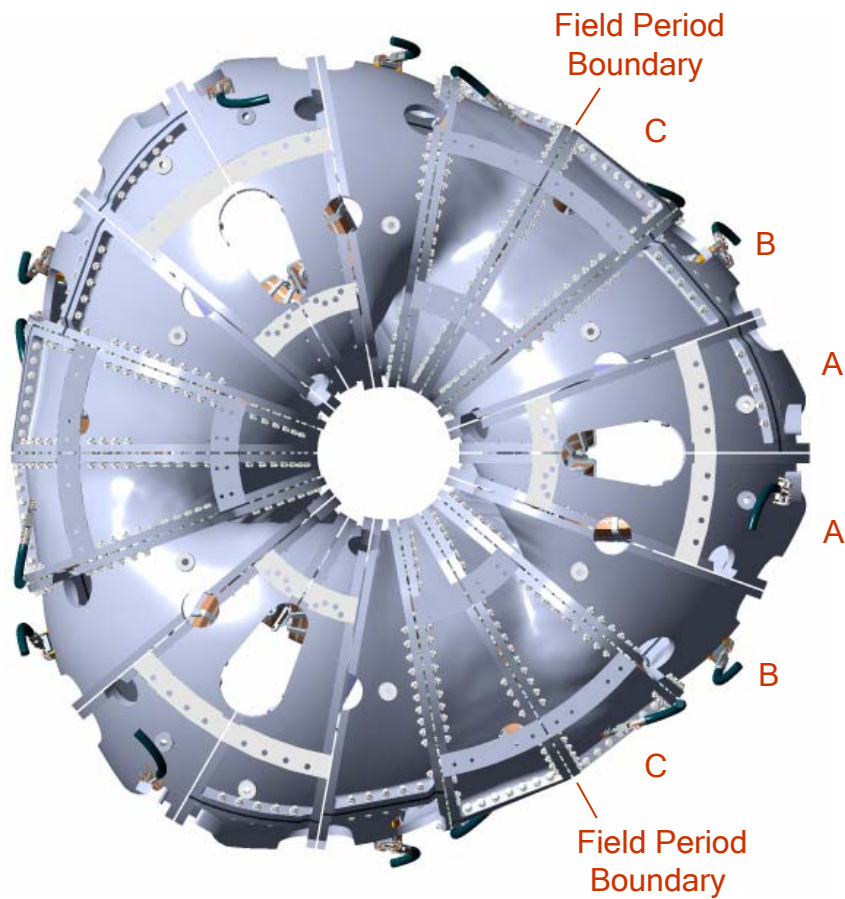

Design Description - Winding Pack

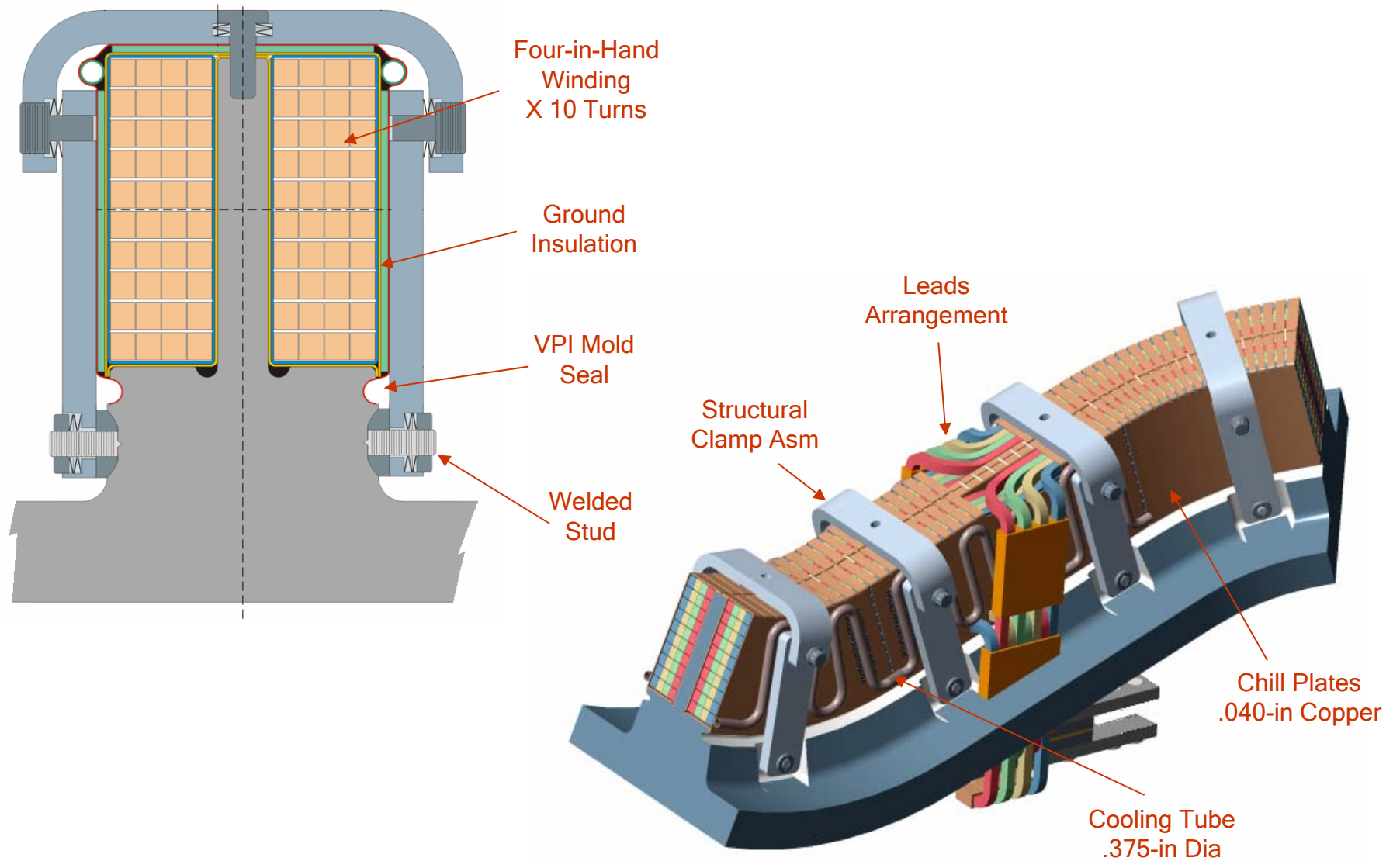

Winding Pack and Shell Design Approach



- Structural shell is designed to support all force acting on the windings
- Coil assembly has been designed for “stiff” or “soft” conductor properties
 - Clamps designed for stiff winding will work for softer conductor
 - Gaps close as winding conforms to shell
 - Winding stress is lower
- Main goal of analysis then is to determine accurate winding deflection so it may be possible to quantify field errors during operation

Analysis Approach



- Preliminary analysis has validated several modular coil design features:
 - Eddy current analysis for electrical segmentation, poloidal break design
 - Transient thermal analysis for coil cooling line configuration
 - Field error analysis to determine required winding form tolerance
- Structural analysis, however, has proved to be complicated due to complex geometry and lack of material property data
- Analysis to-date involves mostly global and some detailed models, with varying degrees of realism

Issue	Approach
Normal EM loads	1) Perform 3D magnetostatic analysis of coil sets incl PF/TF/plasma
	2) Check by independent analysis
Fault Loads	1) Calculate load matrix based on min/zero/max current in each coil circuit
	2) Check worst-case loads by independent analysis
Winding Pack Behavior	1) Evaluate stress in conductor and insulation due to pulse
	2) Check by correlation with tests and simplified modeling
Clamp Behavior	1) Evaluate deflection behavior and stress in detailed clamp model
	2) Check by correlation with tests and simplified modeling
Deflection of Coil Assembly	1) Perform 3D global deflection analysis with detailed shell structure but simplified winding/clamp geometry. Evaluate gravity/EM/thermal/fault load conditions.
	2) Assume fixed winding form, evaluate deflection/stress in winding pack with non-linear contact to structure and more exact clamp behavior.
	3) Check to some level by independent analysis.
Stress in Structure at Interfaces, Openings	1) As part of 3D global analysis, evaluate stress in bolts and at concentrations.
	2) Check by independent local analysis
Seismic Event	1) Part of stellarator core global dynamic analysis.
Error Field Analysis	1) Evaluate postulated fabrication errors and coil deflection under load to determine best position of coils at assembly.
Eddy Currents	1) Perform 3D analysis of assembly with electrical breaks, openings, etc
	2) Check by independent analysis
Heating, Cool-Down between Pulses	1) Perform 2D/3D transient conduction analysis
Vessel Bakeout	1) Perform 2D/3D thermal analysis of cross-section in regions of small gap between vessel and coil
	2) Check by independent analysis

Electromagnetic Loads



- Calculations have been performed using ANSYS and MAGFOR with good agreement
- Max flux density at windings is 4.7-T for 2-T scenario
- At 2-T, large centering force up to 317-kip (1.4-MN) per coil
- Max vertical load up to 122-kip (0.5-MN) per coil

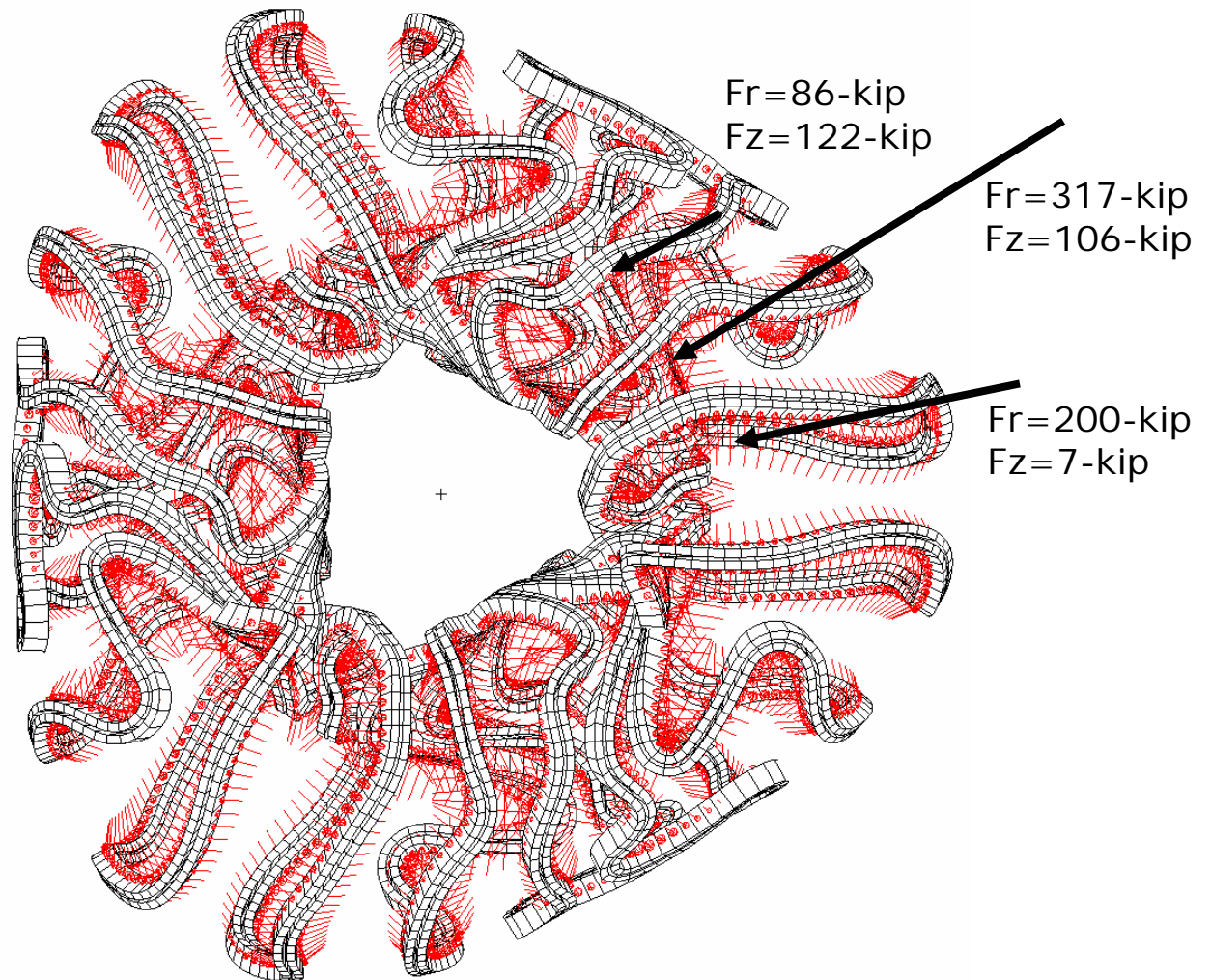

Global Deflection / Stress Model



- Single field-period (120-deg) model with rotational symmetry
- Tee and shell modeled separately, joined by constraint equations
- Wings modeled by increasing thickness of tee outside of sector
- Winding pack attached to shell, EM loads for 2-T scenario

Cases studied:

- With/without wing attached to adjacent shell
- Coil properties at 5%, 50% of copper

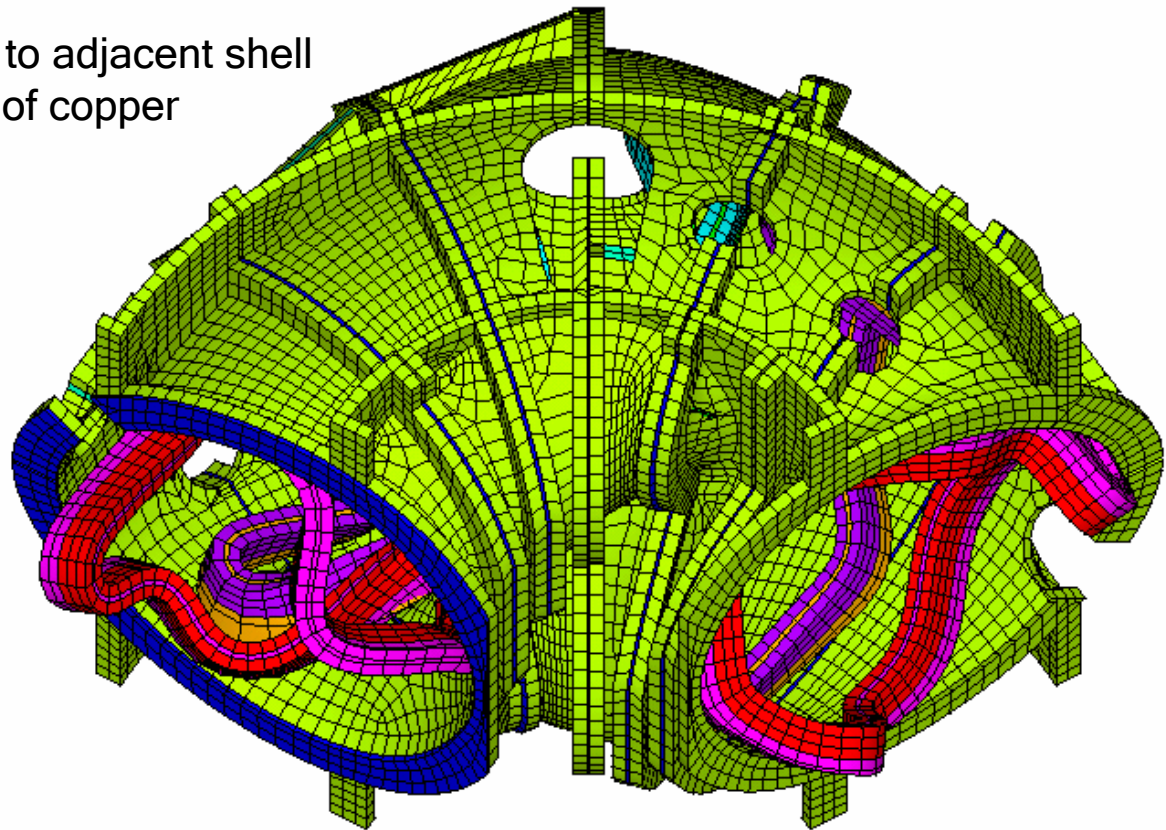

Global Model Results



- Assumptions are wing attached, soft winding pack
- Max displacement is 0.97-mm (0.038-in) in outboard region
- Max Von Mises stress is 181-MPa (26.2-ksi) around opening

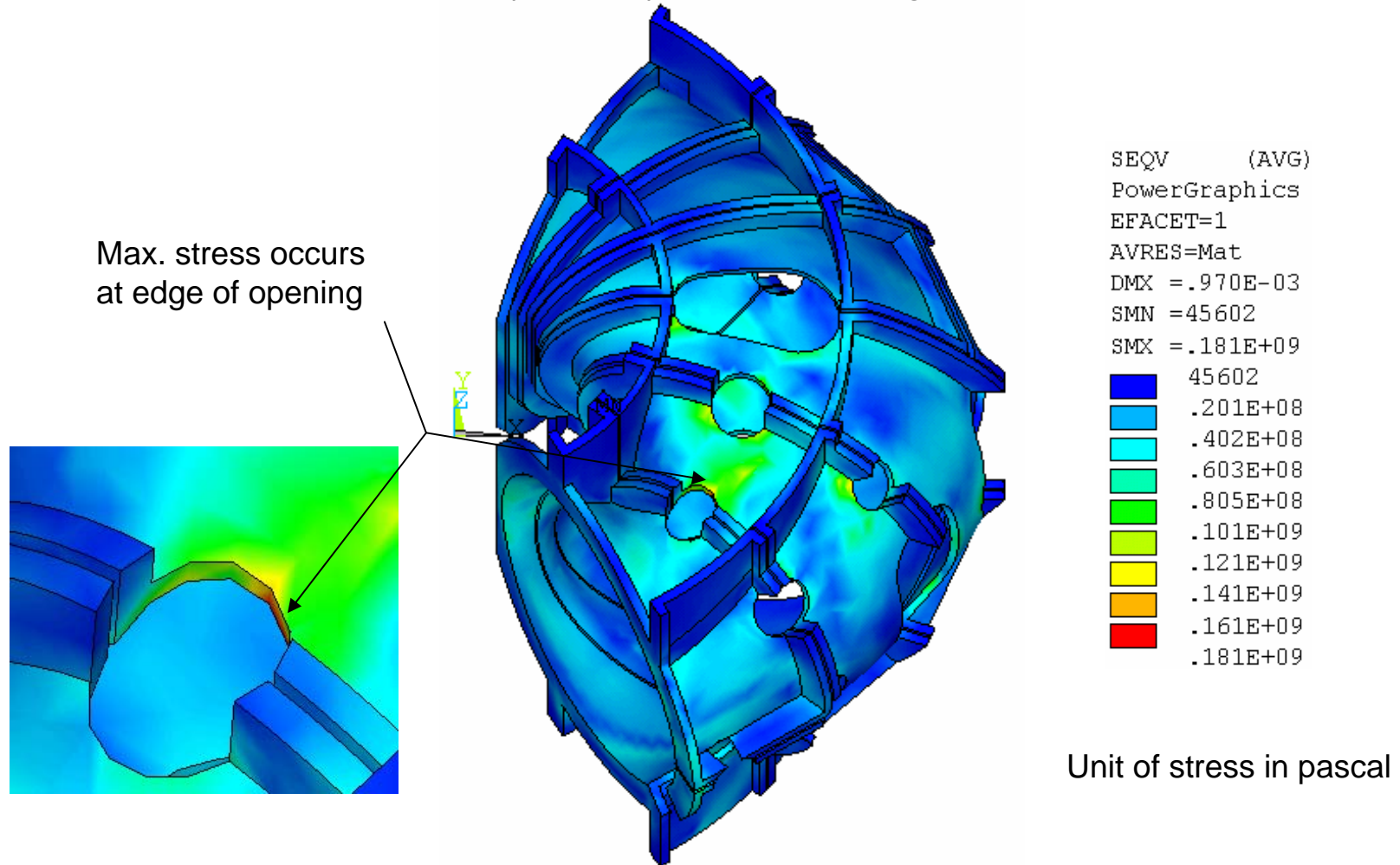

Global Model Improvements



- Tet meshing using ProE to ANSYS Workbench Environment has been investigated
- Issues are contact surfaces, symmetry boundary conditions, higher mesh density
- Initial results comparable to PDR analysis model

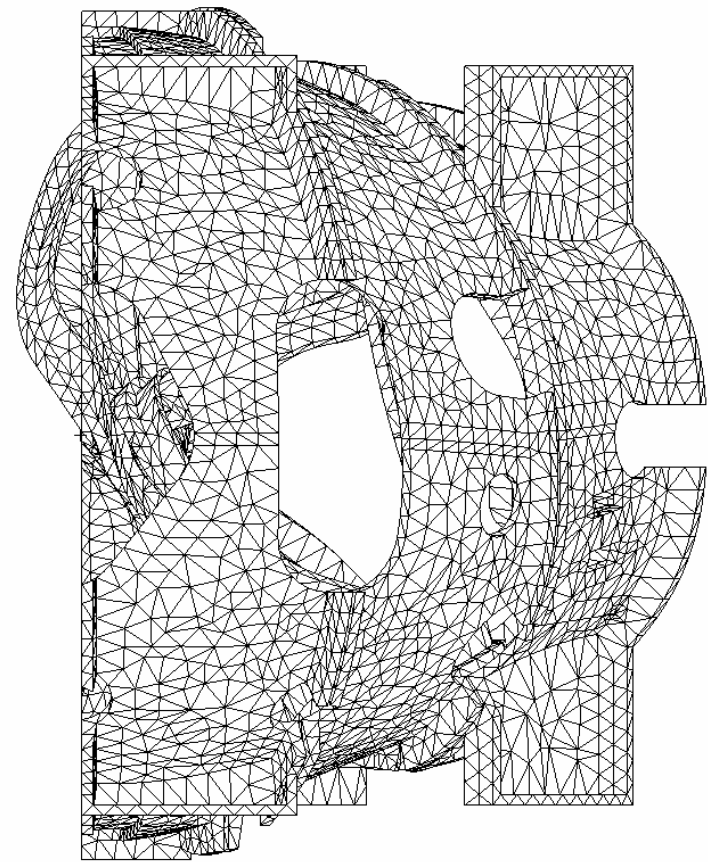
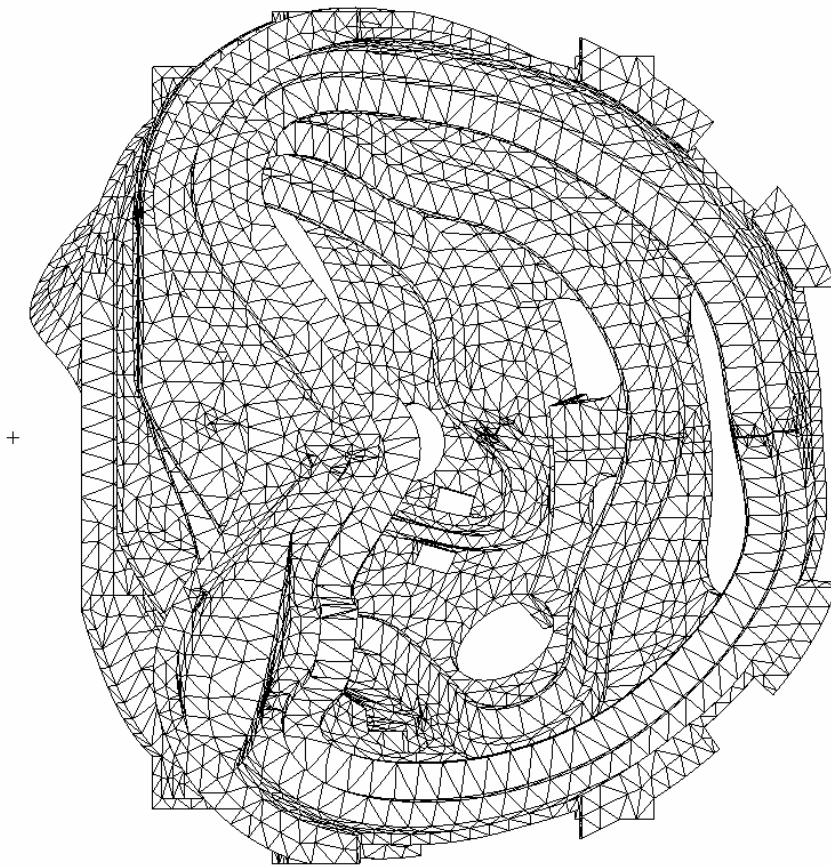

Shell Interfaces, Bolting



- Shell interface design has changed since PDR, needs to be included in global model
- Alternative is to develop a local model of the flange/wing areas with enforced displacements

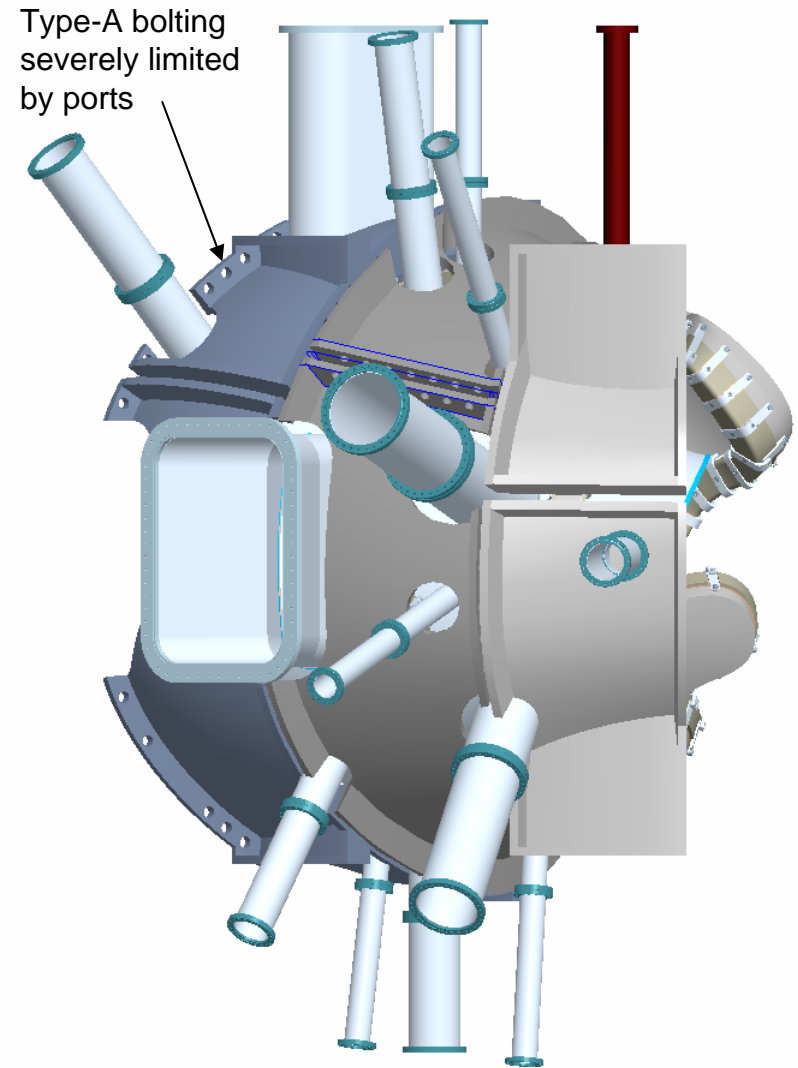
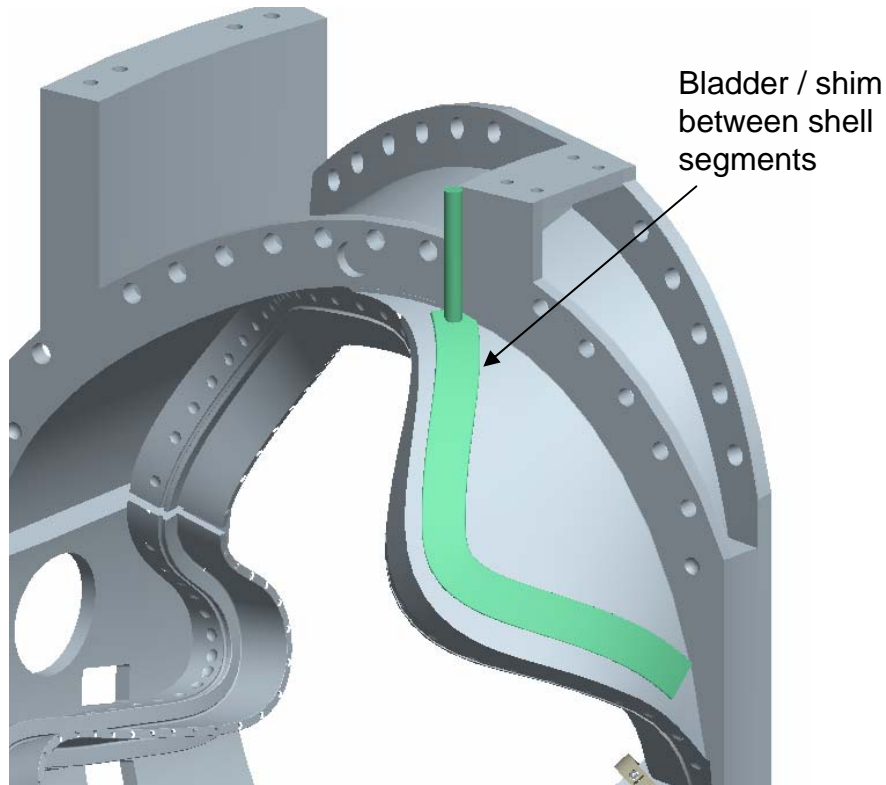

Winding Pack Behavior



Thermal assumptions:

- Relative strain between winding pack and winding form due to cure shrinkage is 0.04%, and due to cool-down from RT is 0.04%
- Winding moves away from coil form and gaps may open in localized regions
- Shrinkage provides room for coil expansion during pulse, 0.04% relative to winding form

Mechanical assumptions:

- Conductor modulus is 14,400-ksi in tension and 5,300-ksi in compression

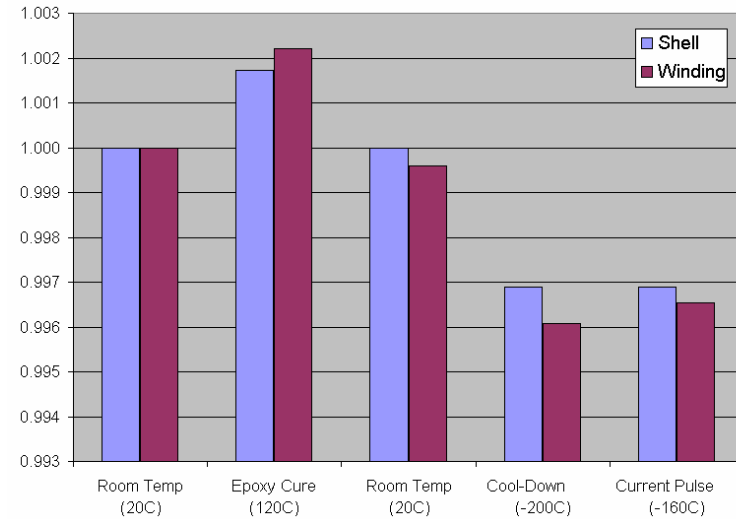

Clamp Behavior

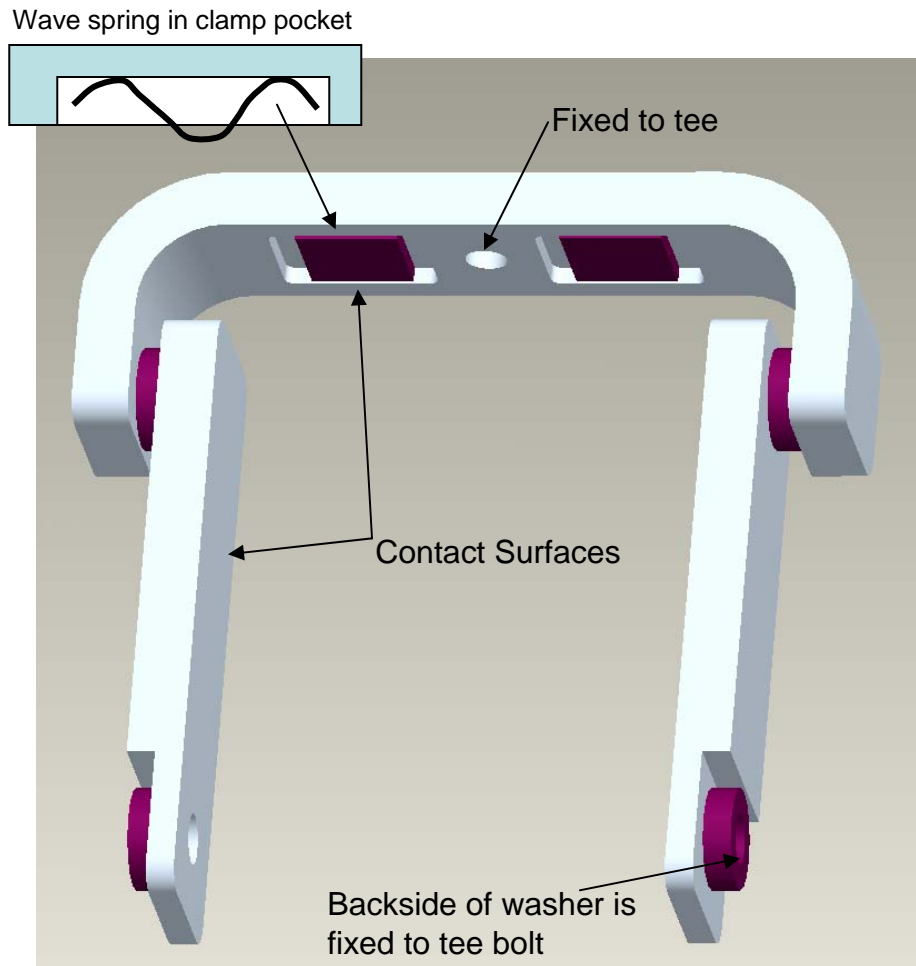

Contact Surfaces are used between the clamp and the winding.

-Modulus of washers is tailored to represent the spring constant of the belleville washers. Example: $k = 26,000 \text{ lb/in}$, $A_{\text{washer}} = 0.81 \text{ in}^2$, $\text{Depth}_{\text{washer}} = 0.15 \text{ in}$. Therefore: $E = k \cdot \text{depth} / A = 4814 \text{ psi}$

- The cte of the washer is used to impose a preload on the clamp and winding. Assume 0.1 in/in stain
Therefore: $\text{cte} = 0.1 / -72 F = -0.00138 / F$
and preload for "hard" springs is 2600 lbs, and 1000 for "soft" springs

- All washers have the same spring constant but have different modulus values.

-The clamp is fixed to the tee by a stud at the top of the clamp and a representative bolt head on the lower end.

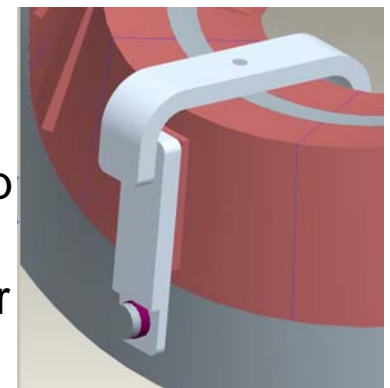

Winding Pack and Clamps



- Non-linear model of windings on fixed tee has been developed using MECHANICA (p-elements)
- Contact surfaces between winding and tee allow winding to separate from and slide along tee
- Pseudo-clamps (48) are represented by low modulus material with directional restraints
- Properties of block simulate clamp spring force (26,000-lb/in) and preload (~1000-lb)
- Results show max displacement is 2-mm (0.080-in), max stress ~16-ksi due to cool-down plus EM load

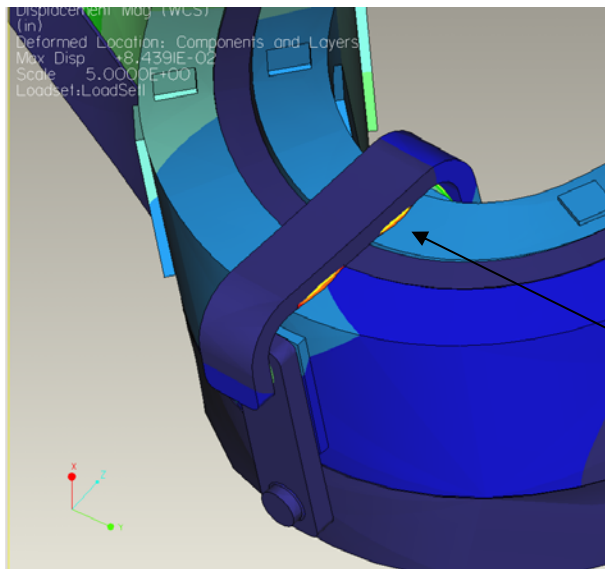
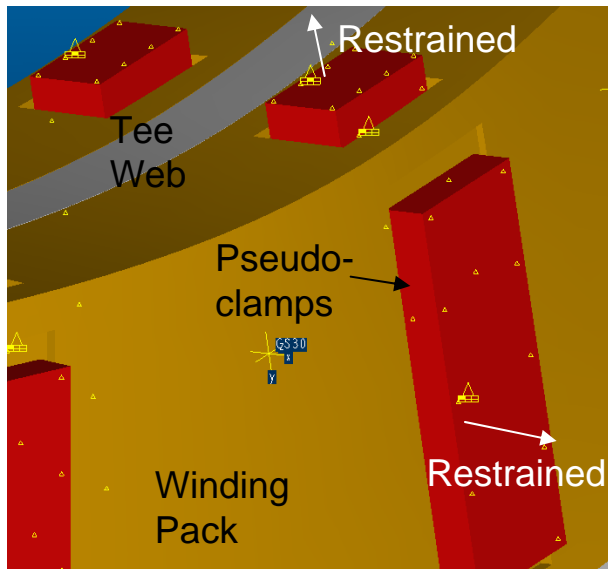
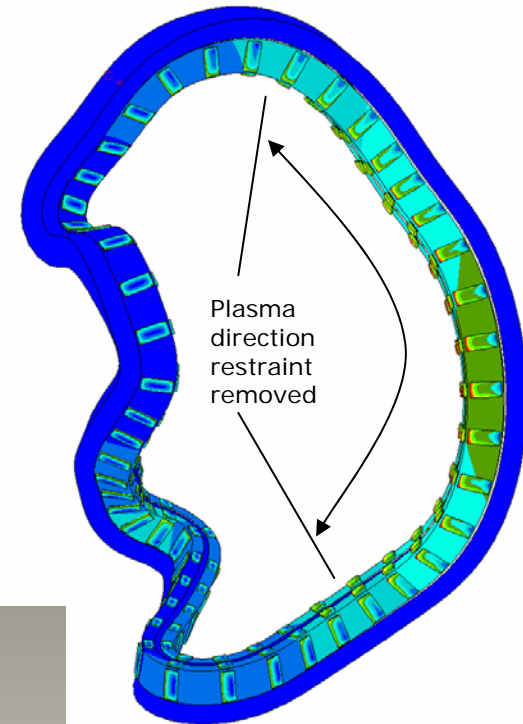

Detailed clamp model has been added, others are pseudo-clamps

Thermal Analysis



- Transient conduction/convection model has been updated for four-in-hand winding
- Updated analysis of LN2 flow, pressure drop to be done
- Evaluation of localized coil heating during vessel bakeout to be done

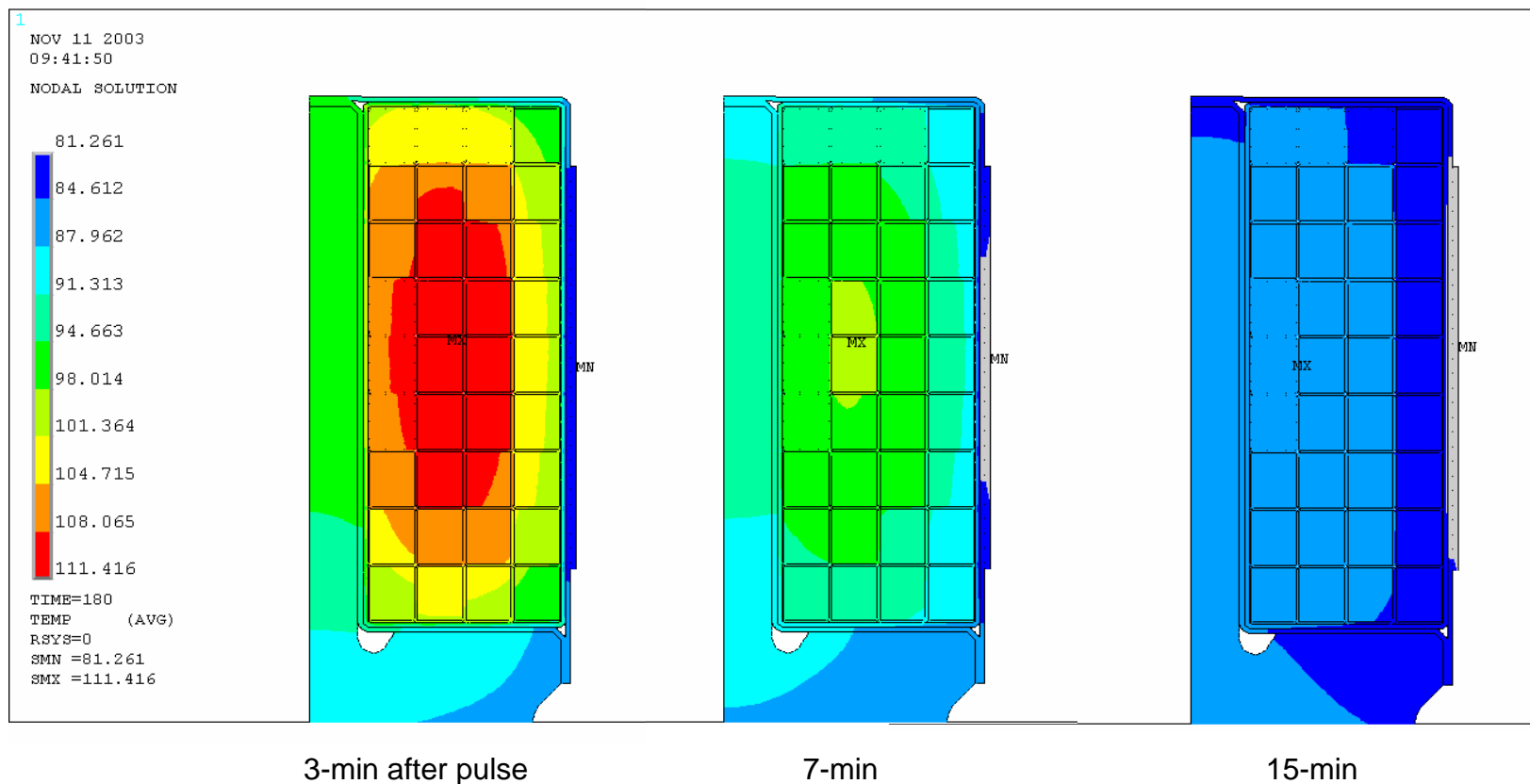

Eddy Currents, Field Error Analysis



- Eddy current analysis shows longest time constant is <20-ms with one poloidal break and all but three of the toroidal joints isolated. Analysis will be updated to reflect addition of vessel ports and other cutouts.
- Field error analysis is being developed for postulated fabrication errors in coil geometry. It is planned to adjust the final assembly position of each coil in order to minimize magnetic islands. A procedure is also being developed to evaluate and compensate for coil deflections due to electromagnetic and thermal loads.

Seismic Analysis

NCSX

- Modular coils are supported by TF/PF structure through machine columns
- Weight of stellarator core is ~ 100 -tons



Final Design Review Plans



Issue	Approach	Resources
Normal EM loads	1) Perform 3D magnetostatic analysis of coil sets incl PF/TF/plasma	Fan - ANSYS
	2) Check by independent analysis	Williamson - MAGFOR
Fault Loads	1) Calculate load matrix based on min/zero/max current in each coil circuit	Williamson - MAGFOR
	2) Check worst-case loads by independent analysis	Fan - ANSYS
Winding Pack Behavior	1) Evaluate stress in conductor and insulation due to pulse	Myatt - ANSYS
	2) Check by correlation with tests and simplified modeling	
Clamp Behavior	1) Evaluate deflection behavior and stress in detailed clamp model	Freudenberg - MECHANICA
	2) Check by correlation with tests and simplified modeling	
Deflection of Coil Assembly	1) Perform 3D global deflection analysis with detailed shell structure but simplified winding/clamp geometry. Evaluate gravity/EM/thermal/fault load conditions.	Fan - ANSYS
	2) Assume fixed winding form, evaluate deflection/stress in winding pack with non-linear contact to structure and more exact clamp behavior.	Freudenberg - MECHANICA
	3) Check to some level by independent analysis.	Myatt - ANSYS
Stress in Structure at Interfaces, Openings	1) As part of 3D global analysis, evaluate stress in bolts and at concentrations.	Fan - ANSYS
	2) Check by independent local analysis	Jun - ANSYS
Seismic Event	1) Part of stellarator core global dynamic analysis.	Titus - ANSYS
Error Field Analysis	1) Evaluate postulated fabrication errors and coil deflection under load to determine best position of coils at assembly.	Brooks, Strickler
Eddy Currents	1) Perform 3D analysis of assembly with electrical breaks, openings, etc	Brooks - SPARK
	2) Check by independent analysis	Strickler, Williamson - EDDYCUFF
Heating, Cool-Down between Pulses	1) Perform 2D/3D transient conduction analysis	Fan - ANSYS
Thermo-hydraulic Analysis	1) Determine operating temperature distribution, flow, pressure drop	TBD
Vessel Bakeout	1) Perform 2D/3D thermal analysis of cross-section in regions of small gap between vessel and coil	Freudenberg - ANSYS
	2) Check by independent analysis	