

- NOTES:
1. INTERPRET DIMENSIONS AND TOLERANCES PER ANSI Y14.5M.
 2. DIMENSION ARE IN INCHES.
 3. FABRICATION, INSPECTION, AND TESTING SHALL BE PERFORMED IN ACCORDANCE WITH SPECIFICATION NCSX-CSPEC-121-02 AND STATEMENT OF WORK NCSX-SOW-121-03.
 4. DIMENSIONS APPLY AT NEXT ASSEMBLY, SE121-102.

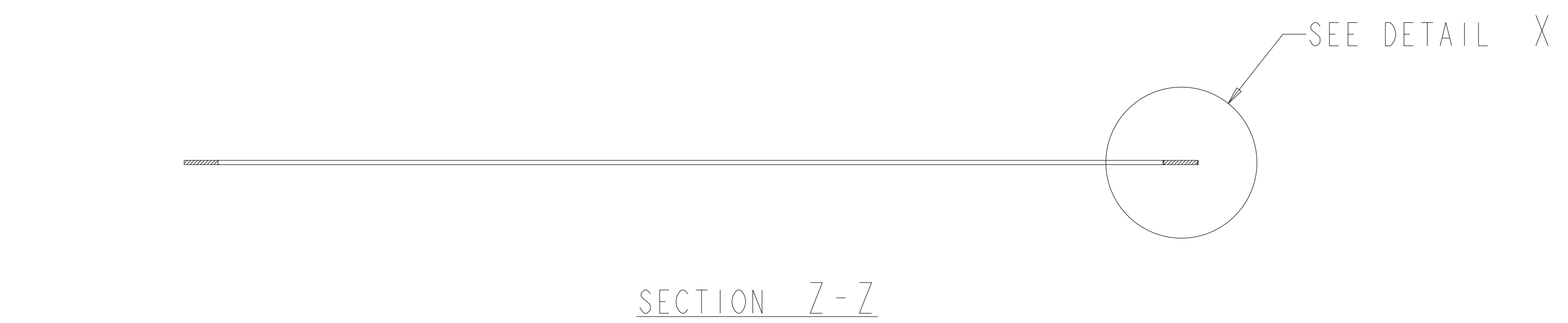

SECTION Z-Z

SCALE 0.25

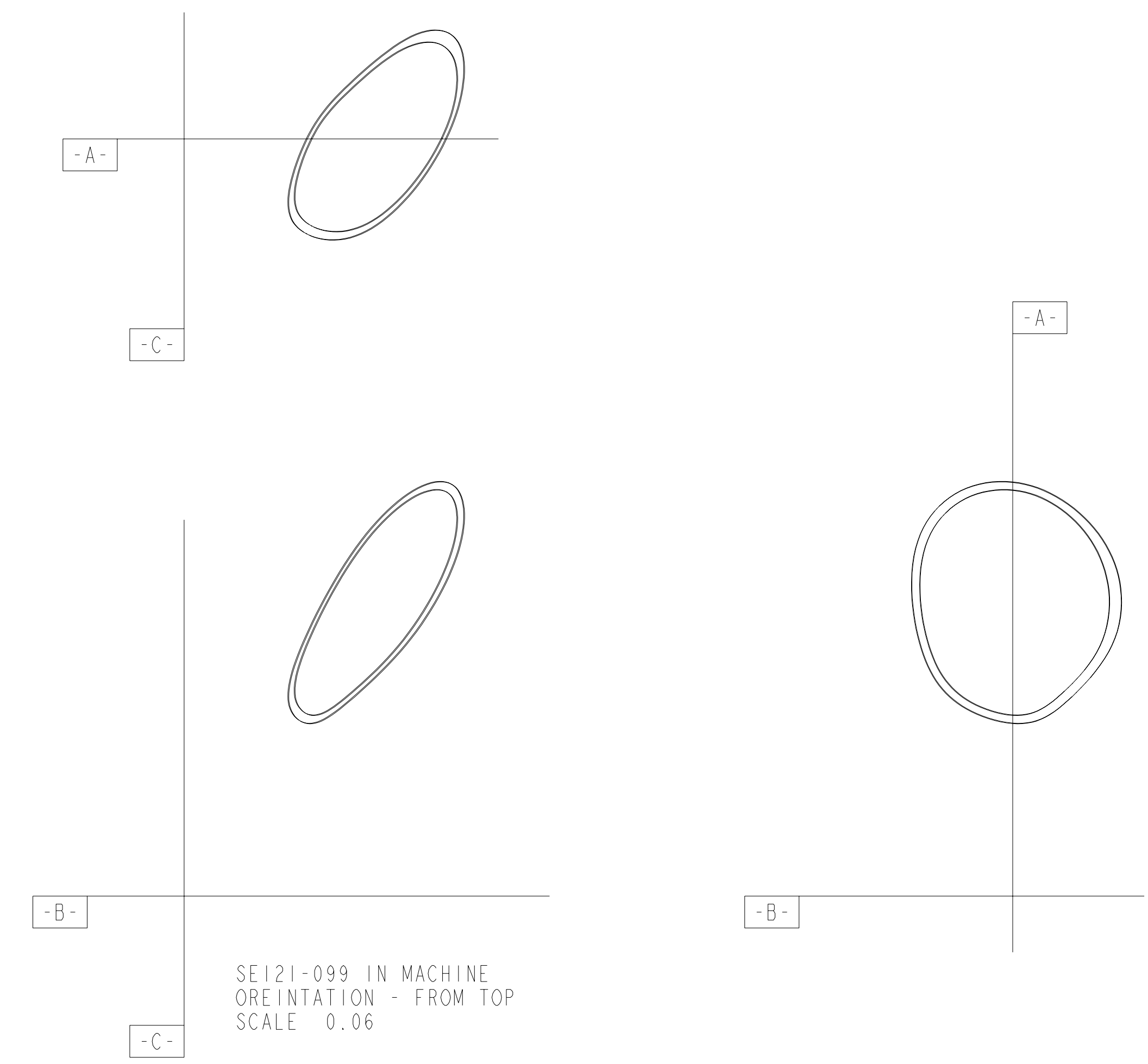
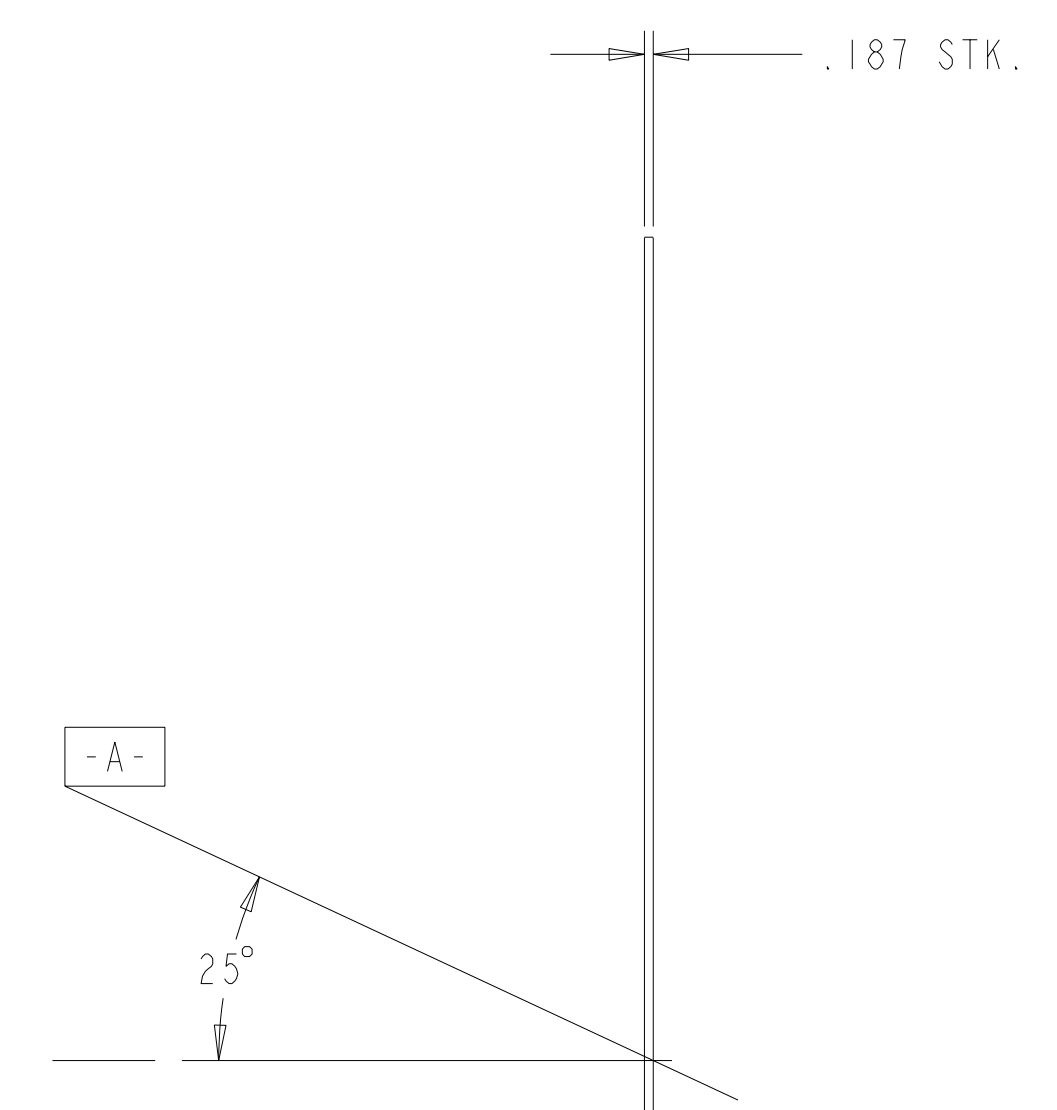
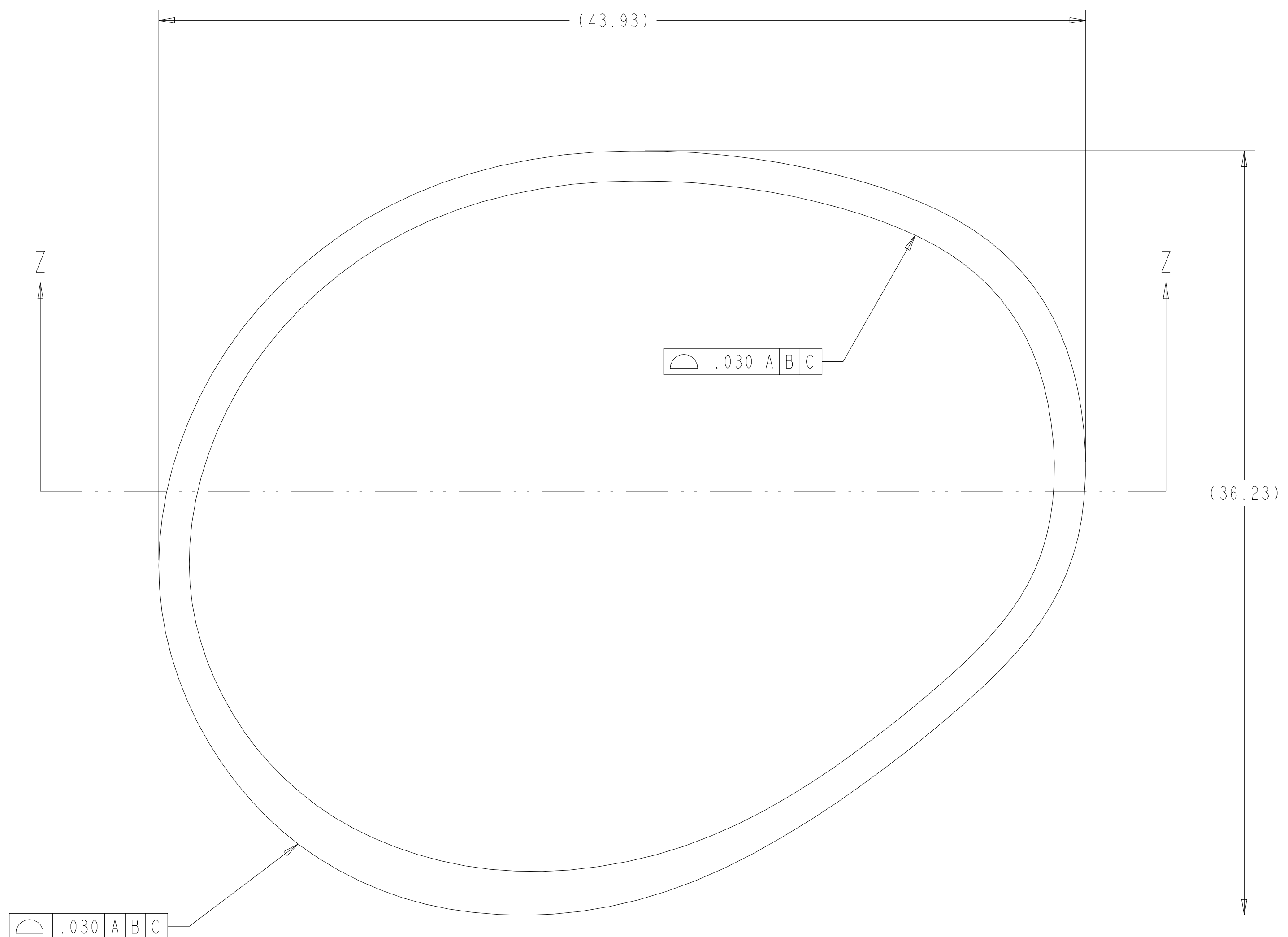
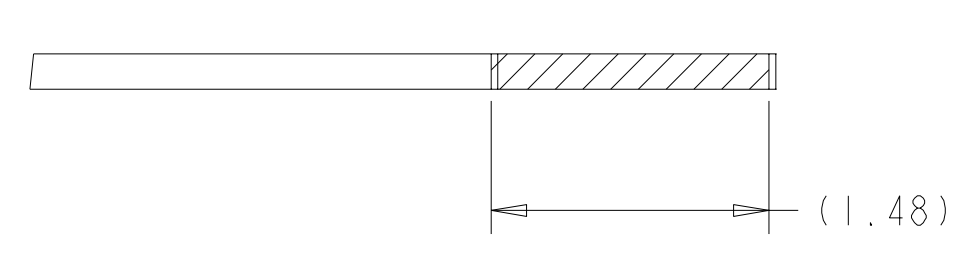

DETAIL X
SCALE 1.00

**RELEASED FOR
FABRICATION / INSTALLATION**
PPPL Drafting:

AR	-1	VACUUM VESSEL BLANK OFF SEAL DETAIL	UNS-N06625	1
CAGE CODE	PART OR IDENTIFYING NO	NOMENCLATURE OR DESCRIPTION	MATERIAL	FIND NO
SE121-102	NEXT ASSEMBLY			
PARTS LIST				

NO REPRESENTATION OR WARRANTY, EXPRESSED OR IMPLIED, IS MADE AS TO THE ACCURACY, COMPLETENESS OR USEFULNESS OF THE INFORMATION OR STATEMENTS CONTAINED IN THESE DRAWINGS, OR THAT THE USE OR DISCLOSURE OF ANY INFORMATION, APPARATUS, METHOD OR PROCESS DISCLOSED IN THESE DRAWINGS MAY NOT INFRINGE PRIVATE RIGHTS OF OTHERS. NO LIABILITY IS ASSUMED WITH RESPECT TO THE USE OF, OR FOR DAMAGES RESULTING FROM THE USE OF, ANY INFORMATION, APPARATUS, METHOD OR PROCESS DISCLOSED IN THESE DRAWINGS. DRAWINGS MADE AVAILABLE FOR INFORMATION TO BIDDERS ARE NOT TO BE USED FOR OTHER PURPOSES, AND ARE TO BE RETURNED UPON REQUEST OF THE FORWARDING CONTRACTOR.

P THIS DRAWING PRODUCED ON PRO-ENGINEER

REV	DESCRIPTION	BY	DATE	CHK	DEPT	DATE	PE	REQ	DATE	ORNL	DOE	DATE																																																															
REVISION APPROVAL																																																																											
<table border="0" style="width: 100%;"> <tr> <td style="width: 30%;">SCALE AS NOTED</td> <td>DES: P. GORANSON</td> <td>8MAY04</td> </tr> <tr> <td>TOLERANCES UNLESS OTHERWISE SPECIFIED</td> <td>DRW: G. FORTIER</td> <td>8MAY04</td> </tr> <tr> <td>FRACTIONS</td> <td>CHK: M. COLE</td> <td>6/04</td> </tr> <tr> <td>XX DECIMALS ±.01</td> <td>SECT:</td> <td></td> </tr> <tr> <td>XXX DECIMALS ±.005</td> <td>DEPT:</td> <td></td> </tr> <tr> <td>ANGLES ±0°15'</td> <td>PE:</td> <td></td> </tr> <tr> <td>BREAK SHARP EDGES .06 MAX</td> <td>CR:</td> <td></td> </tr> <tr> <td>FINISH .125 UNLESS OTHERWISE SPECIFIED</td> <td>PJ:</td> <td></td> </tr> <tr> <td></td> <td>REQ:</td> <td></td> </tr> <tr> <td></td> <td>PPPL DRFT: J. SIEGEL</td> <td>6/04</td> </tr> <tr> <td></td> <td>VERSION NO.:</td> <td>21</td> </tr> <tr> <td></td> <td>PLANT:</td> <td>X-10</td> </tr> <tr> <td></td> <td>BLDG:</td> <td>5700</td> </tr> <tr> <td></td> <td>FL:</td> <td>3</td> </tr> <tr> <td></td> <td>SHT OF:</td> <td>1</td> </tr> <tr> <td></td> <td>TYPE:</td> <td>ID</td> </tr> <tr> <td></td> <td>CLASS:</td> <td>U</td> </tr> <tr> <td></td> <td>RELEASE LEVEL:</td> <td>Fabrication</td> </tr> <tr> <td></td> <td>PROJECT NAME:</td> <td>NATIONAL COMPACT STELLARATOR EXPERIMENT</td> </tr> <tr> <td></td> <td>PROJECT NO.:</td> <td>SE121-099</td> </tr> <tr> <td></td> <td>REV:</td> <td>0</td> </tr> </table>													SCALE AS NOTED	DES: P. GORANSON	8MAY04	TOLERANCES UNLESS OTHERWISE SPECIFIED	DRW: G. FORTIER	8MAY04	FRACTIONS	CHK: M. COLE	6/04	XX DECIMALS ±.01	SECT:		XXX DECIMALS ±.005	DEPT:		ANGLES ±0°15'	PE:		BREAK SHARP EDGES .06 MAX	CR:		FINISH .125 UNLESS OTHERWISE SPECIFIED	PJ:			REQ:			PPPL DRFT: J. SIEGEL	6/04		VERSION NO.:	21		PLANT:	X-10		BLDG:	5700		FL:	3		SHT OF:	1		TYPE:	ID		CLASS:	U		RELEASE LEVEL:	Fabrication		PROJECT NAME:	NATIONAL COMPACT STELLARATOR EXPERIMENT		PROJECT NO.:	SE121-099		REV:	0
SCALE AS NOTED	DES: P. GORANSON	8MAY04																																																																									
TOLERANCES UNLESS OTHERWISE SPECIFIED	DRW: G. FORTIER	8MAY04																																																																									
FRACTIONS	CHK: M. COLE	6/04																																																																									
XX DECIMALS ±.01	SECT:																																																																										
XXX DECIMALS ±.005	DEPT:																																																																										
ANGLES ±0°15'	PE:																																																																										
BREAK SHARP EDGES .06 MAX	CR:																																																																										
FINISH .125 UNLESS OTHERWISE SPECIFIED	PJ:																																																																										
	REQ:																																																																										
	PPPL DRFT: J. SIEGEL	6/04																																																																									
	VERSION NO.:	21																																																																									
	PLANT:	X-10																																																																									
	BLDG:	5700																																																																									
	FL:	3																																																																									
	SHT OF:	1																																																																									
	TYPE:	ID																																																																									
	CLASS:	U																																																																									
	RELEASE LEVEL:	Fabrication																																																																									
	PROJECT NAME:	NATIONAL COMPACT STELLARATOR EXPERIMENT																																																																									
	PROJECT NO.:	SE121-099																																																																									
	REV:	0																																																																									