

NO.	REVISION	BY	CH	SUP	APPROVED	DATE

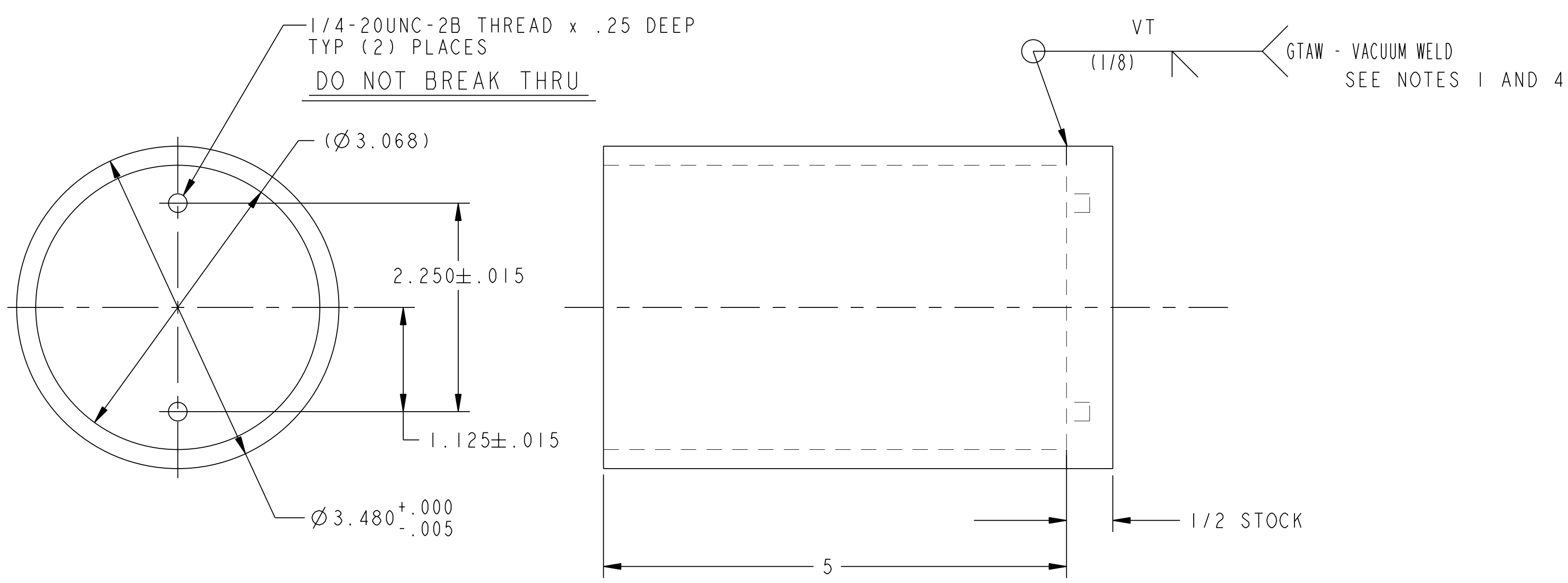

1 SXR MOUNTING CUP
(15) REQ'D

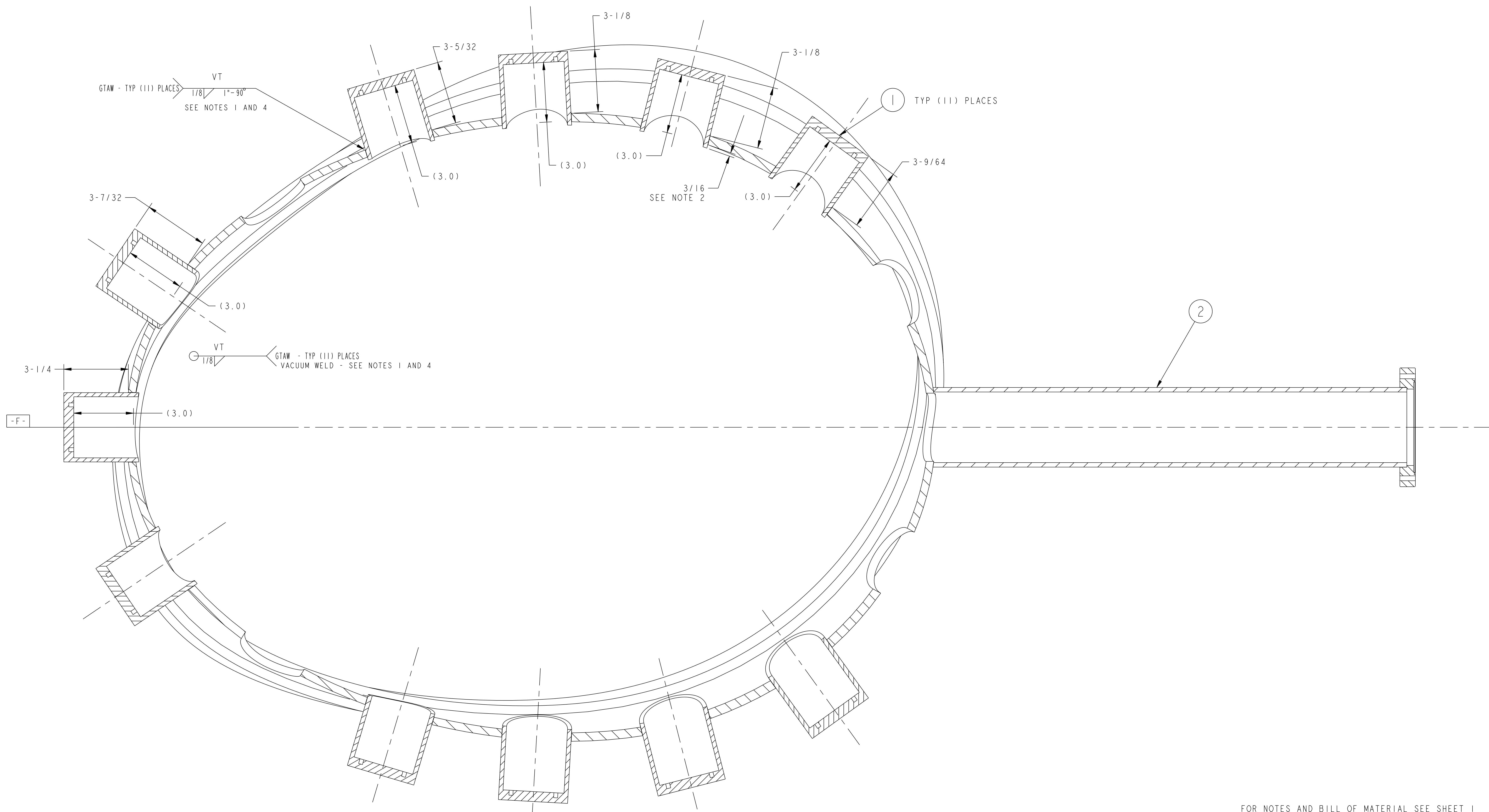
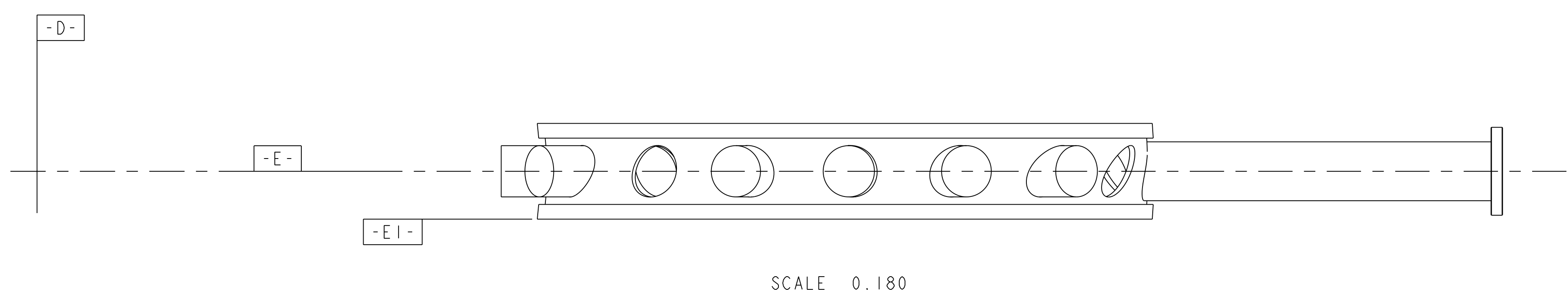

SECTION A-A

DIMENSIONS SHOWN ARE SYMMETRICAL ABOUT HORIZONTAL CENTERLINE

FOR NOTES AND BILL OF MATERIAL SEE SHEET 1

COMPUTER GENERATED DRAWING MANUAL CHANGES NOT PERMITTED Pro E	CENTRAL FILES:	PRINCETON PLASMA PHYSICS LABORATORY PRINCETON UNIVERSITY	
	UNLESS OTHERWISE SPECIFIED	NATIONAL COMPACT STELLARATOR EXPERIMENT	
DO NOT VERIFY INFORMATION BY SCALING DRAWING	DIMENSIONS ARE IN INCHES MACHINE SURFACES	MHD DIAGNOSTICS SOFT X-RAY DIAGNOSTIC SXR ARRAY MOUNTING CUP WELDMENT	
NEXT ASSEMBLY	TOLERANCES NON-CUMULATIVE DECIMAL-INCH FRACTIONS .XX ±.000 .XXX ±.005 ANGULAR ±.0°-15°	DSN: L. MORRIS	DRAWING NO: SE340-001
WEIGHT +5472.2 lbs		ENGR: T. BROWN	SHEET 2 OF 2
MODEL NAME SE340-001		SUPV:	REV 0
RELEASE LEVEL: WIP DWG VERSION NO: 9			

NCSX-SE340-001