

ISOMETRIC VIEW

DATUM "A" = PLANE THRU "XY"
 DATUM "B" = PLANE THRU "XZ"
 DATUM "C" = PLANE THRU "YZ"

Rev 2-e: ECN-5021 (RFD-12-017) approved alternate methods for welding the port extensions to the VVSA (See ECN-5021 for details). - Only applicable to VVSA #3 - VVSA #1 and #2 covered by NCR 19464.

Rev 2-a: ECN-4972 (RFD-12-002R1) approved substitution of Schedule 10 for Schedule 40 piping - Applicable to All 3 VVSAs.

Rev 2-b: ECN-5113 (RFD-12-009) authorized leaving holes "as is", but utilizing MDC bolt hardware kit 190045 - Applicable to All 3 VVSAs.

Rev 2-c: ECN-5115 (RFD-12-016) approved modifying weld to fillet weldsto the opposite side of the groove weld and to relax the flatness requirement to 0.050" if opposing side fillets applied - Applicable to All 3 VVSAs.

Rev 2-d: ECN-5082 (RFD-12-014) eliminated weld relief originally requested by MTM since they elected to pursue other means of leak checking. Grooves no longer required. - Applicable to All 3 VVSAs.

QTY	QTY	QTY	QTY	QTY	QTY	QTY	QTY
34	-57	SILVER PLATED, 12-POINT BOLTS, .50-20UNF, 2.00 LG	INCO 718	ASTM A1014	57		
218	-56	WASHER, Ø0.531 ID X Ø1.062 OD X .095 THICK	A286	ANSI 18.22.1	56		
184	-55	NUT, 0.50 X 20UNF	GRADE 8	ASTM A194	55		
2	SE121-095	VACUUM VESSEL SEAL DETAIL			54		
1	-53	O-RING, METAL, HELICOFLEX TYPE HNVT	HELICOFLEX PO BOX 9889 COLUMBIA, SC 29209 PHONE # 1-800-233-1722		53		
1	-52	O-RING, METAL, HELICOFLEX TYPE HNVT			52		
2	-51	CLEVIS BOSS "D"	UNS N06625		51		
2	-50	CLEVIS BOSS "C"	UNS N06625		50		
2	-49	CLEVIS BOSS "B"	UNS N06625		49		
2	-48	CLEVIS BOSS "A"	UNS N06625		48		
40	-47	BUTTON HD CAP SCREW #8-32UNC X .25 LG	300 SERIES SST		47		
2	-46	O-RING, .211 OD, 95.51 LG +0.0/-0.25	VITON		46		
2	-45	O-RING, .211 OD, 90.93 LG +0.0/-0.25	VITON		45		
2	-44	O-RING, .211 OD, 117.82 LG +0.0/-0.25	VITON		44		
2	-43	O-RING, .211 OD, 113.23 LG +0.0/-0.25	VITON		43		
2	-42	O-RING, .211 OD, 63.12 LG +0.0/-0.25	VITON		42		
2	-41	O-RING, .211 OD, 53.53 LG +0.0/-0.25	VITON		41		

QTY	QTY	QTY	QTY	QTY	QTY	QTY	QTY
1	191094	GASKET, COPPER 10.00 ID, PKG 10 REF 12 FLG					40
1	191019	GASKET, COPPER 8.01 ID, PKG 10 REF 10 FLG					39
1	191017	GASKET, COPPER 6.01 ID, PKG 10 REF 8.00 FLG					38
1	191013	GASKET, COPPER 4.01 ID, PKG 10 REF 6.00 FLG					37
1	191011	GASKET, COPPER 3.01 ID, PKG 10 REF 4.63 FLG					36
10	190059	BOLT SET 8.00 OD & 10.00 OD FLG 12PT BOLT, SILVER PLTG, PKG 25					35
12	190058	BOLT SET 4.63 OD & 6.00 OD FLG 12PT BOLT, SILVER PLTG, PKG 25					34
4	190165	HEX HD, .312-24UNC, 2.00 LG PKG 36 WITH NUTS & FLAT WASHERS					33
184	-32	SILVER PLATED, 12-POINT BOLTS, .50-20UNF, 3.5 LG	GRADE 660	ASTM A 453			32
2	FA10000133	REDUCING NIPPLE 10.00 TO 1.33					31
4	FA08000133	REDUCING NIPPLE 8.00 TO 1.33					30
10	FA06000133	REDUCING NIPPLE 6.00 TO 1.33					29
2	FA04620133	REDUCING NIPPLE 4.63 TO 1.33					28
4	130093	CONFLAT, 12.00 OD, TAPPED					26
2	130033	CONFLAT, 10.00 OD, TAPPED					25
4	130031	CONFLAT, 8.00 OD, TAPPED					24
10	130026	CONFLAT, 6.00 OD, TAPPED					23
2	130022	CONFLAT, 4.63 OD TAPPED					22
2	SE121-013	VACUUM VESSEL FLANGE DETAIL			21		
2	-20	ELLIPTICAL HD, 18.00 OD X .375 WALL	BRIGHTON TRU-EDGE HEADS 4955 SPRING GROVE AVE CINCINNATI, OHIO 45232 PHONE # 800 543-1644				20
AR	-19	TUBE, 10.00 X .250 WALL	UNS 06625				19
AR	-18	TUBE, 8.00 X .188 WALL	UNS 06625				18
AR	-17	TUBE, 6.00 X .188 WALL	UNS 06625				17
AR	-16	PIPE, 2.5 SCH 40	UNS 06625				16
AR	-15	PIPE, 3.5 SCH 40	UNS 06625				15
AR	-14	PLATE, .500 THK	UNS 06625				14
AR	-13	PLATE, .375 THK	UNS 06625				13
4	SE122-112	VACUUM VESSEL 12 IN COVER TEST FLANGE DETAIL			12		
2	SE121-102	VACUUM VESSEL BLANK OFF COVER SEAL WELDMENT			11		
1	SE122-172	VACUUM VESSEL NB PORT COVER TEST FLANGE DETAIL			10		
1	SE122-173	VACUUM VESSEL PORT NB SEAL RETAINER DETAIL			9		
1	SE122-072	VACUUM VESSEL PORT NB FLANGE DETAIL			8		
2	SE122-149	VACUUM VESSEL PORT 4 COVER TEST FLANGE WELDMENT			7		
2	SE122-057	VACUUM VESSEL PORT 4 SEAL RETAINER DETAIL			6		
2	SE122-049	VACUUM VESSEL PORT 4 FLANGE DETAIL			5		
2	SE122-104	VACUUM VESSEL PORT 12 COVER TEST FLANGE WELDMENT			4		
2	SE122-019	VACUUM VESSEL PORT 12 SEAL RETAINER DETAIL			3		
2	SE122-018	VACUUM VESSEL PORT 12 FLANGE DETAIL			2		
1	-1	VACUUM VESSEL PERIOD INSPECTION AND LEAK CHECK ASSEMBLY			1		

- NOTES:
1. INTERPRET DIMENSIONS AND TOLERANCES PER ANSI Y14.5M.
 2. DIMENSION ARE IN INCHES.
 3. FABRICATION, INSPECTION, TESTING SHALL BE PERFORMED IN ACCORDANCE WITH SPECIFICATION NCSX-CSPEC-121-02 AND STATEMENT OF WORK NCSX-SOW-121-03.
 4. PROFILE TOLERANCE ON OUTER VACUUM SURFACE IS BILATERAL, i.e. 0.1875 EITHER SIDE OF REFERENCE SURFACE.
 5. THE MINIMUM THICKNESS AFTER FORMING SHALL BE .338. THINNING BELOW THE STOCK THICKNESS SHALL NOT OCCUR OVER MORE THAN 10% OF THE TOTAL POLOIDAL CIRCUMFERENCE OF ANY CROSS-SECTION
 6. PORT LENGTH DIMENSIONS SHOWN ARE FINAL DIMENSIONS AFTER PORTS ARE CUT OFF AND REASSEMBLED. TOLERANCE OF LENGTH IS ± 0.125 . INSPECTED DIMENSION SHALL BE AS SHOWN ON DRAWING PLUS 0.50".
 7. PORT 4 DIMENSIONS SHOWN ARE INSPECTED DIMENSIONS.
 8. SUPPLIED BY PPPL
 9. ALL DIMENSIONS TO BE MET AT DWG SEI20-002.
 10. REDUCING NIPPLES ARE OPTIONAL. BLANK FLANGES MAY BE SUBSTITUTED.
 11. A TOLERANCE DEVIATION OF $+ 3/16 - 7/16$ AT THE PERIMETER OF PORT 4 AND PORT 12 WHICH RETURNS TO THE NOMINAL SHELL PROFILE WITHIN 8" OF THE PERIMETER OF THE PORT, WILL BE ACCEPTED.
 12. A TOLERANCE DEVIATION OF $+ 3/16 - 5/16$ AT THE PERIMETER OF THE ROUND PORTS, NB PORT, AND THE DOME PORT WHICH RETURNS TO THE NOMINAL SHELL PROFILE WITHIN 8" OF THE PERIMETER OF THE PORT, WILL BE ACCEPTED.

NO REPRESENTATION OR WARRANTY, EXPRESSED OR IMPLIED, IS MADE AS TO THE ACCURACY, COMPLETENESS OR USEFULNESS OF THE INFORMATION OR STATEMENTS CONTAINED IN THESE DRAWINGS, OR THAT THE USE OR DISCLOSURE OF ANY INFORMATION, APPARATUS, METHOD OR PROCESS DISCLOSED IN THESE DRAWINGS MAY NOT INFRINGE PRIVATE RIGHTS OF OTHERS. NO LIABILITY IS ASSUMED WITH RESPECT TO THE USE OF, OR FOR DAMAGES RESULTING FROM THE USE OF, ANY INFORMATION, APPARATUS, METHOD OR PROCESS DISCLOSED IN THESE DRAWINGS. DRAWINGS MADE AVAILABLE FOR INFORMATION TO BIDDER ARE NOT TO BE USED FOR OTHER PURPOSES, AND ARE TO BE RETURNED UPON REQUEST OF THE FORWARDING CONTRACTOR.

P THIS DRAWING PRODUCED ON PRO-ENGINEER

RELEASED FOR FABRICATION / INSTALLATION
 PPPL Drafting:

REVISED PER ECN-4945 & ECN-4961 GHJ 2/28/03 MJC

SCALE: .06 WEIGHT= 7147 LBS

REV	DESCRIPTION	BY	DATE	CHK	DEPT	DATE	PE	REQ	DATE	ORNL	DOE	DATE
1	SHT 15 BALLOON WAS 51											
2	SHT 13 CHG'D NOTE 6 & SHT 1 ADDED NOTES 10, 11, & 12											

WELDING ENGINEER
 APPROVED R. PARSELLS DATE: 6/04

SCALE NOTED

DESIGN	DATE	BY	DATE	CHK	DEPT	DATE	PE	REQ	DATE	ORNL	DOE	DATE
DES. P. L. GORANSON	12/02											
DRW. M. J. COLE & G. H. JONES	12/02											

UT-BATTELLE
 NATIONAL COMPACT STELLARATOR EXPERIMENT
 VACUUM VESSEL PERIOD INSPECTION AND LEAK CHECK ASSEMBLY

VERSION NO.	PLANT	BLDG	FL	SHT OF	TYPE	CLASS
5	X-10	5700	3	1	19	A

SEI20-004
 Fabrication

FOR NOTES AND PARTS LIST SEE SHEET 1

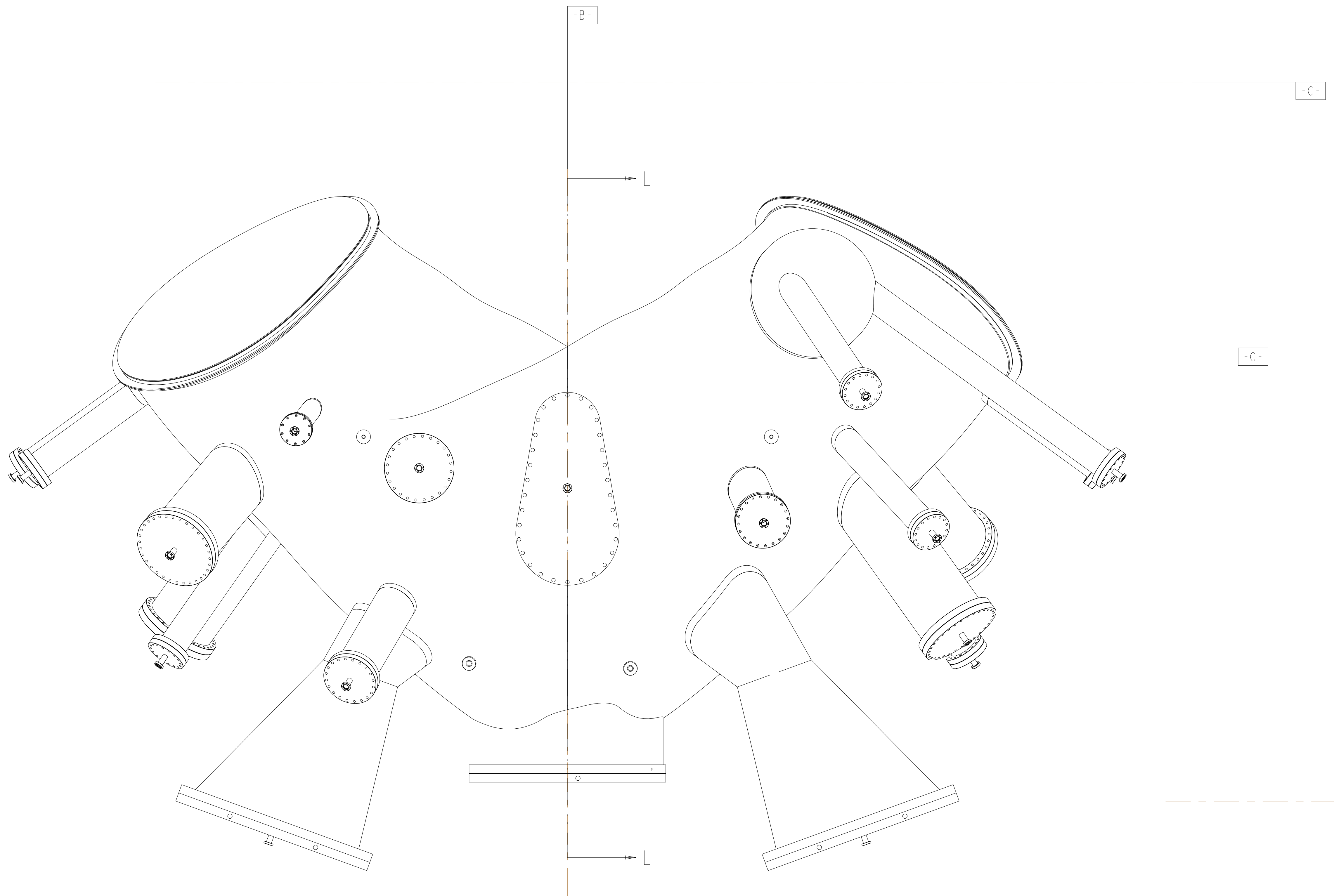

TOP VIEW

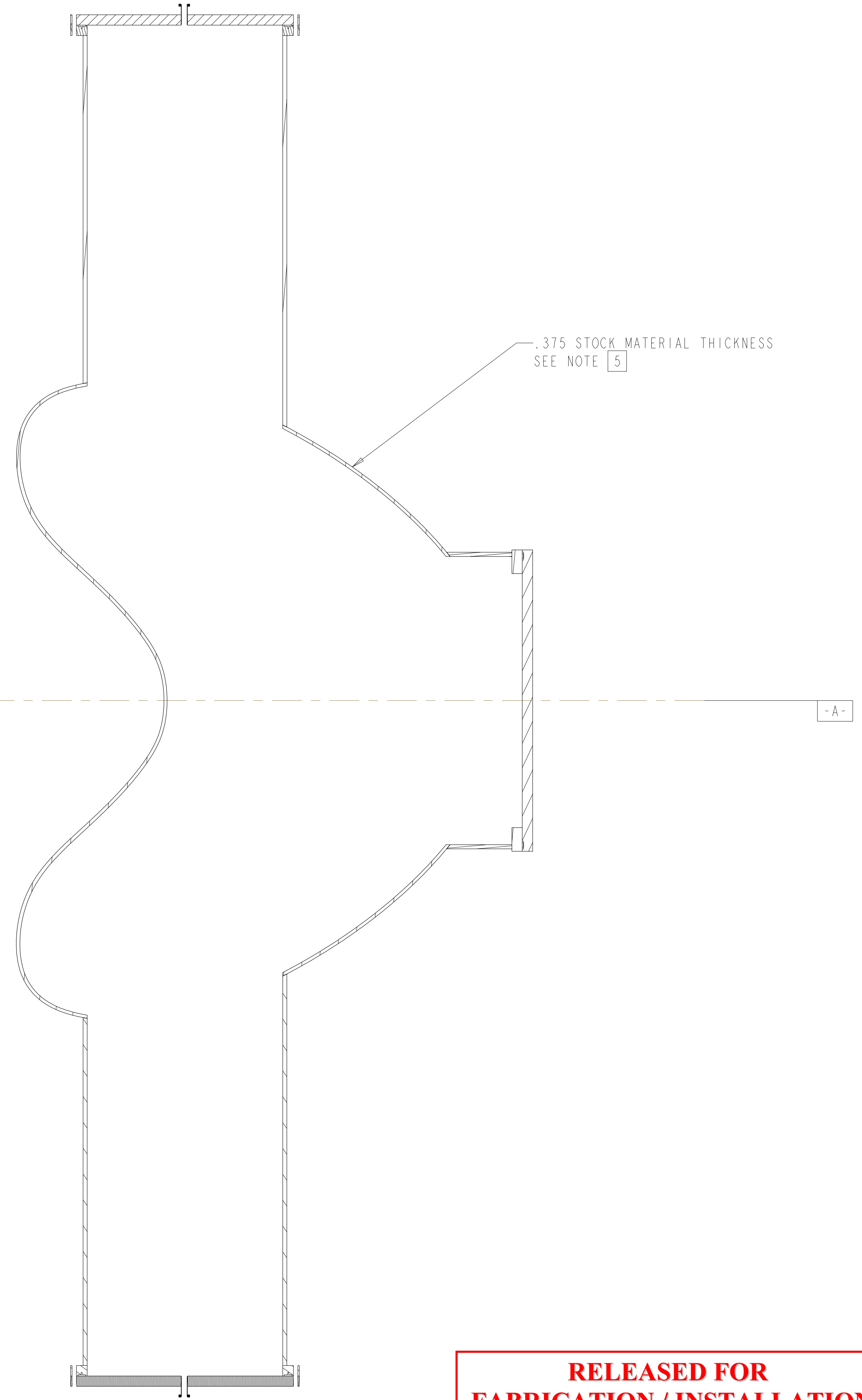

SECTION L-L
 VESSEL THICKNESS

**RELEASED FOR
 FABRICATION / INSTALLATION**
 PPPL Drafting:

Oak Ridge National Laboratory managed for the DEPARTMENT OF ENERGY under U.S. GOVERNMENT contract DE-AC05-00OR22725 UT-BATTELLE, LLC, Oak Ridge, Tennessee PROJECT NAME						
NATIONAL COMPACT STELLERATOR EXPERIMENT VACUUM VESSEL PERIOD INSPECTION AND LEAK CHECK ASSEMBLY						
VERSION NO.	PLANT	BLDG	FL	SHT OF	TYPE	CLASS
5	X-10	5700	3	2 19	A	U
RELEASE LEVEL		SE120-004			REV	
Fabrication					2	

H
G
F
E
D
C
B
A

FOR NOTES AND PARTS LIST SEE SHEET 1

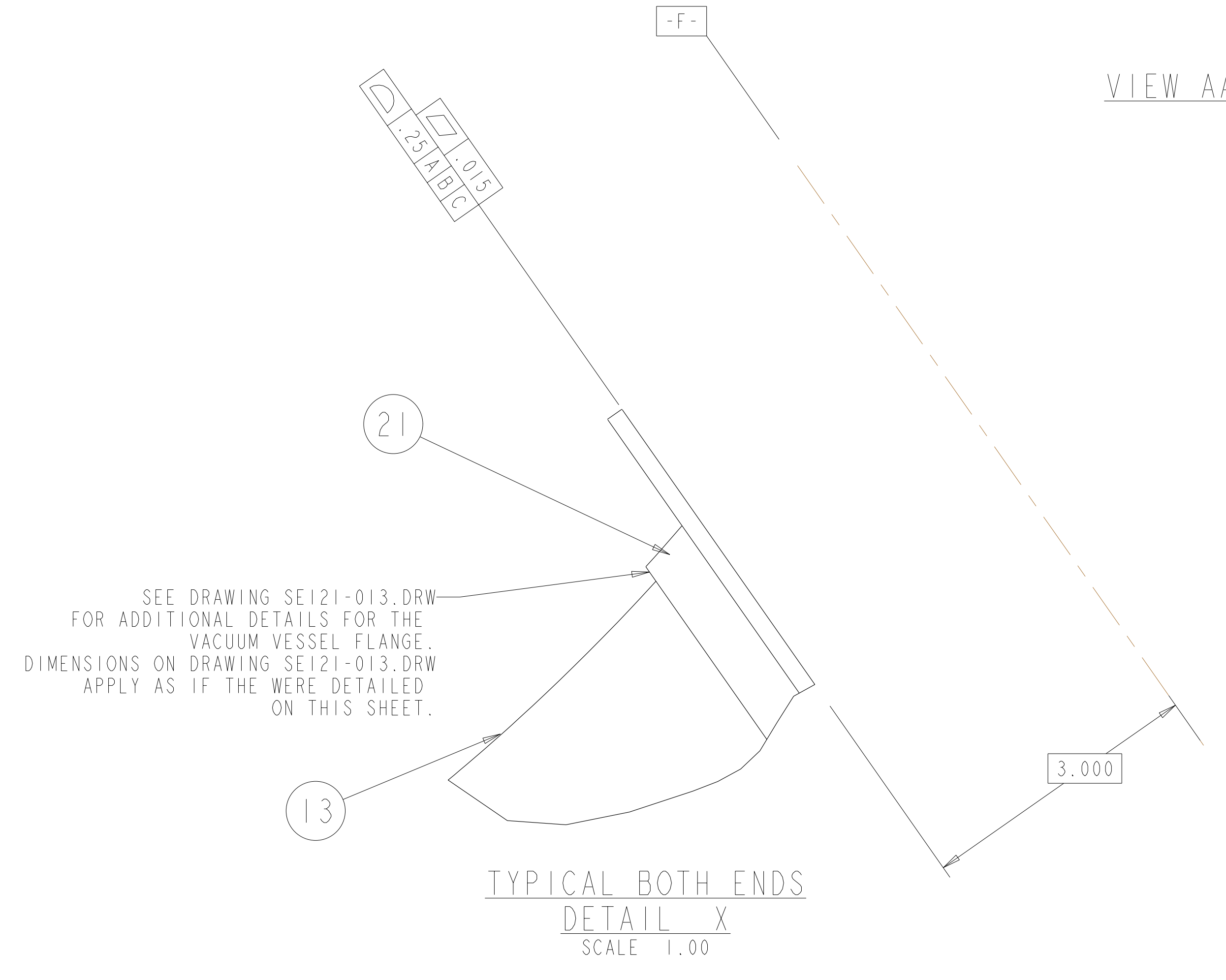
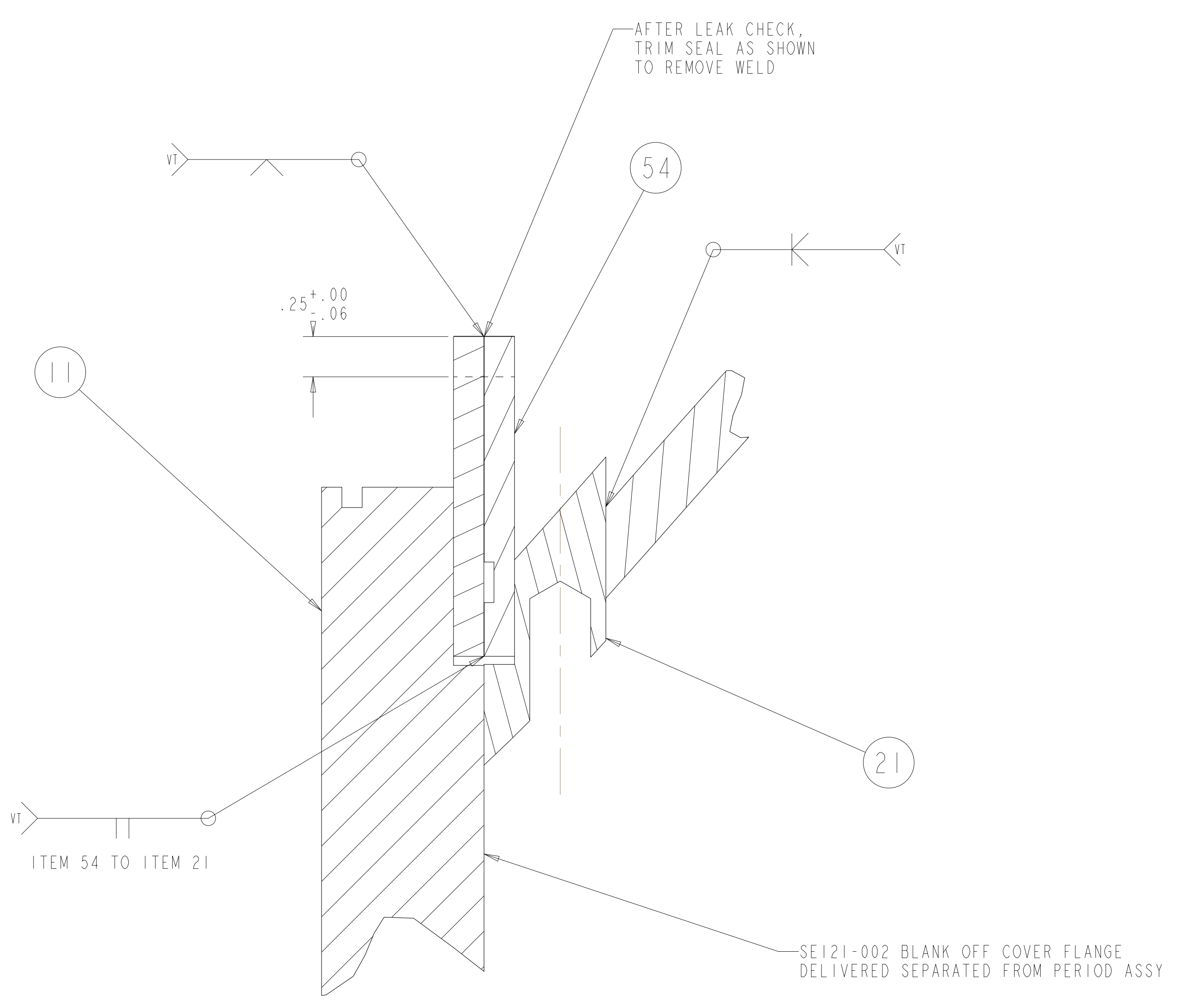
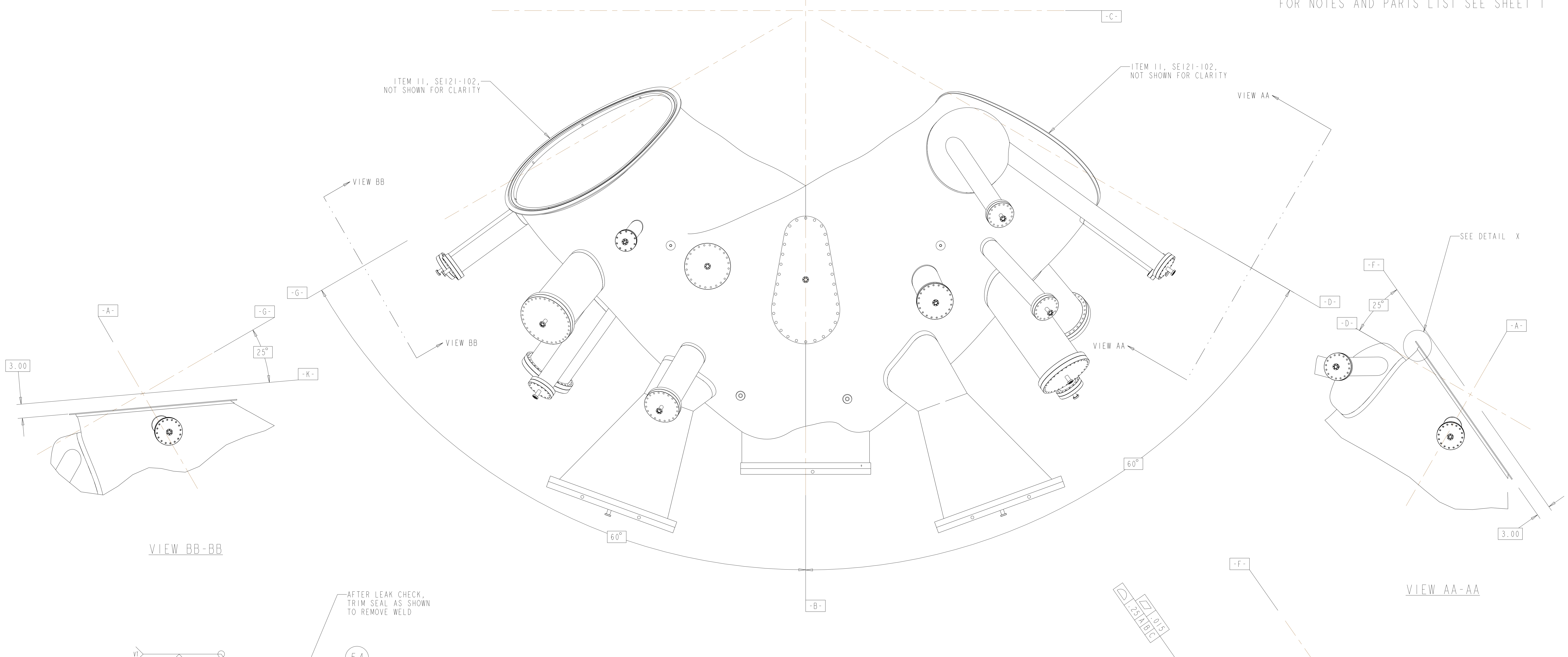

RELEASED FOR FABRICATION / INSTALLATION
PPPL Drafting:

UT-BATTELLE		Oak Ridge National Laboratory managed for the DEPARTMENT OF ENERGY under U.S. GOVERNMENT contract DE-AC05-00OR22725 UT-BATTELLE, LLC, Oak Ridge, Tennessee					
PROJECT NAME							
NATIONAL COMPACT STELLARATOR EXPERIMENT							
VACUUM VESSEL PERIOD INSPECTION AND LEAK CHECK ASSEMBLY							
VERSION NO.	PLANT	BLDG	FL	SHT OF	TYPE	CLASS	
5	X-10	5700	3	3 19	A	U	
RELEASE LEVEL	Fabrication					SE120-004	REV 2

FOR PARTS LIST AND NOTES SEE SHEET 1.

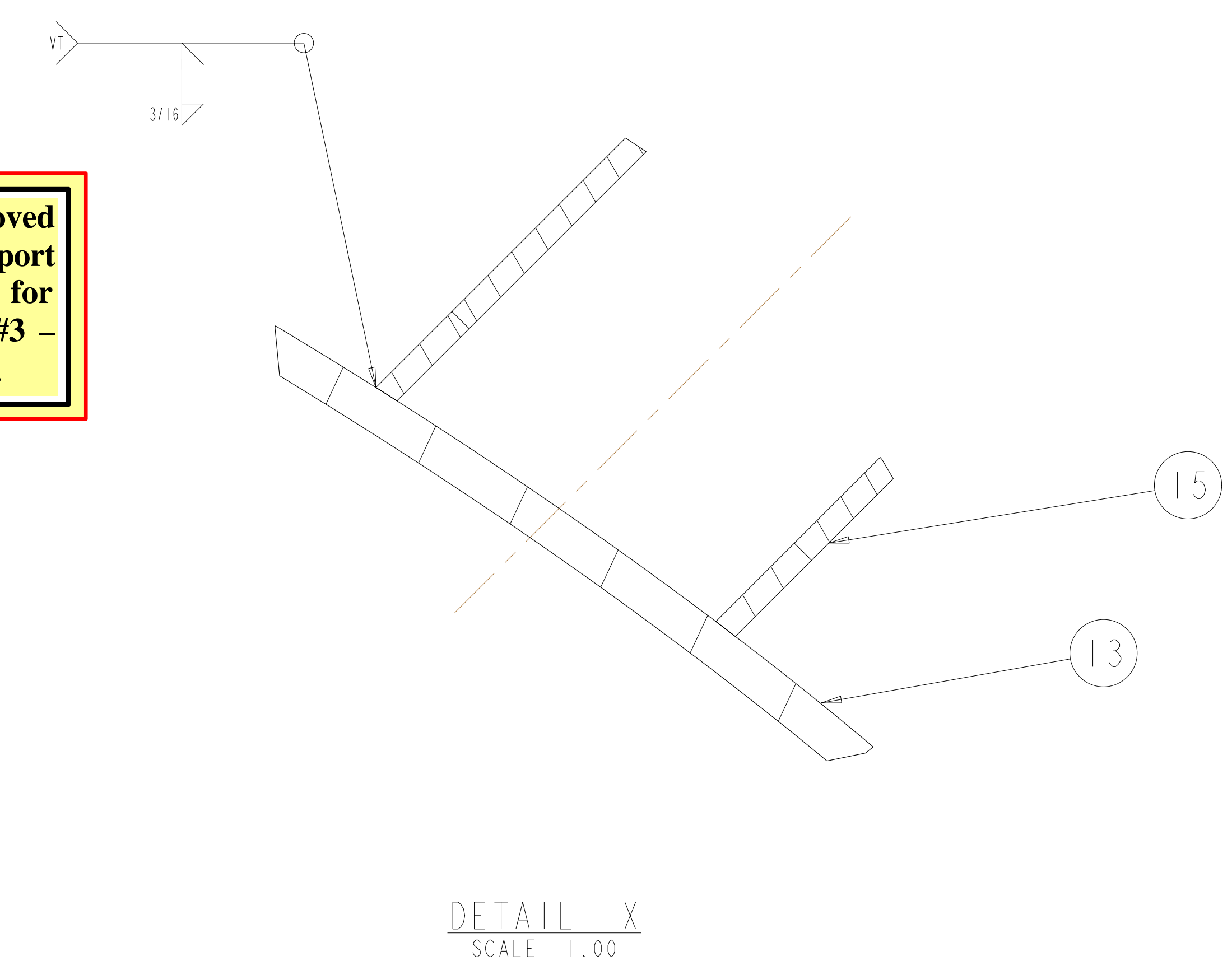
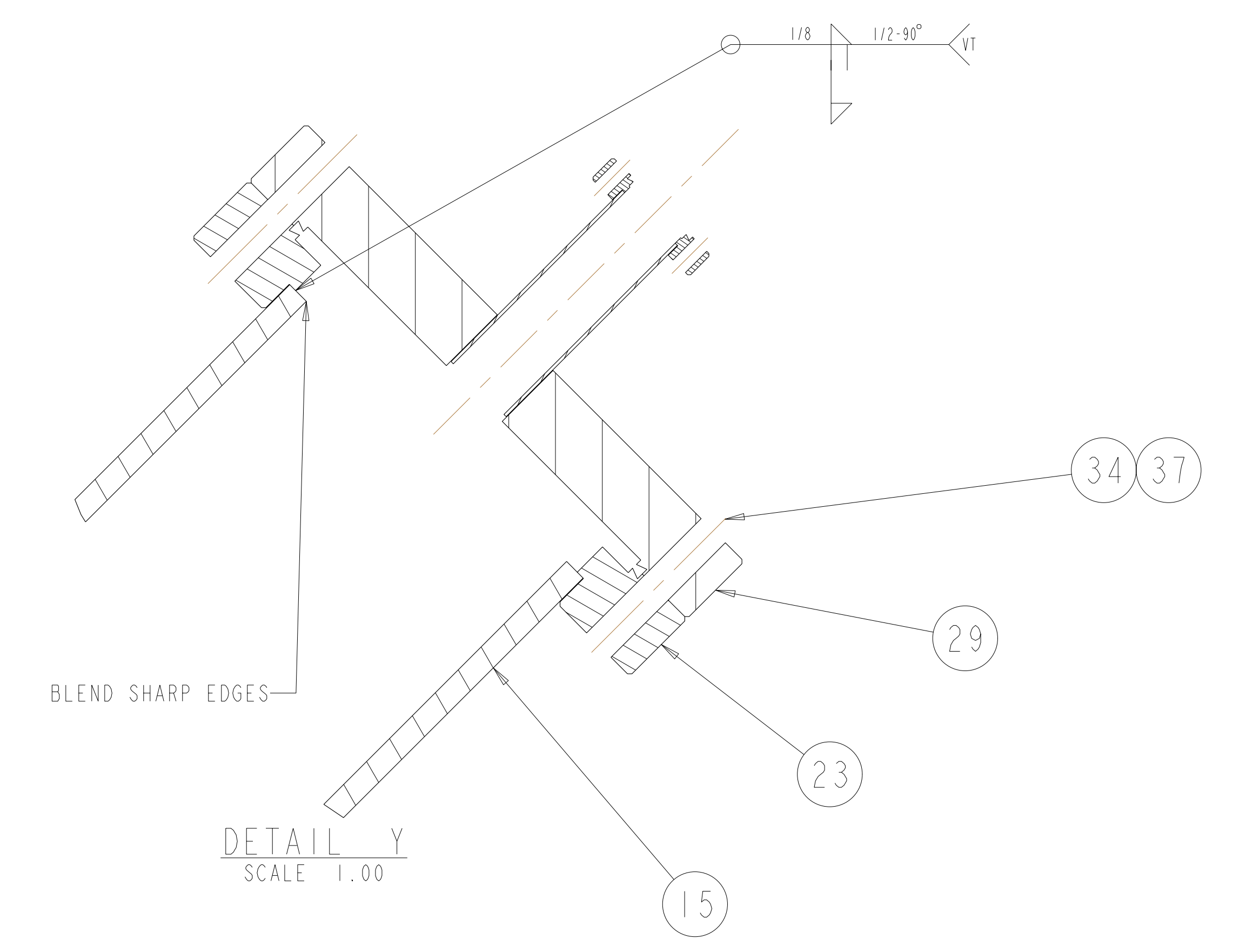
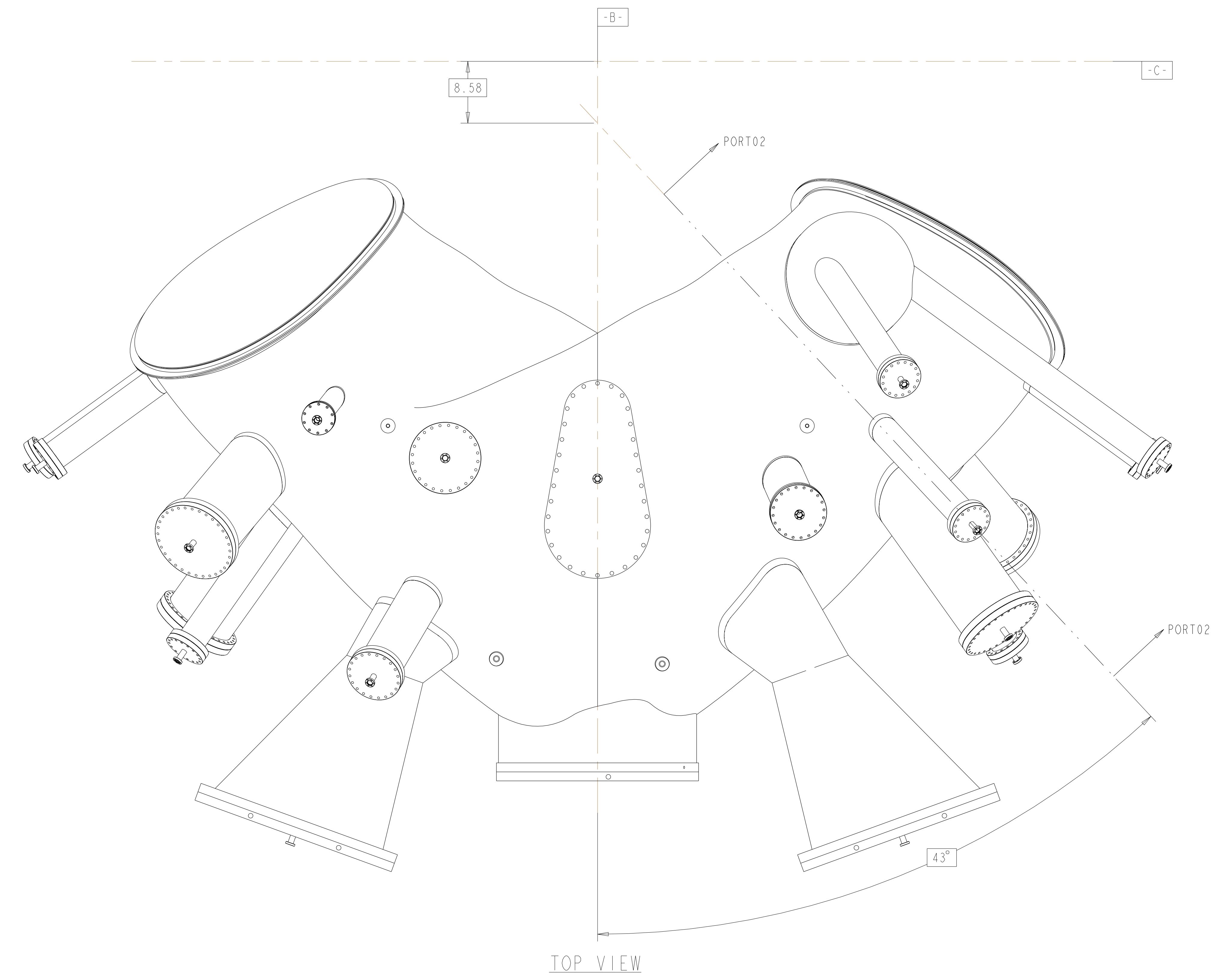

Rev 2-e: ECN-5021 (RFD-12-017) approved alternate methods for welding the port extensions to the VVSA (See ECN-5021 for details). - Only applicable to VVSA #3 - VVSA #1 and #2 covered by NCR 19464.

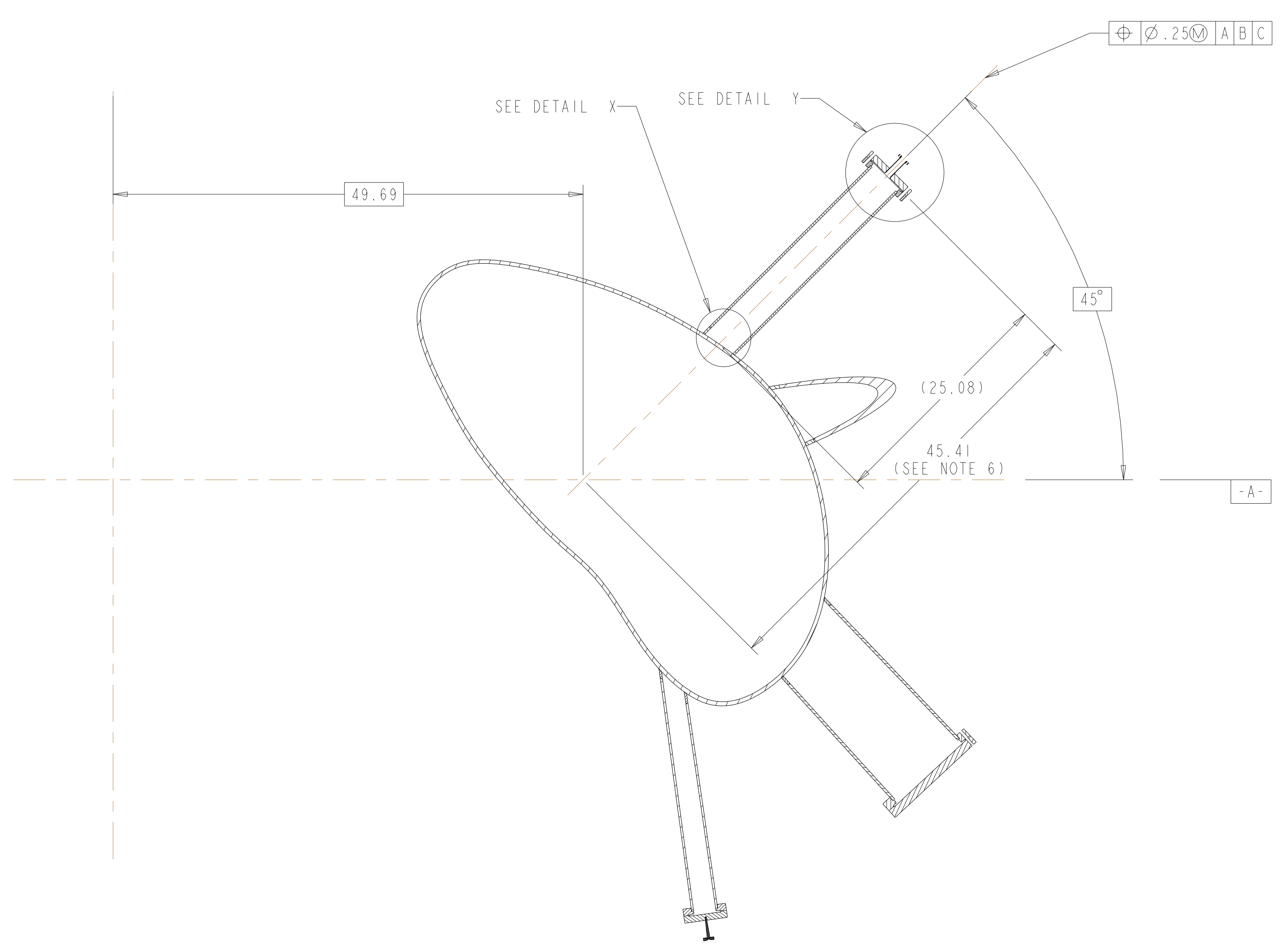

RELEASED FOR FABRICATION / INSTALLATION
PPPL Drafting:

UT-BATTELLE		Oak Ridge National Laboratory managed for the DEPARTMENT OF ENERGY under U.S. GOVERNMENT contract DE-AC05-00OR22725 UT-BATTELLE, LLC, Oak Ridge, Tennessee					
NATIONAL COMPACT STELLARATOR EXPERIMENT							A
VACUUM VESSEL PERIOD INSPECTION AND LEAK CHECK ASSEMBLY							
VERSION NO.	PLANT	BLDG	FL	SHT OF	TYPE	CLASS	
5	X-10	5700	3	4	19	A	U
RELEASE LEVEL	SEI20-004					REV	2
Fabrication							

H
G
F
E
D
C
B
A

FOR PARTS LIST AND NOTES SEE SHEET 1.

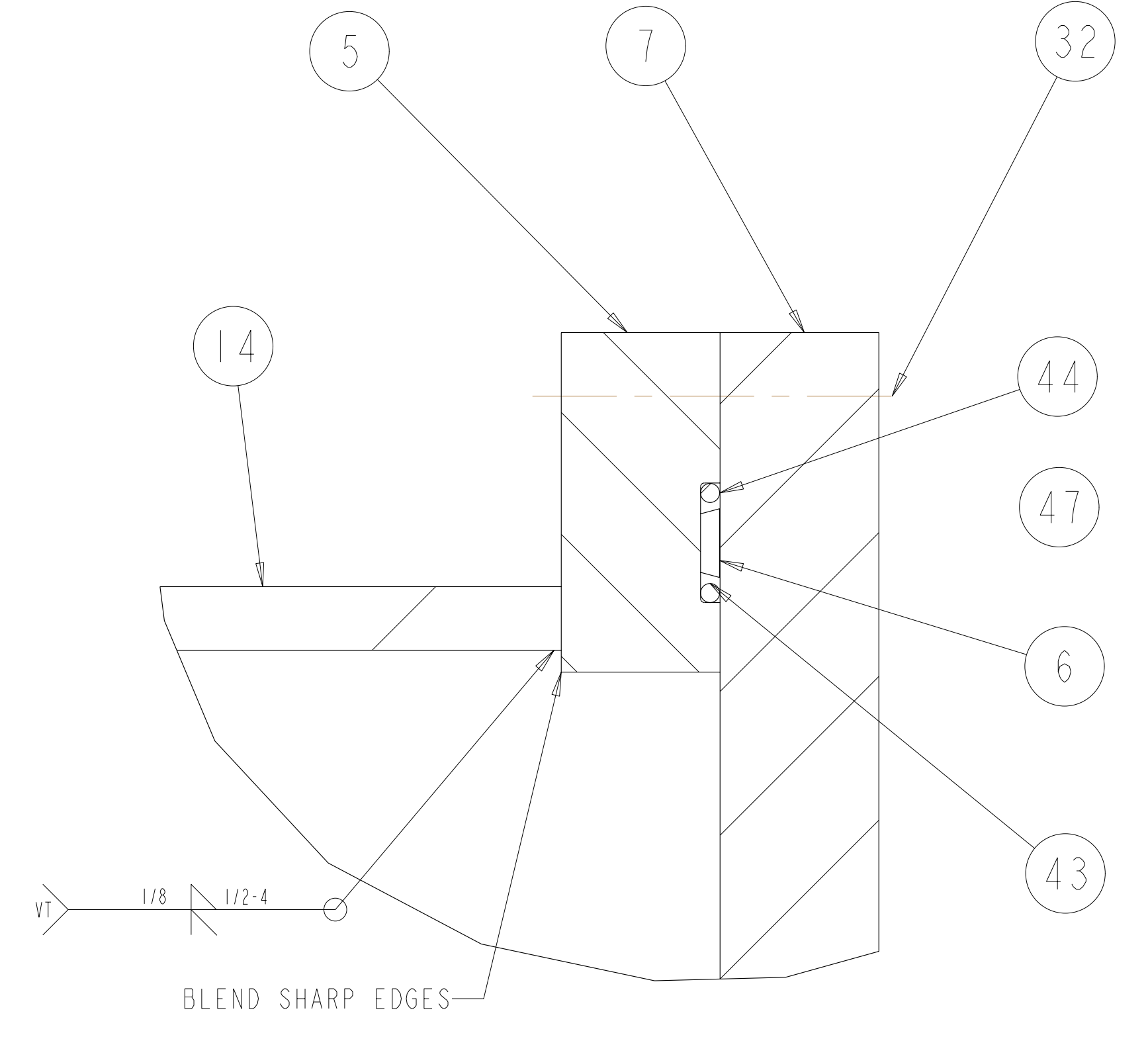
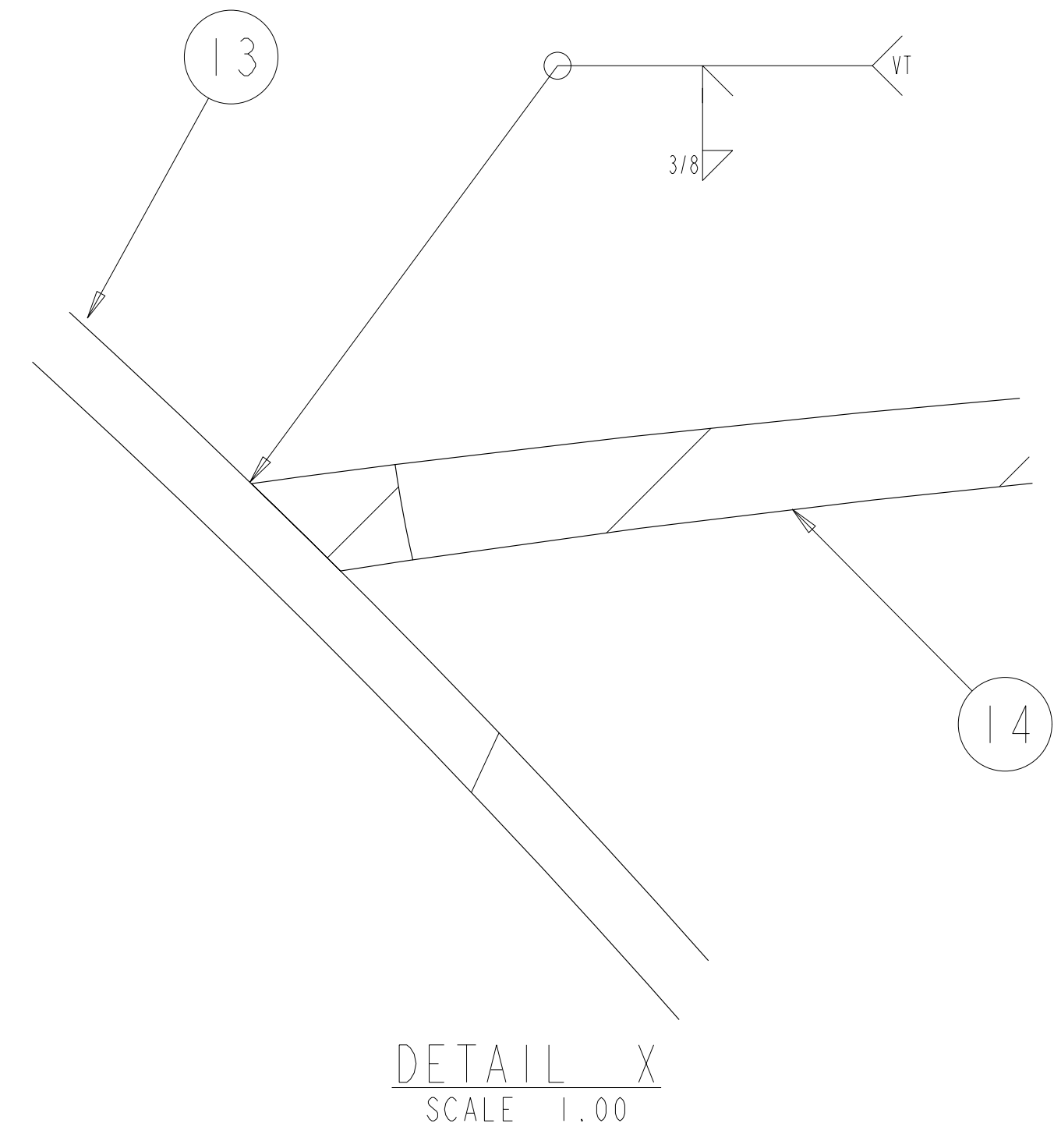
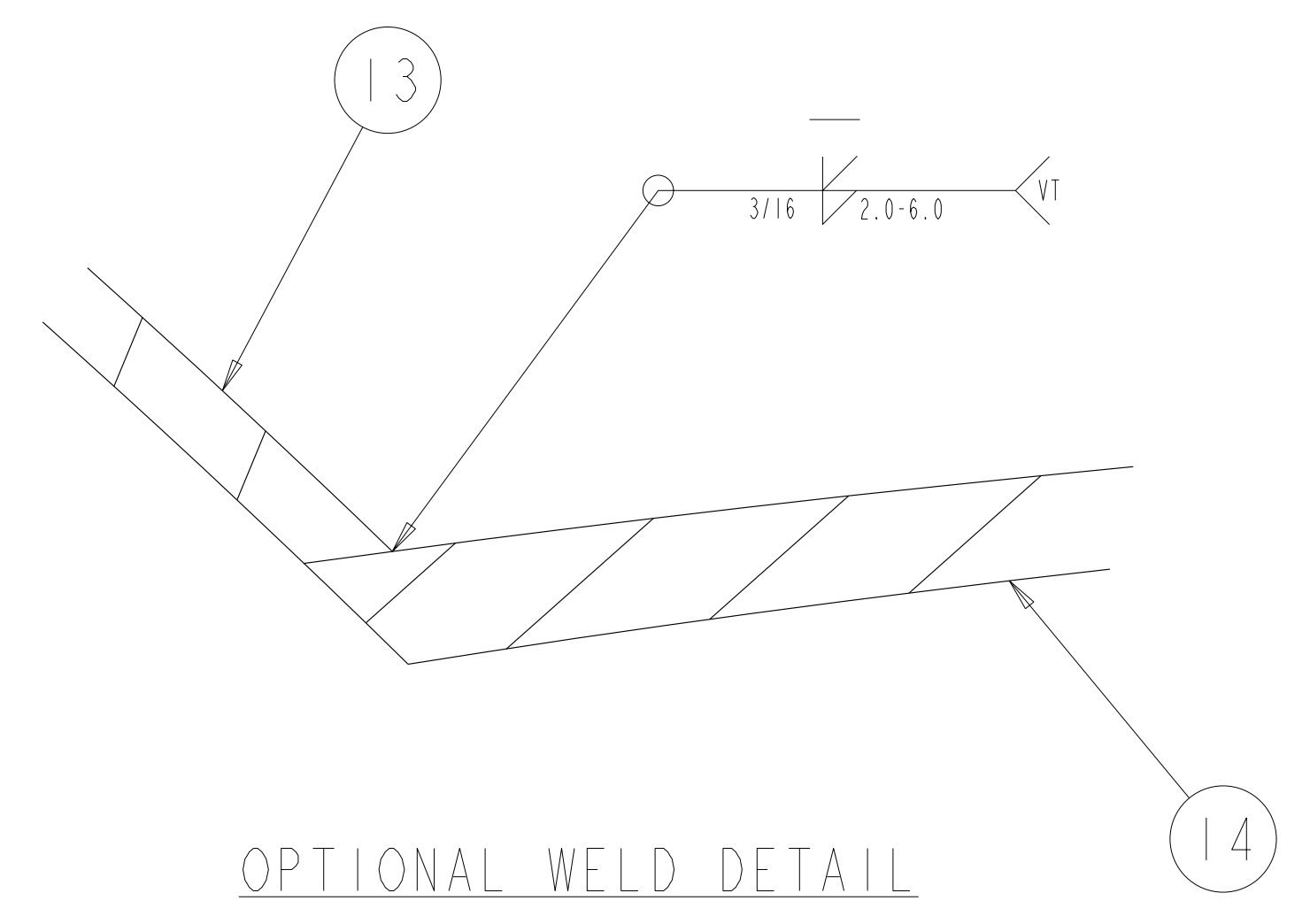
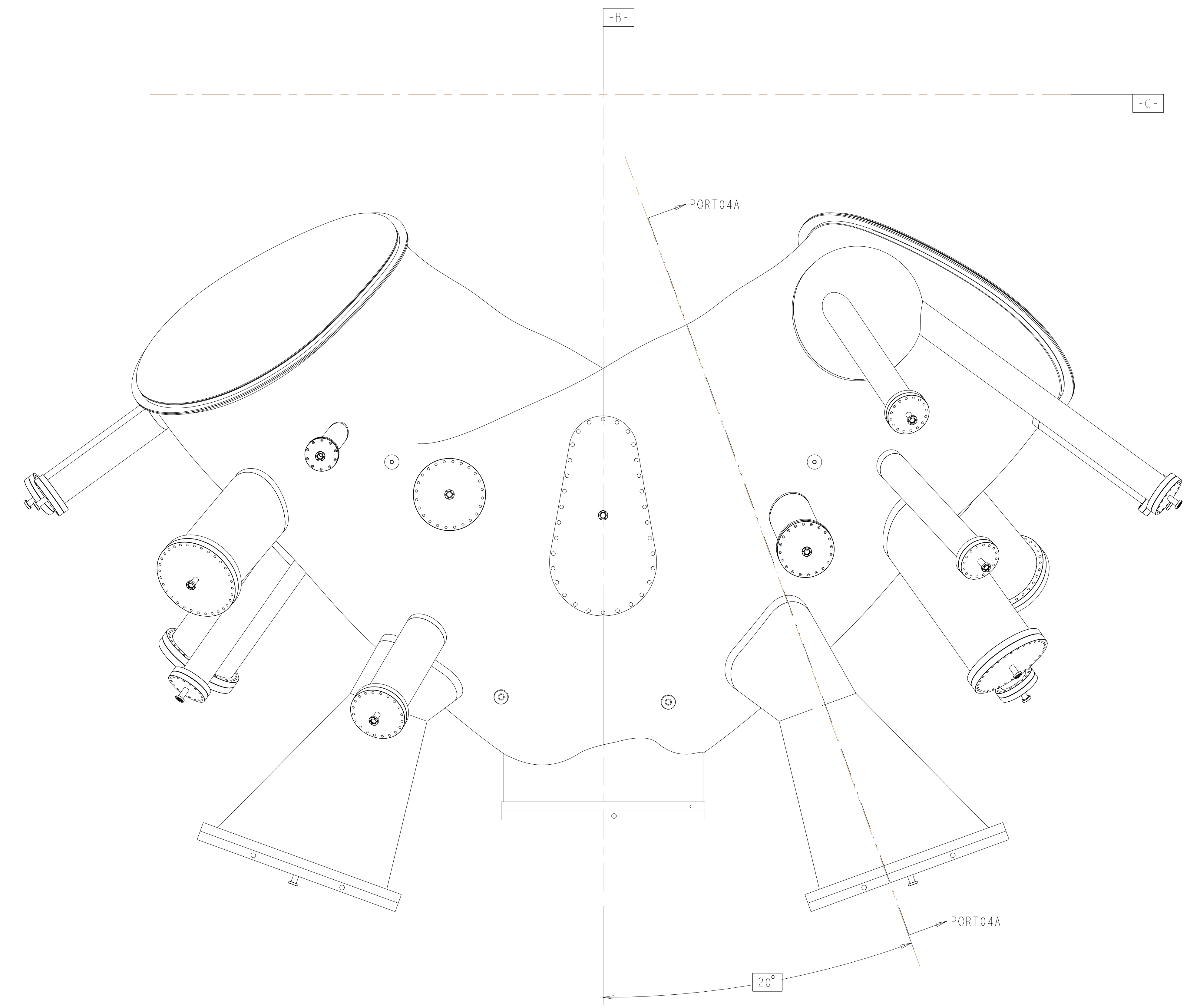

DETAIL Y
SCALE 1.00

TOP VIEW

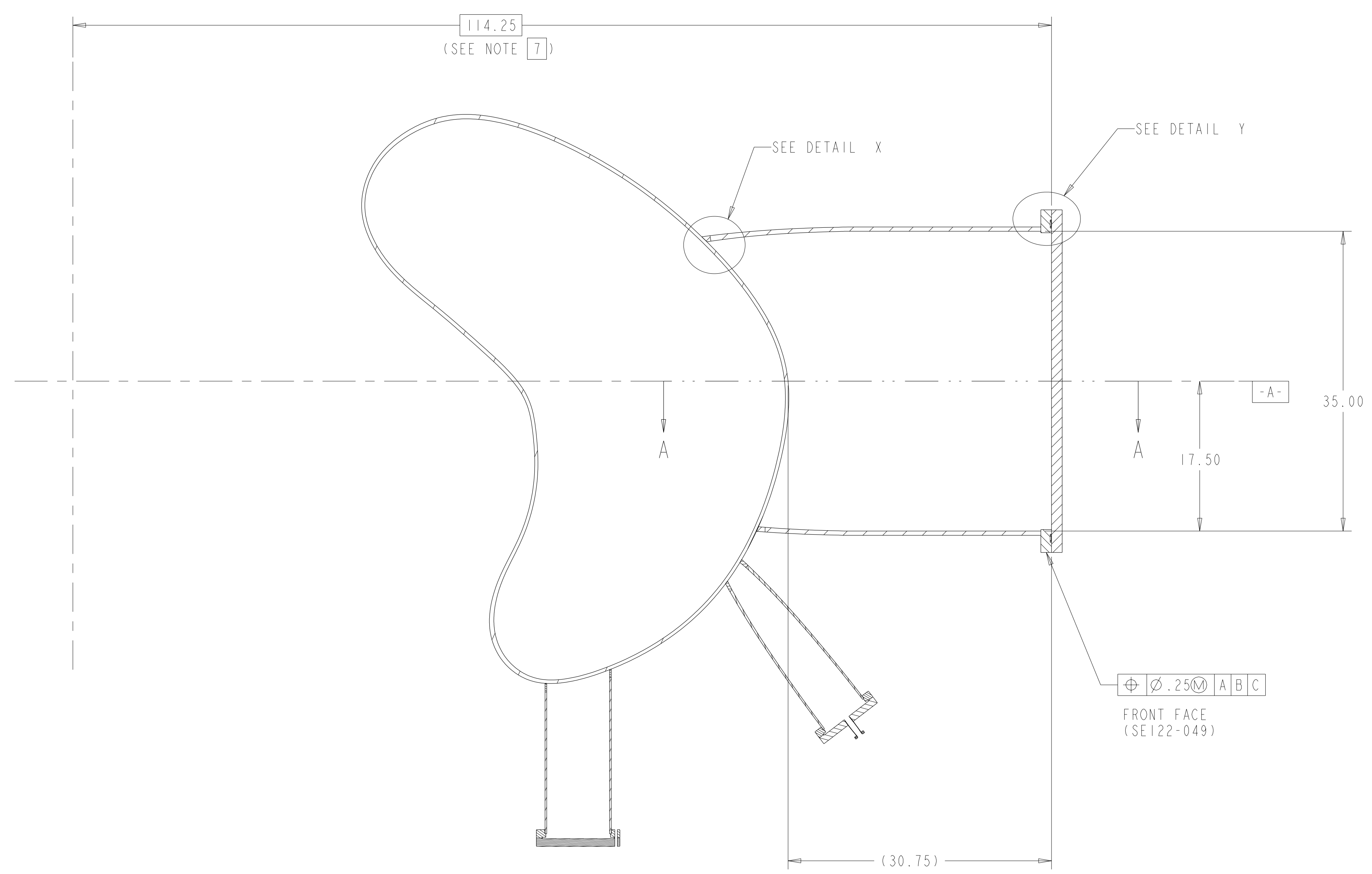

TYPICAL PORT 4A AND 4B
SECTION PORT04A-PORT04A

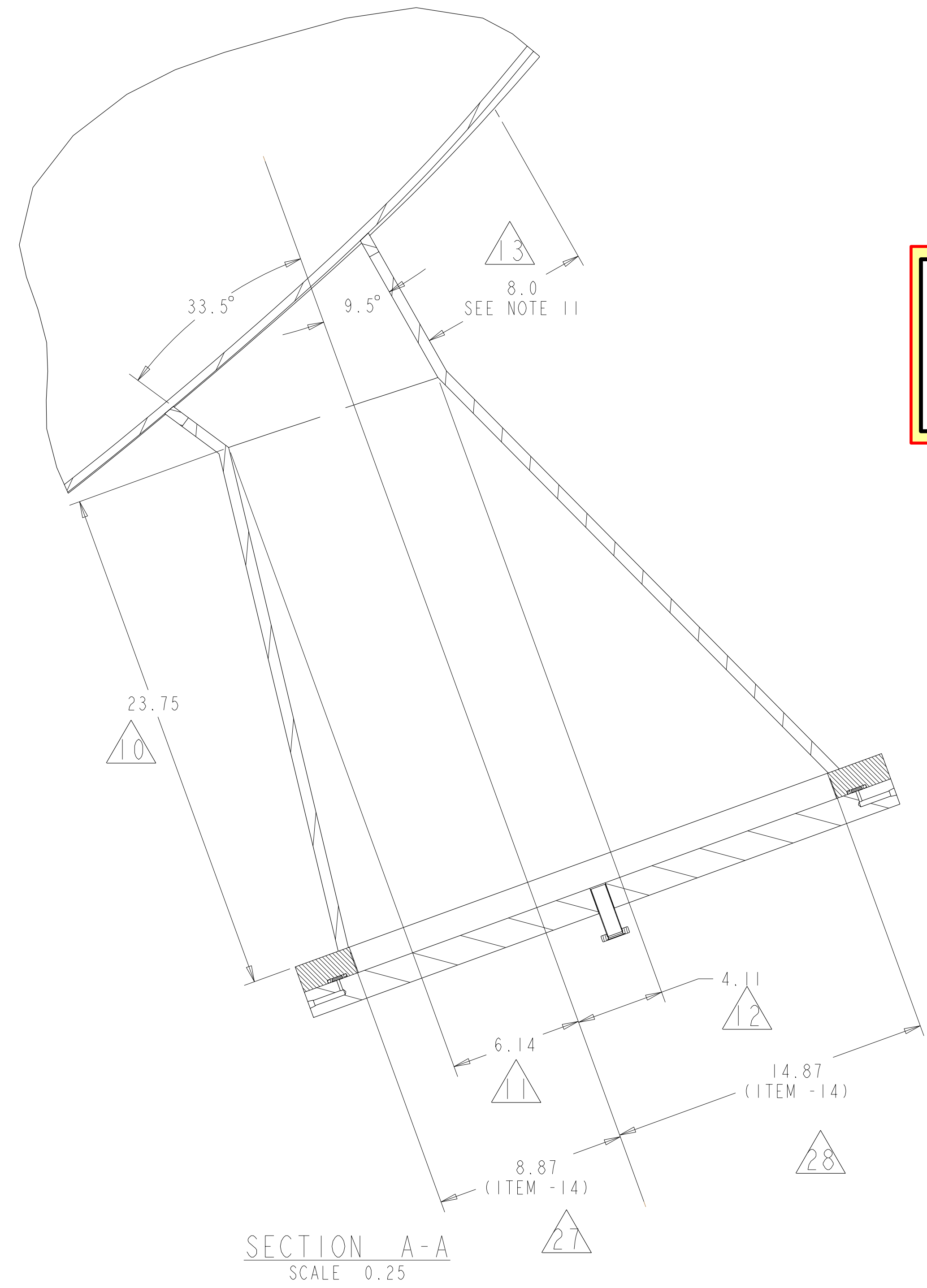

SECTION A-A
SCALE 0.25

Rev 2-e: ECN-5021 (RFD-12-017) approved alternate methods for welding the port extensions to the VVSA (See ECN-5021 for details). - Only applicable to VVSA #3 - VVSA #1 and #2 covered by NCR 19464.

RELEASED FOR FABRICATION / INSTALLATION
PPPL Drafting:

UT-BATTELLE							Oak Ridge National Laboratory managed for the DEPARTMENT OF ENERGY under U.S. GOVERNMENT contract DE-AC05-00OR22725 UT-BATTELLE, LLC. Oak Ridge, Tennessee			
NATIONAL COMPACT STELLERATOR EXPERIMENT							PROJECT NAME			
VACUUM VESSEL							PERIOD INSPECTION AND LEAK CHECK ASSEMBLY			
VERSION NO.	PLANT	BLDG	FL	SHT OF	TYPE	CLASS				
5	X-10	5700	3	5	19	A				
RELEASE LEVEL							Fabrication			
							SE120-004		REV 2	

H
G
F
E
D
C
B
A

FOR PARTS LIST AND NOTES SEE SHEET 1.

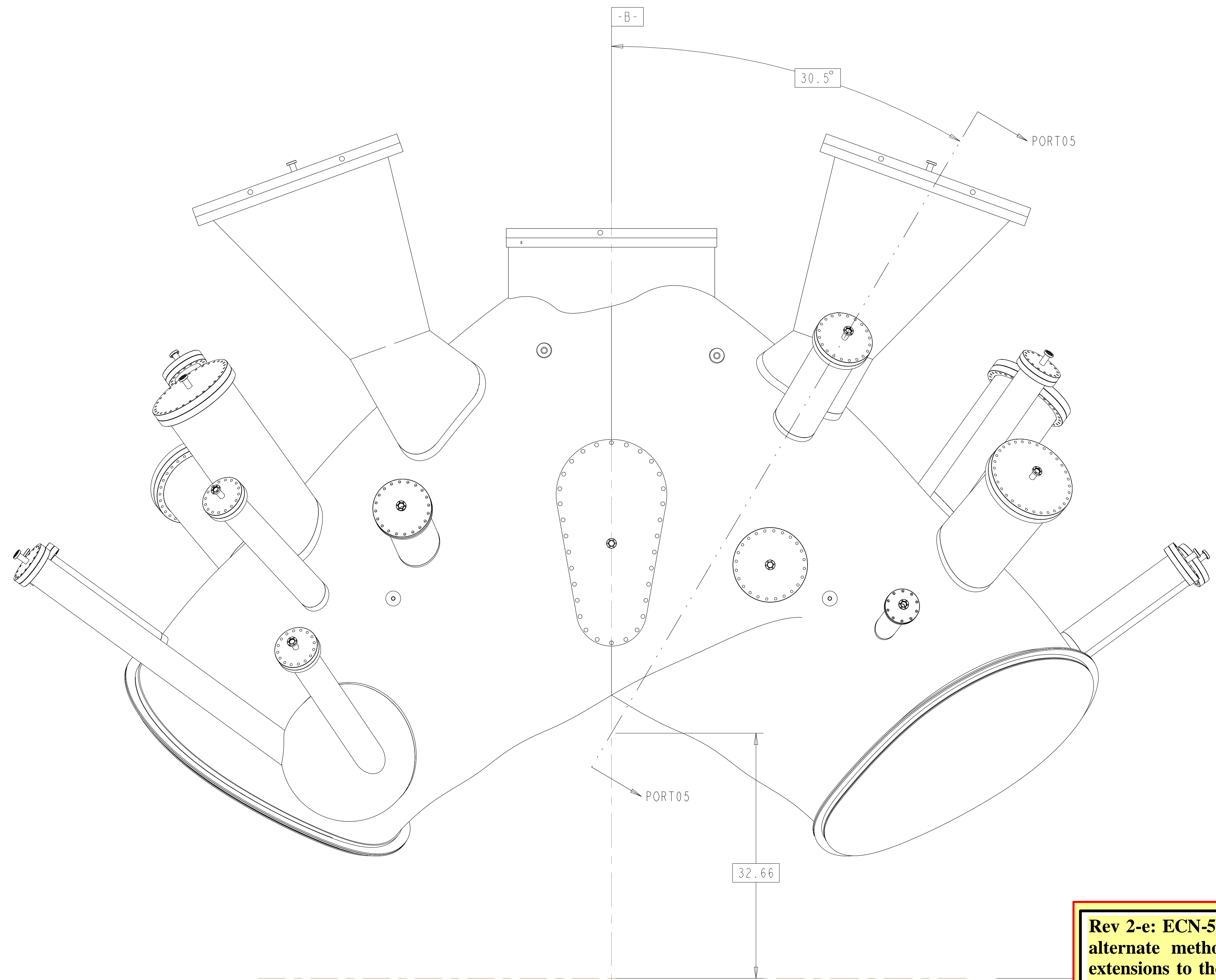

BOTTOM VIEW

Rev 2-e: ECN-5021 (RFD-12-017) approved alternate methods for welding the port extensions to the VVSA (See ECN-5021 for details). - Only applicable to VVSA #3 - VVSA #1 and #2 covered by NCR 19464.

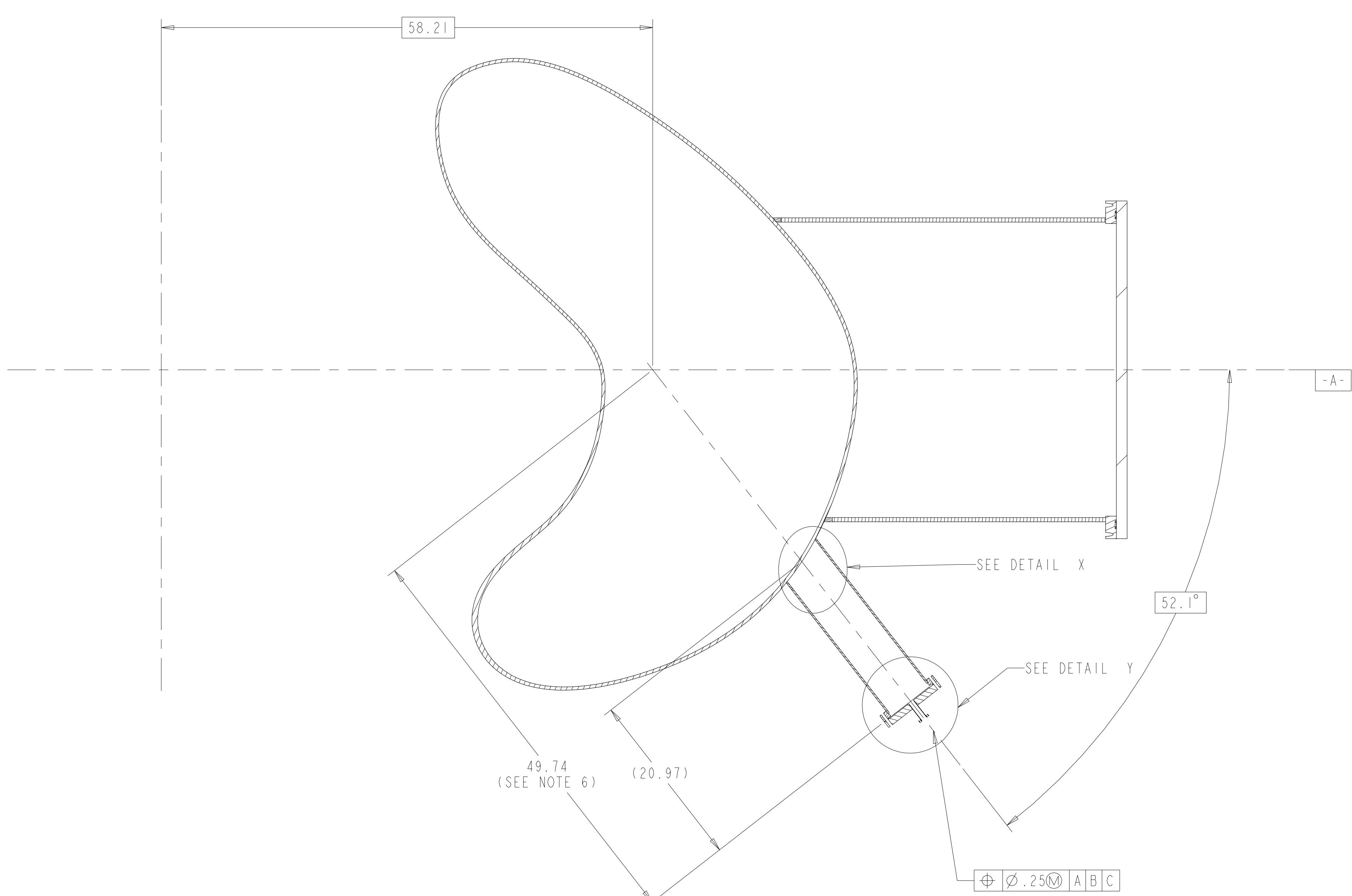

TYPICAL PORT 5A AND 5B SECTION PORT05-PORT05

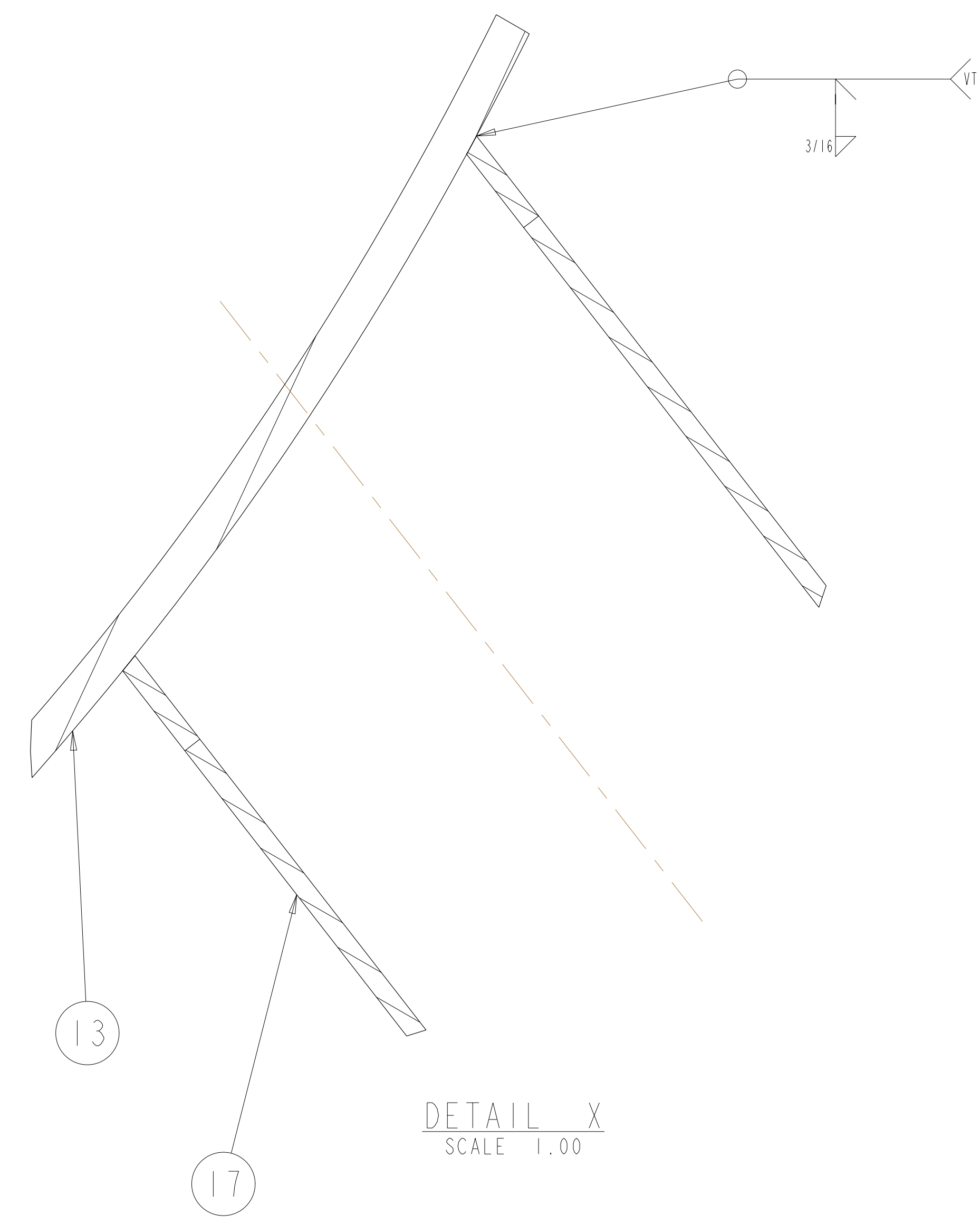

DETAIL X
SCALE 1.00

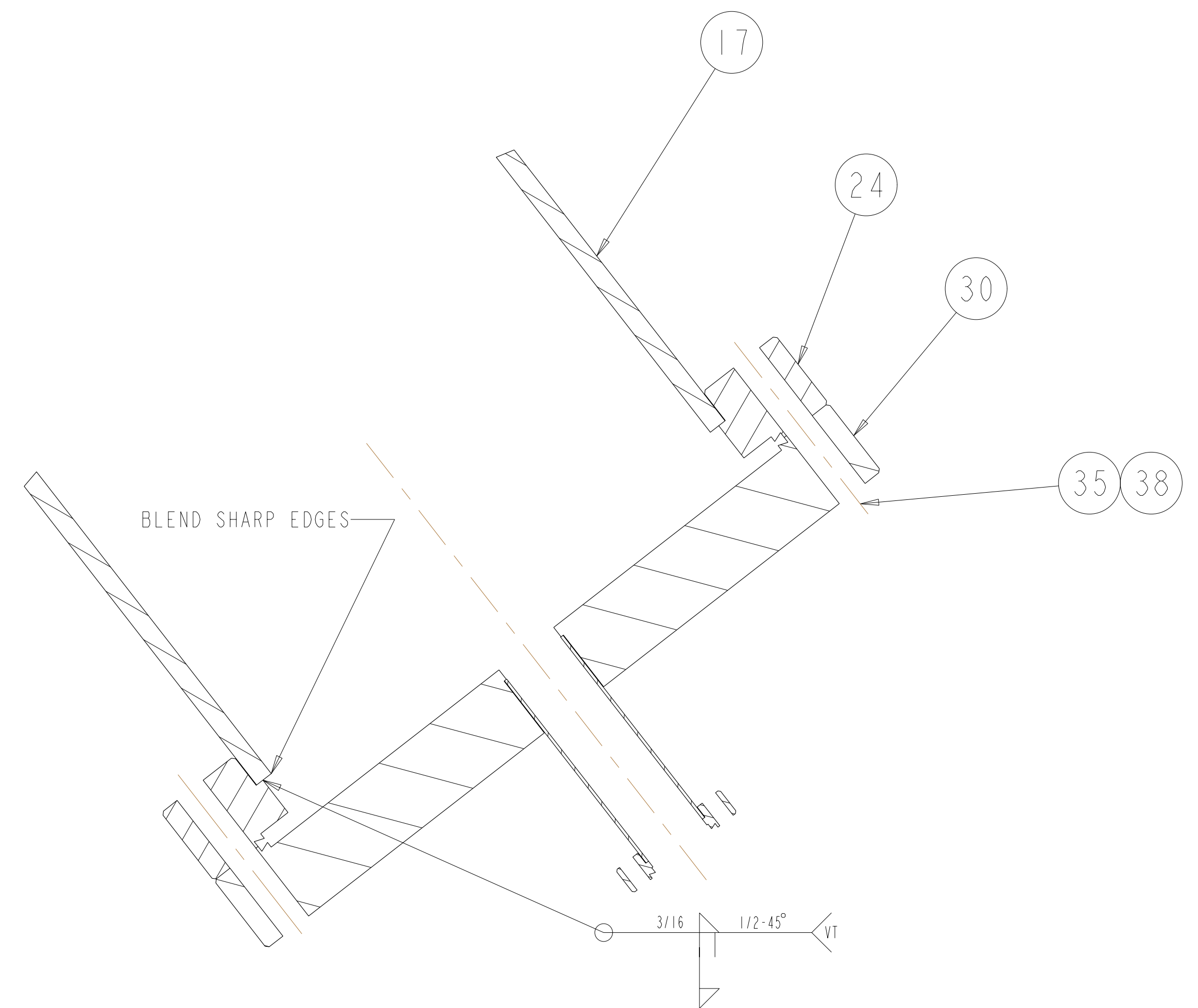

DETAIL Y
SCALE 1.00

RELEASED FOR FABRICATION / INSTALLATION
 PPPL Drafting:

UT-BATTELLE		Oak Ridge National Laboratory managed for the DEPARTMENT OF ENERGY under U.S. GOVERNMENT contract DE-AC05-00OR22725 UT-BATTELLE, LLC, Oak Ridge, Tennessee					
NATIONAL COMPACT STELLARATOR EXPERIMENT							
VACUUM VESSEL							
PERIOD INSPECTION AND LEAK CHECK ASSEMBLY							
VERSION NO.	PLANT	BLDG	FL	SHT OF	TYPE	CLASS	
5	X-10	5700	3	6	19	A	U
RELEASE LEVEL	SE120-004						REV
Fabrication							2

H
G
F
E
D
C
B
A

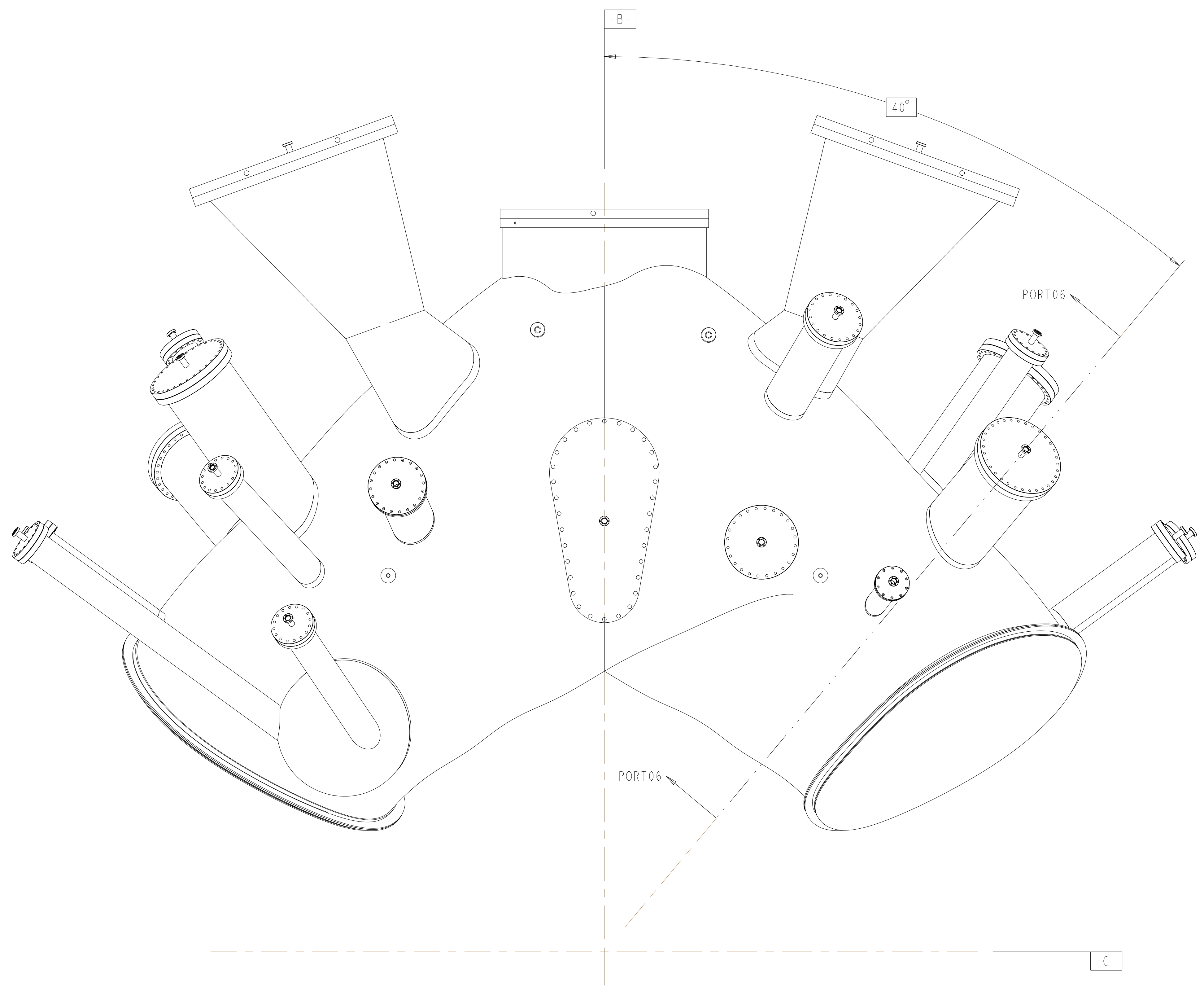

BOTTOM VIEW

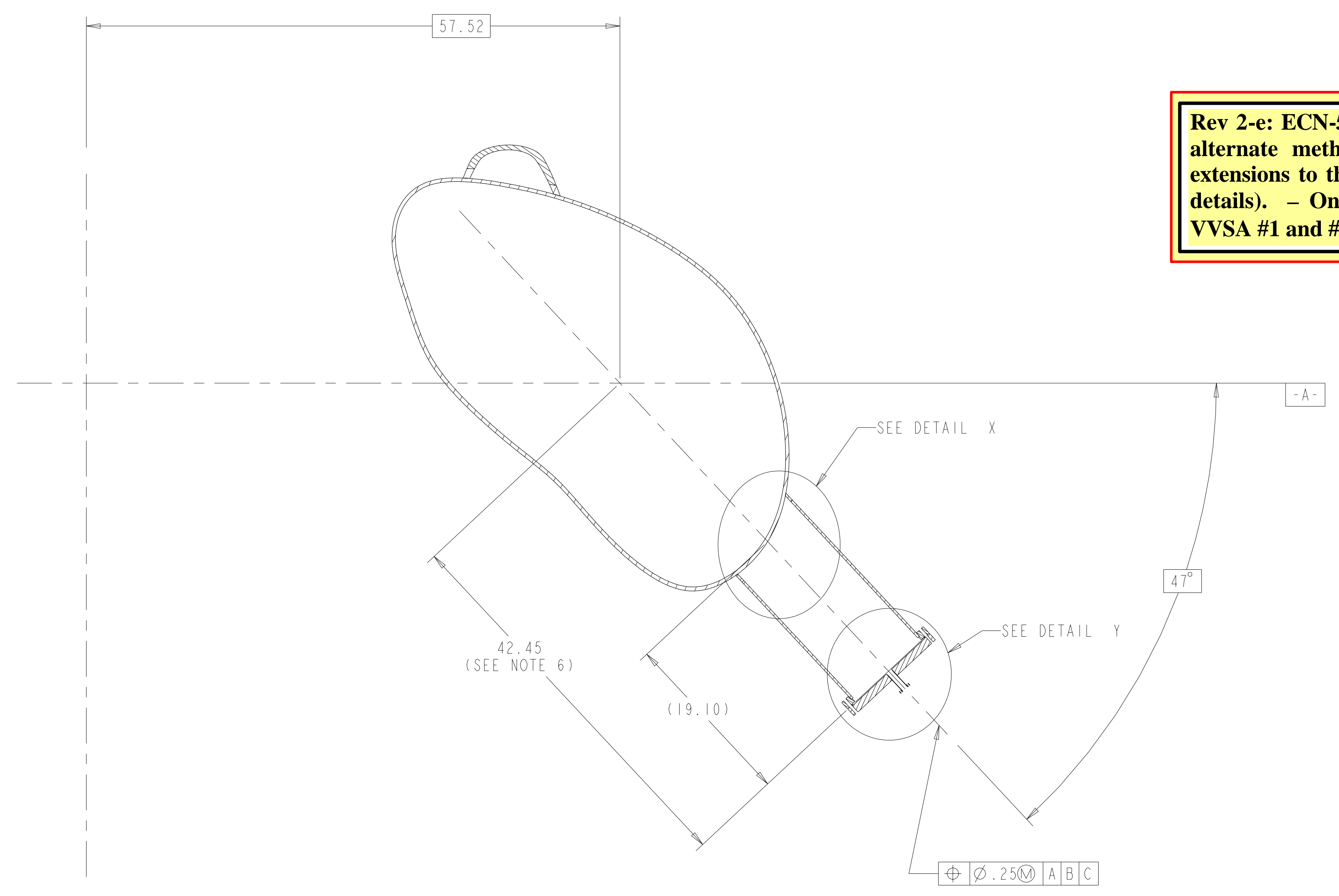
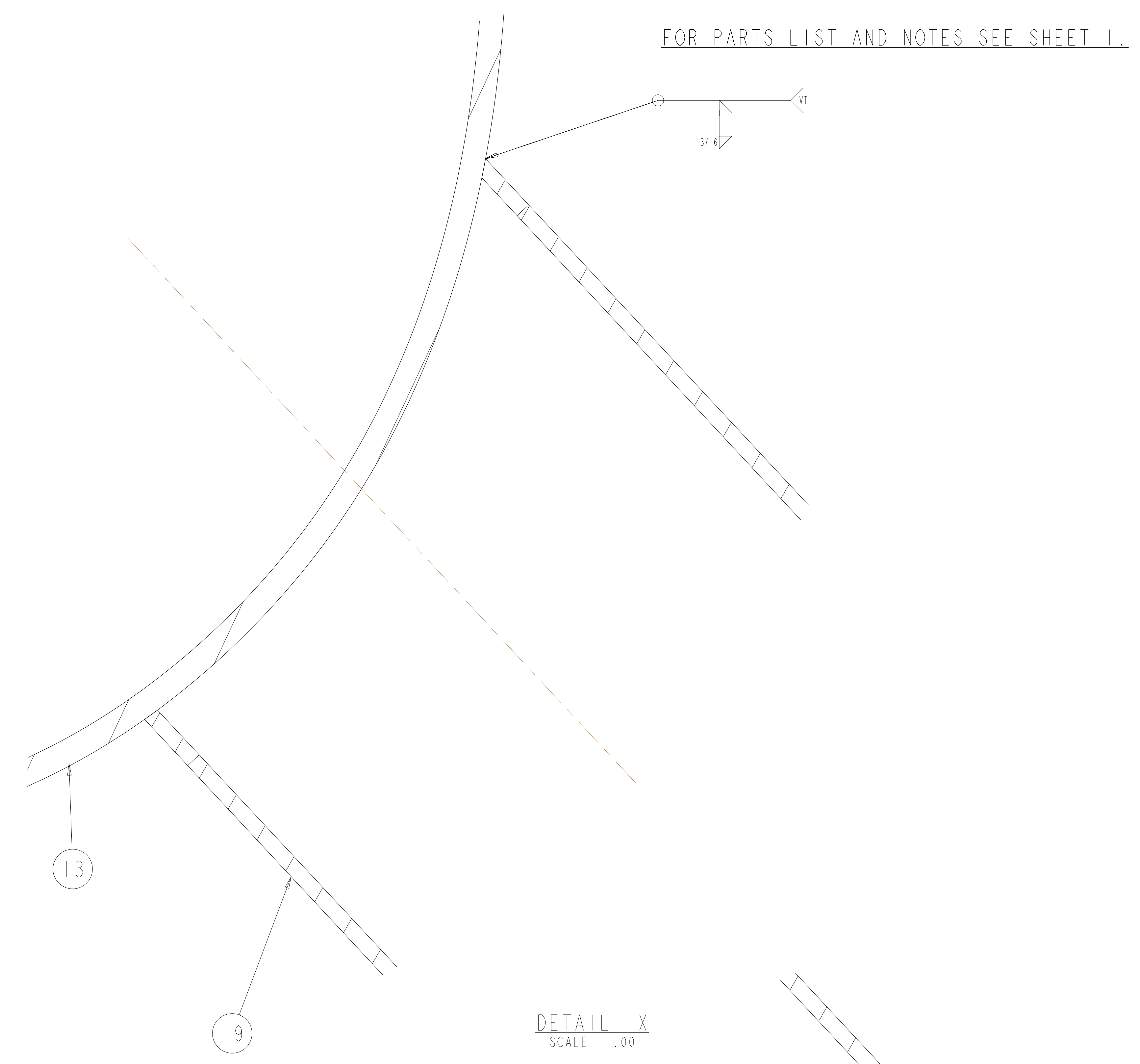

TYPICAL PORT 6A AND 6B SECTION PORT06-PORT06

Rev 2-e: ECN-5021 (RFD-12-017) approved alternate methods for welding the port extensions to the VVSA (See ECN-5021 for details). - Only applicable to VVSA #3 - VVSA #1 and #2 covered by NCR 19464.

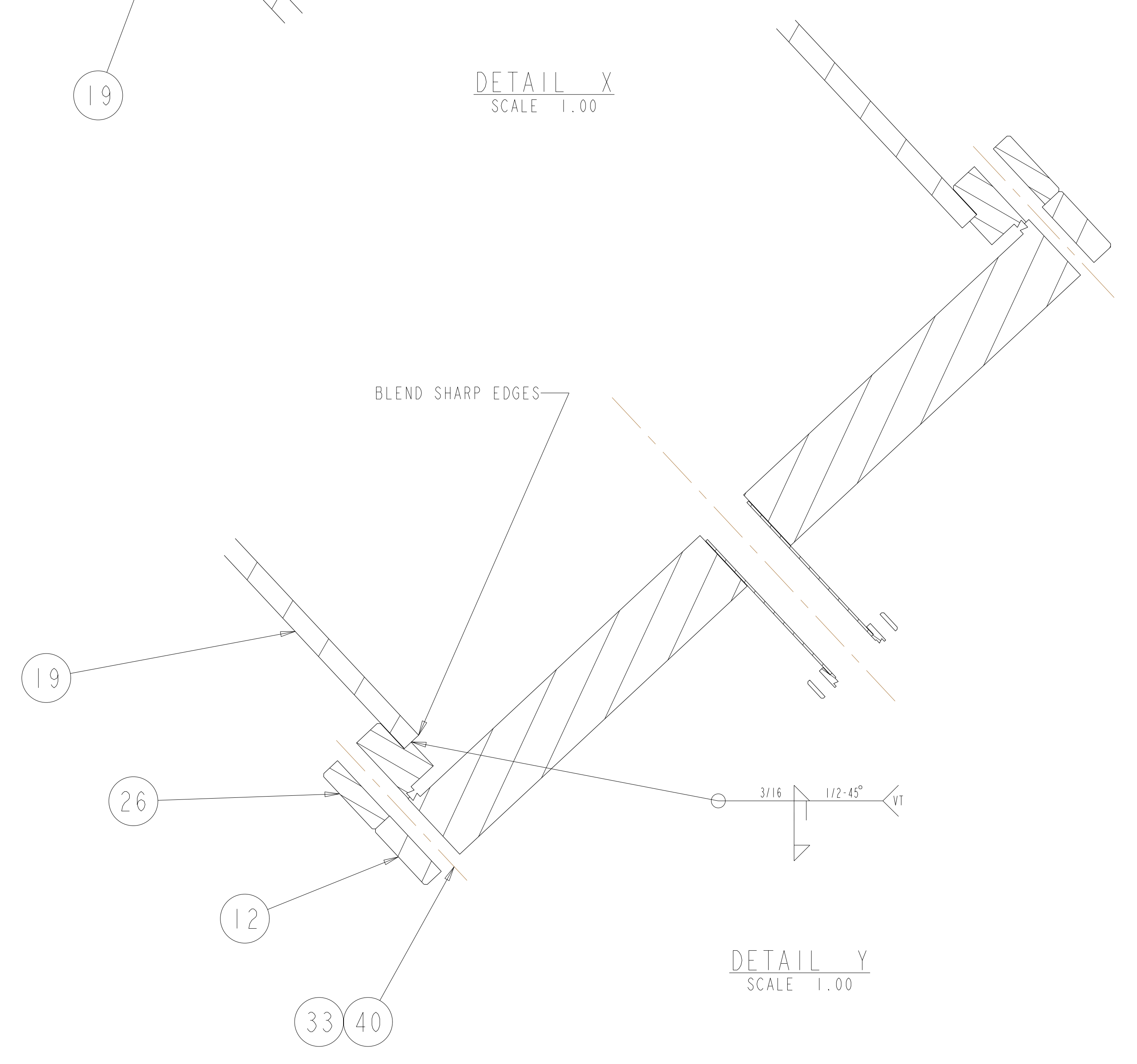

RELEASED FOR FABRICATION / INSTALLATION
 PPPL Drafting:

UT-BATTELLE		Oak Ridge National Laboratory managed for the DEPARTMENT OF ENERGY under U.S. GOVERNMENT contract DE-AC05-00OR22725 UT-BATTELLE, LLC., Oak Ridge, Tennessee	
PROJECT NAME			
NATIONAL COMPACT STELLARATOR EXPERIMENT			
VACUUM VESSEL			
PERIOD INSPECTION AND LEAK CHECK ASSEMBLY			
VERSION NO.	PLANT	BLDG	FL
5	X-10	5700	3
RELEASE LEVEL	SHT OF	TYPE	CLASS
Fabrication	7	A	U
SEI20-004			REV 2

H
G
F
E
D
C
B
A

FOR PARTS LIST AND NOTES SEE SHEET 1.

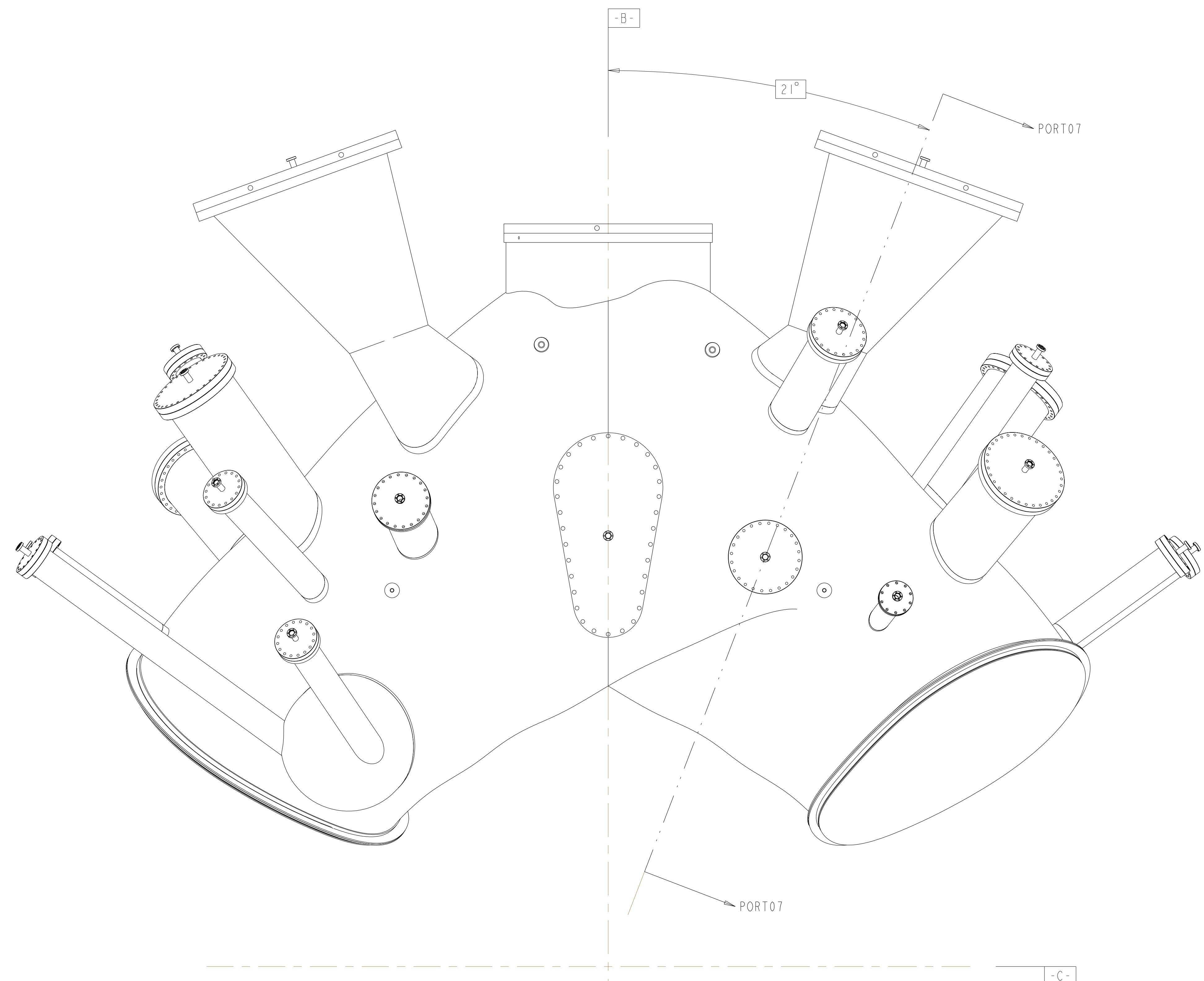

BOTTOM VIEW

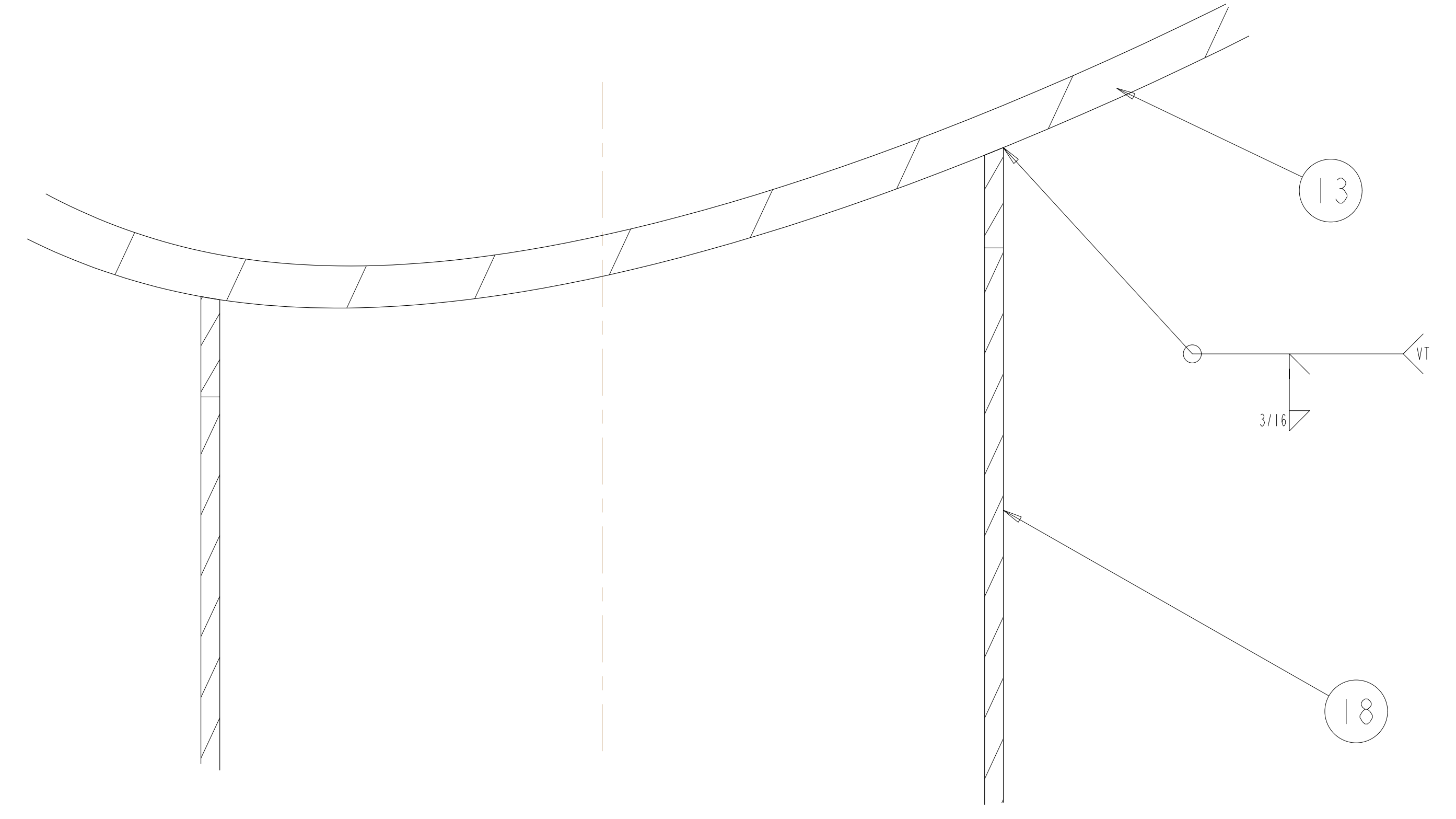

DETAIL X
SCALE 1.00

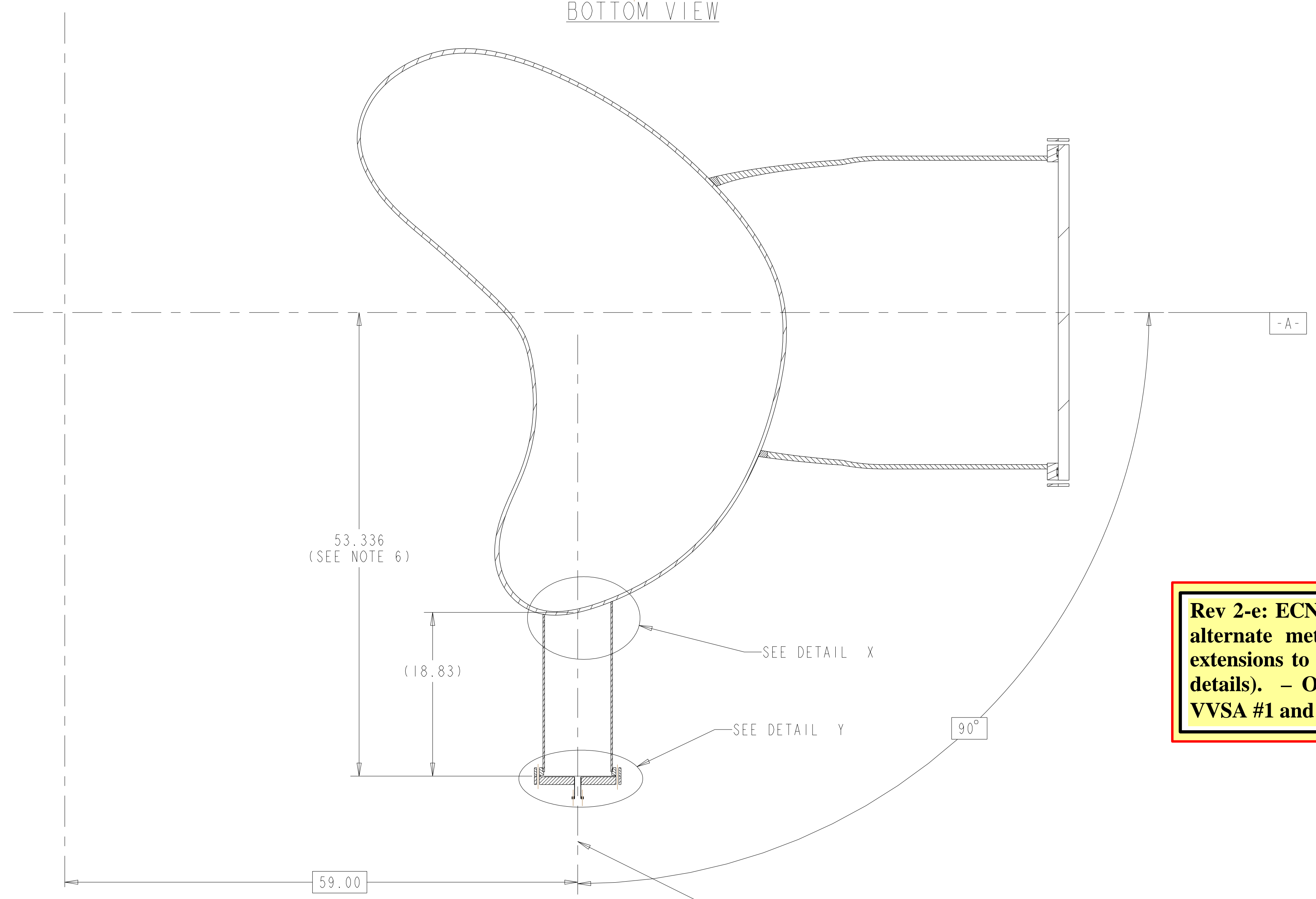

TYPICAL PORT 7A AND 7B
SECTION PORT07-PORT07

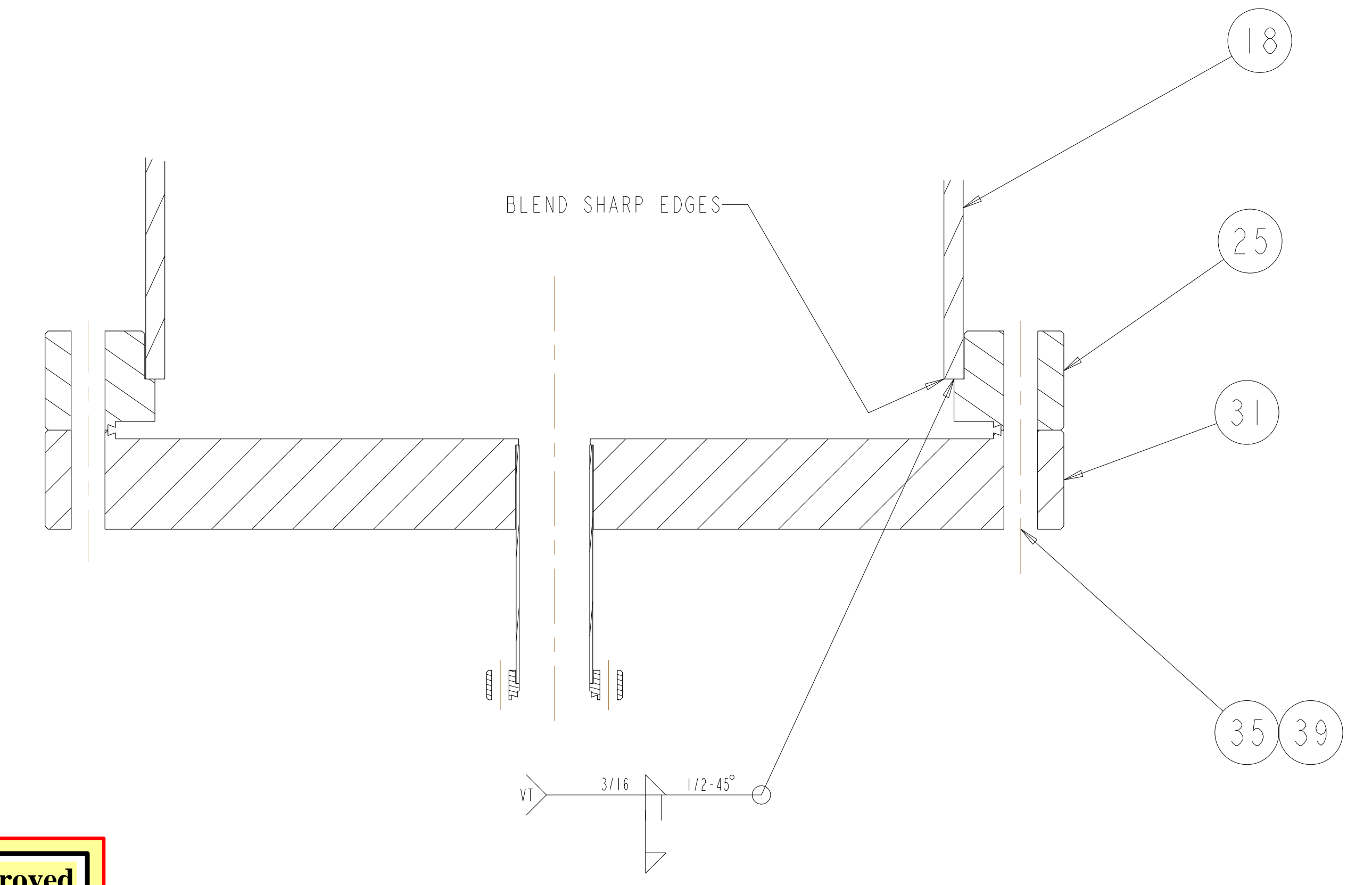

DETAIL Y
SCALE 1.00

Rev 2-e: ECN-5021 (RFD-12-017) approved alternate methods for welding the port extensions to the VVSA (See ECN-5021 for details). - Only applicable to VVSA #3 - VVSA #1 and #2 covered by NCR 19464.

RELEASED FOR FABRICATION / INSTALLATION
 PPPL Drafting:

UT-BATTELLE		Oak Ridge National Laboratory managed for the DEPARTMENT OF ENERGY under U.S. GOVERNMENT contract DE-AC05-00OR22725 UT-BATTELLE, LLC, Oak Ridge, Tennessee	
PROJECT NAME			
NATIONAL COMPACT STELLARATOR EXPERIMENT			
VACUUM VESSEL			
PERIOD INSPECTION AND LEAK CHECK			
ASSEMBLY			
VERSION NO.	PLANT	BLDG	FL
5	X-10	5700	3
RELEASE LEVEL	SHT OF	TYPE	CLASS
Fabrication	8	19	A
SE120-004			REV
			2

H
G
F
E
D
C
B
A

FOR PARTS LIST AND NOTES SEE SHEET 1.

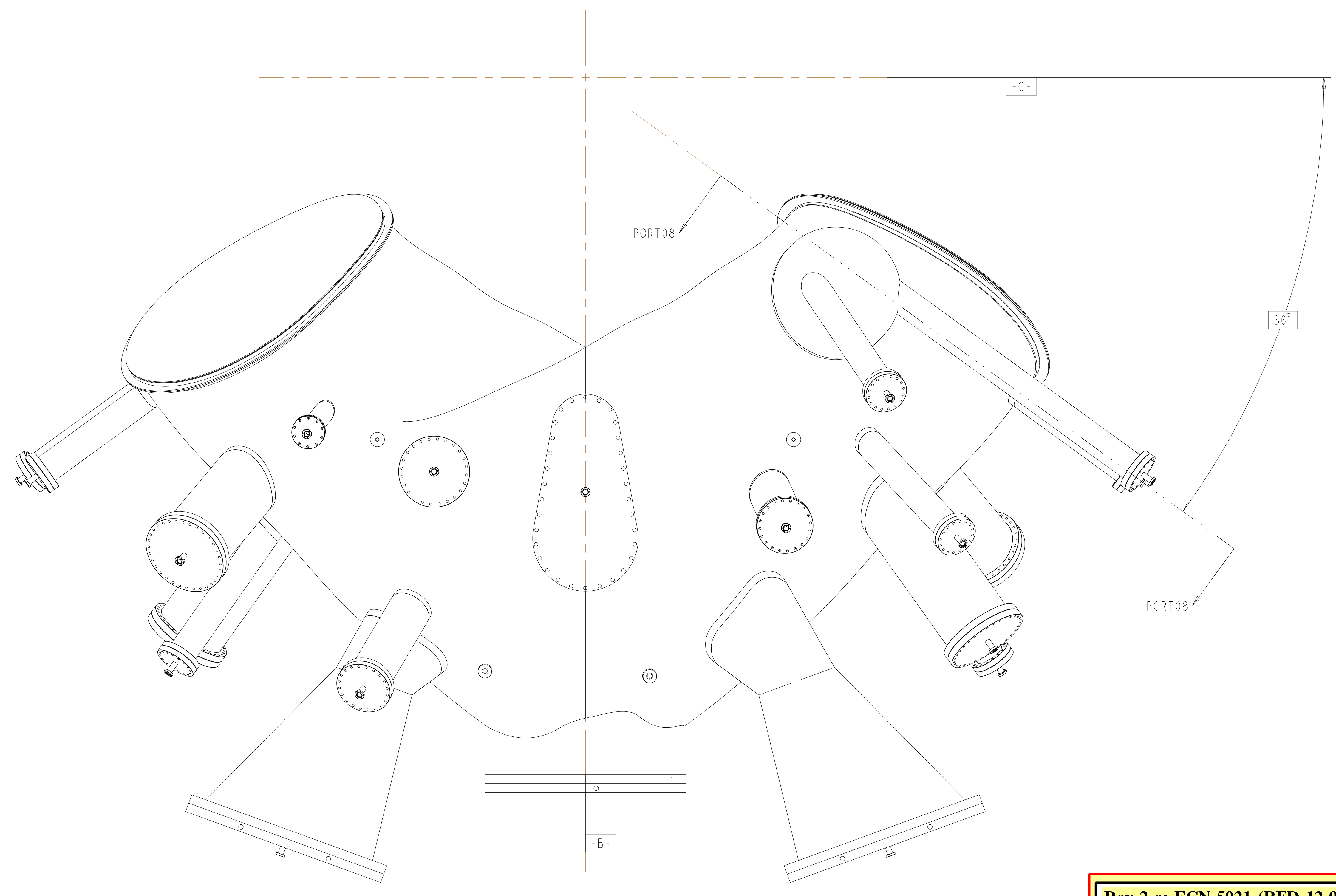

TOP VIEW

Rev 2-e: ECN-5021 (RFD-12-017) approved alternate methods for welding the port extensions to the VVSA (See ECN-5021 for details). - Only applicable to VVSA #3 - VVSA #1 and #2 covered by NCR 19464.

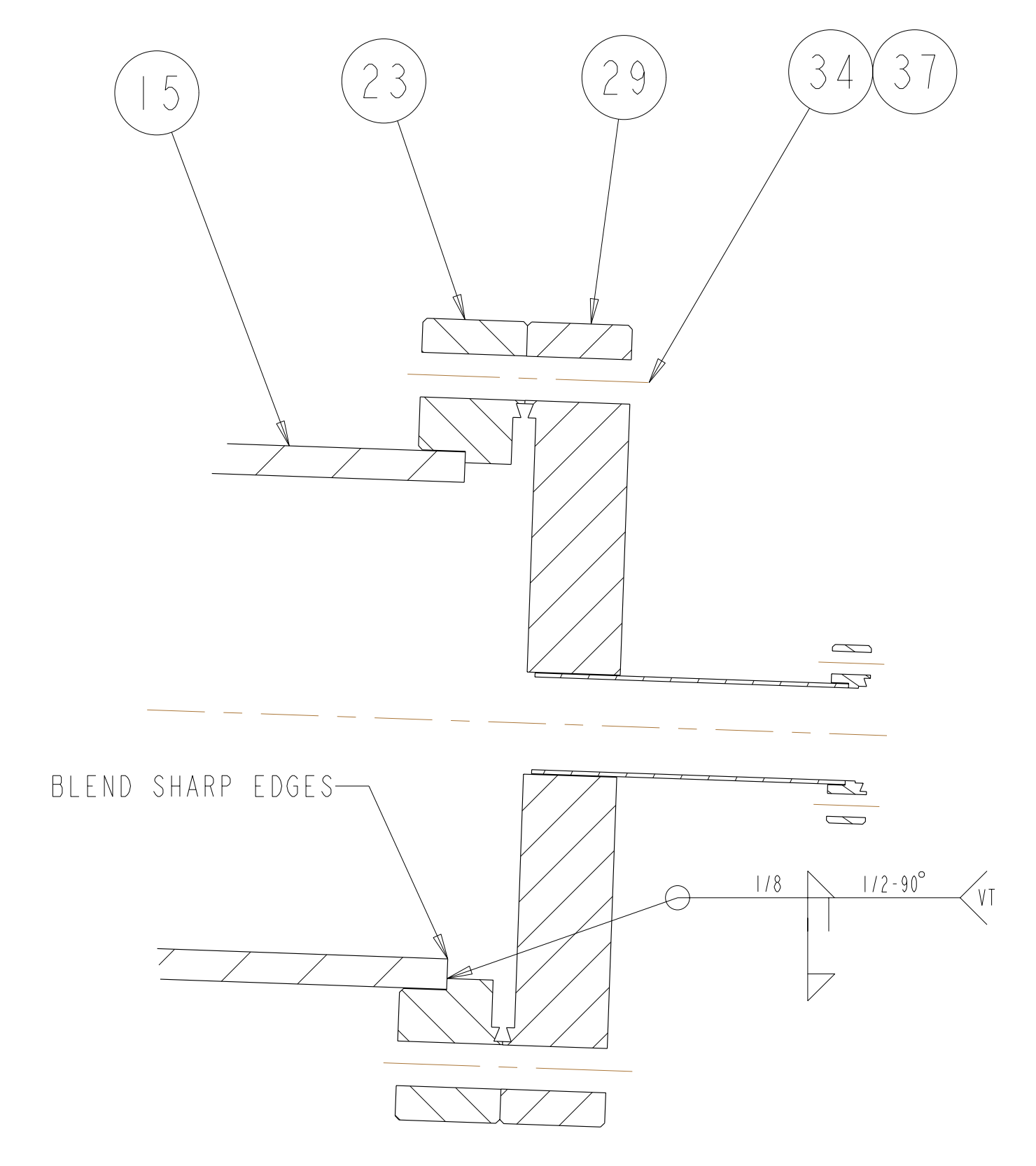

DETAIL Y
SCALE 1.00

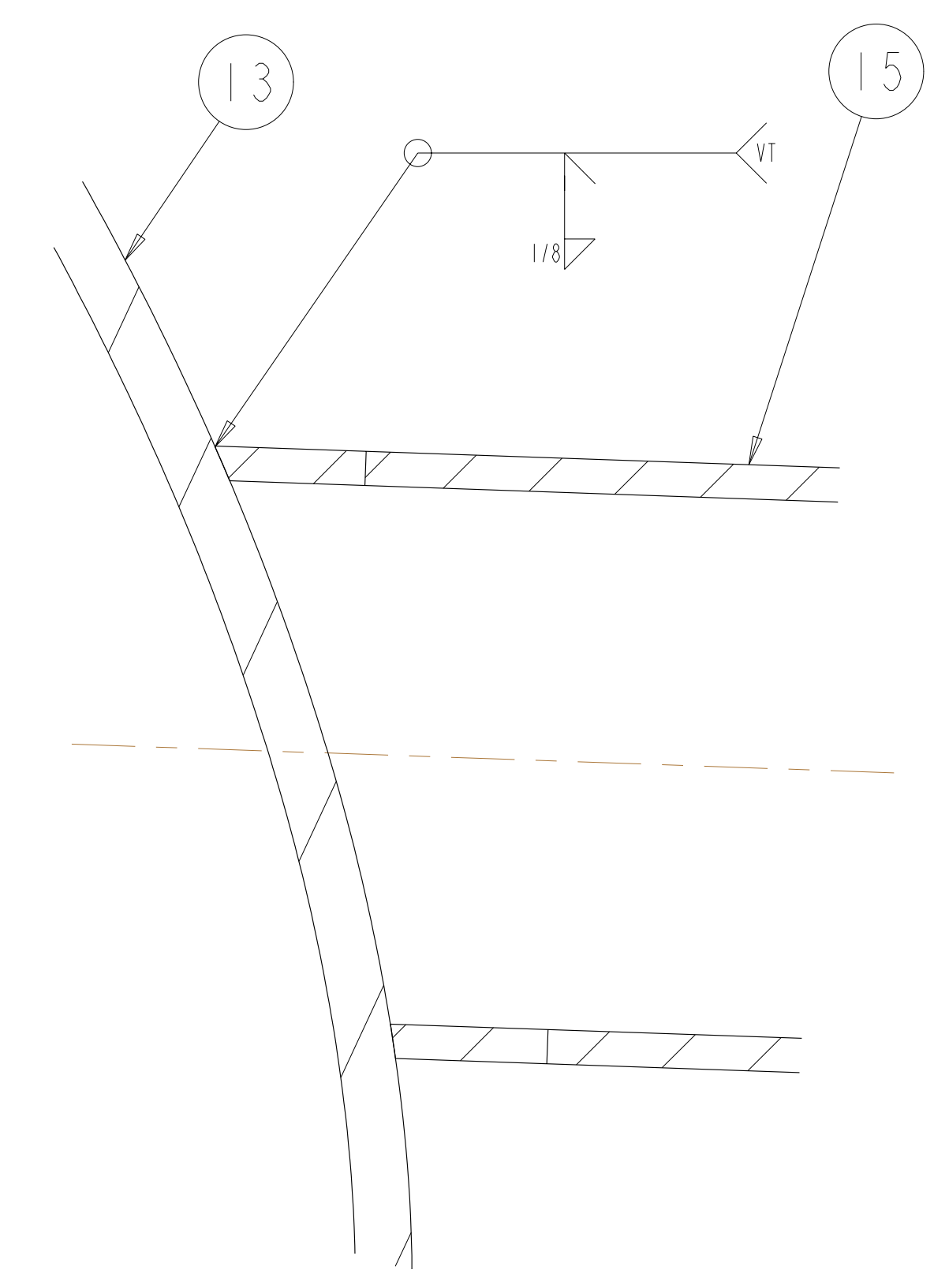

DETAIL X
SCALE 1.00

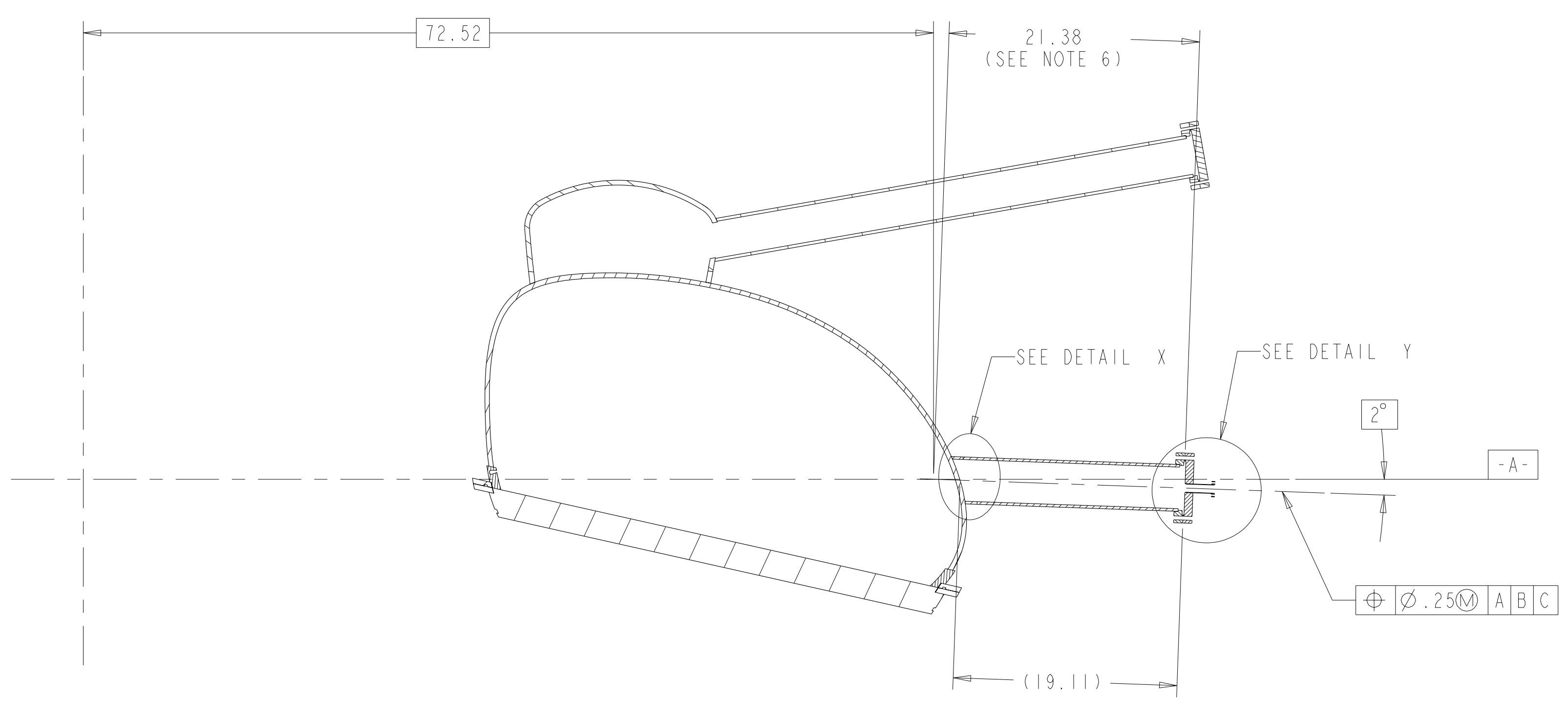

TYPICAL PORT 8A AND 8B
SECTION PORT08-PORT08

**RELEASED FOR
FABRICATION / INSTALLATION**
PPPL Drafting:

UT-BATTELLE		Oak Ridge National Laboratory managed for the DEPARTMENT OF ENERGY under U.S. GOVERNMENT contract DE-AC05-00OR22725 UT-BATTELLE, LLC, Oak Ridge, Tennessee	
PROJECT NAME			
NATIONAL COMPACT STELLERATOR EXPERIMENT			
VACUUM VESSEL			
PERIOD INSPECTION AND LEAK CHECK			
ASSEMBLY			
VERSION NO.	PLANT	BLDG	FL
5	X-10	5700	3
RELEASE LEVEL	SHT OF	TYPE	CLASS
Fabrication	19	A	U
SE120-004			REV
			2

SE120-004

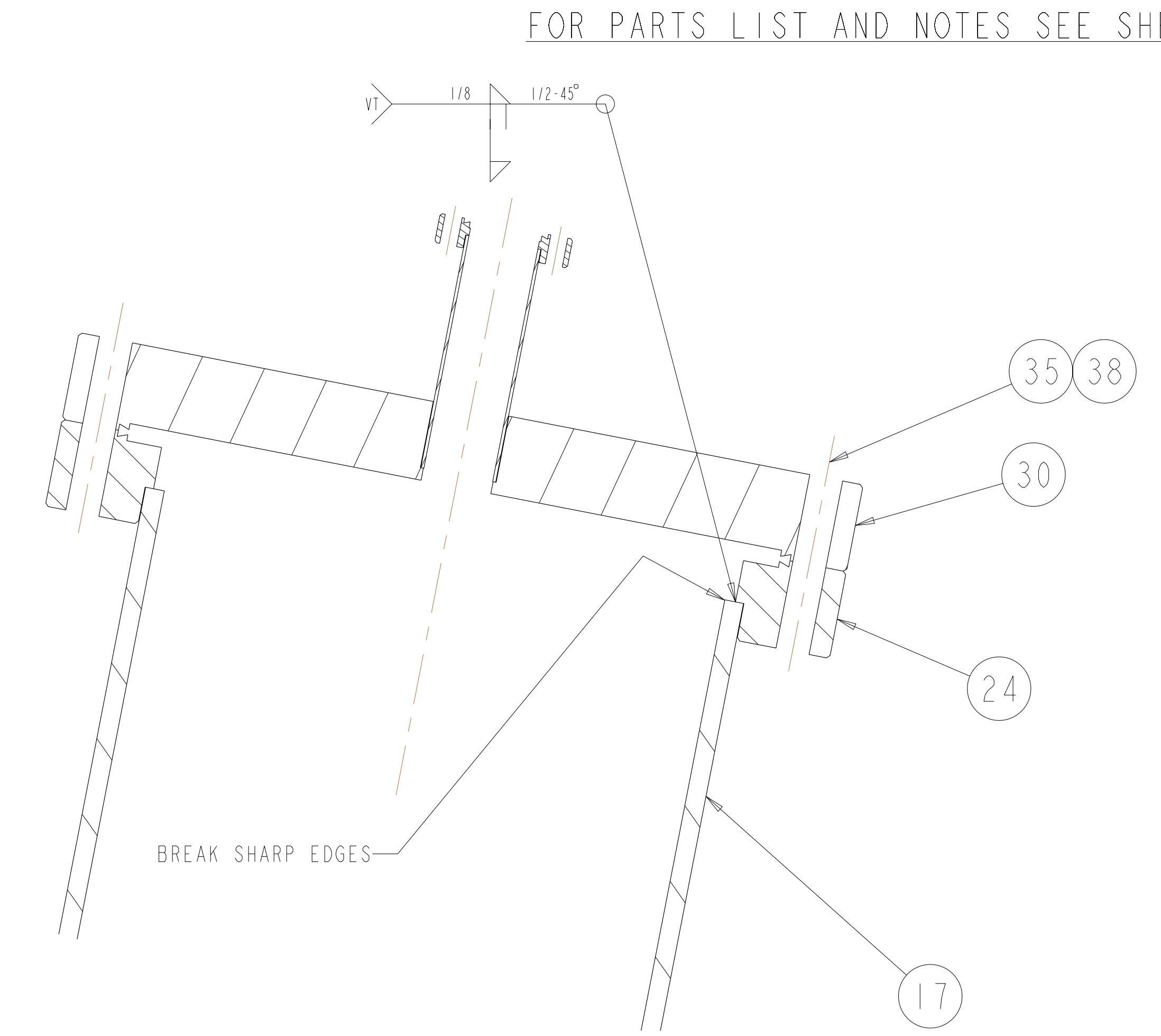
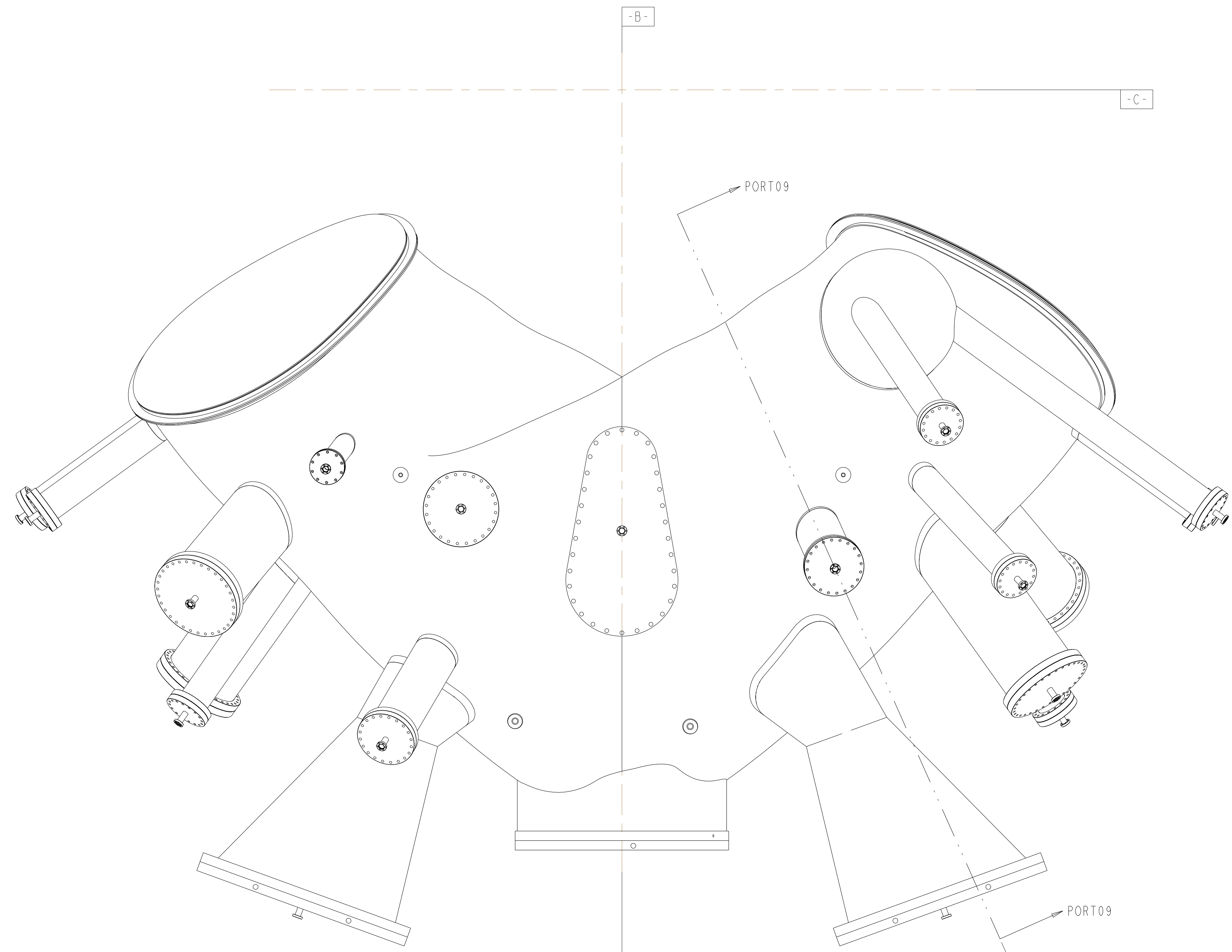

DETAIL Y
 SCALE 1.00

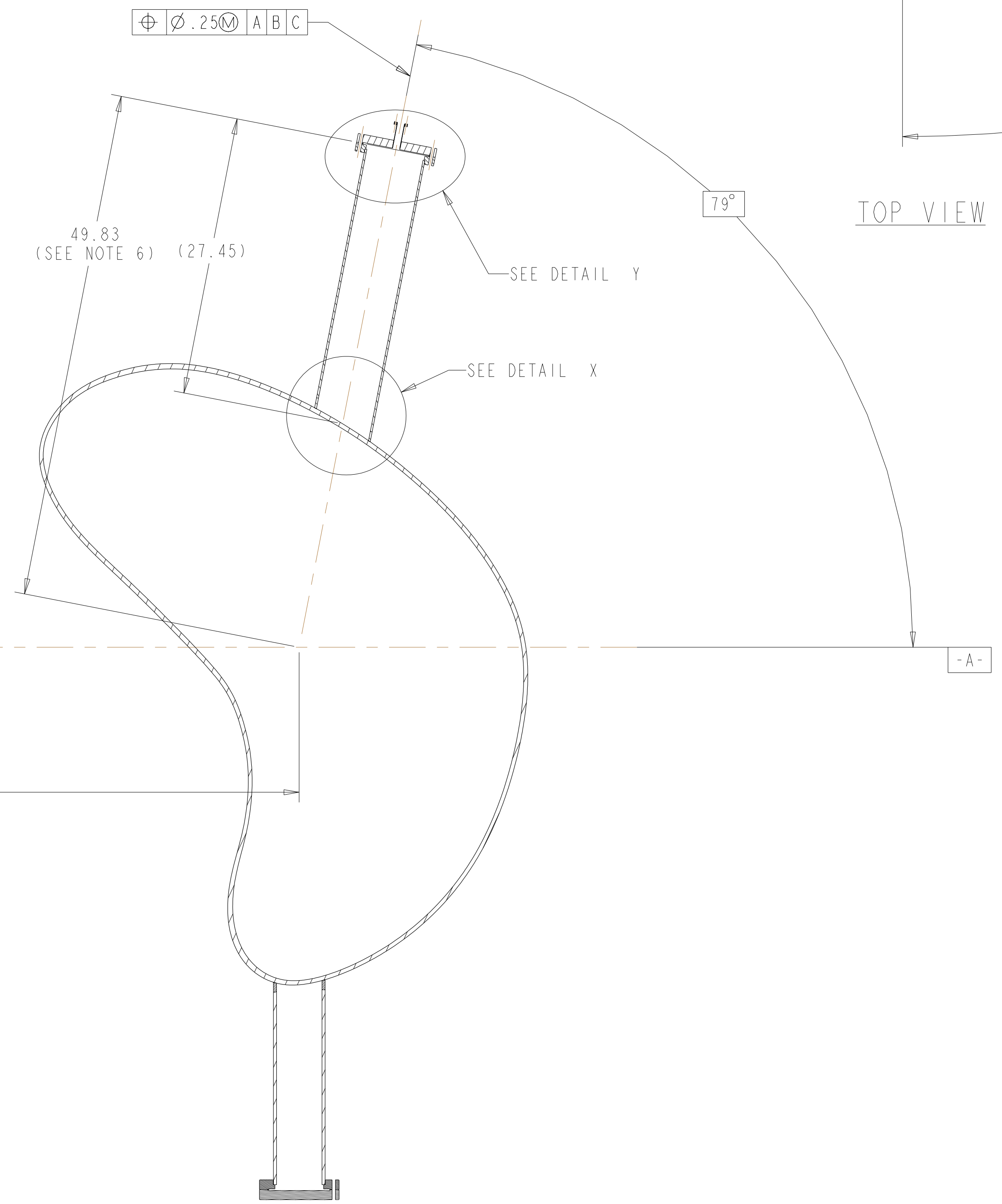

TOP VIEW

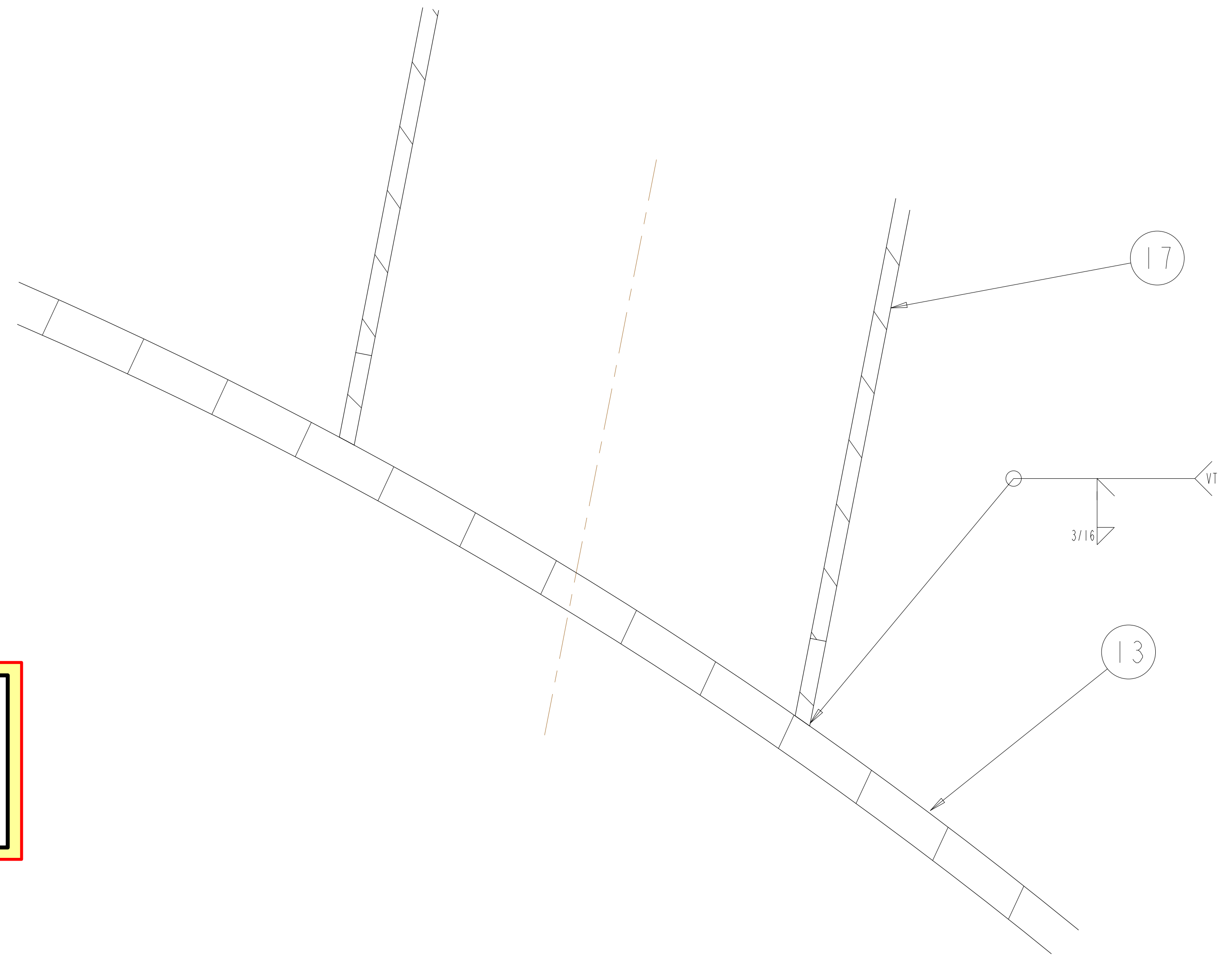

DETAIL X
 SCALE 1.00

Rev 2-e: ECN-5021 (RFD-12-017) approved alternate methods for welding the port extensions to the VVSA (See ECN-5021 for details). - Only applicable to VVSA #3 - VVSA #1 and #2 covered by NCR 19464.

RELEASED FOR FABRICATION / INSTALLATION
 PPPL Drafting:

TYPICAL PORT 9A AND 9B
 SECTION PORT09-PORT09

UT-BATTELLE		Oak Ridge National Laboratory managed for the DEPARTMENT OF ENERGY under U.S. GOVERNMENT contract DE-AC05-00OR22725 UT-BATTELLE, LLC, Oak Ridge, Tennessee					
NATIONAL COMPACT STELLARATOR EXPERIMENT							
VACUUM VESSEL PERIOD INSPECTION AND LEAK CHECK ASSEMBLY							
VERSION NO.	PLANT	BLDG	FL	SHT OF	TYPE	CLASS	
5	X-10	5700	3	10	19	A	
RELEASE LEVEL	SE120-004						REV
Fabrication							2

H
G
F
E
D
C
B
A

FOR PARTS LIST AND NOTES SEE SHEET 1.

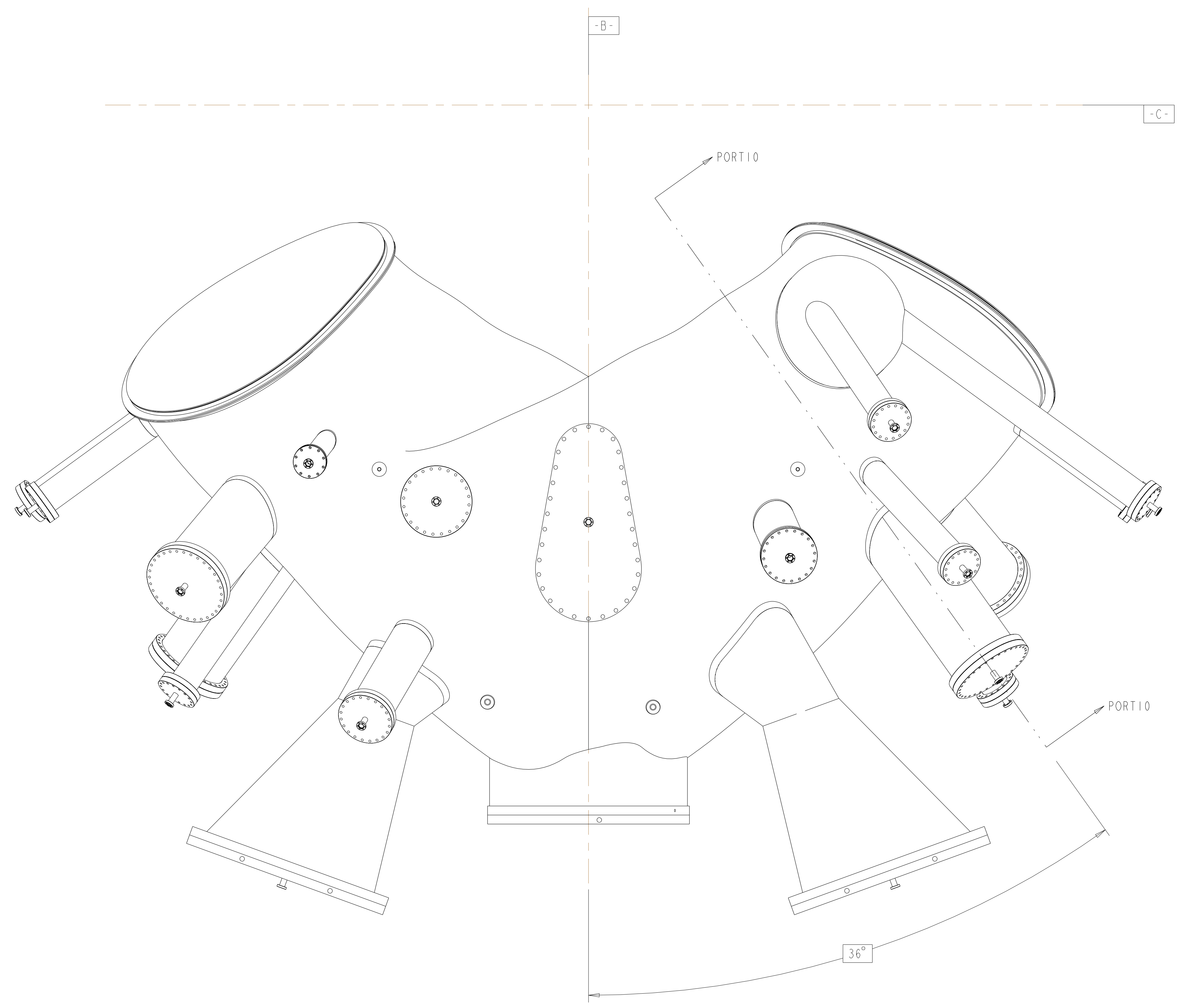

TOP VIEW

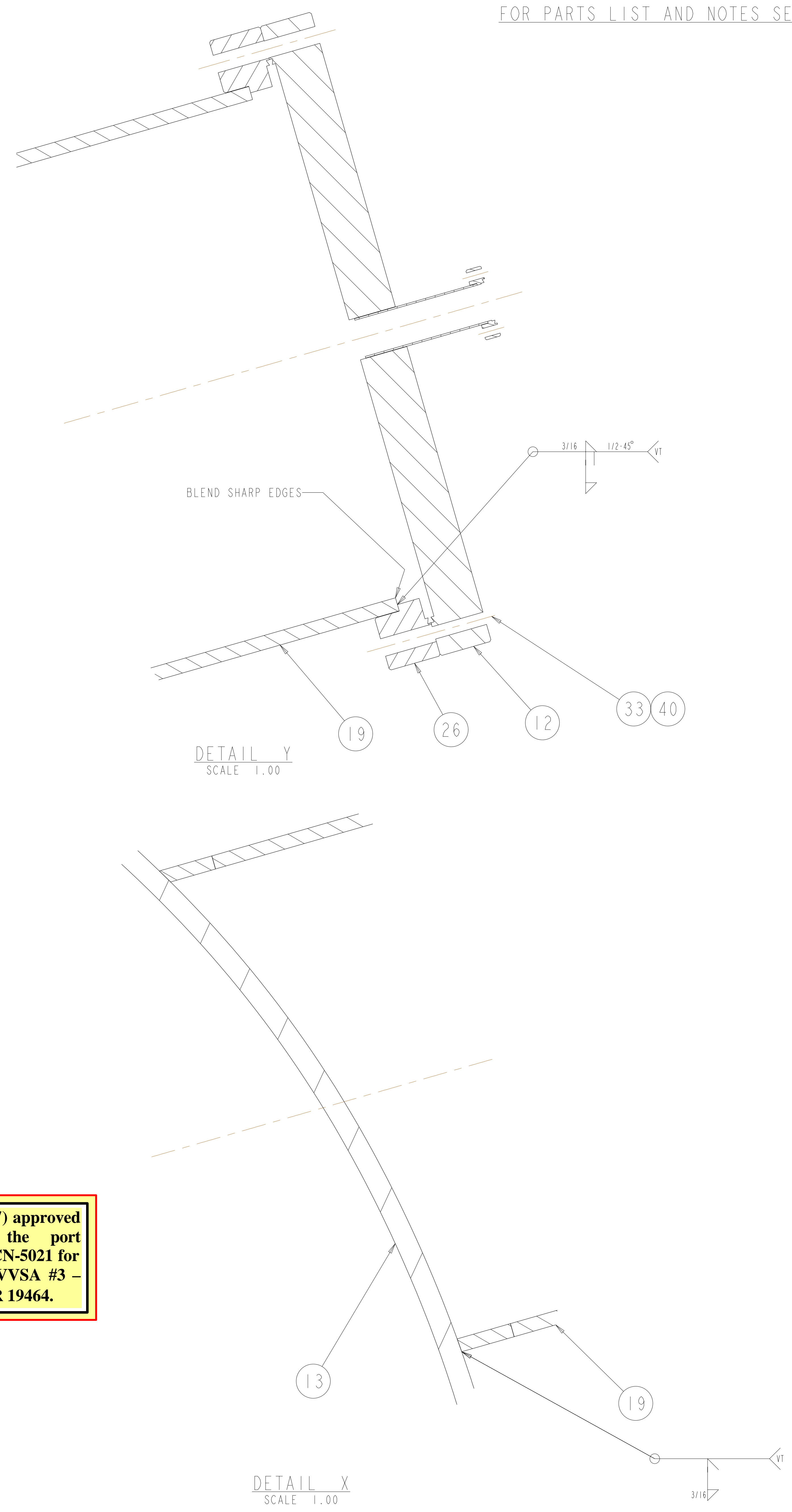

DETAIL Y
SCALE 1.00

DETAIL X
SCALE 1.00

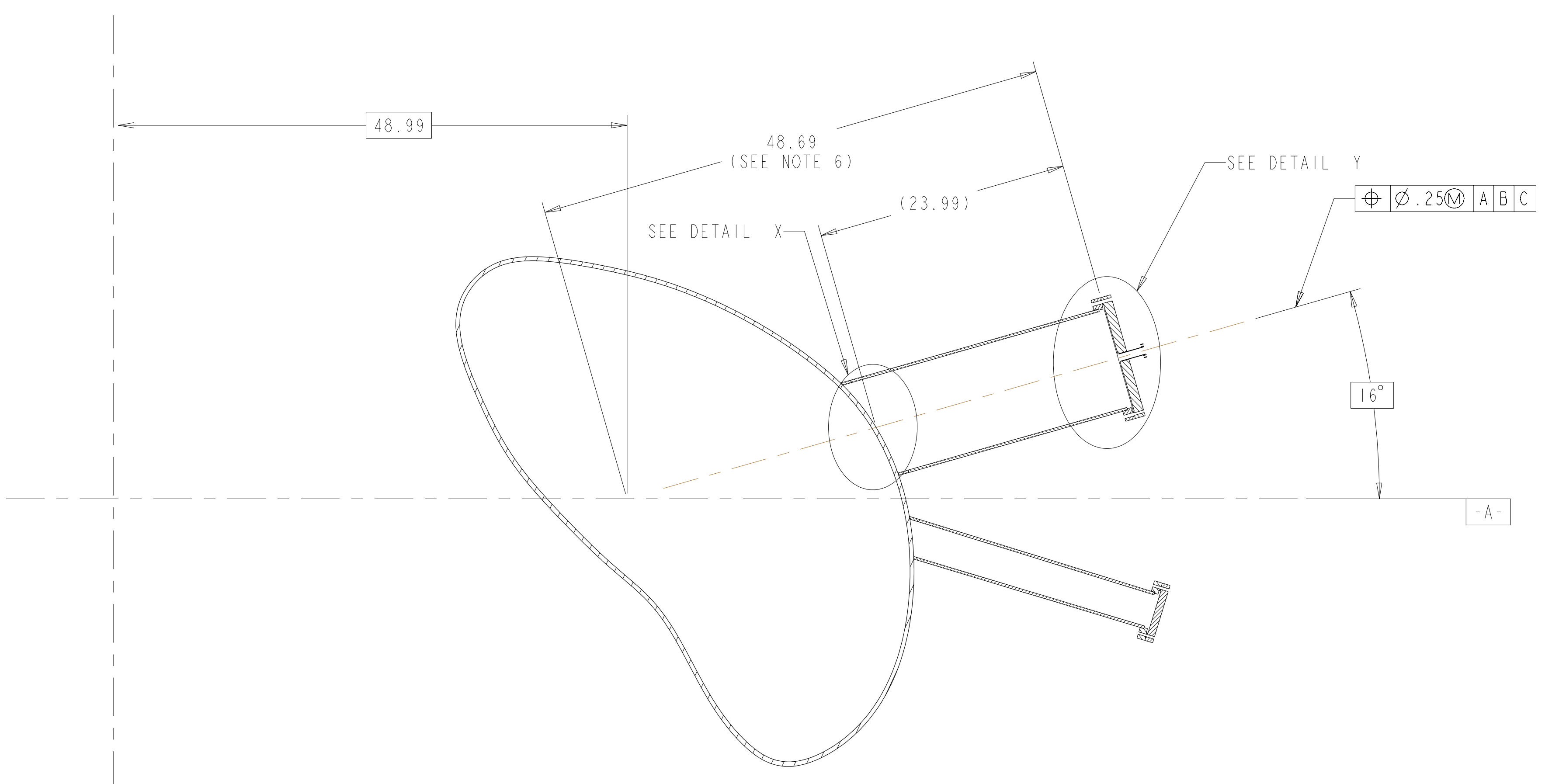

TYPICAL PORT 10A AND 10B
SECTION PORT10-PORT10

Rev 2-e: ECN-5021 (RFD-12-017) approved alternate methods for welding the port extensions to the VVSA (See ECN-5021 for details). - Only applicable to VVSA #3 - VVSA #1 and #2 covered by NCR 19464.

**RELEASED FOR
FABRICATION / INSTALLATION**
PPPL Drafting:

UT-BATTELLE		Oak Ridge National Laboratory managed for the DEPARTMENT OF ENERGY under U.S. GOVERNMENT contract DE-AC05-00OR22725 UT-BATTELLE, LLC, Oak Ridge, Tennessee	
PROJECT NAME			
NATIONAL COMPACT STELLARATOR EXPERIMENT			
VACUUM VESSEL			
PERIOD INSPECTION AND LEAK CHECK			
ASSEMBLY			
VERSION NO.	PLANT	BLDG	FL
5	X-10	5700	3
RELEASE LEVEL	SHT OF	TYPE	CLASS
Fabrication	11	19	A
SE120-004			REV
			2

H
G
F
E
D
C
B
A

SE120-004

FOR PARTS LIST AND NOTES SEE SHEET 1.

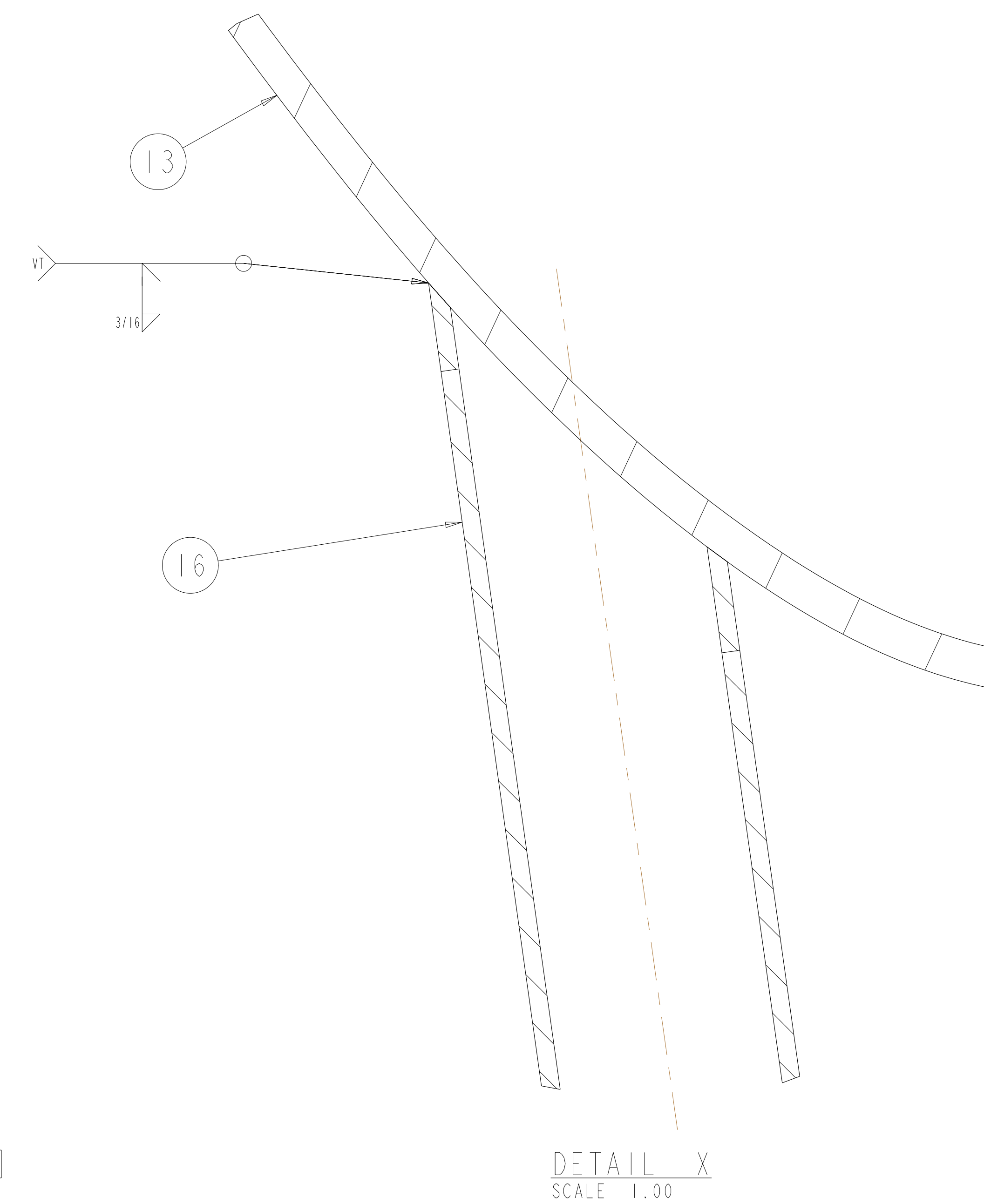
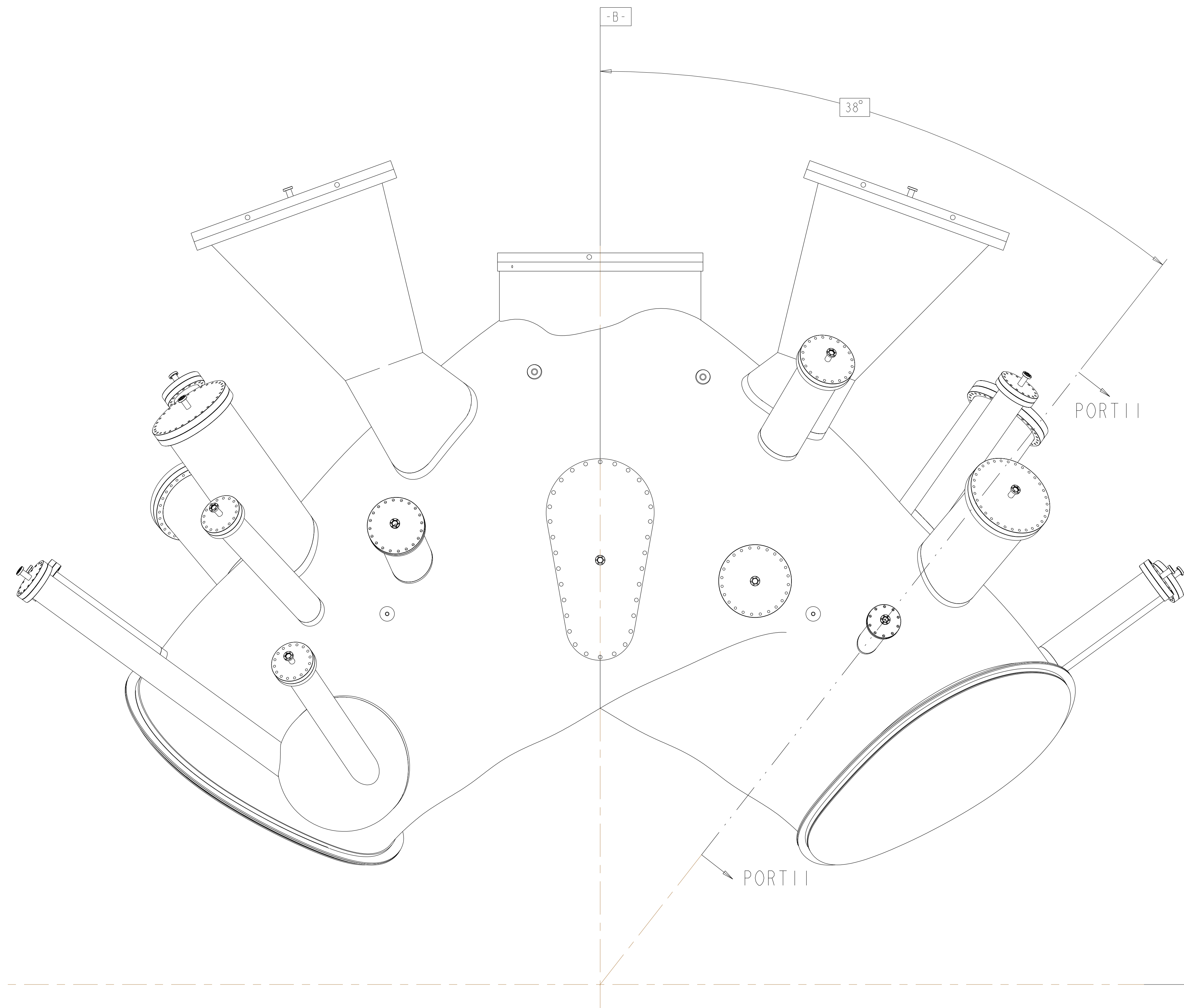

BOTTOM VIEW

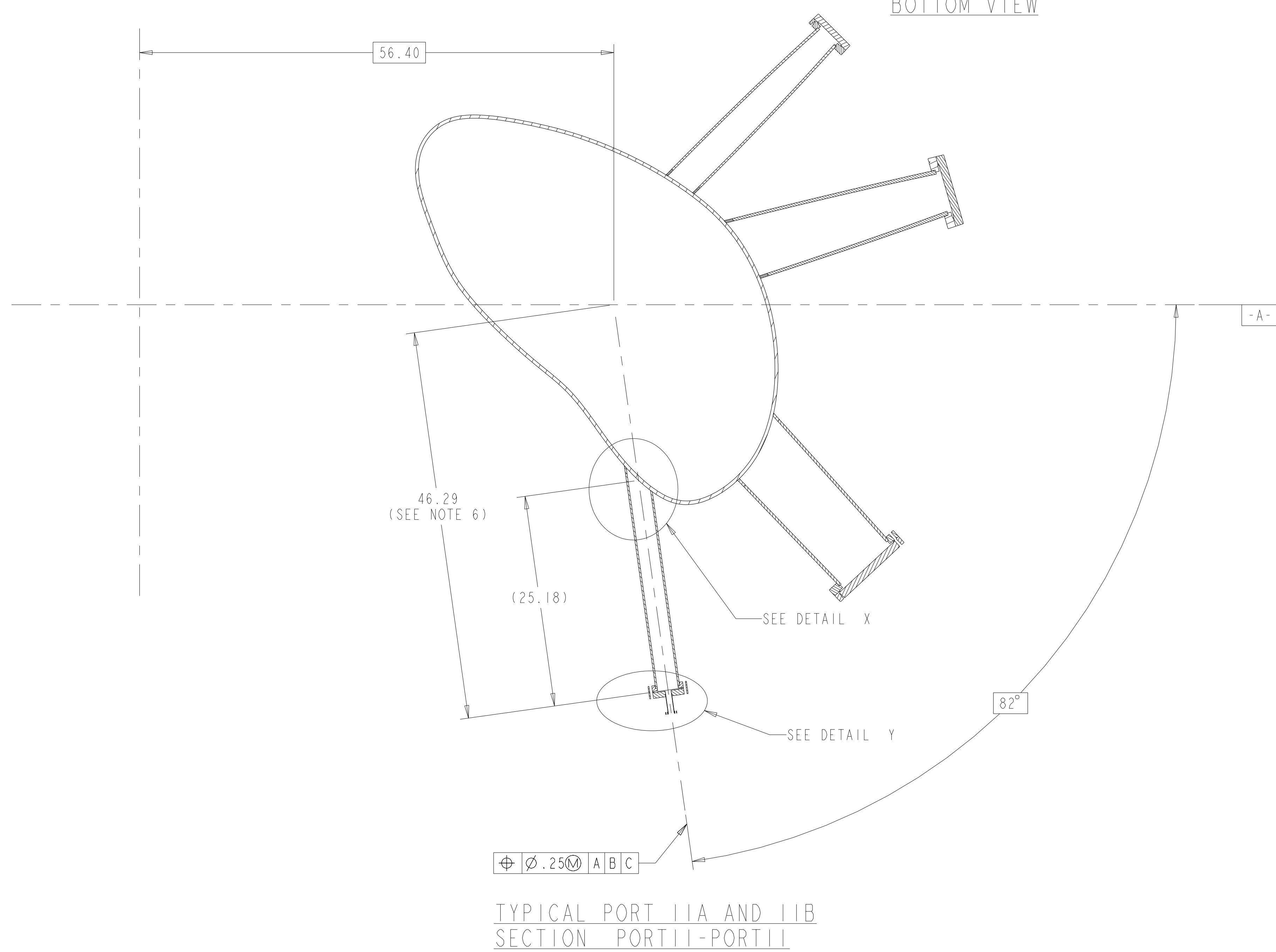

Rev 2-e: ECN-5021 (RFD-12-017) approved alternate methods for welding the port extensions to the VVSA (See ECN-5021 for details). - Only applicable to VVSA #3 - VVSA #1 and #2 covered by NCR 19464.

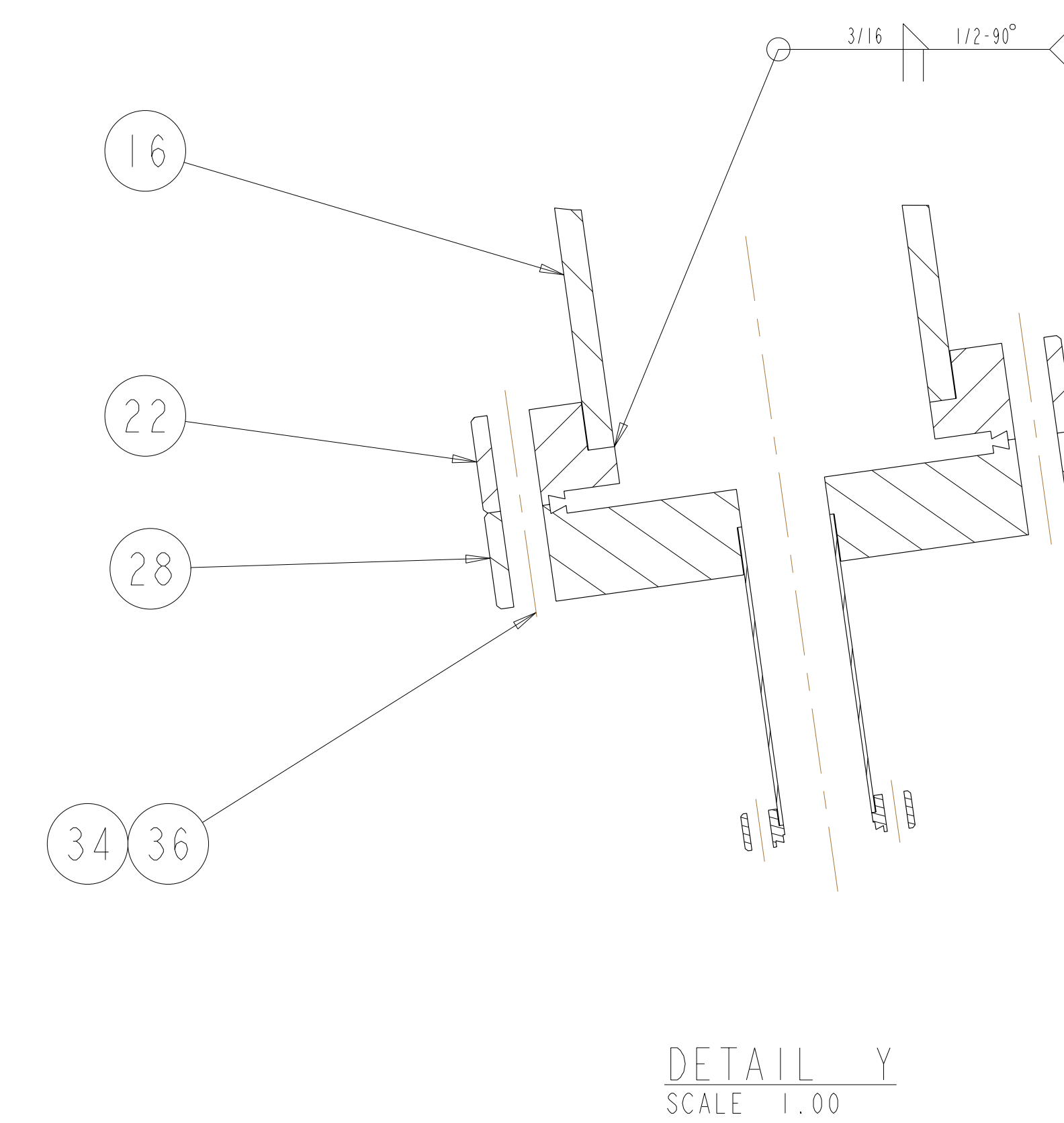

RELEASED FOR FABRICATION / INSTALLATION
PPPL Drafting:

UT-BATTELLE							Oak Ridge National Laboratory managed for the DEPARTMENT OF ENERGY under U.S. GOVERNMENT contract DE-AC05-00OR22725 UT-BATTELLE, LLC., Oak Ridge, Tennessee	
NATIONAL COMPACT STELLARATOR EXPERIMENT							PROJECT NAME	
VACUUM VESSEL PERIOD INSPECTION AND LEAK CHECK ASSEMBLY							CLASS	
VERSION NO.	PLANT	BLDG	FL	SHT OF	TYPE	CLASS	REV	
5	X-10	5700	3	12	19	A	U	
RELEASE LEVEL Fabrication							SE120-004	
							2	

H
G
F
E
D
C
B
A

SE120-004

FOR PARTS LIST AND NOTES SEE SHEET 1.

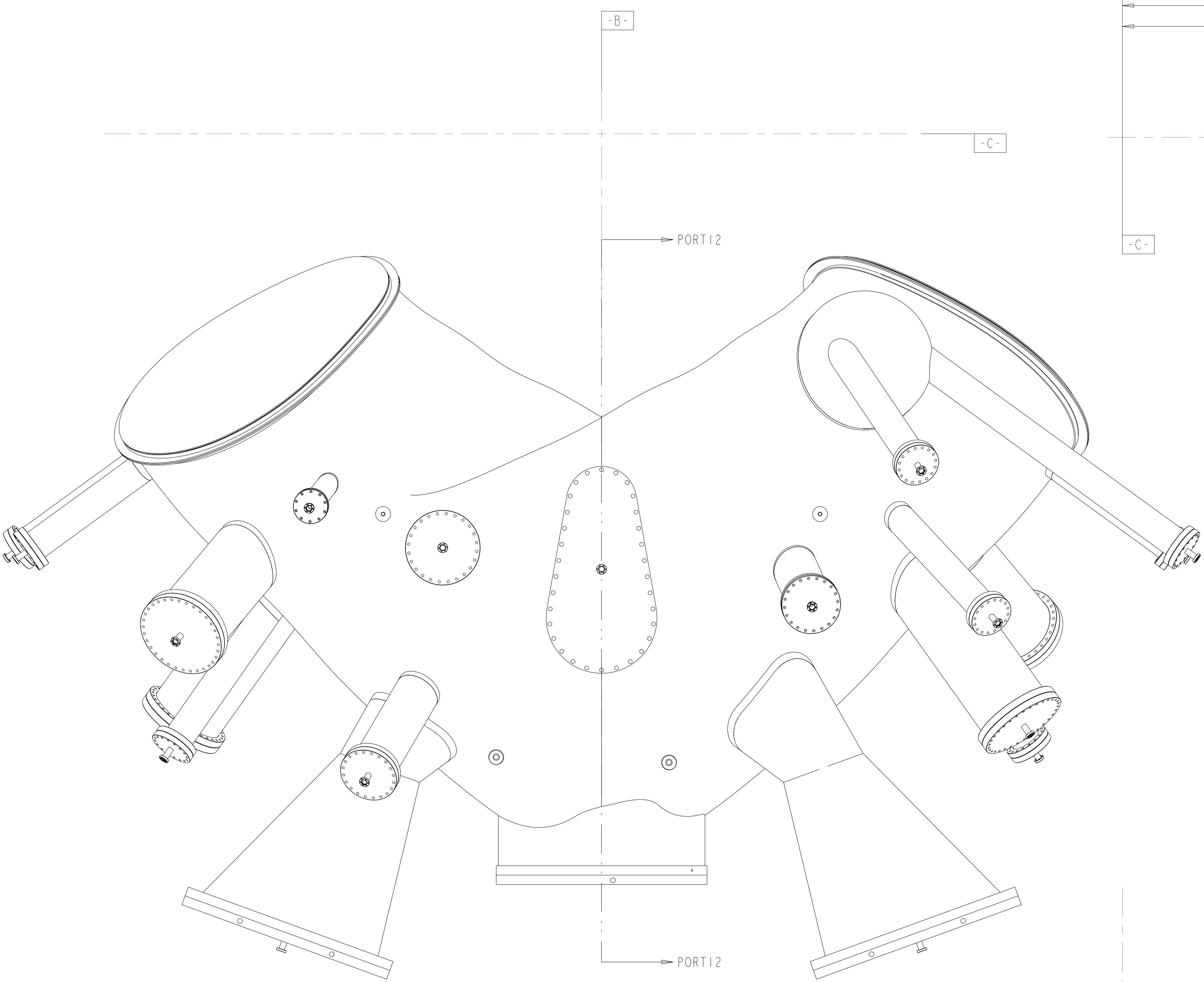

TOP VIEW

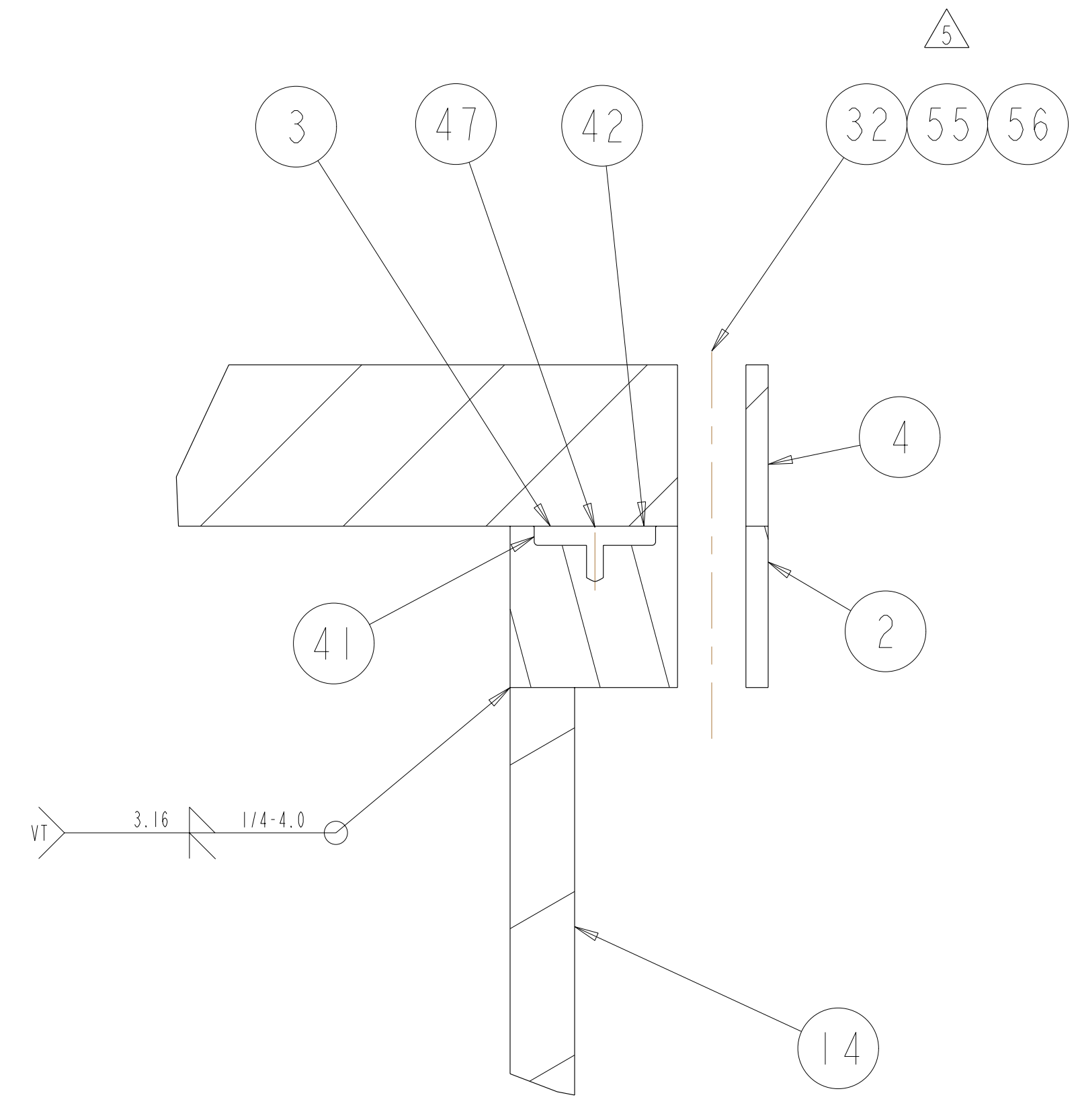
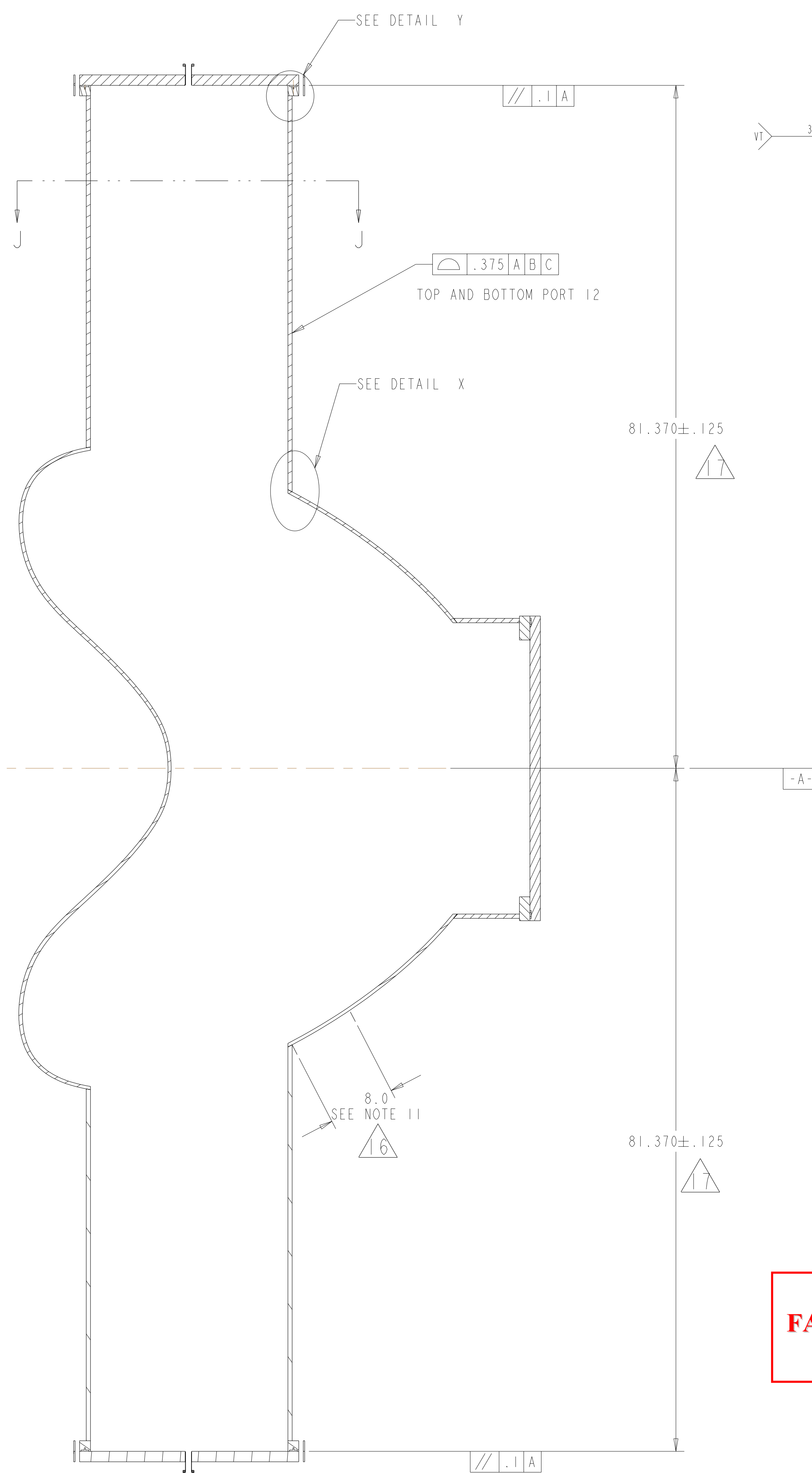
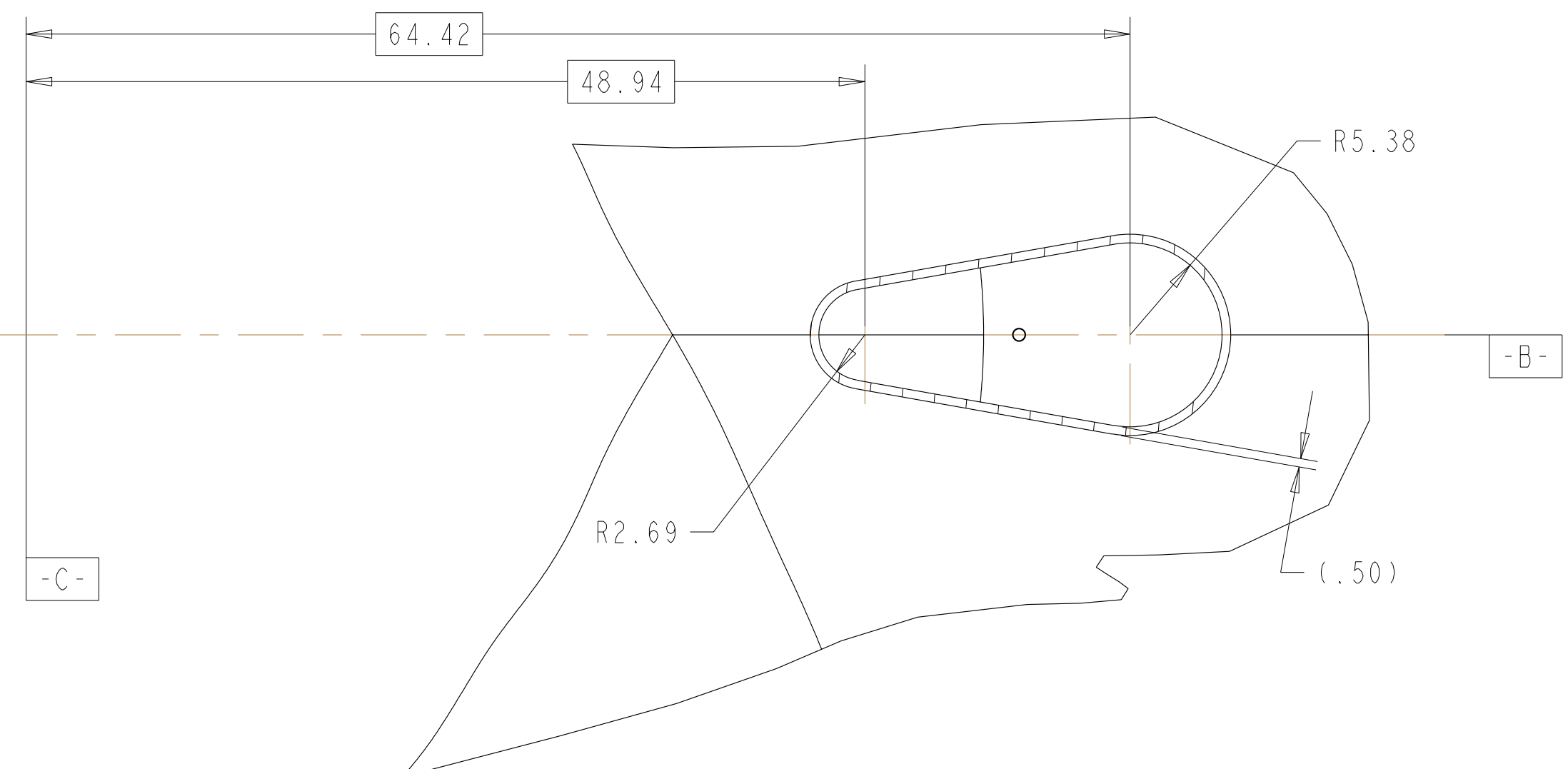

DETAIL Y
 SCALE 1.00

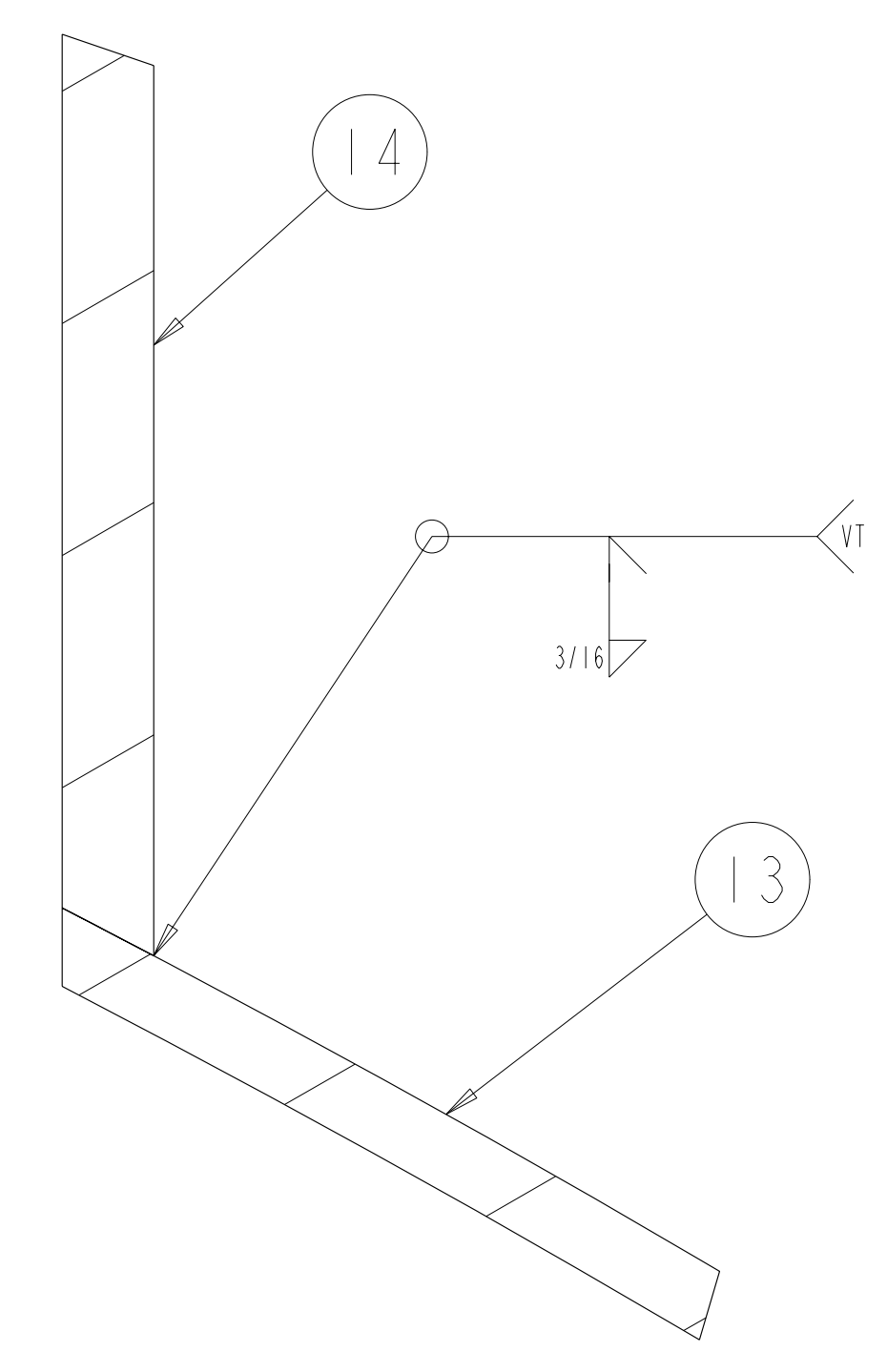

DETAIL X
 SCALE 1.00

Rev 2-e: ECN-5021 (RFD-12-017) approved alternate methods for welding the port extensions to the VVSA (See ECN-5021 for details). - Only applicable to VVSA #3 - VVSA #1 and #2 covered by NCR 19464.

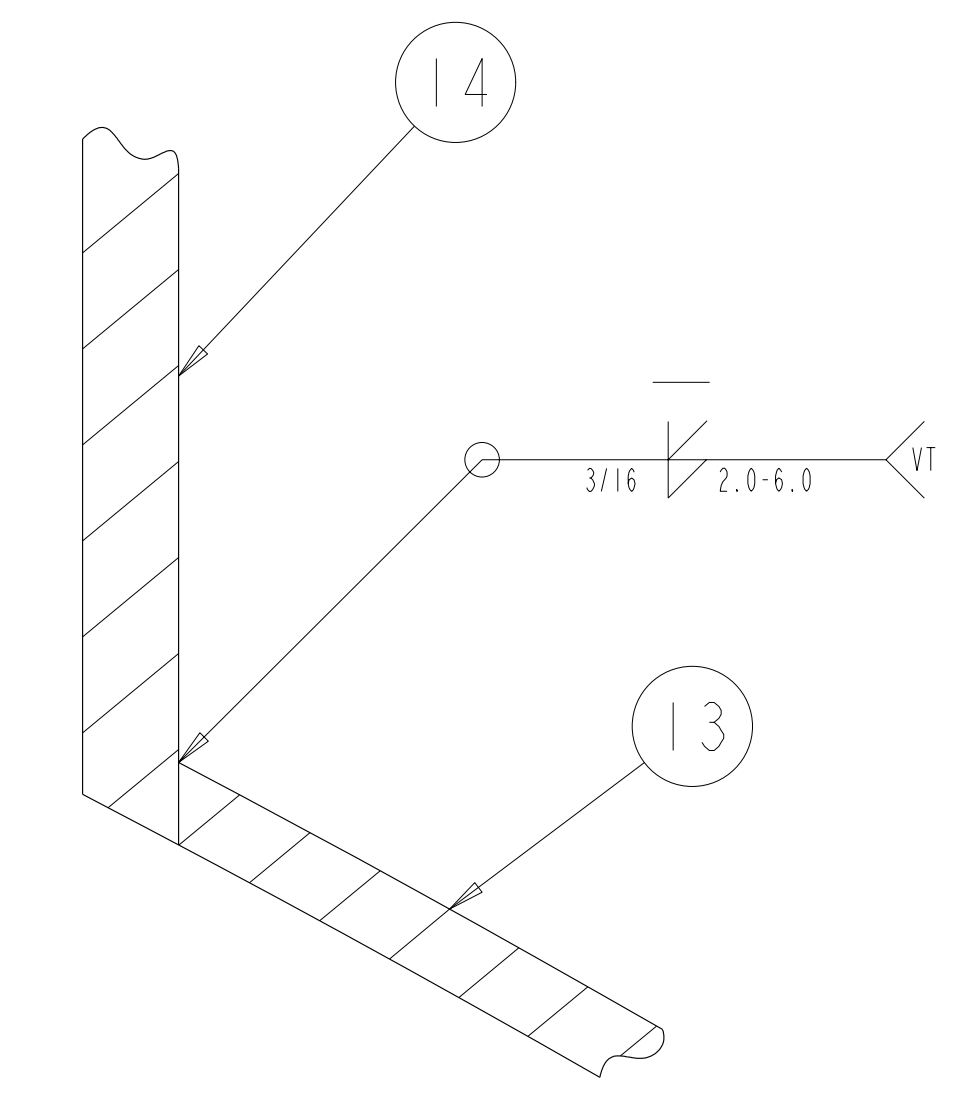

OPTIONAL WELD DETAIL

RELEASED FOR FABRICATION / INSTALLATION
 PPPL Drafting:

UT-BATTELLE		Oak Ridge National Laboratory managed for the DEPARTMENT OF ENERGY under U.S. GOVERNMENT contract DE-AC05-00OR22725 UT-BATTELLE, LLC, Oak Ridge, Tennessee	
NATIONAL COMPACT STELLARATOR EXPERIMENT			
VACUUM VESSEL PERIOD INSPECTION AND LEAK CHECK ASSEMBLY			
VERSION NO. 5	PLANT X-10	BLDG 5700	FL SHT OF TYPE CLASS 3 13 19 A U
RELEASE LEVEL Fabrication	SE120-004		REV 2

H
G
F
E
D
C
B
A

FOR PARTS LIST AND NOTES SEE SHEET 1.

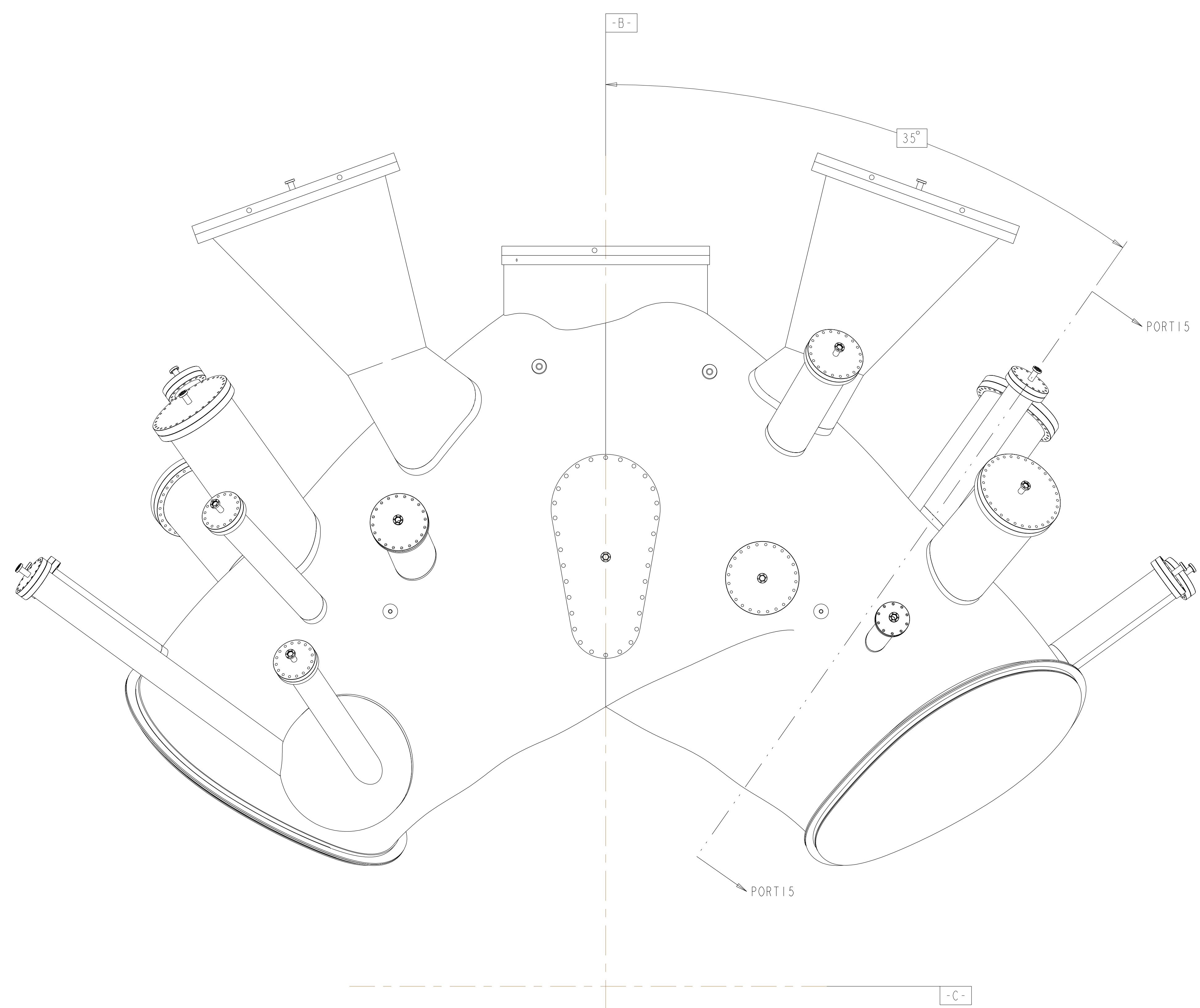

BOTTOM VIEW

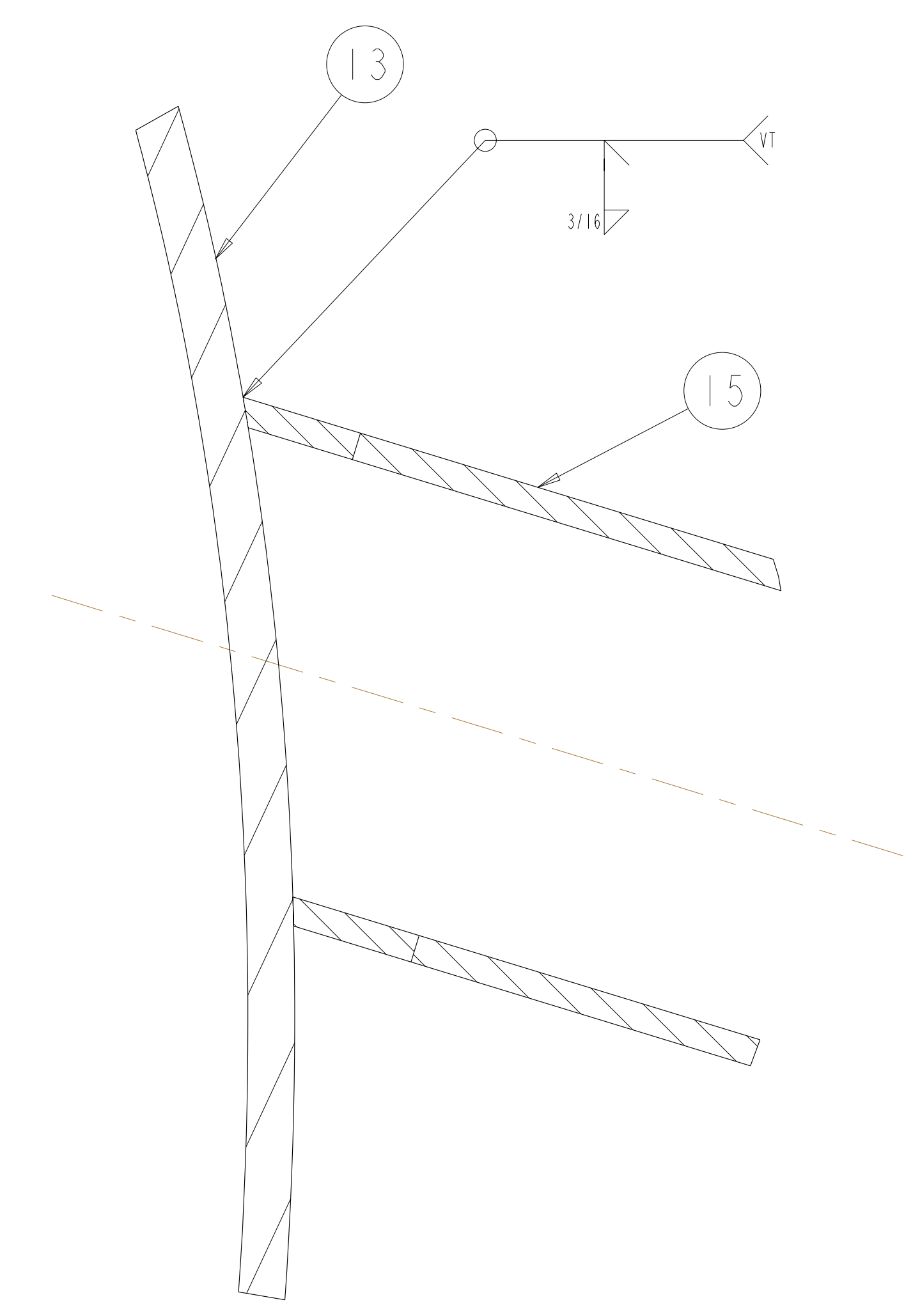

DETAIL X
SCALE 1.00

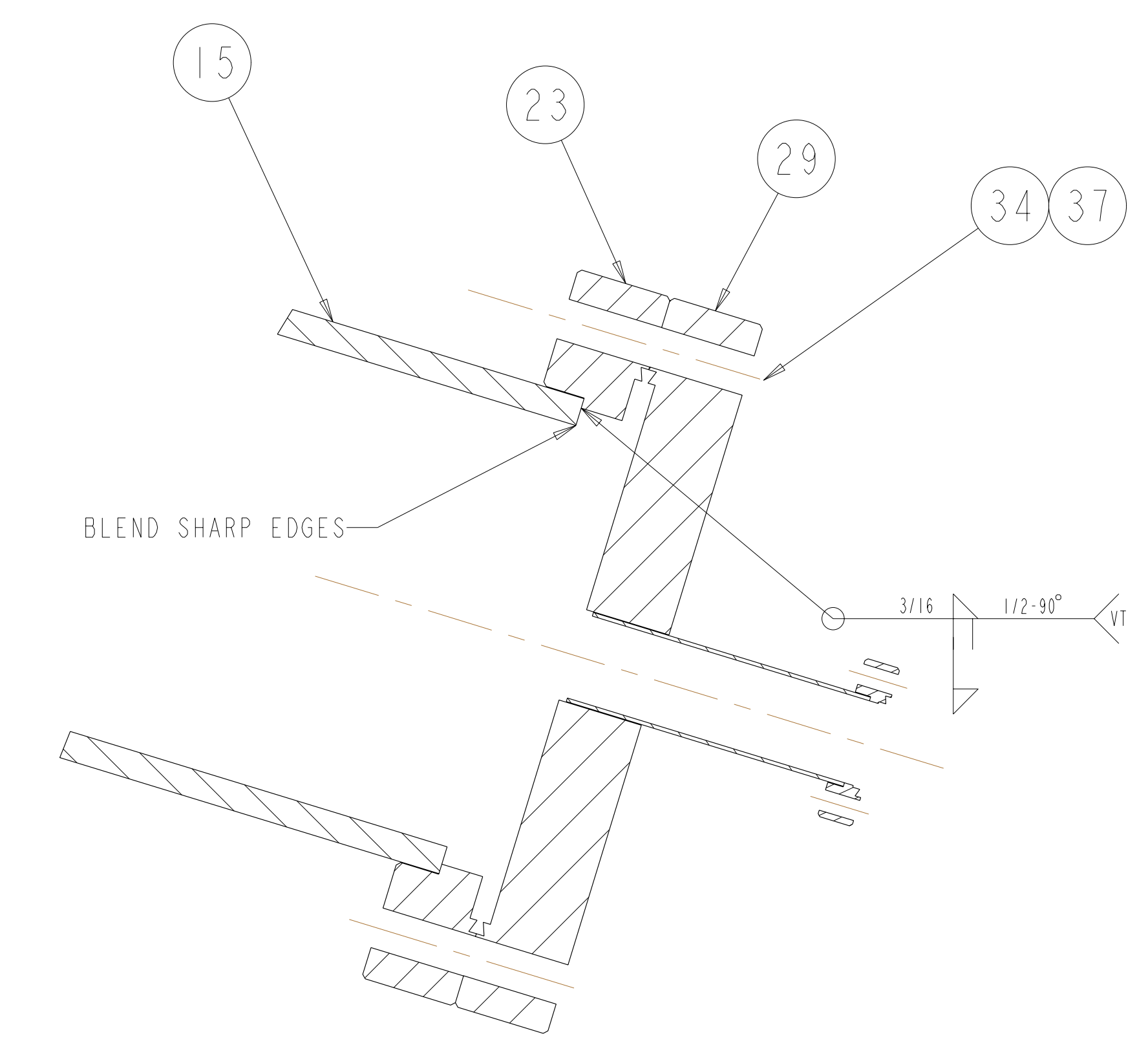

DETAIL Y
SCALE 1.00

Rev 2-e: ECN-5021 (RFD-12-017) approved alternate methods for welding the port extensions to the VVSA (See ECN-5021 for details). - Only applicable to VVSA #3 - VVSA #1 and #2 covered by NCR 19464.

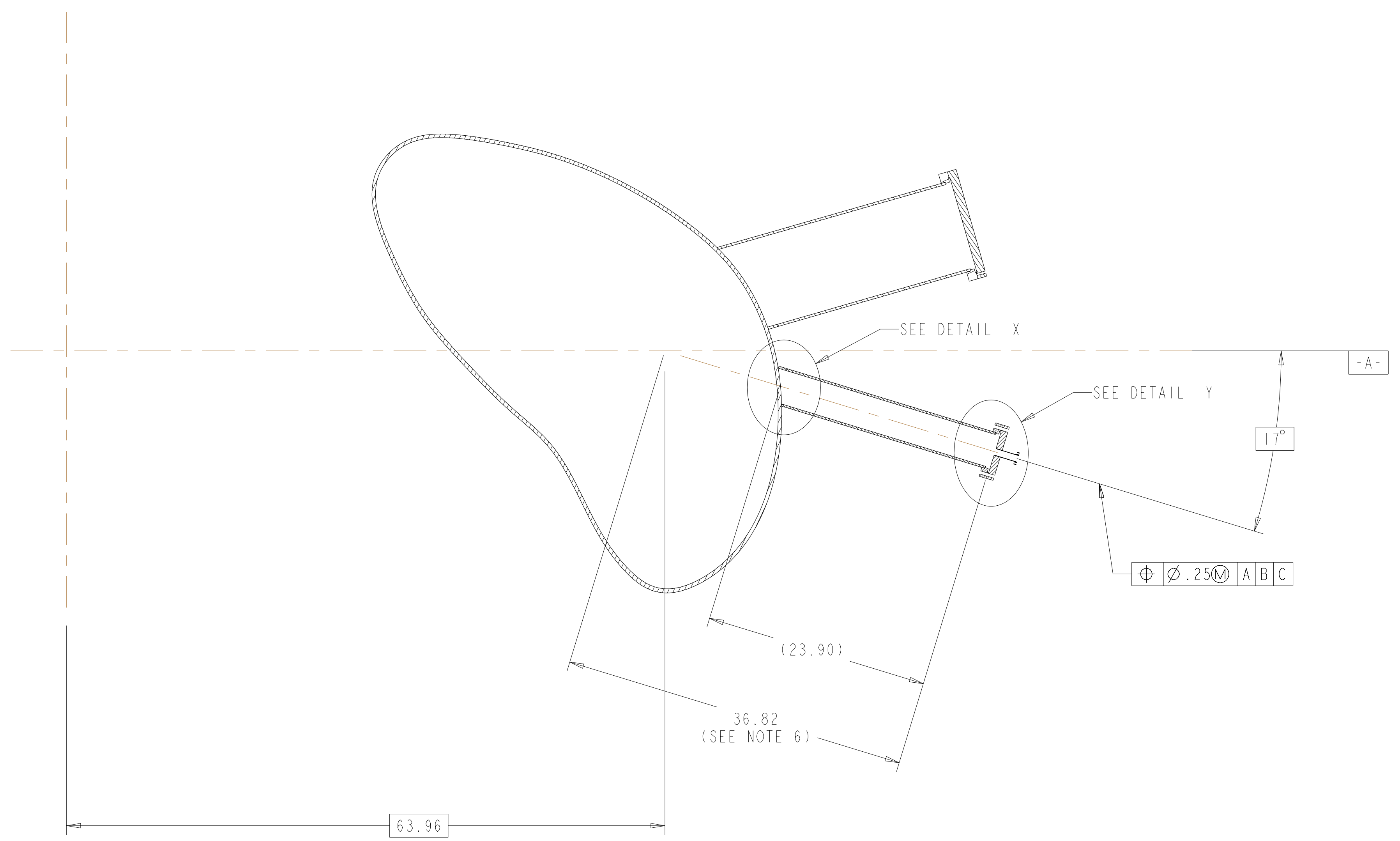

TYPICAL PORT 15A AND 15B
SECTION PORT15-PORT15

RELEASED FOR FABRICATION / INSTALLATION
 PPPL Drafting:

UT-BATTELLE		Oak Ridge National Laboratory managed for the DEPARTMENT OF ENERGY under U.S. GOVERNMENT contract DE-AC05-00OR22725 UT-BATTELLE, LLC, Oak Ridge, Tennessee	
PROJECT NAME			
NATIONAL COMPACT STELLARATOR EXPERIMENT			
VACUUM VESSEL			
PERIOD INSPECTION AND LEAK CHECK ASSEMBLY			
VERSION NO.	PLANT	BLDG	FL
5	X-10	5700	3
RELEASE LEVEL	SHT OF	TYPE	CLASS
Fabrication	14	A	U
SEI20-004			REV
			2

H
G
F
E
D
C
B
A

FOR PARTS LIST AND NOTES SEE SHEET 1

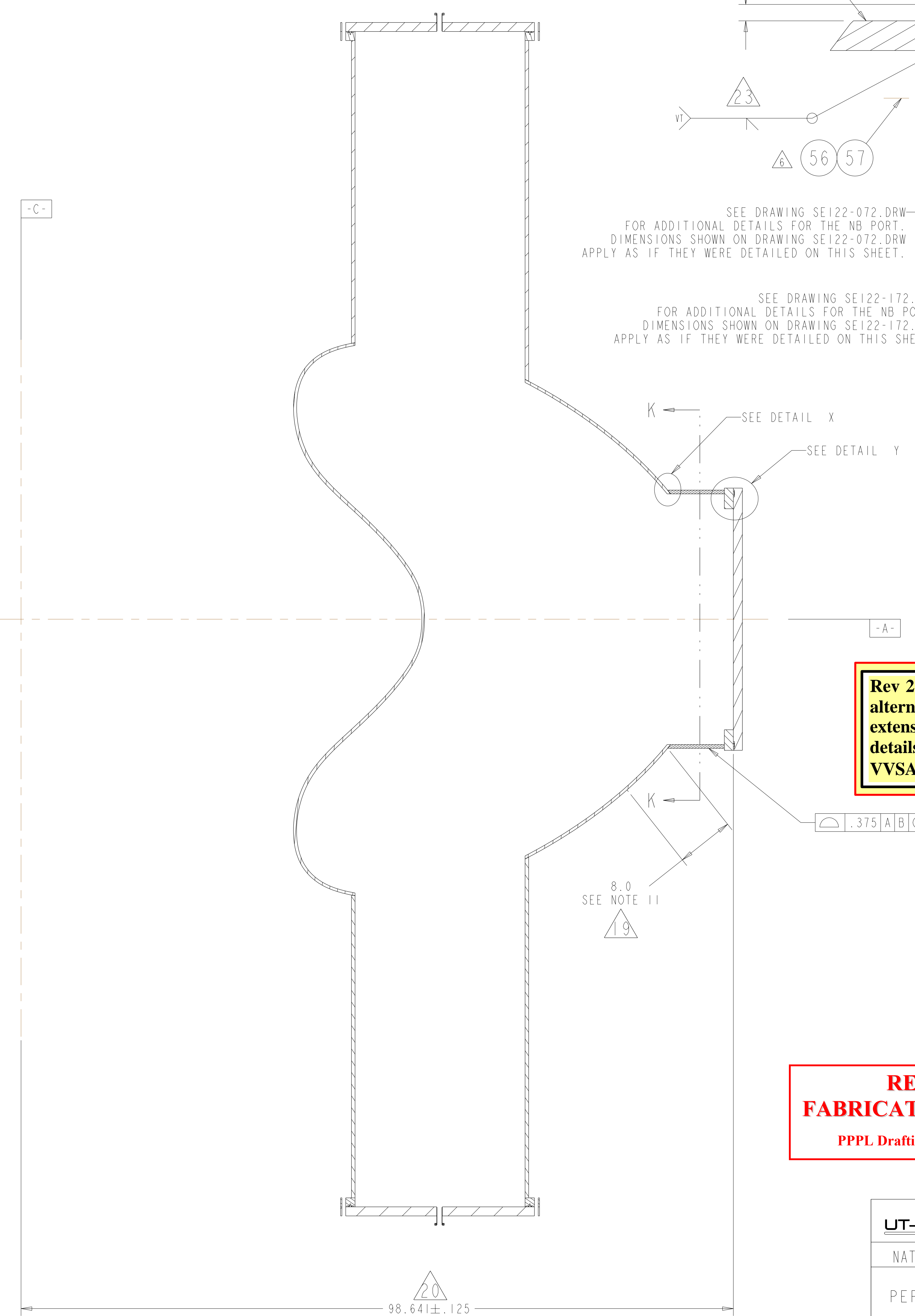
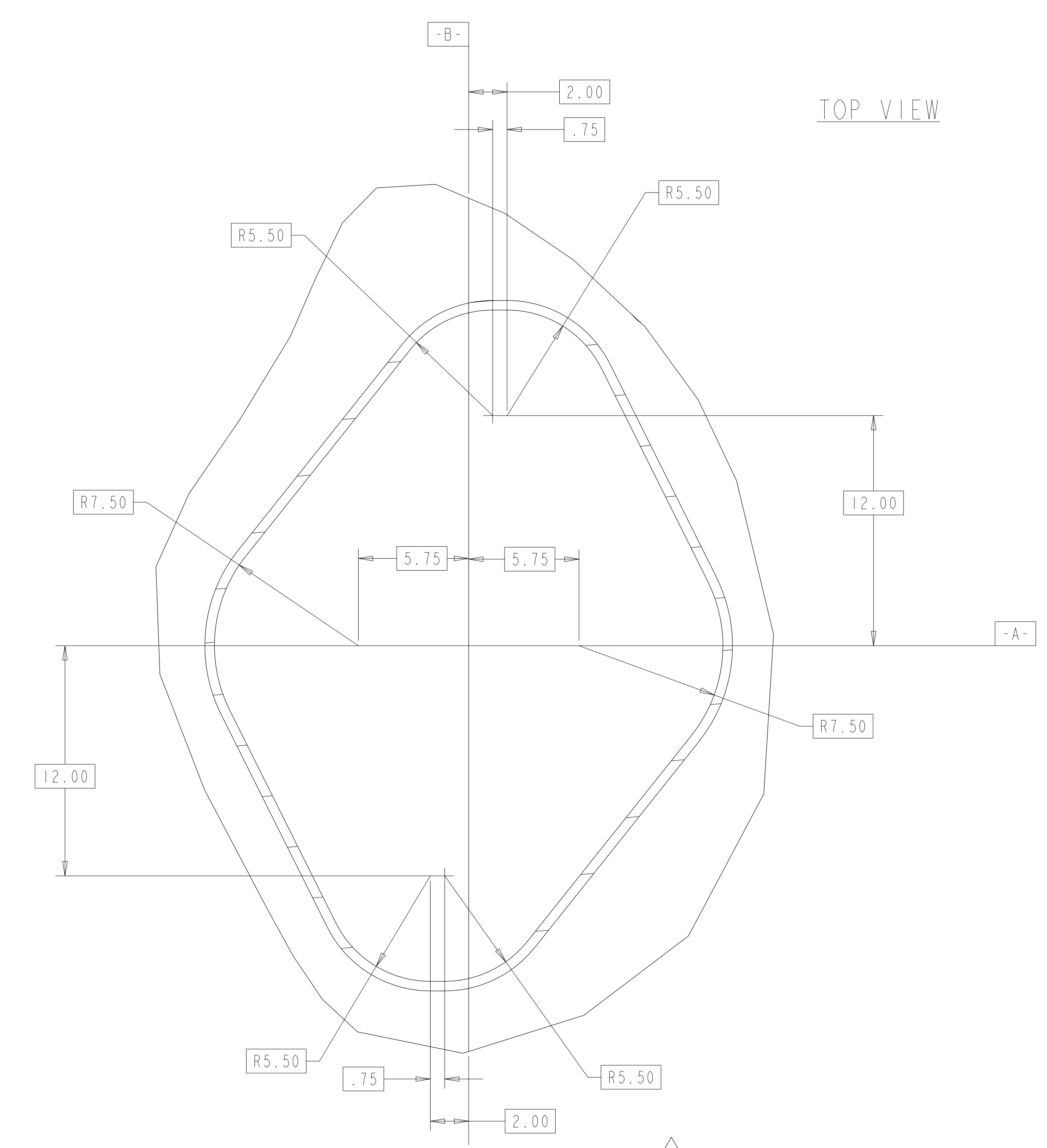
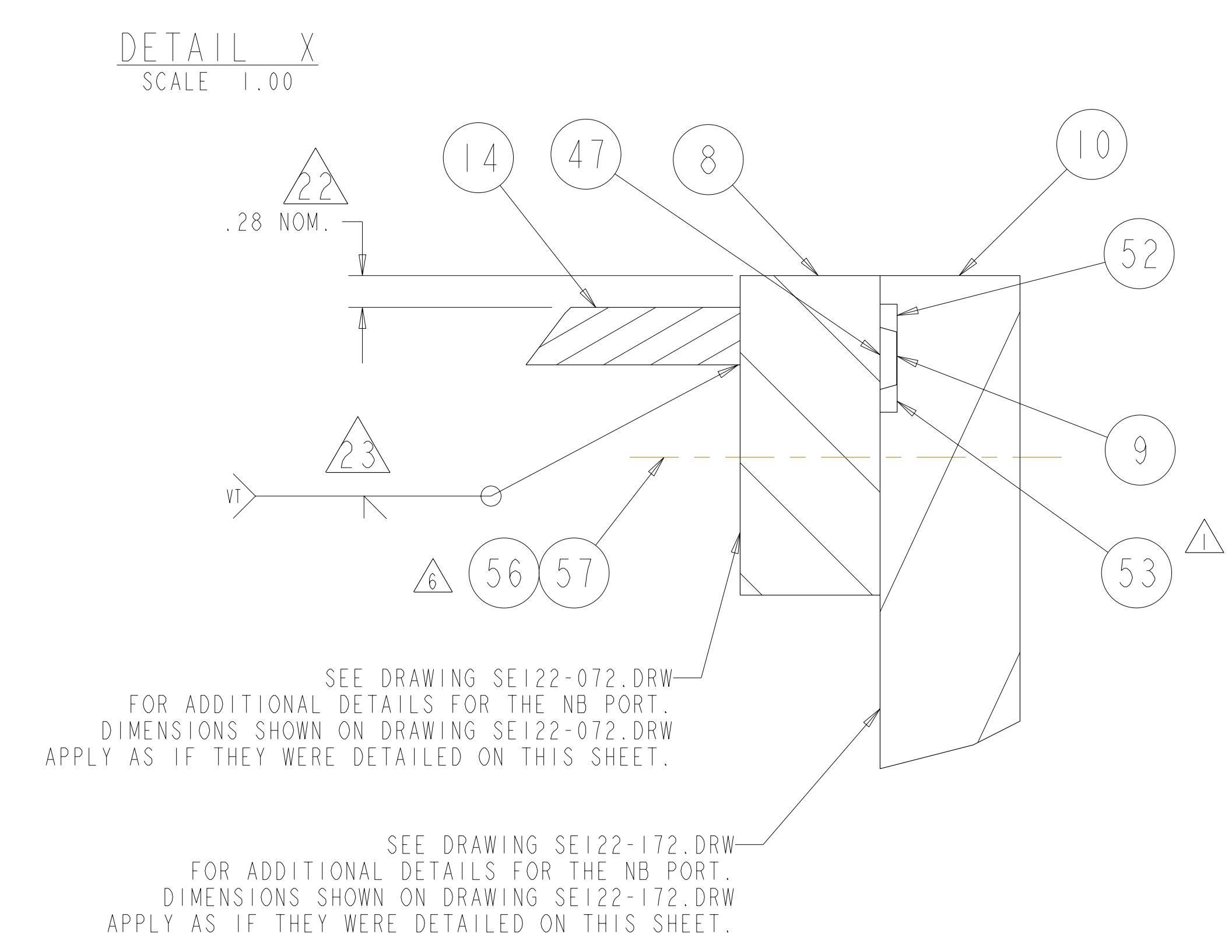
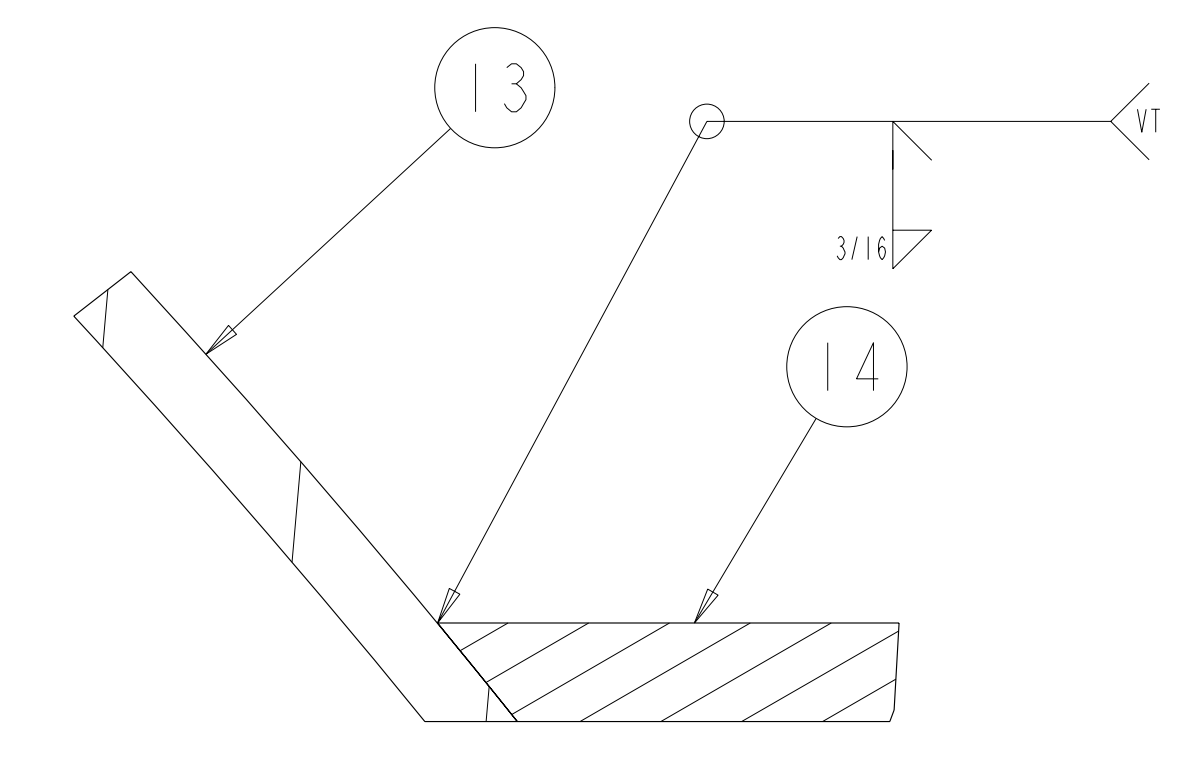
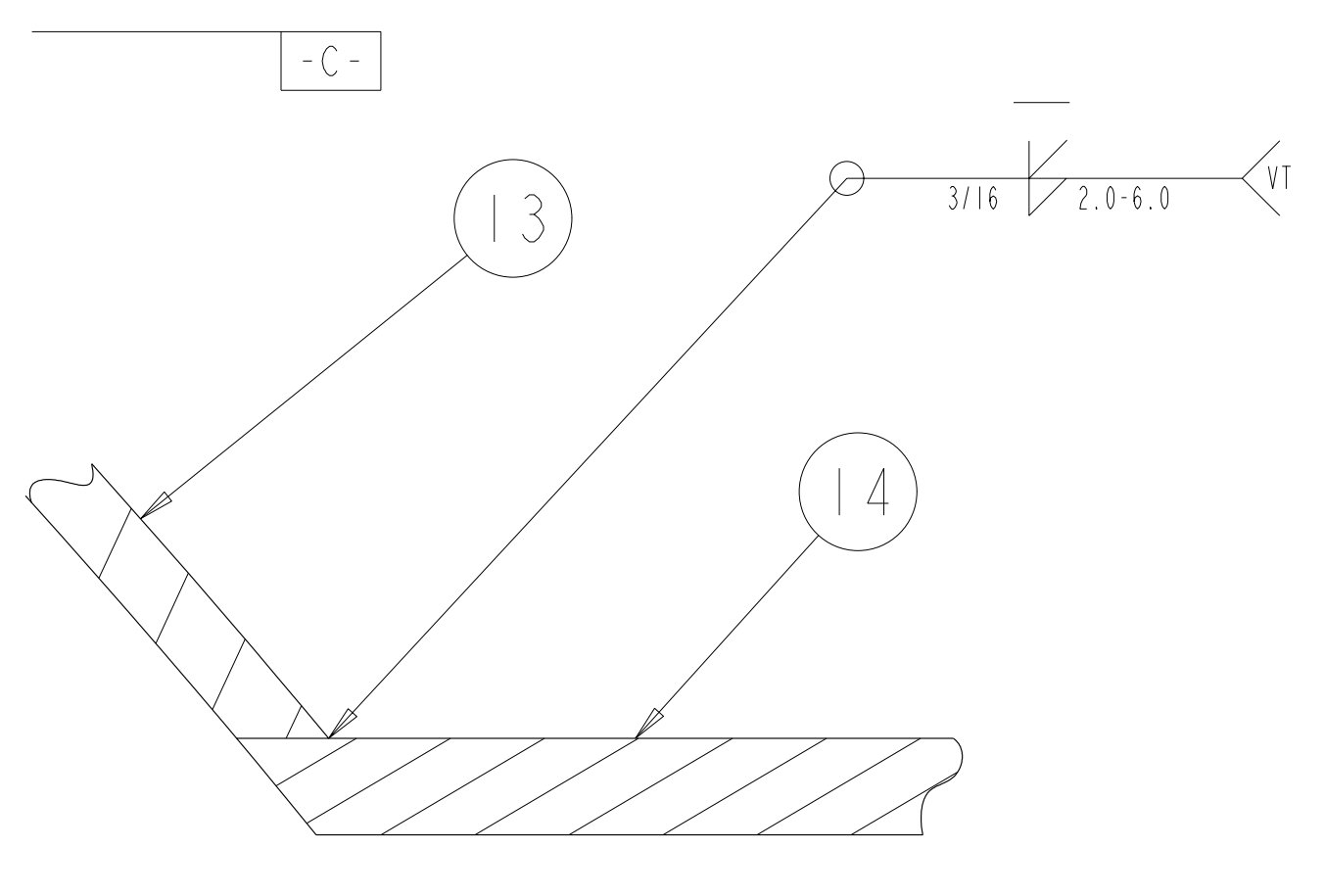
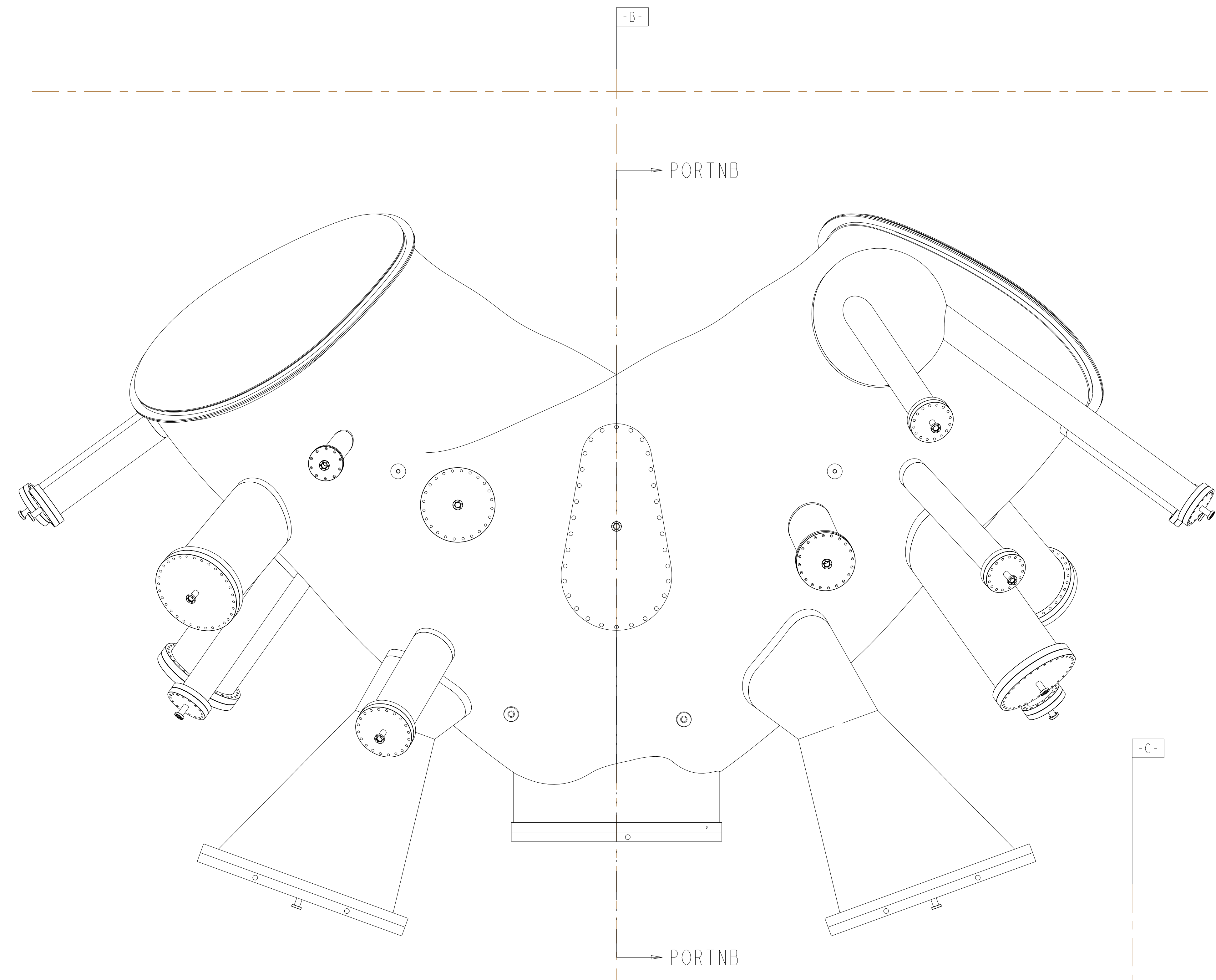

Rev 2-e: ECN-5021 (RFD-12-017) approved alternate methods for welding the port extensions to the VVSA (See ECN-5021 for details). - Only applicable to VVSA #3 - VVSA #1 and #2 covered by NCR 19464.

RELEASED FOR FABRICATION / INSTALLATION
 PPPL Drafting:

UT-BATTELLE						Oak Ridge National Laboratory managed for the DEPARTMENT OF ENERGY under U.S. GOVERNMENT contract DE-AC05-00OR22725 UT-BATTELLE, LLC, Oak Ridge, Tennessee					
NATIONAL COMPACT STELLARATOR EXPERIMENT											
VACUUM VESSEL PERIOD INSPECTION AND LEAK CHECK ASSEMBLY											
VERSION NO.	PLANT	BLDG	FL	SHT OF	TYPE	CLASS					
5	X-10	5700	3	15	A	U					
RELEASE LEVEL	SE120-004										
Fabrication											

FOR PARTS LIST AND NOTES SEE SHEET 1.

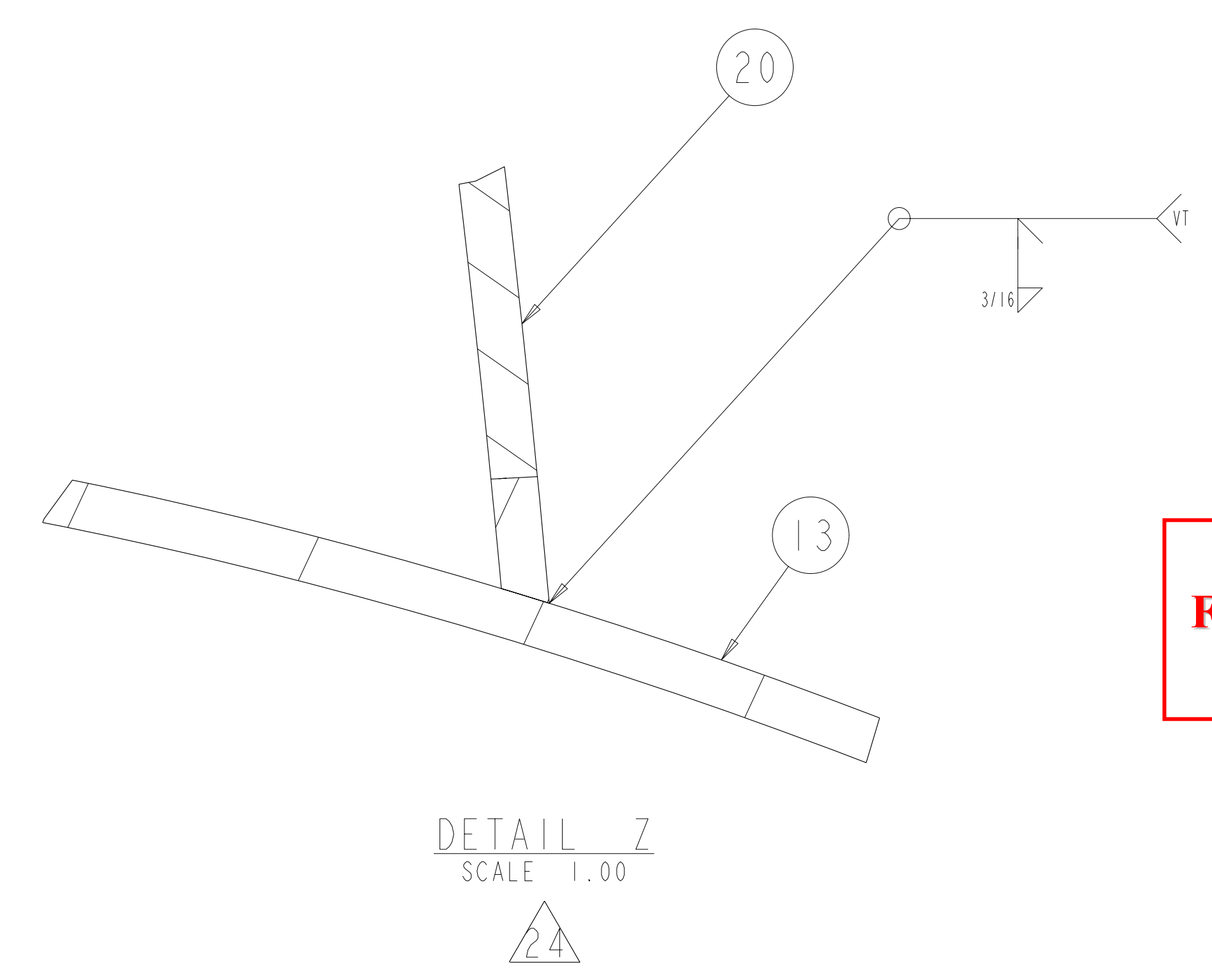
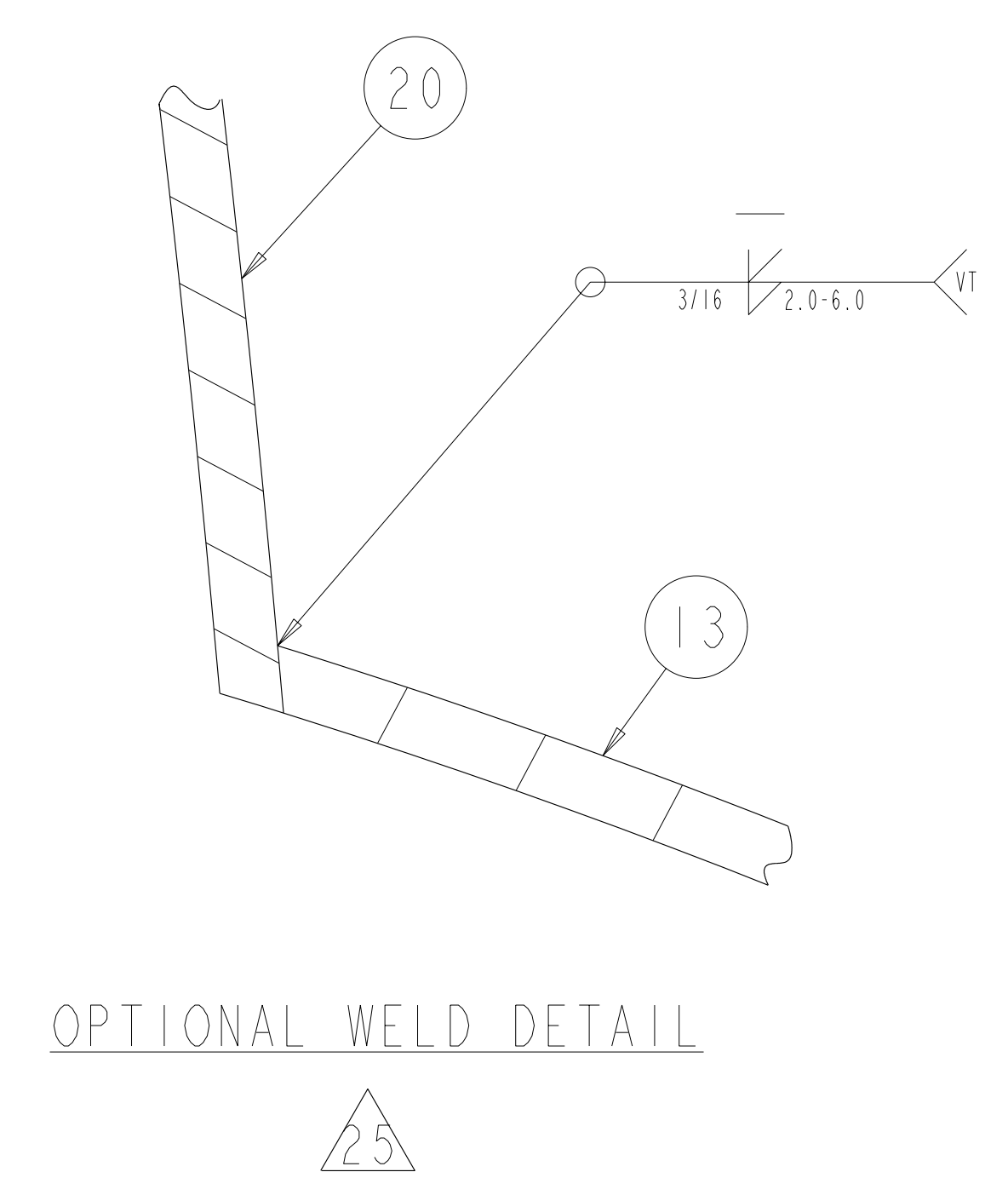
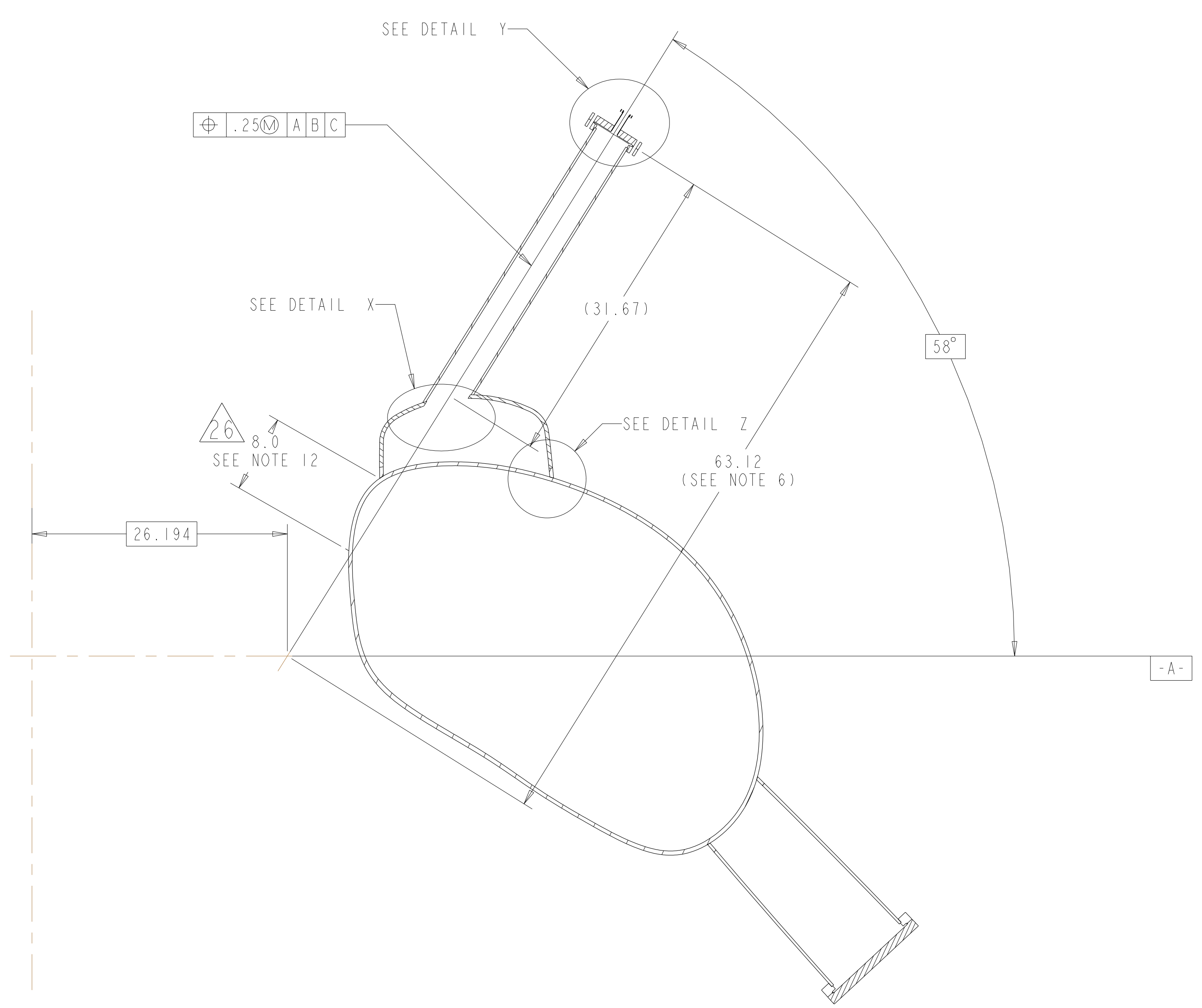
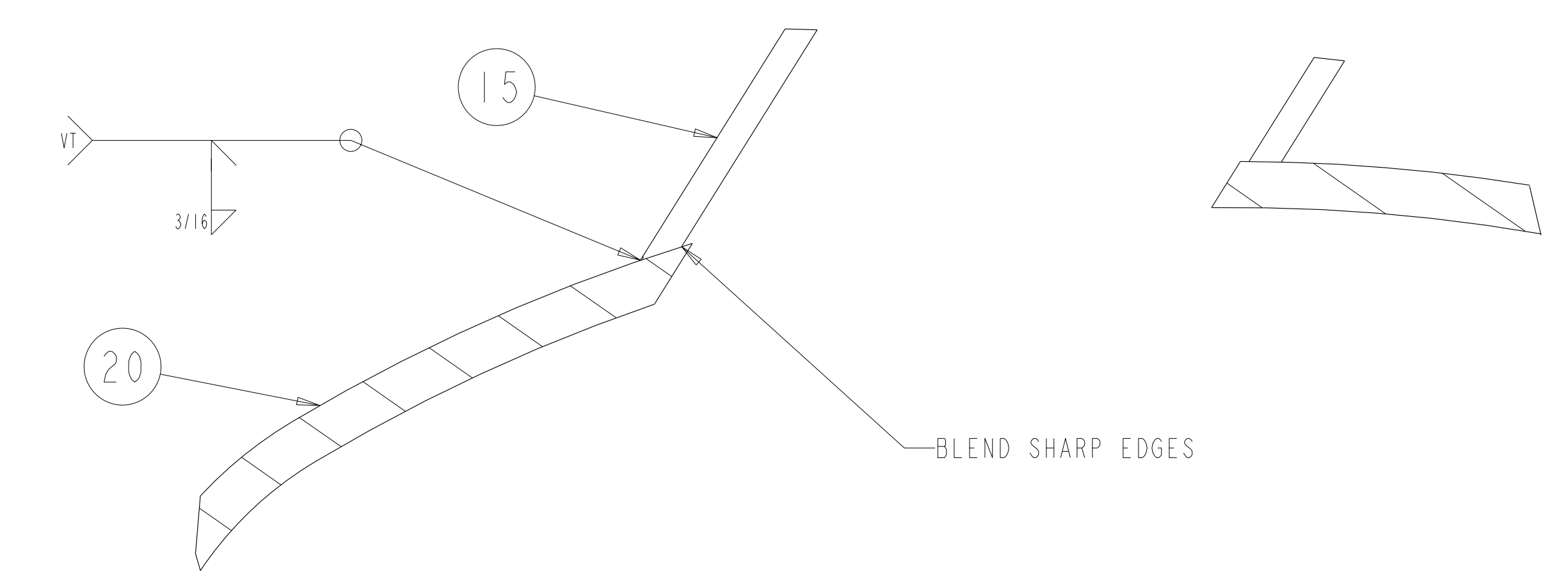
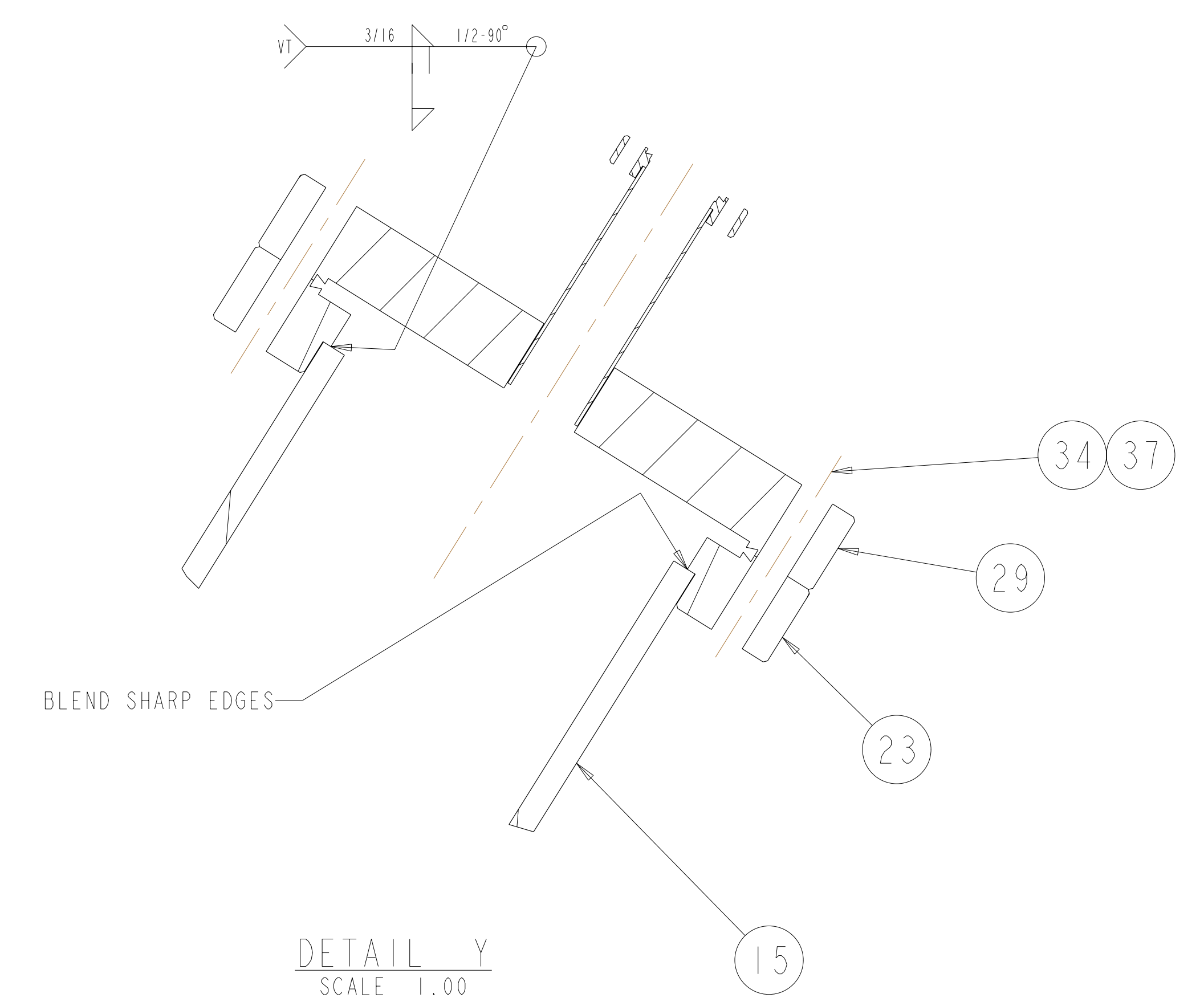
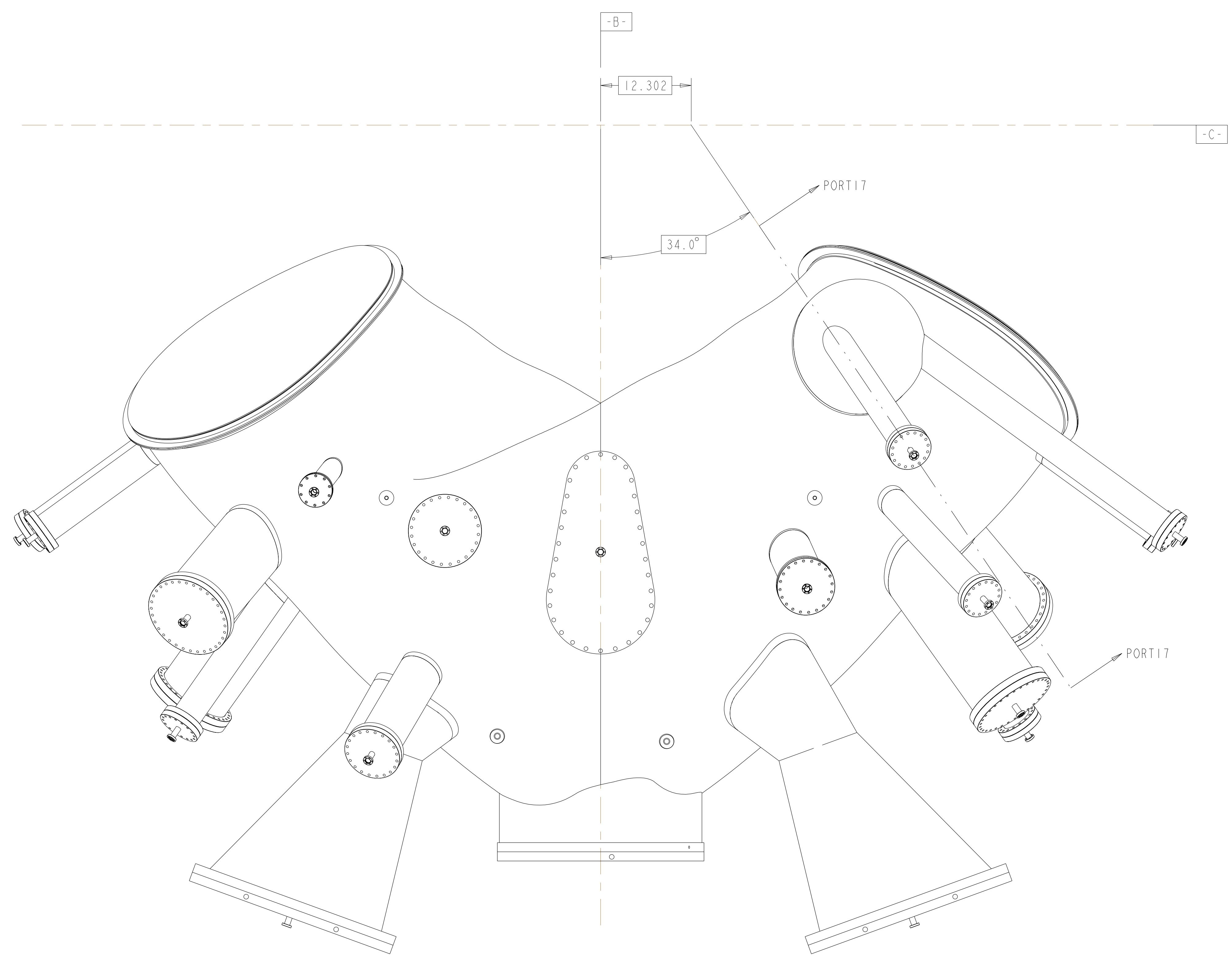

Rev 2-e: ECN-5021 (RFD-12-017) approved alternate methods for welding the port extensions to the VVSA (See ECN-5021 for details). - Only applicable to VVSA #3 - VVSA #1 and #2 covered by NCR 19464.

RELEASED FOR FABRICATION / INSTALLATION
 PPPL Drafting:

UT-BATTELLE		Oak Ridge National Laboratory managed for the DEPARTMENT OF ENERGY under U.S. GOVERNMENT contract DE-AC05-00OR22725 UT-BATTELLE, LLC, Oak Ridge, Tennessee					
PROJECT NAME							
NATIONAL COMPACT STELLARATOR EXPERIMENT							
VACUUM VESSEL							
PERIOD INSPECTION AND LEAK CHECK							
ASSEMBLY							
VERSION NO.	PLANT	BLDG	FL	SHT OF	TYPE	CLASS	
5	X-10	5700	3	16	19	A	U
RELEASE LEVEL		SEI20-004					REV
Fabrication							2

H
G
F
E
D
C
B
A

FOR PARTS LIST AND NOTES SEE SHEET 1.

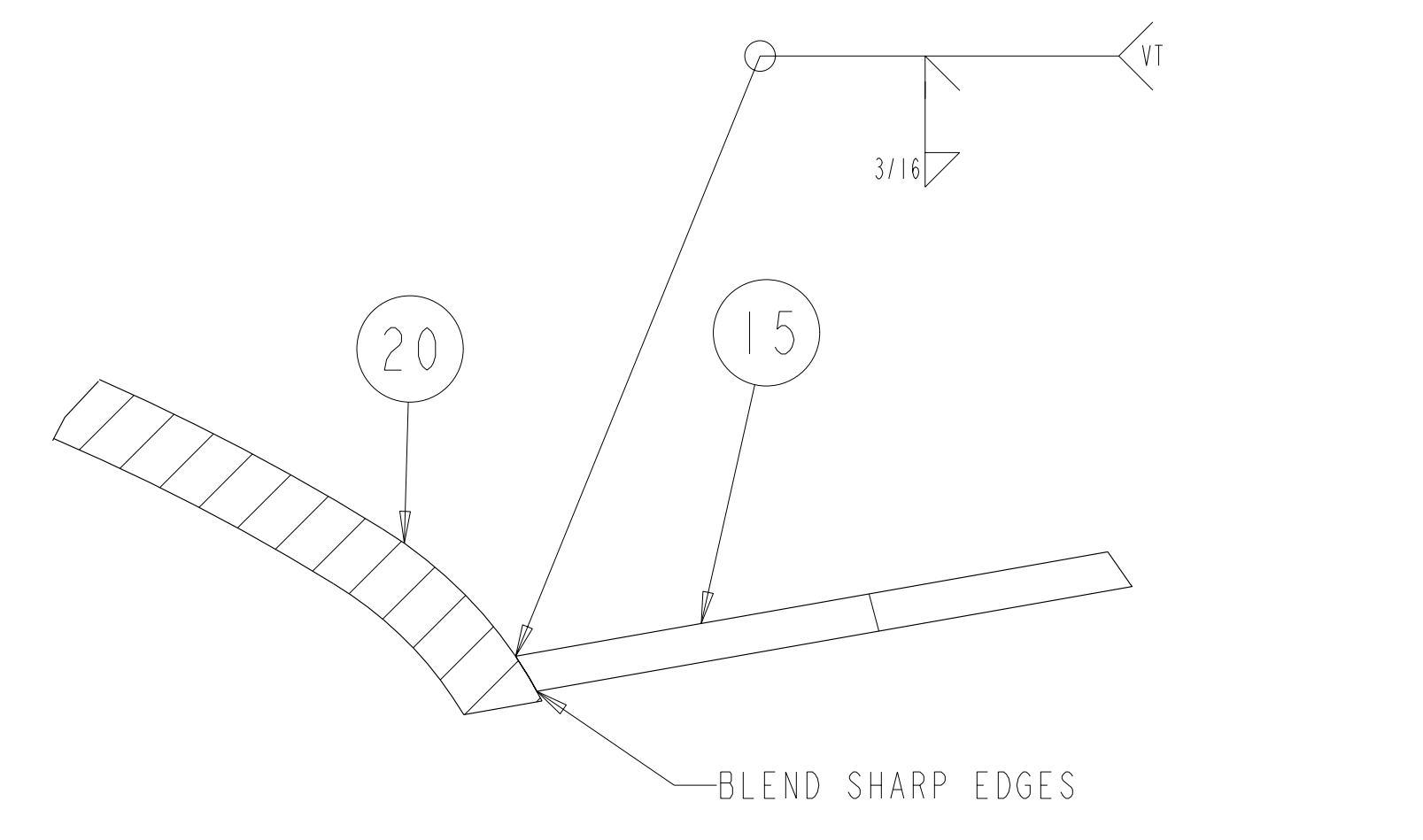
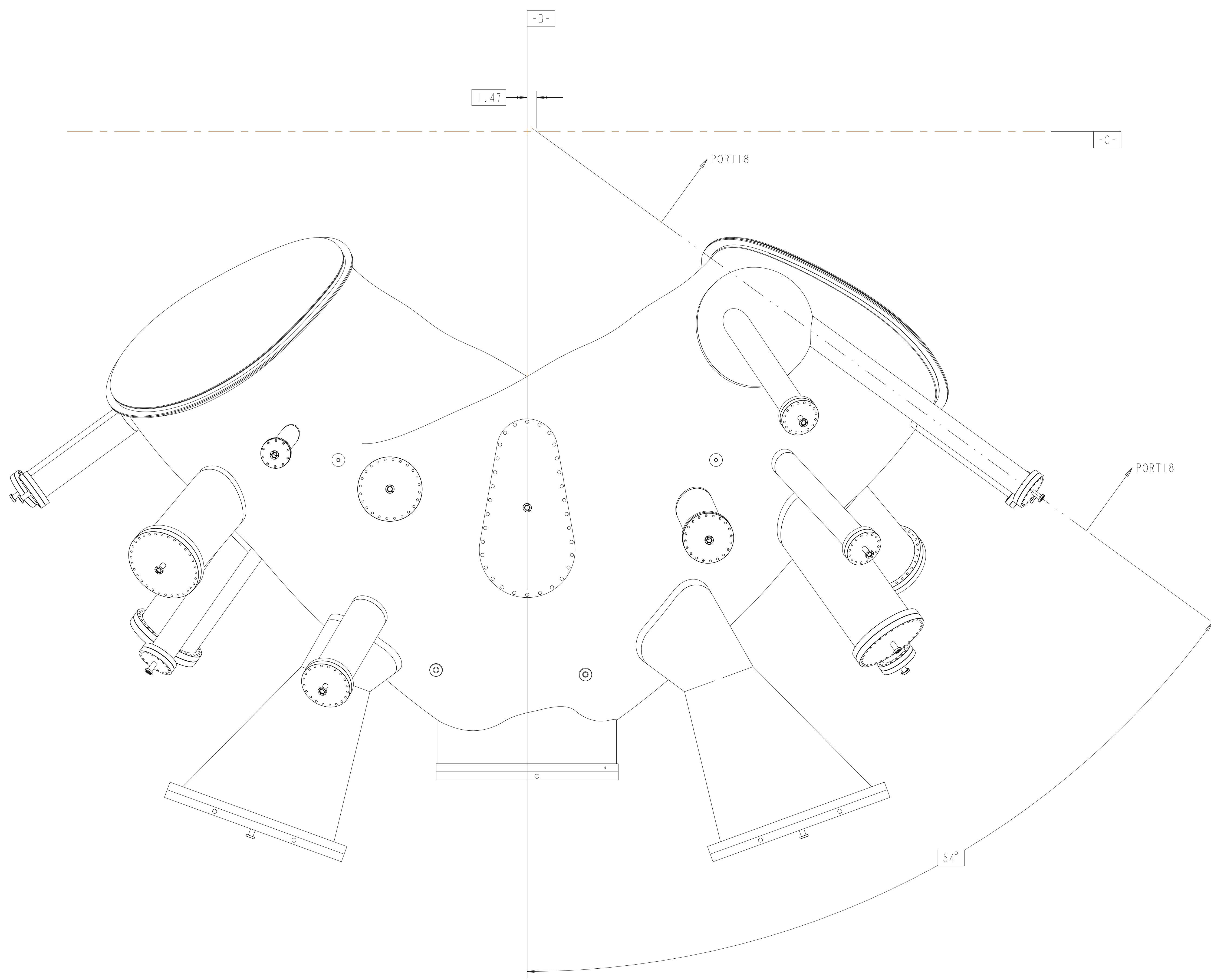

DETAIL X
SCALE 1.00

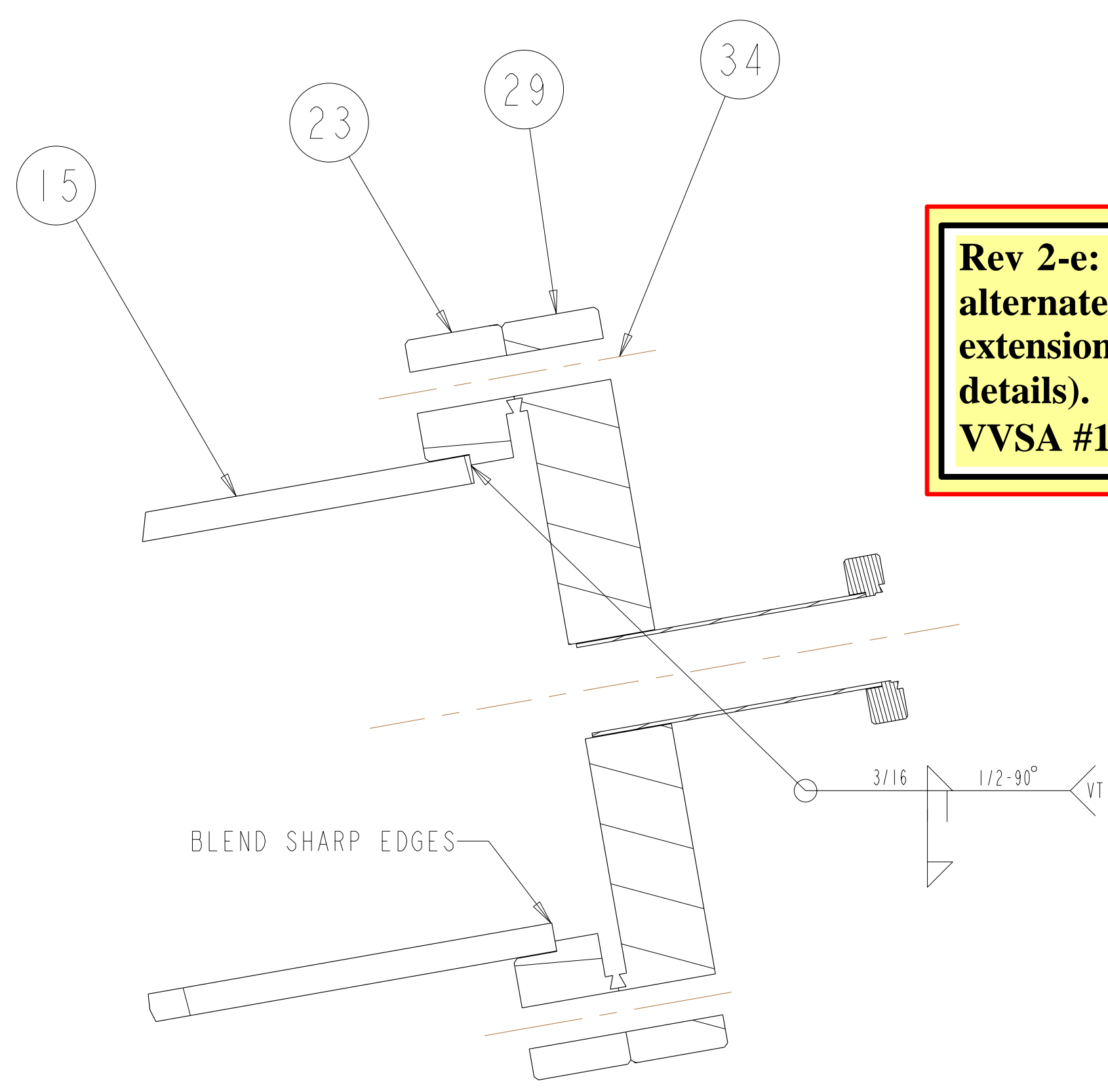

DETAIL Y
SCALE 1.000

Rev 2-e: ECN-5021 (RFD-12-017) approved alternate methods for welding the port extensions to the VVSA (See ECN-5021 for details). - Only applicable to VVSA #3 - VVSA #1 and #2 covered by NCR 19464.

RELEASED FOR FABRICATION / INSTALLATION
PPPL Drafting:

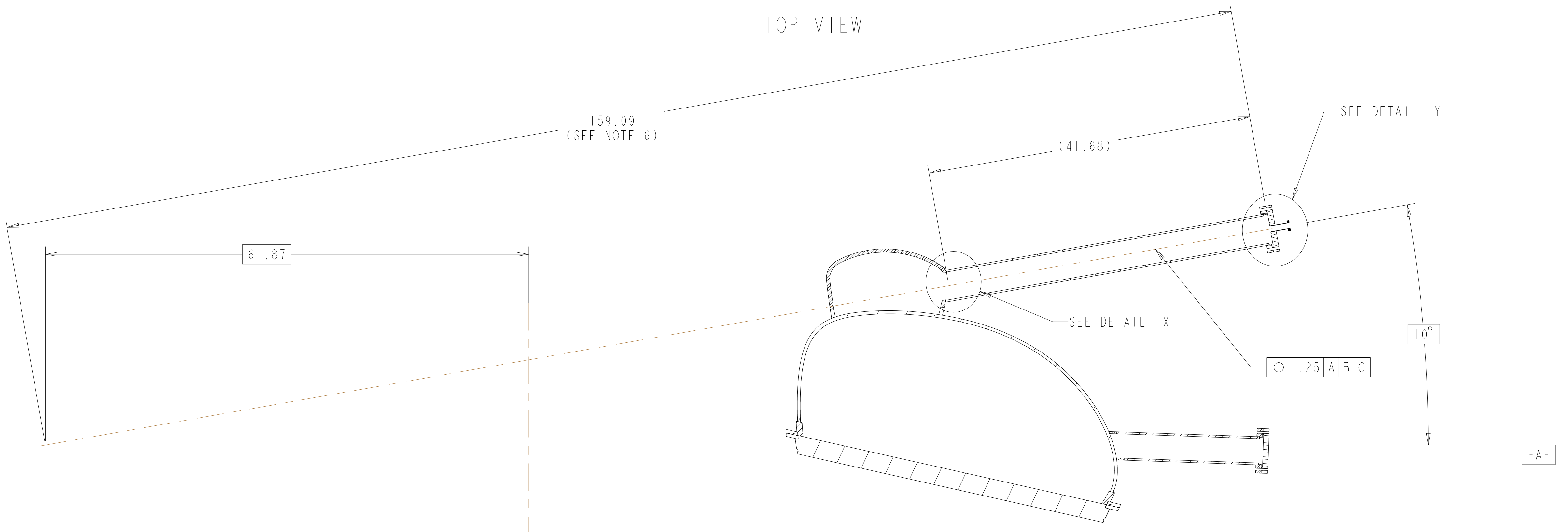

TYPICAL PORT 18A AND 18B
SECTION PORT18-PORT18

UT-BATTELLE		Oak Ridge National Laboratory managed for the DEPARTMENT OF ENERGY under U.S. GOVERNMENT contract DE-AC05-00OR22725 UT-BATTELLE, LLC., Oak Ridge, Tennessee						
PROJECT NAME								
NATIONAL COMPACT STELLARATOR EXPERIMENT								
VACUUM VESSEL								
PERIOD INSPECTION AND LEAK CHECK								
ASSEMBLY								
VERSION NO.	PLANT	BLDG	FL	SHT OF	TYPE	CLASS		
5	X-10	5700	3	17 19	A	U		
RELEASE LEVEL		SE120-004					REV	
Fabrication							2	

FOR PARTS LIST AND NOTES SEE SHEET 1.

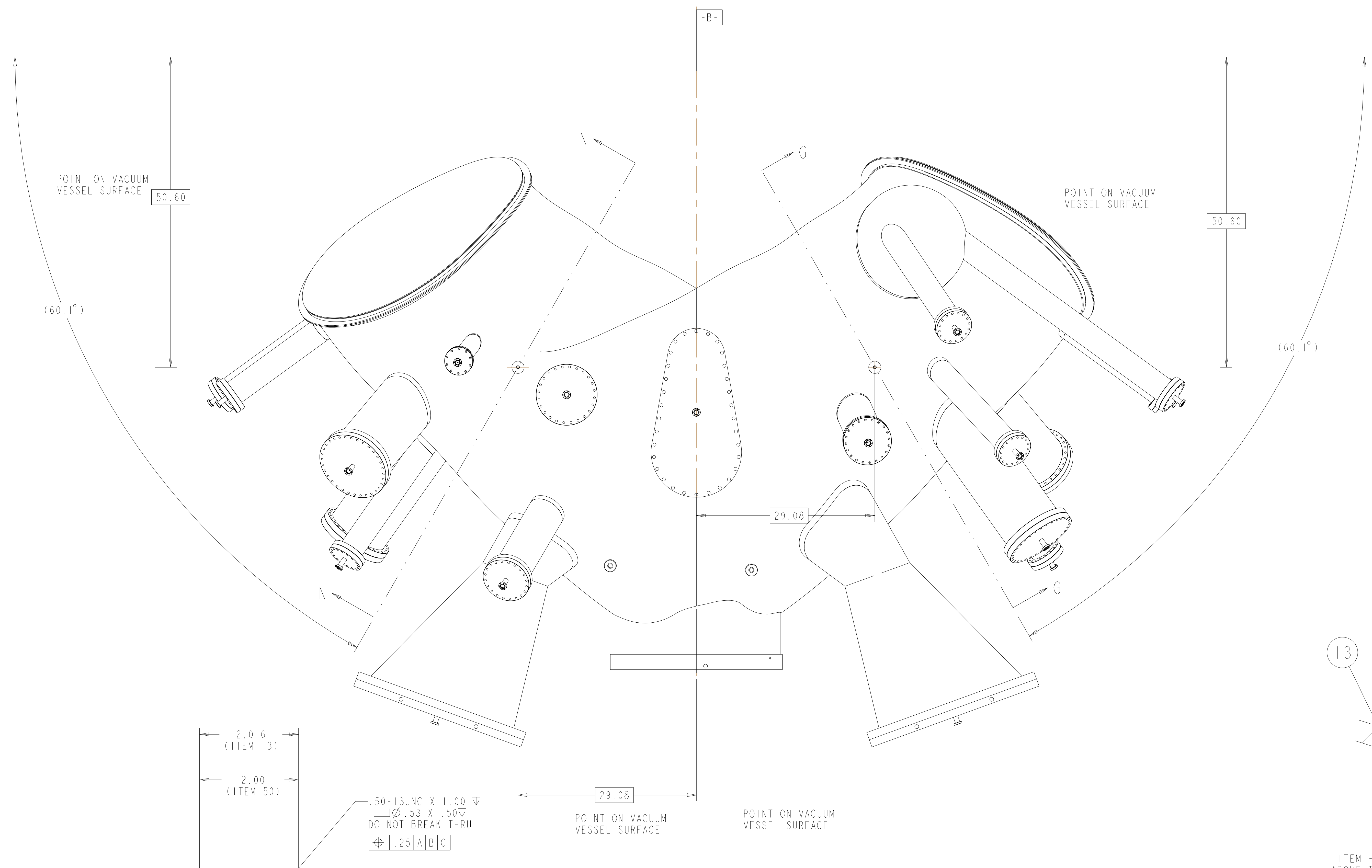

TOP VIEW

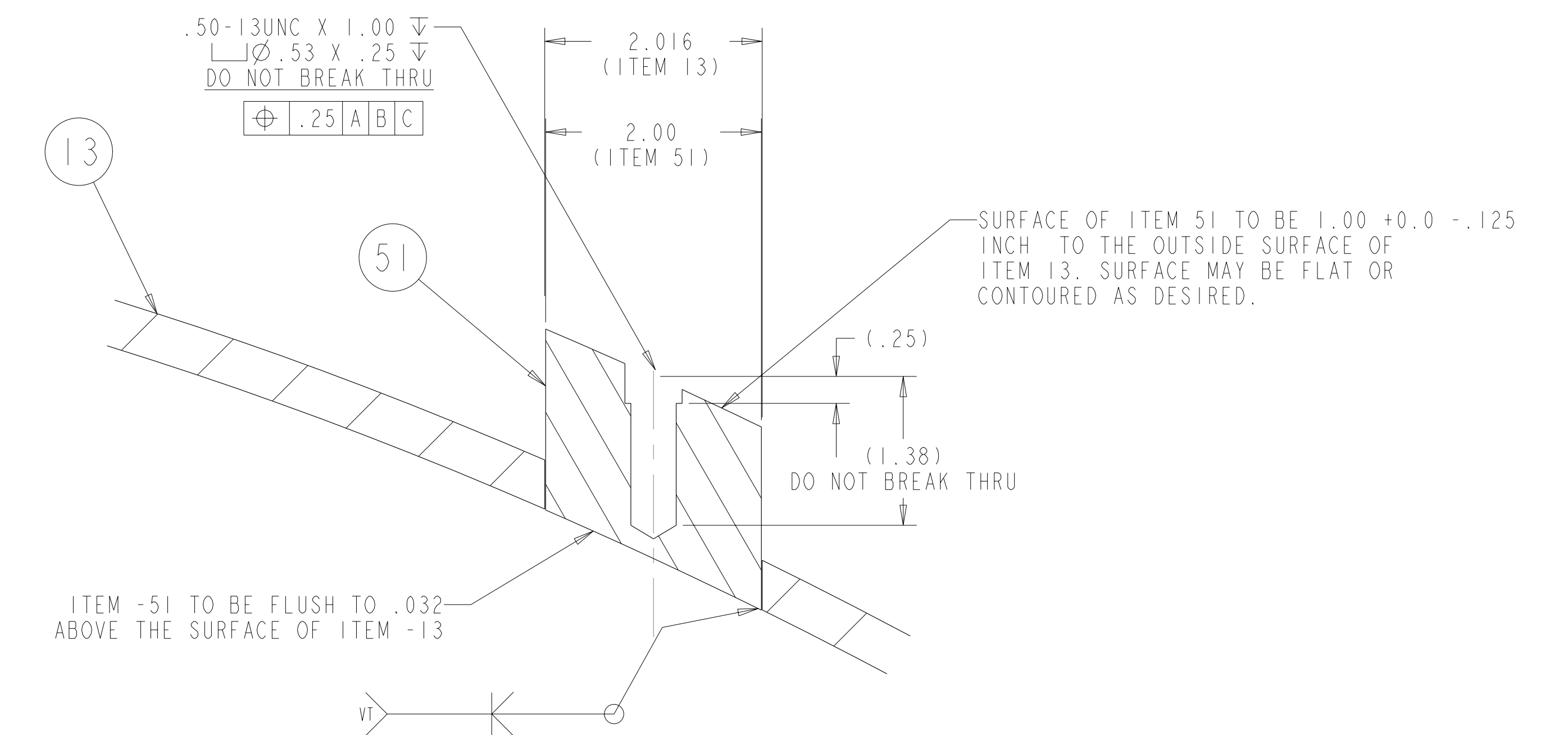

DETAIL X
TYPICAL 2 PLACES
SCALE 1.00

Rev 2-e: ECN-5021 (RFD-12-017) approved alternate methods for welding the port extensions to the VVSA (See ECN-5021 for details). - Only applicable to VVSA #3 - VVSA #1 and #2 covered by NCR 19464.

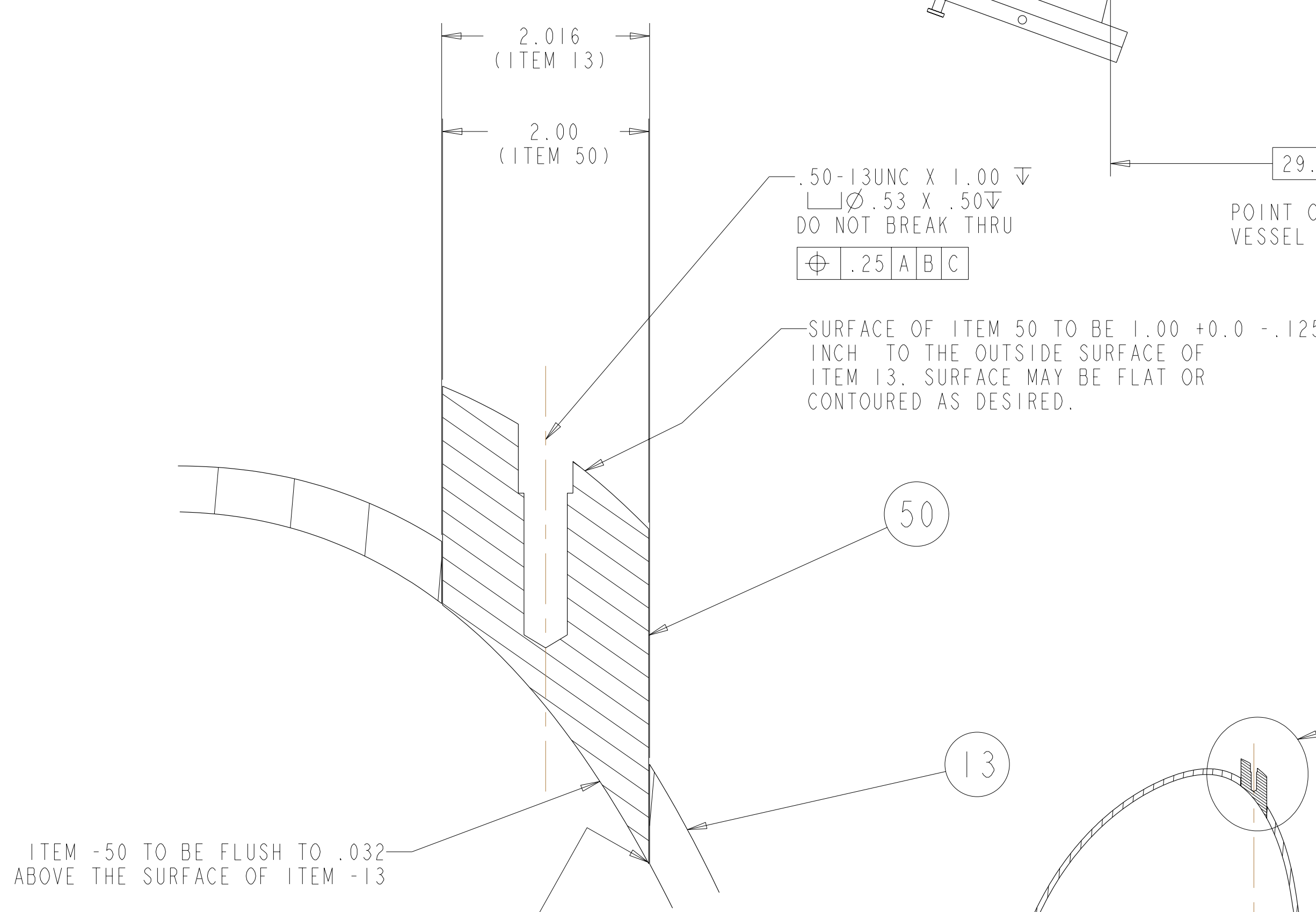

DETAIL Z
SCALE 1.00

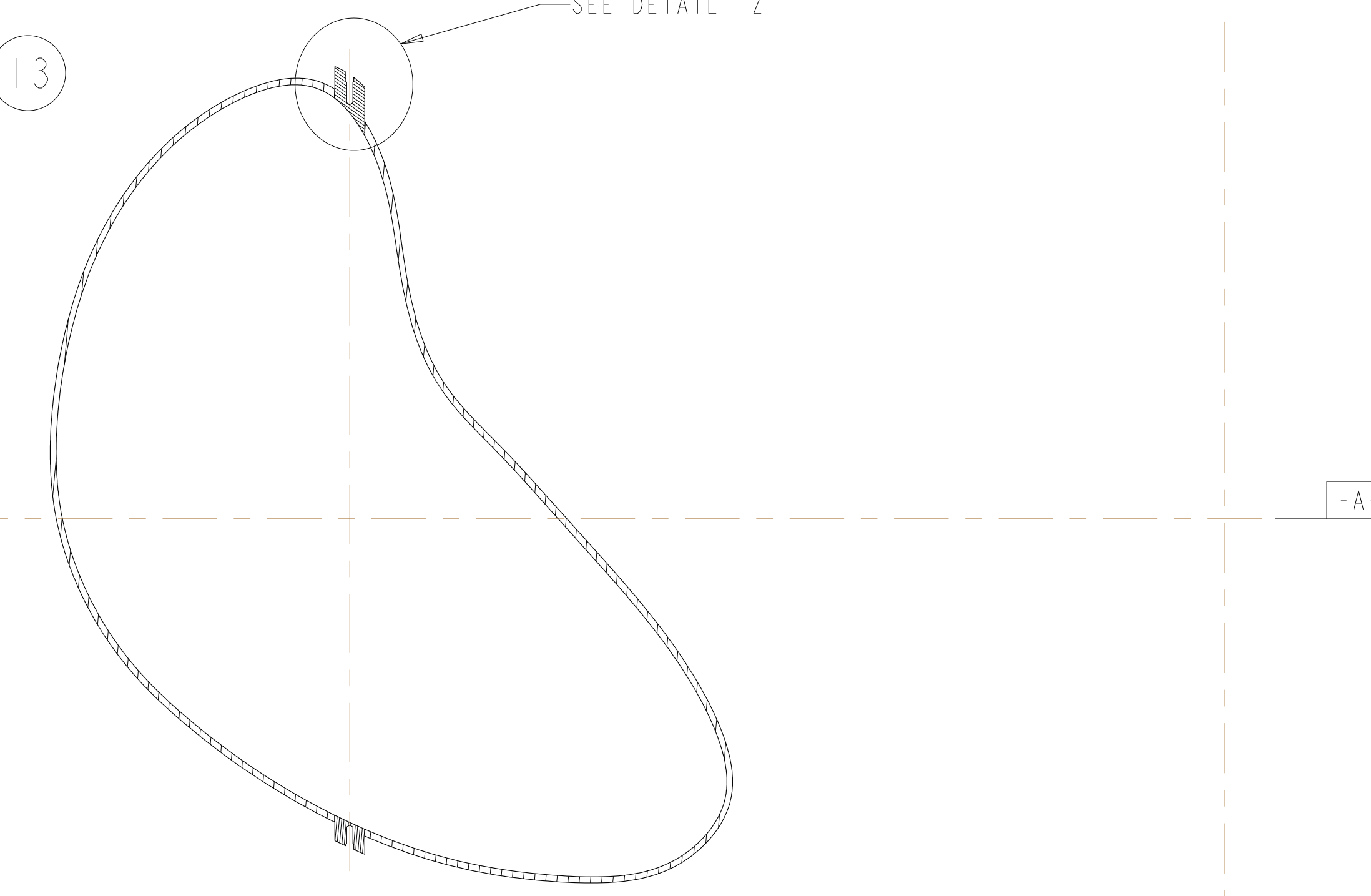

SECTION N-N

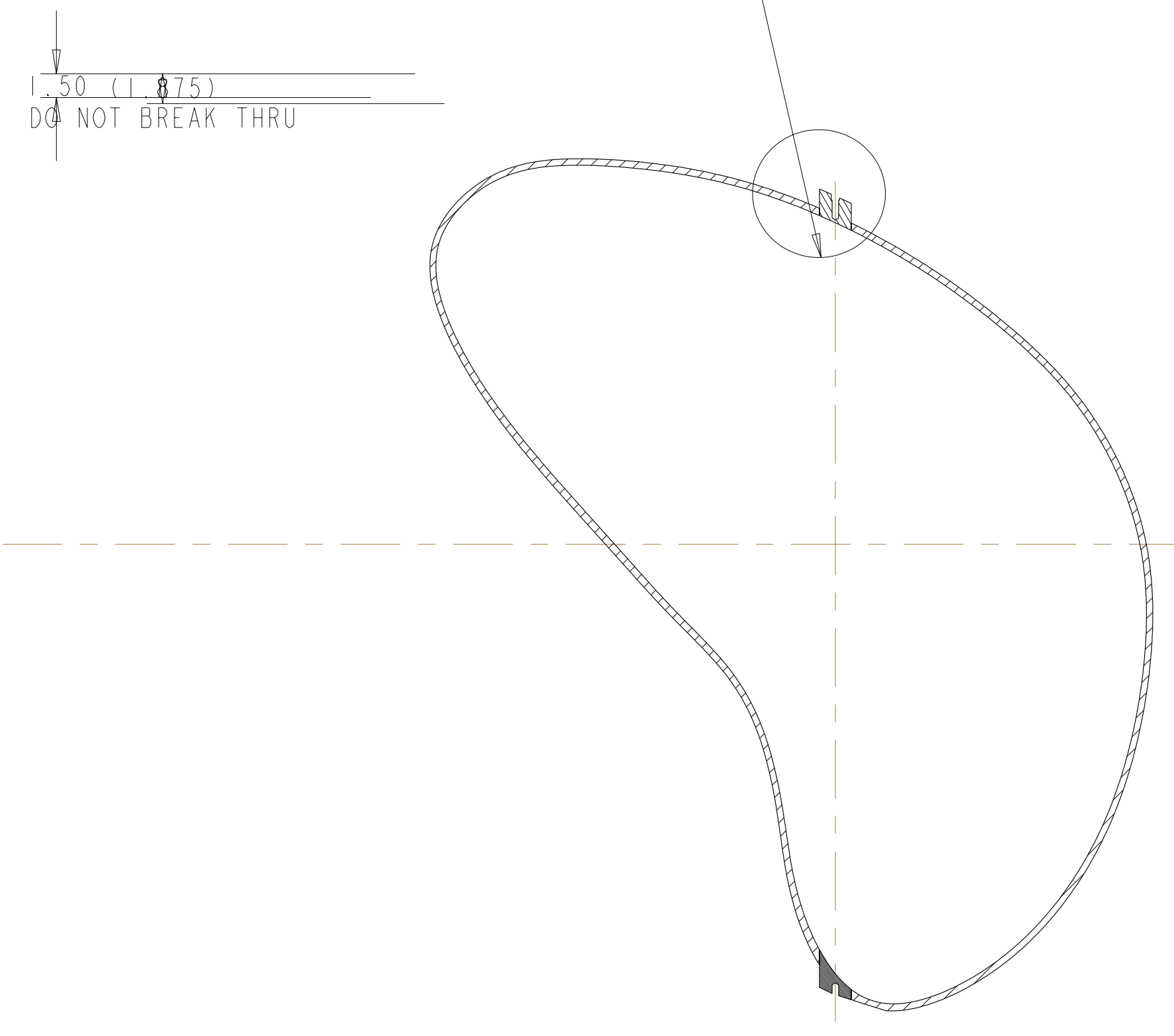

SECTION G-G

RELEASED FOR FABRICATION / INSTALLATION
PPPL Drafting:

UT-BATTELLE		Oak Ridge National Laboratory managed for the DEPARTMENT OF ENERGY under U.S. GOVERNMENT contract DE-AC05-00OR22725 UT-BATTELLE, LLC, Oak Ridge, Tennessee	
PROJECT NAME			
NATIONAL COMPACT STELLARATOR EXPERIMENT			
VACUUM VESSEL PERIOD INSPECTION AND LEAK CHECK ASSEMBLY			
VERSION NO.	PLANT	BLDG	FL SHT OF TYPE CLASS
3+	X-10	5700	3 8 19 A U
RELEASE LEVEL		REV	
Fabrication		2	
SEI20-004			

H
G
F
E
D
C
B
A

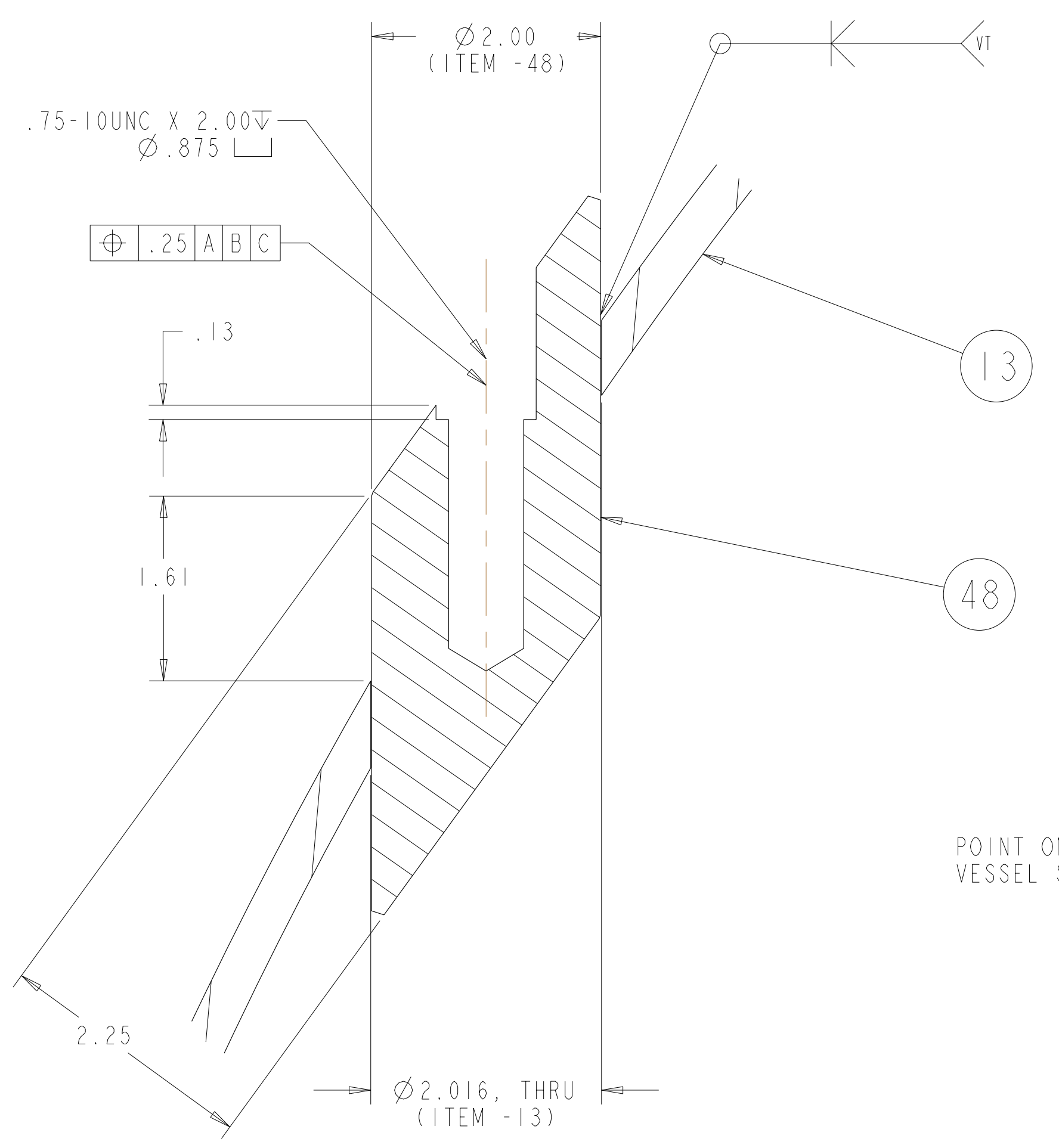

DETAIL W
 SCALE 1.00

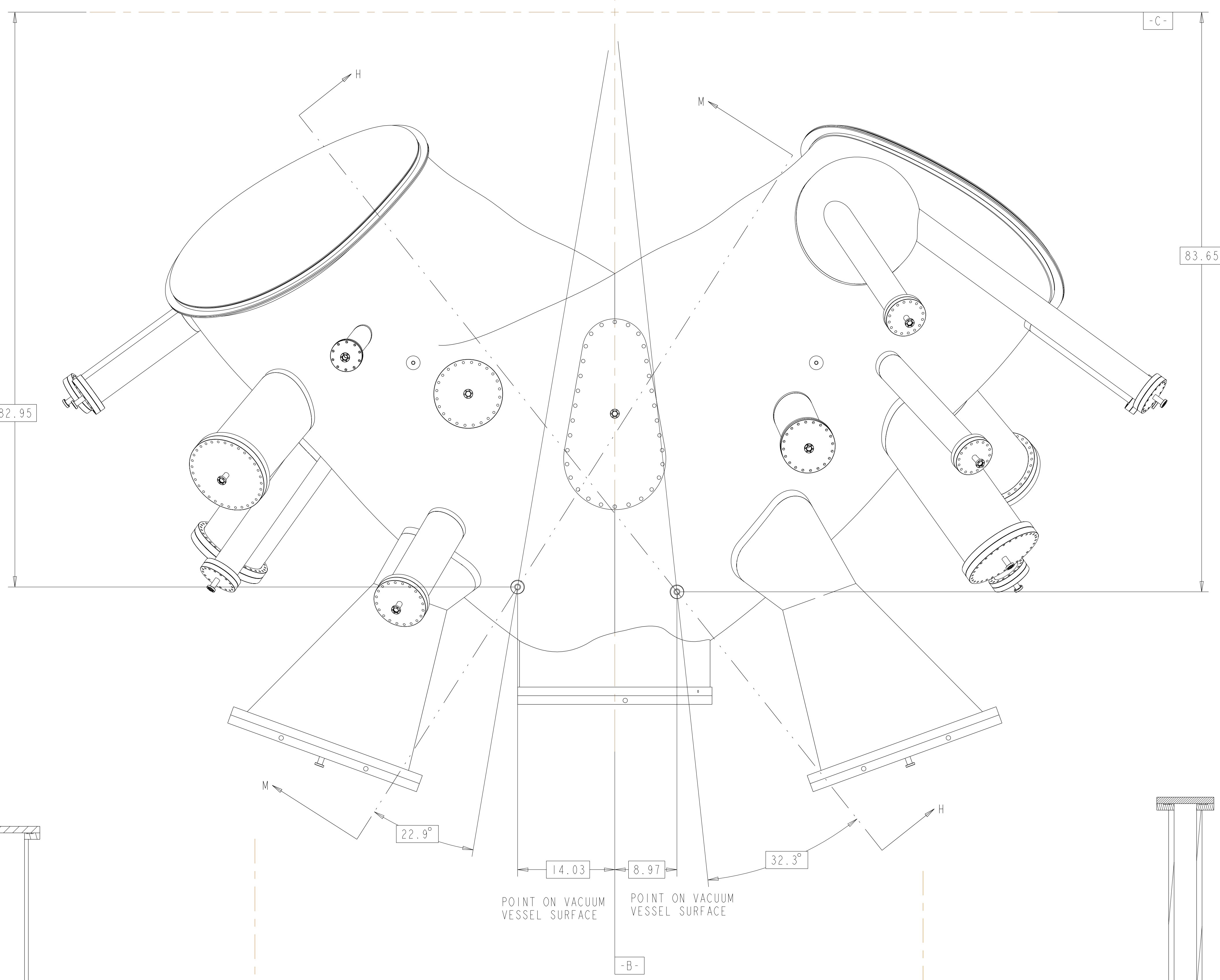

TOP VIEW

FOR PARTS LIST AND NOTES SEE SHEET 1.

POINT ON VACUUM VESSEL SURFACE

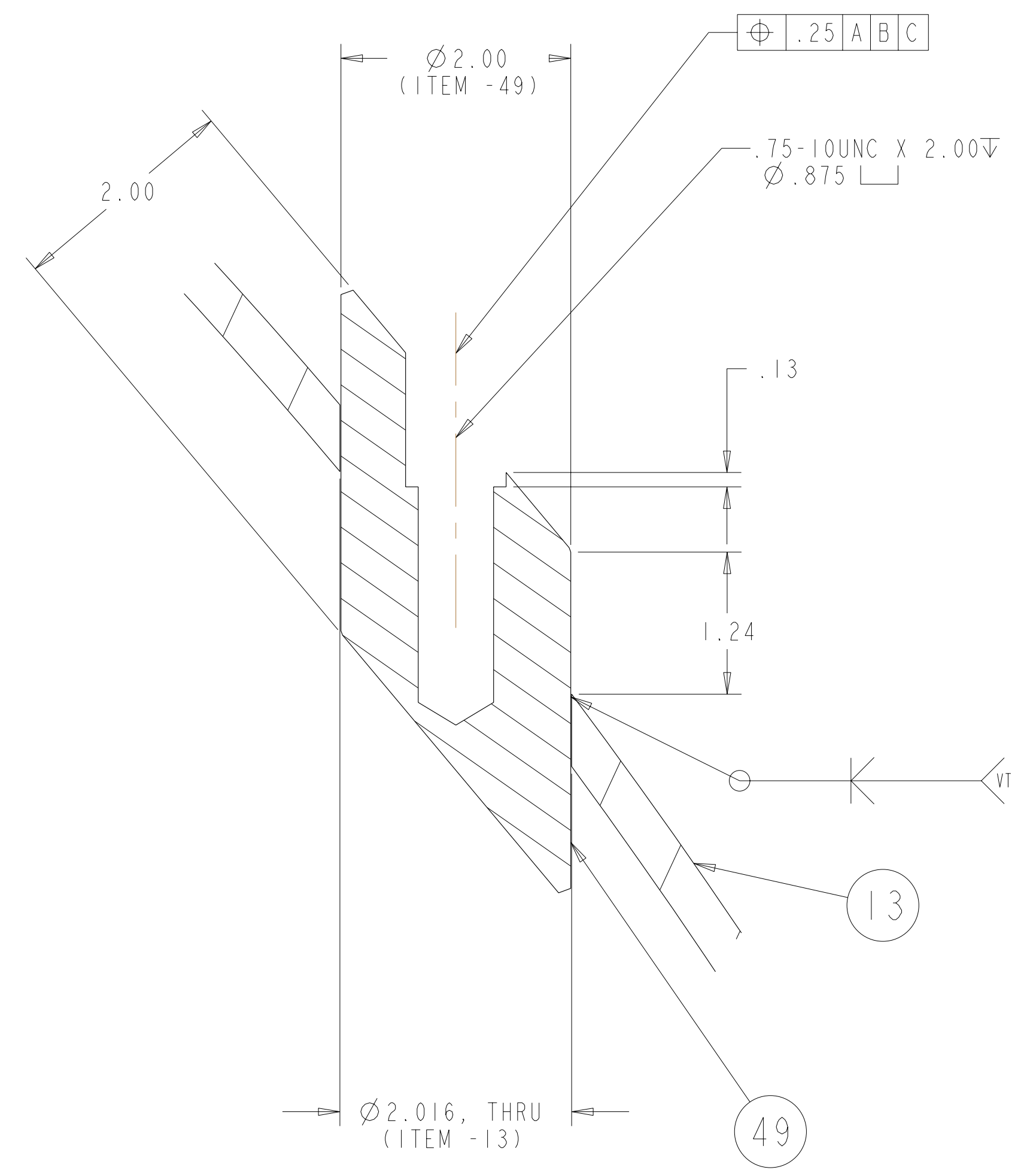

DETAIL Y
 SCALE 1.00

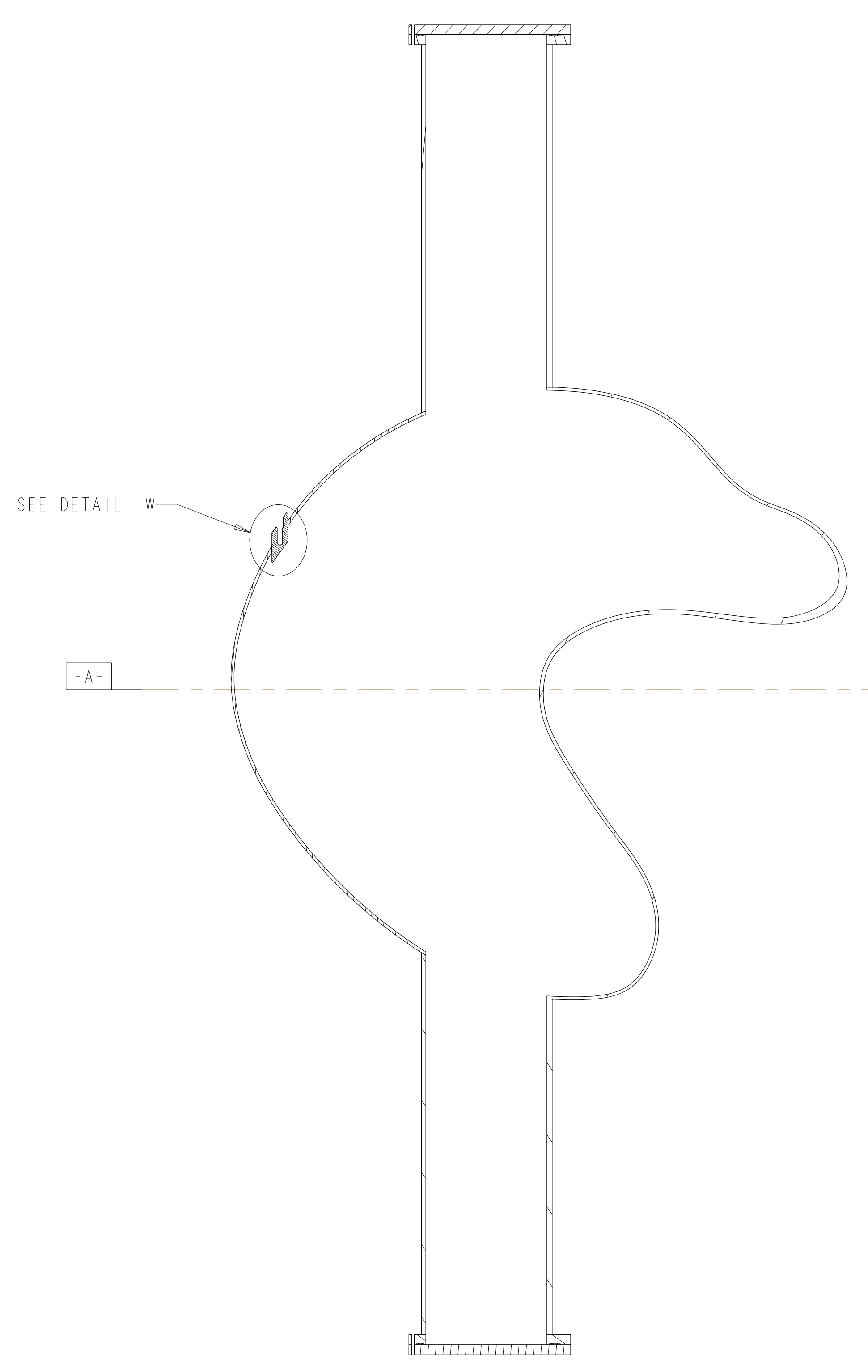

SECTION M-M
 SCALE 0.09

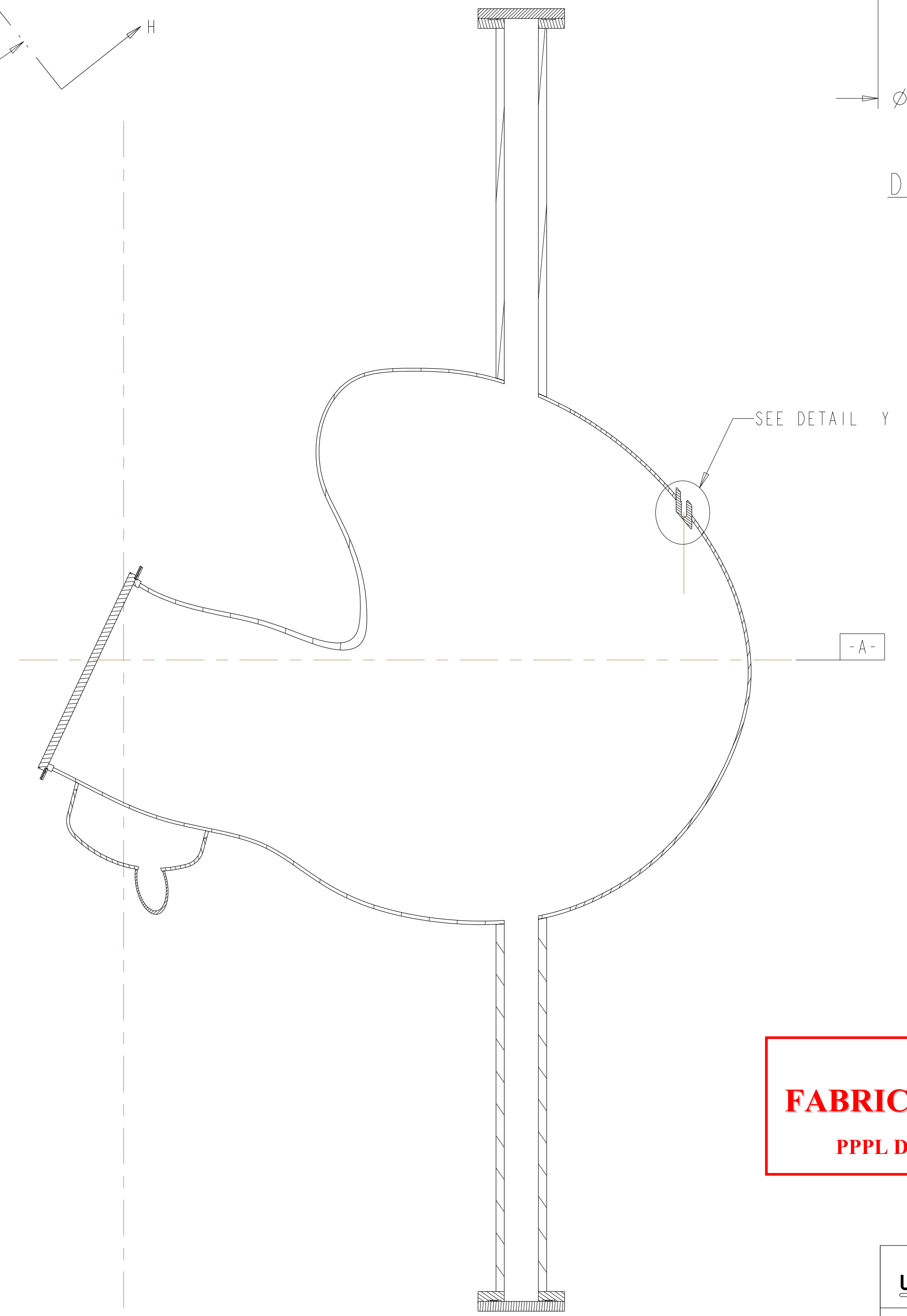

SECTION H-H
 SCALE 0.09

Rev 2-e: ECN-5021 (RFD-12-017) approved alternate methods for welding the port extensions to the VVSA (See ECN-5021 for details). - Only applicable to VVSA #3 - VVSA #1 and #2 covered by NCR 19464.

RELEASED FOR FABRICATION / INSTALLATION
 PPPL Drafting:

Oak Ridge National Laboratory managed for the DEPARTMENT OF ENERGY under U.S. GOVERNMENT CONTRACT DE-AC05-00OR22725 UT-BATTELLE, LLC. Oak Ridge, Tennessee PROJECT NAME							
NATIONAL COMPACT STELLARATOR EXPERIMENT VACUUM VESSEL PERIOD INSPECTION AND LEAK CHECK ASSEMBLY							
VERSION NO.	PLANT	BLDG	FL	SHT OF	TYPE	CLASS	
5	X-10	5700	3	19 19	A	U	
RELEASE LEVEL		SEI20-004		REV			
Fabrication				2			

H
G
F
E
D
C
B
A