

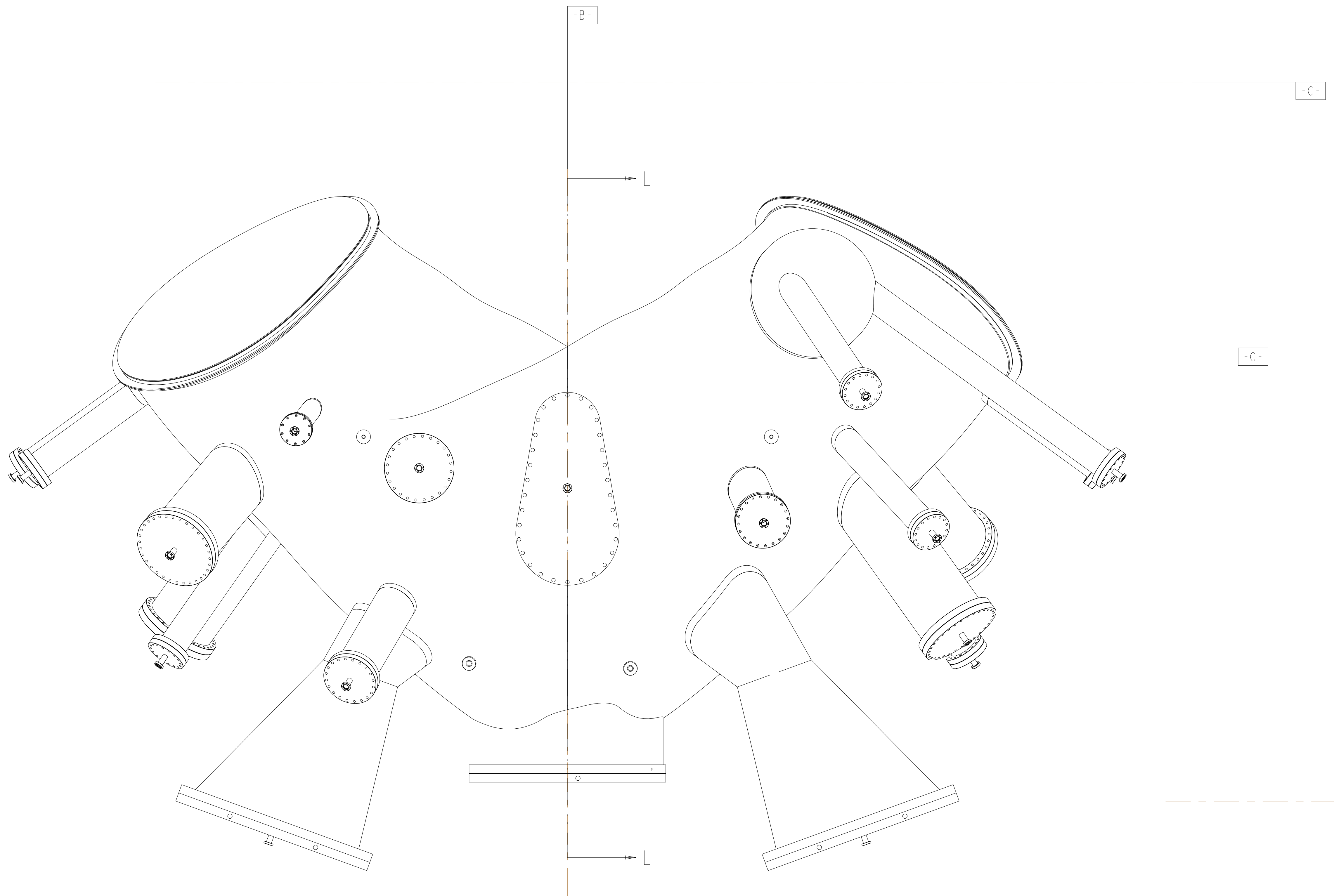

FOR NOTES AND PARTS LIST SEE SHEET 1

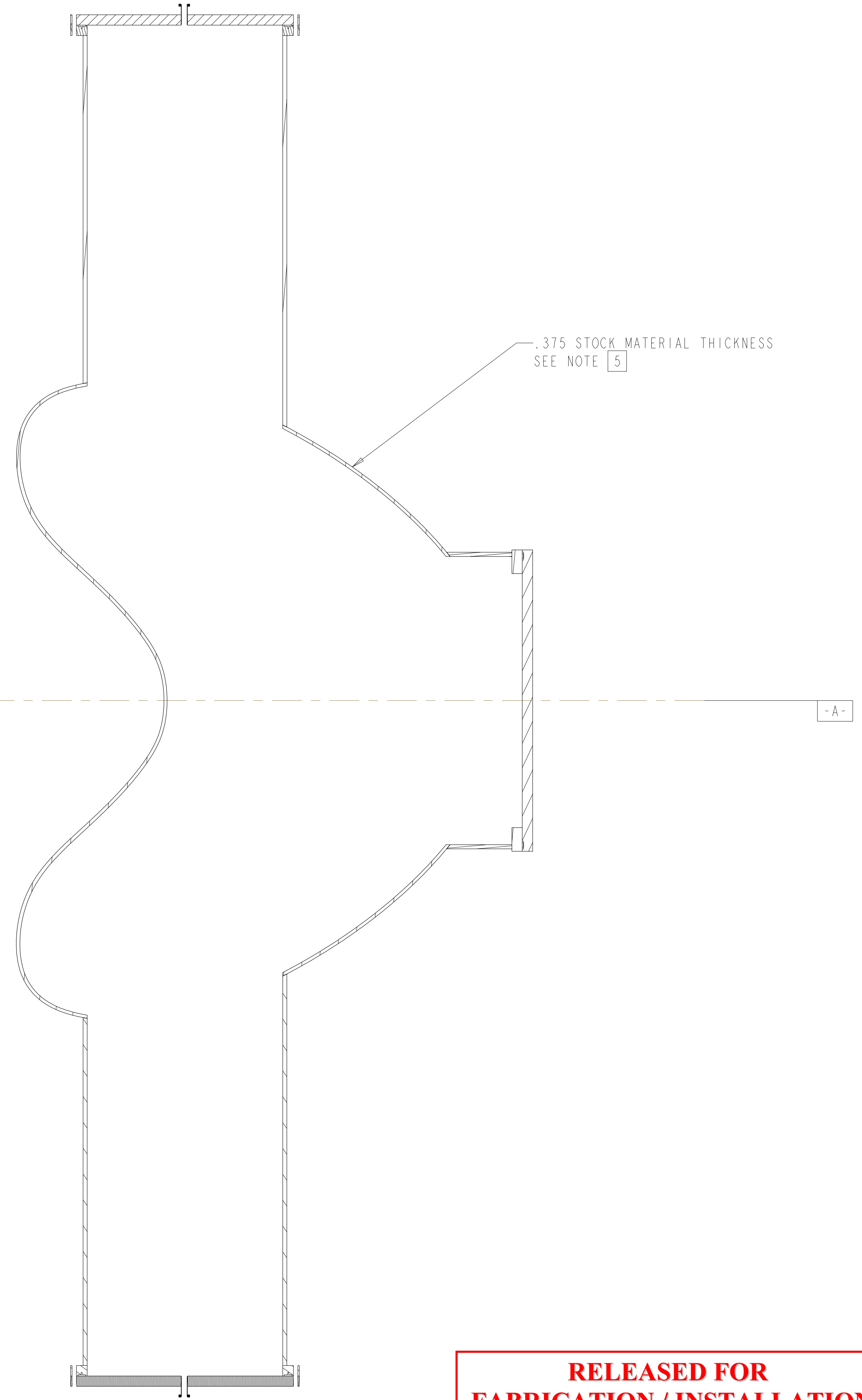

TOP VIEW



SECTION L-L  
 VESSEL THICKNESS

**RELEASED FOR  
 FABRICATION / INSTALLATION**  
 PPPL Drafting:

Oak Ridge National Laboratory managed for the DEPARTMENT OF ENERGY under U.S. GOVERNMENT contract DE-AC05-00OR22725 UT-BATTELLE, LLC, Oak Ridge, Tennessee PROJECT NAME						
NATIONAL COMPACT STELLERATOR EXPERIMENT VACUUM VESSEL PERIOD INSPECTION AND LEAK CHECK ASSEMBLY						
VERSION NO.	PLANT	BLDG	FL	SHT OF	TYPE	CLASS
5	X-10	5700	3	2 19	A	U
RELEASE LEVEL		SE120-004			REV	
Fabrication					2	

H  
G  
F  
E  
D  
C  
B  
A

FOR NOTES AND PARTS LIST SEE SHEET 1

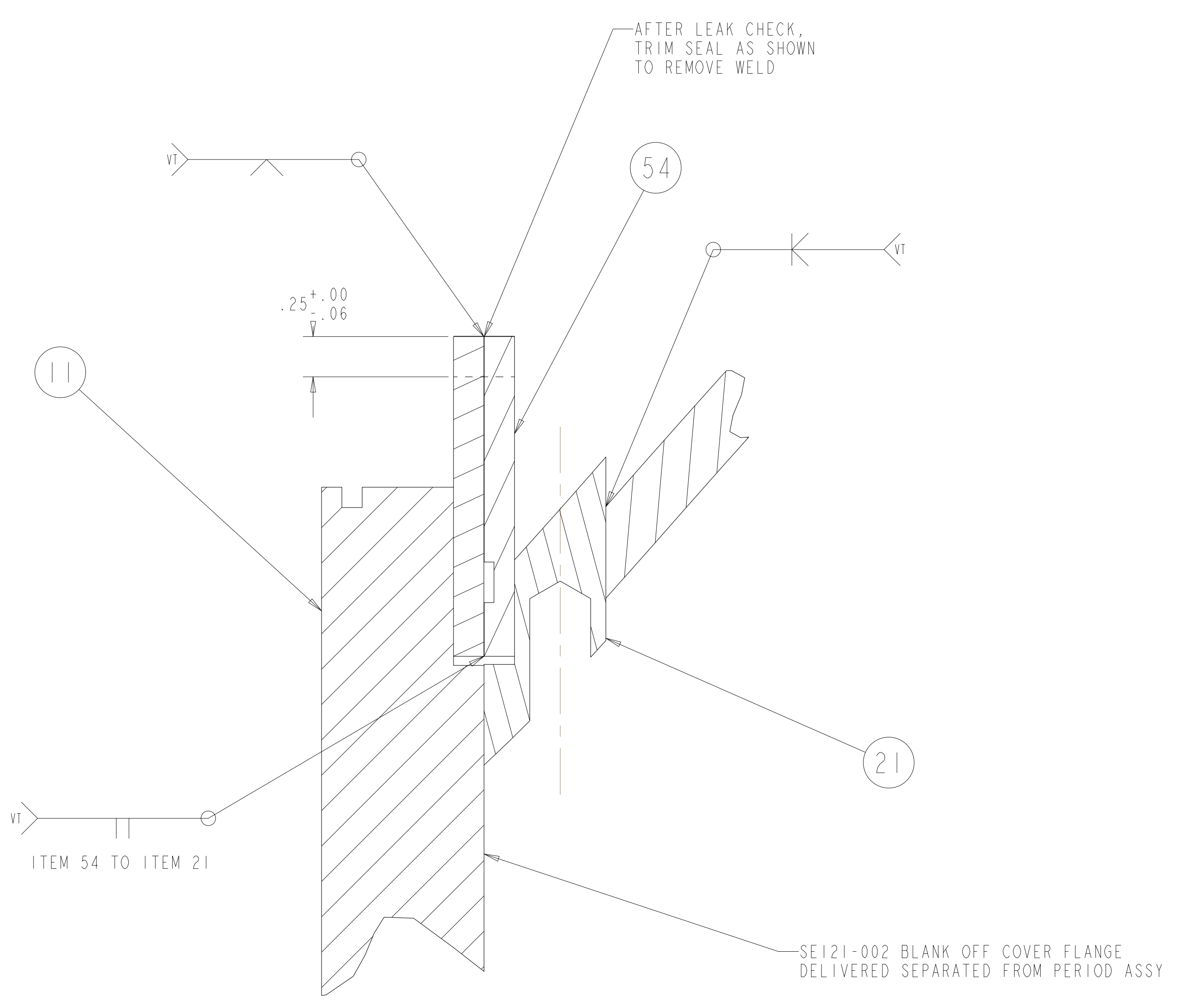
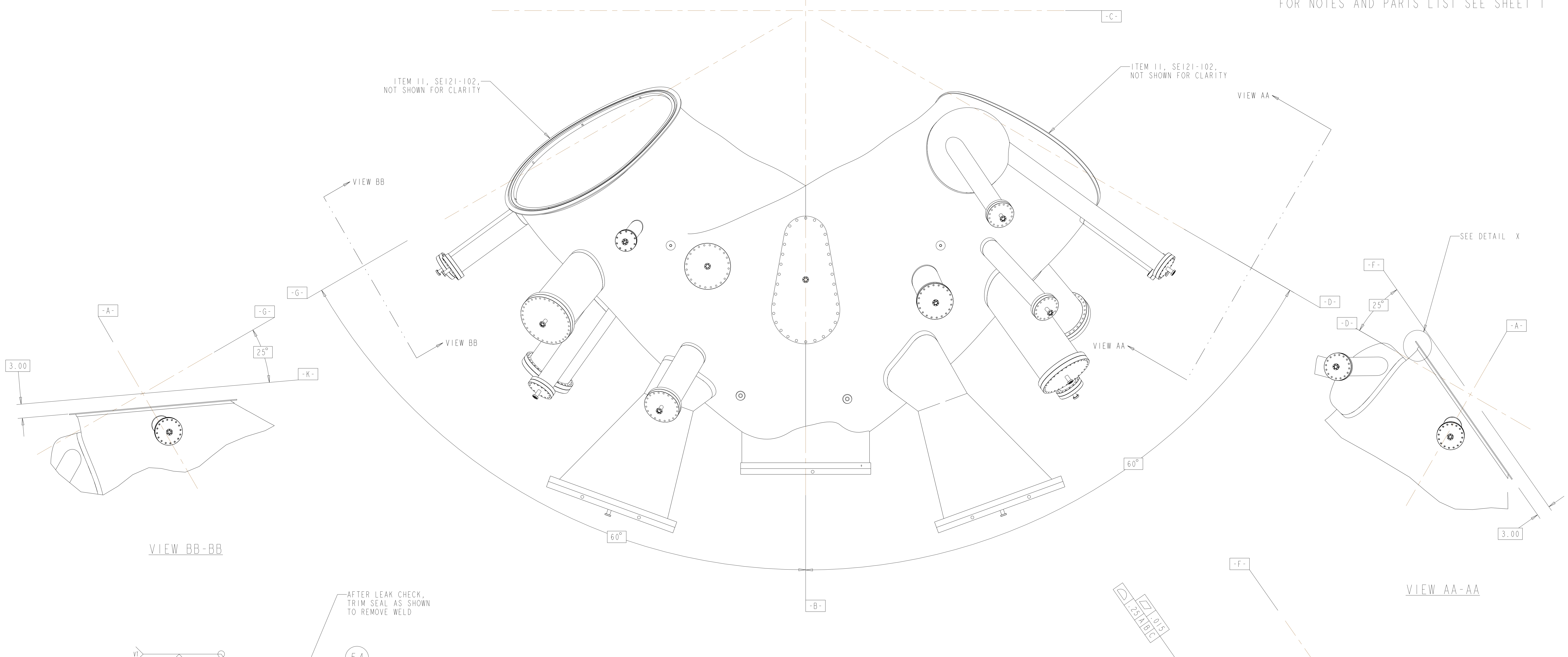

SEE DRAWING SE121-013.DRW FOR ADDITIONAL DETAILS FOR THE VACUUM VESSEL FLANGE. DIMENSIONS ON DRAWING SE121-013.DRW APPLY AS IF THEY WERE DETAILED ON THIS SHEET.

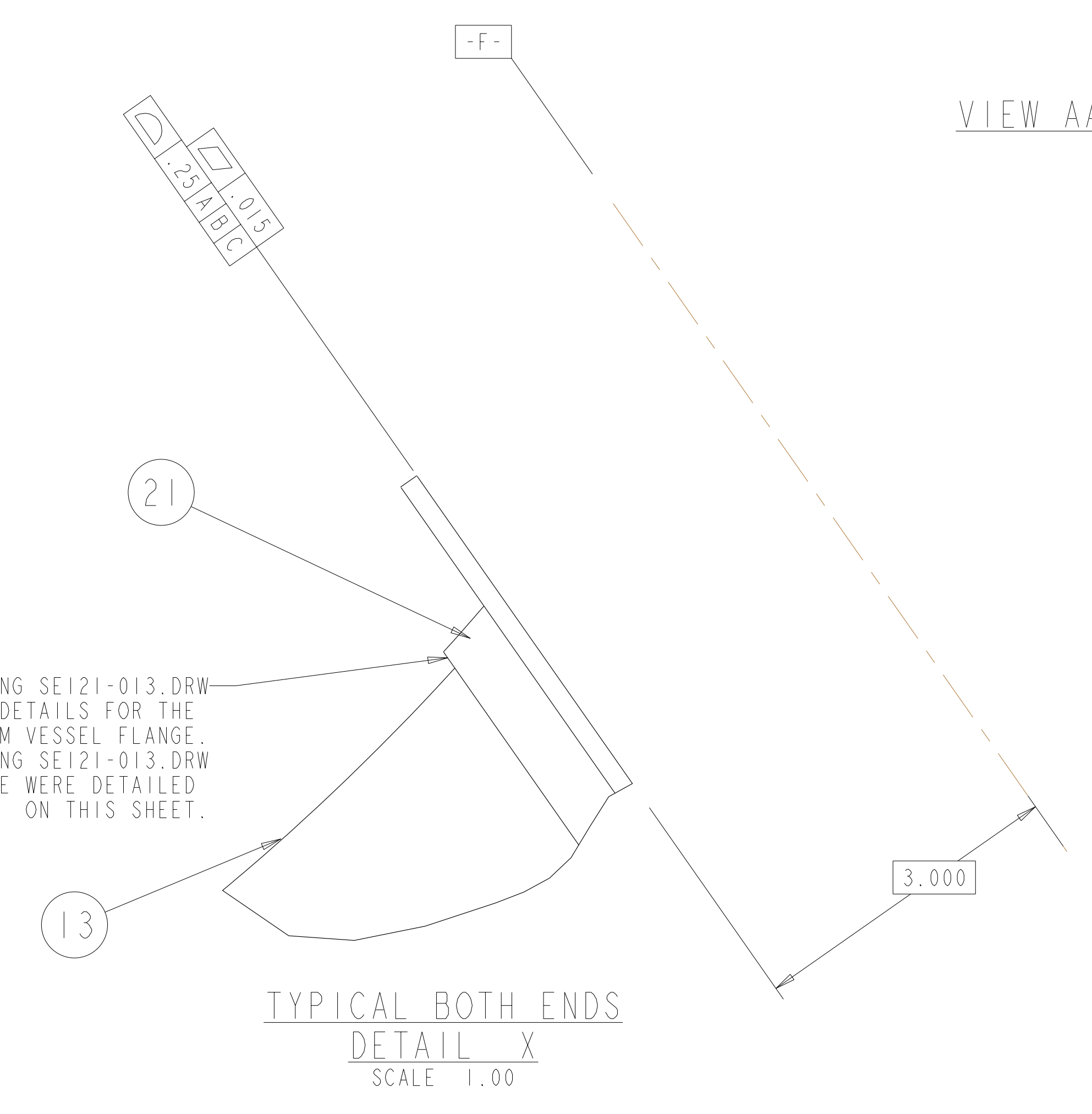

**RELEASED FOR FABRICATION / INSTALLATION**  
PPPL Drafting:

UT-BATTELLE		Oak Ridge National Laboratory managed for the DEPARTMENT OF ENERGY under U.S. GOVERNMENT contract DE-AC05-00OR22725 UT-BATTELLE, LLC, Oak Ridge, Tennessee					
PROJECT NAME							
NATIONAL COMPACT STELLARATOR EXPERIMENT							
VACUUM VESSEL							
PERIOD INSPECTION AND LEAK CHECK							
ASSEMBLY							
VERSION NO.	PLANT	BLDG	FL	SHT OF	TYPE	CLASS	
5	X-10	5700	3	3 19	A	U	
RELEASE LEVEL	Fabrication					SE120-004	REV 2

FOR PARTS LIST AND NOTES SEE SHEET 1.

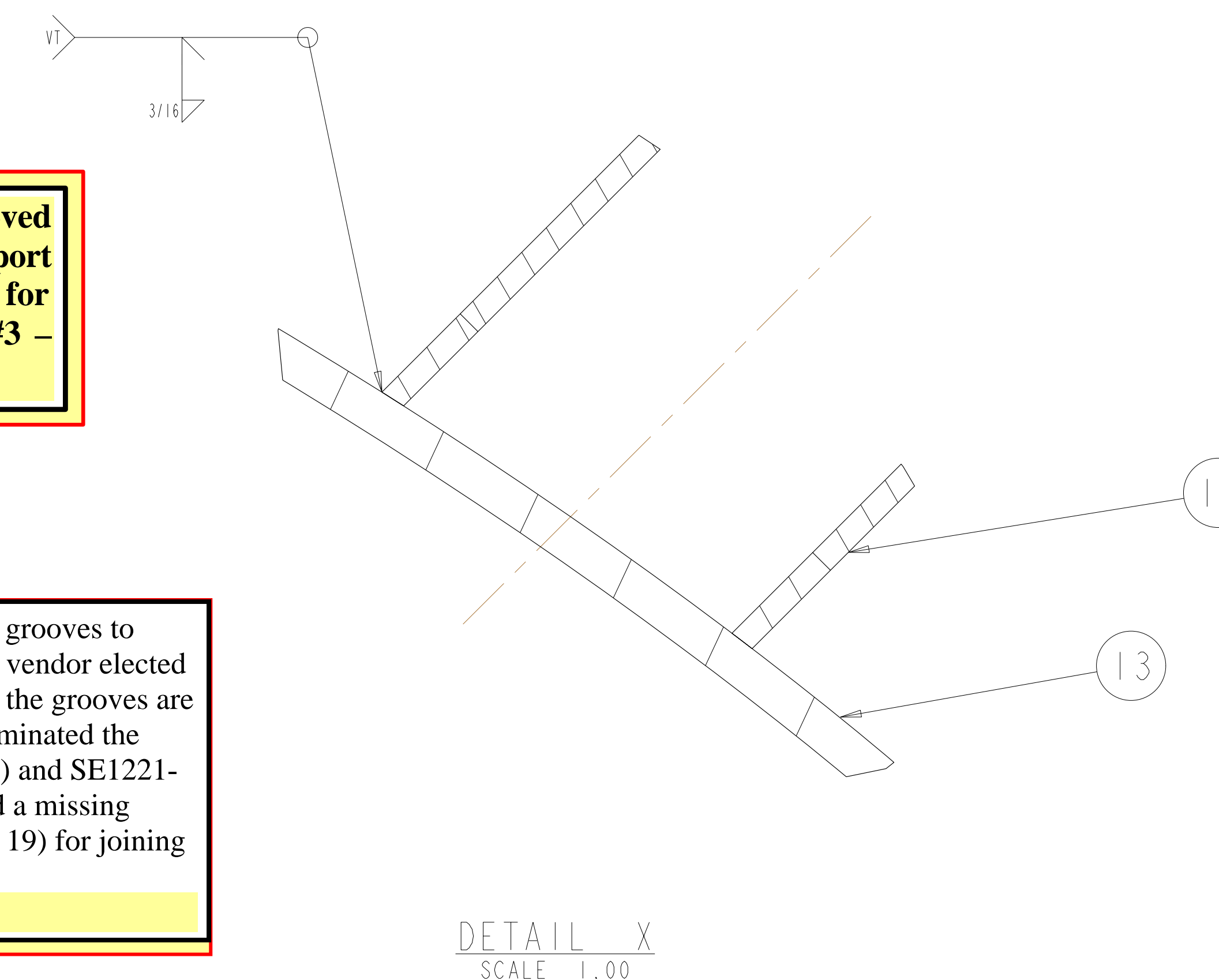
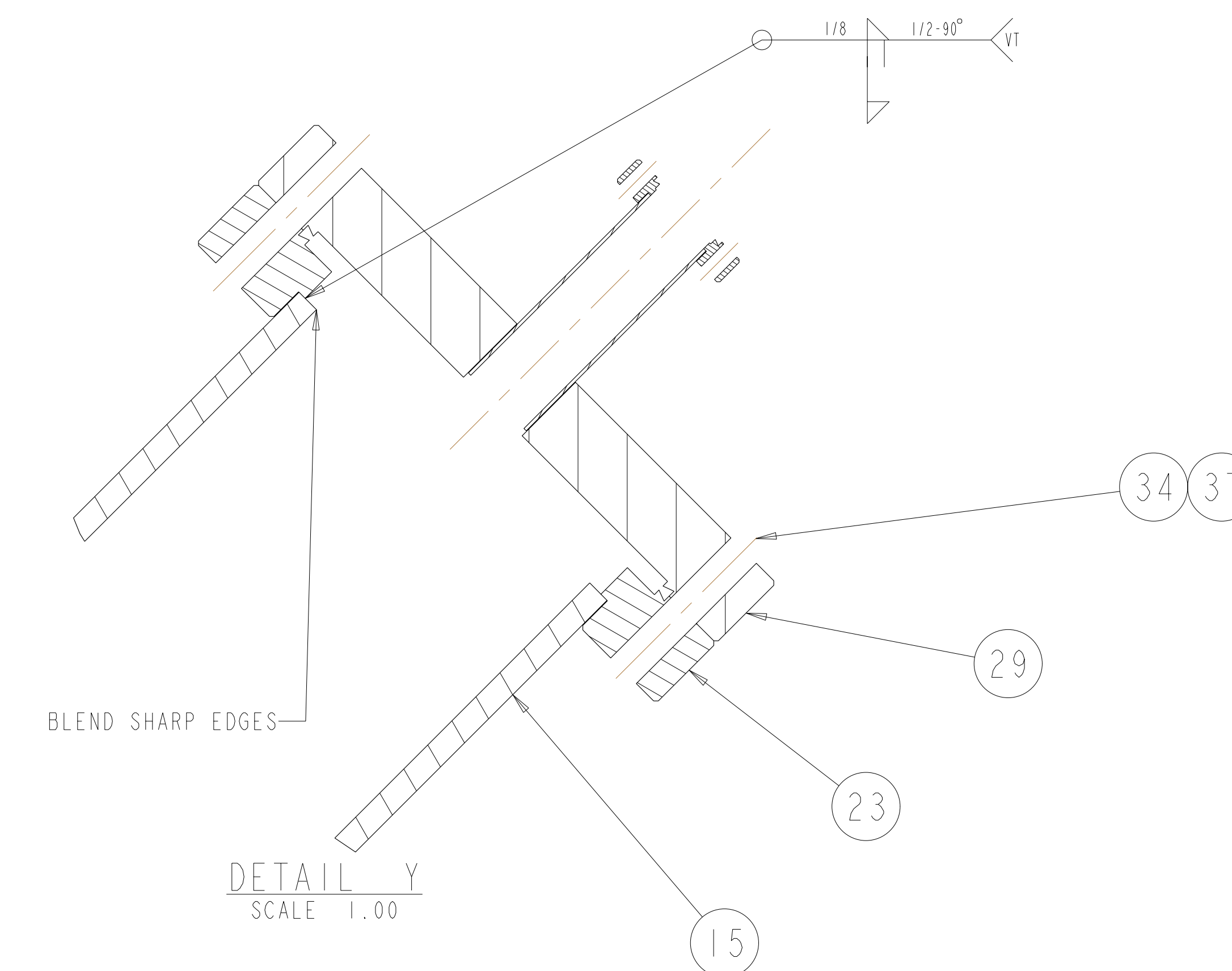
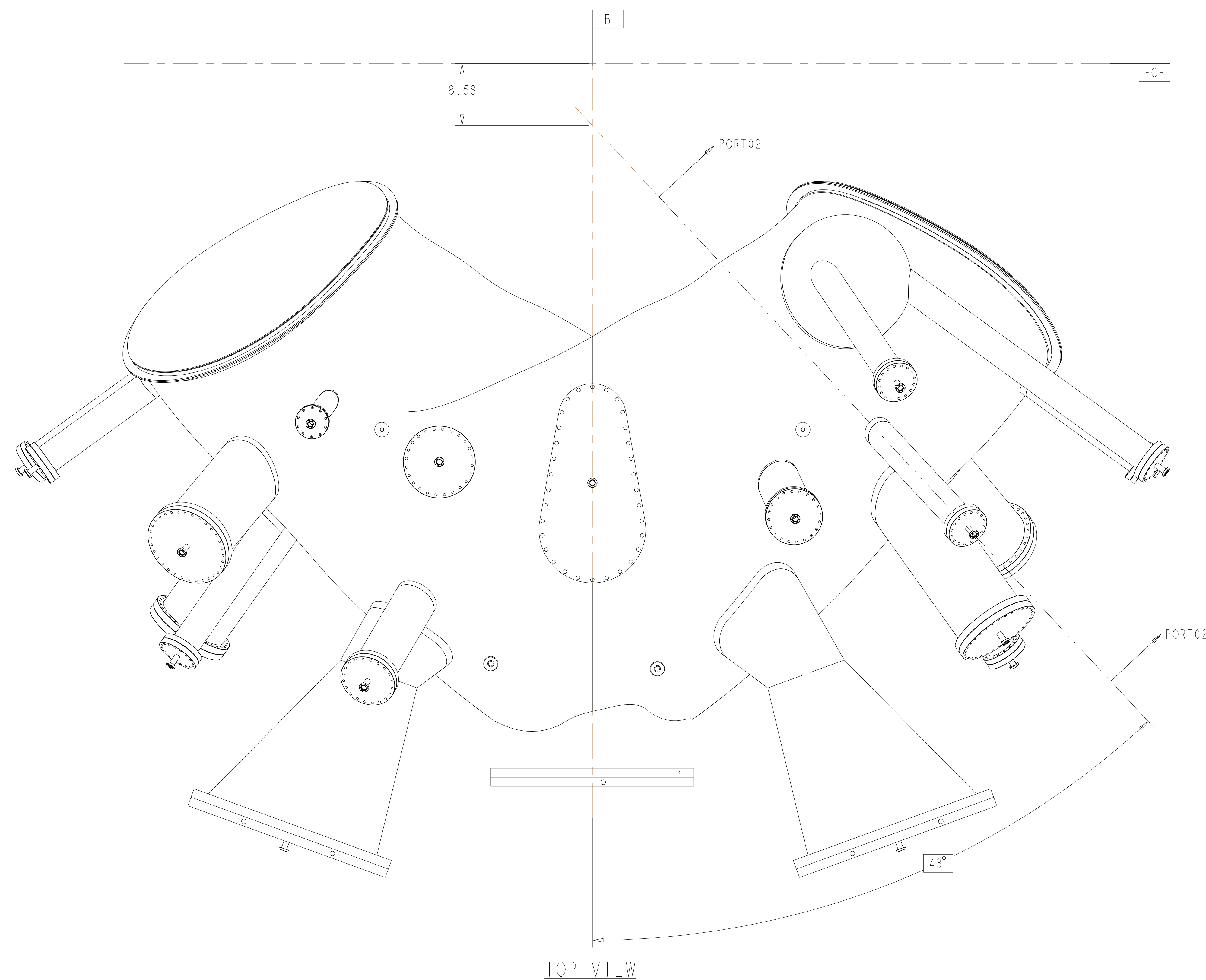

**Rev 2-e: ECN-5021 (RFD-12-017) approved alternate methods for welding the port extensions to the VVSA (See ECN-5021 for details). - Only applicable to VVSA #3 - VVSA #1 and #2 covered by NCR 19464.**

**ECN-5082.** Requirement originally included grooves to facilitate leak checking by vendor. However, vendor elected another means of leak checking and therefore the grooves are no longer required. Specifically, this ECN eliminated the leak checking groove on SE121-014 (Rev 1-c) and SE1221-091 (Rev 0-a). Additionally, this ECN added a missing weld symbol to SE121-004 (Sheets 4 through 19) for joining the port extensions to the vessel (Rev 2-d).  
(See ECN-5082 for details)

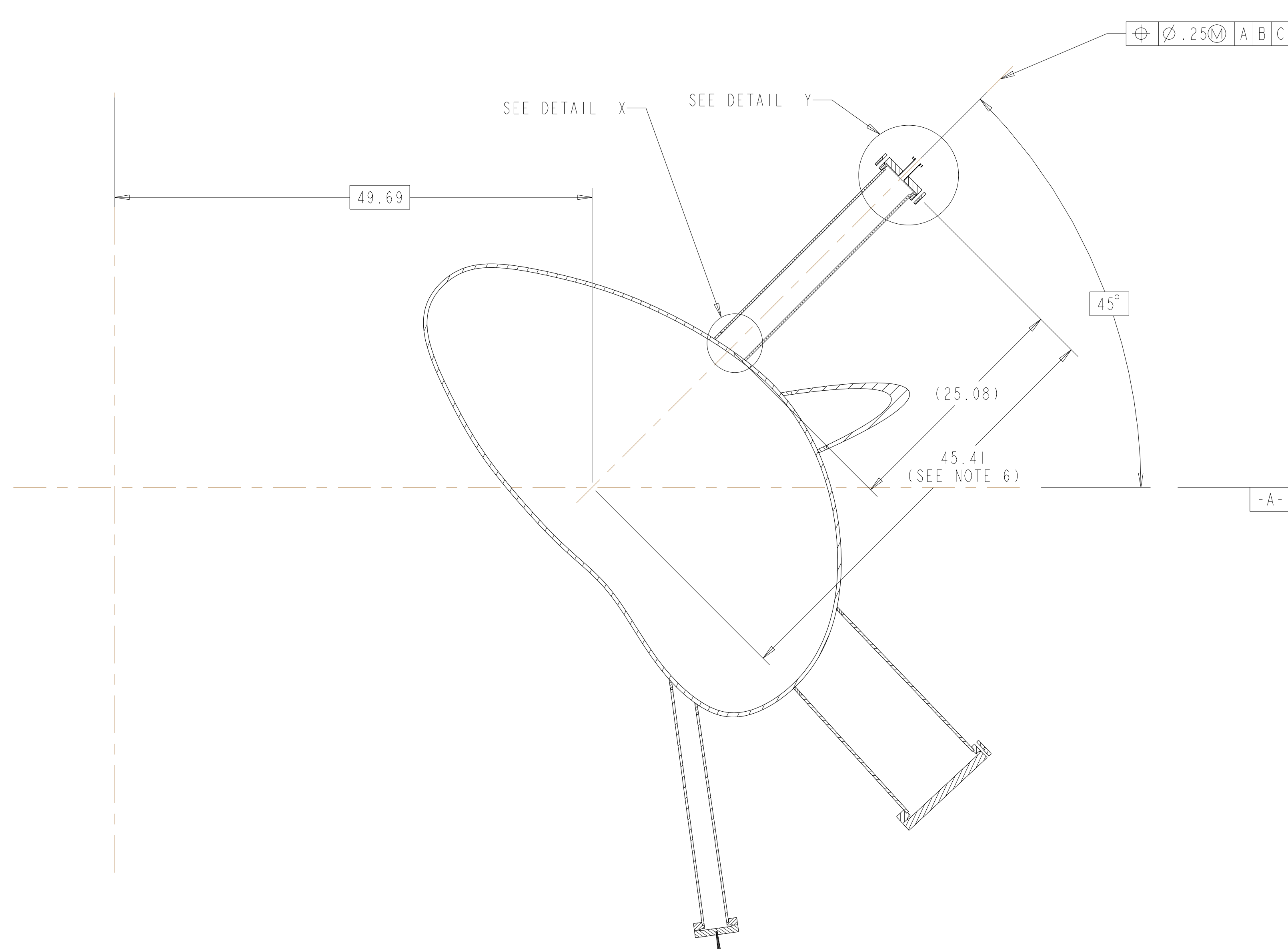

TYPICAL PORT 2A AND 2B SECTION PORT02-PORT02

**RELEASED FOR FABRICATION / INSTALLATION**  
PPPL Drafting:

UT-BATTELLE		Oak Ridge National Laboratory managed for the DEPARTMENT OF ENERGY under U.S. GOVERNMENT contract DE-AC05-00OR22725 UT-BATTELLE, LLC, Oak Ridge, Tennessee						
PROJECT NAME								
NATIONAL COMPACT STELLARATOR EXPERIMENT								
VACUUM VESSEL								
PERIOD INSPECTION AND LEAK CHECK ASSEMBLY								
VERSION NO.	PLANT	BLDG	FL	SHT OF	TYPE	CLASS		
5	X-10	5700	3	4	19	A	U	
RELEASE LEVEL		SE120-004					REV	2
Fabrication								

FOR PARTS LIST AND NOTES SEE SHEET 1.

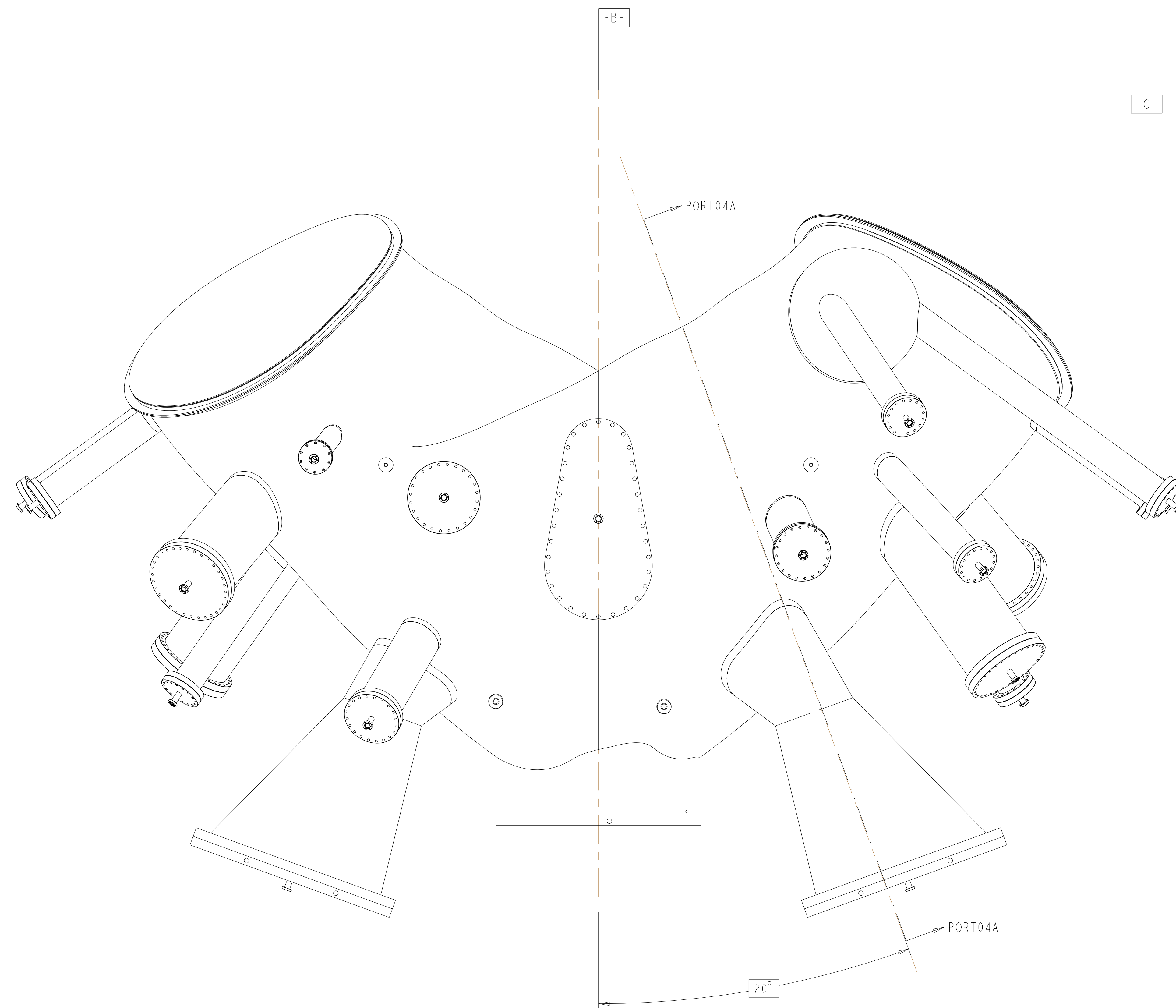

TOP VIEW

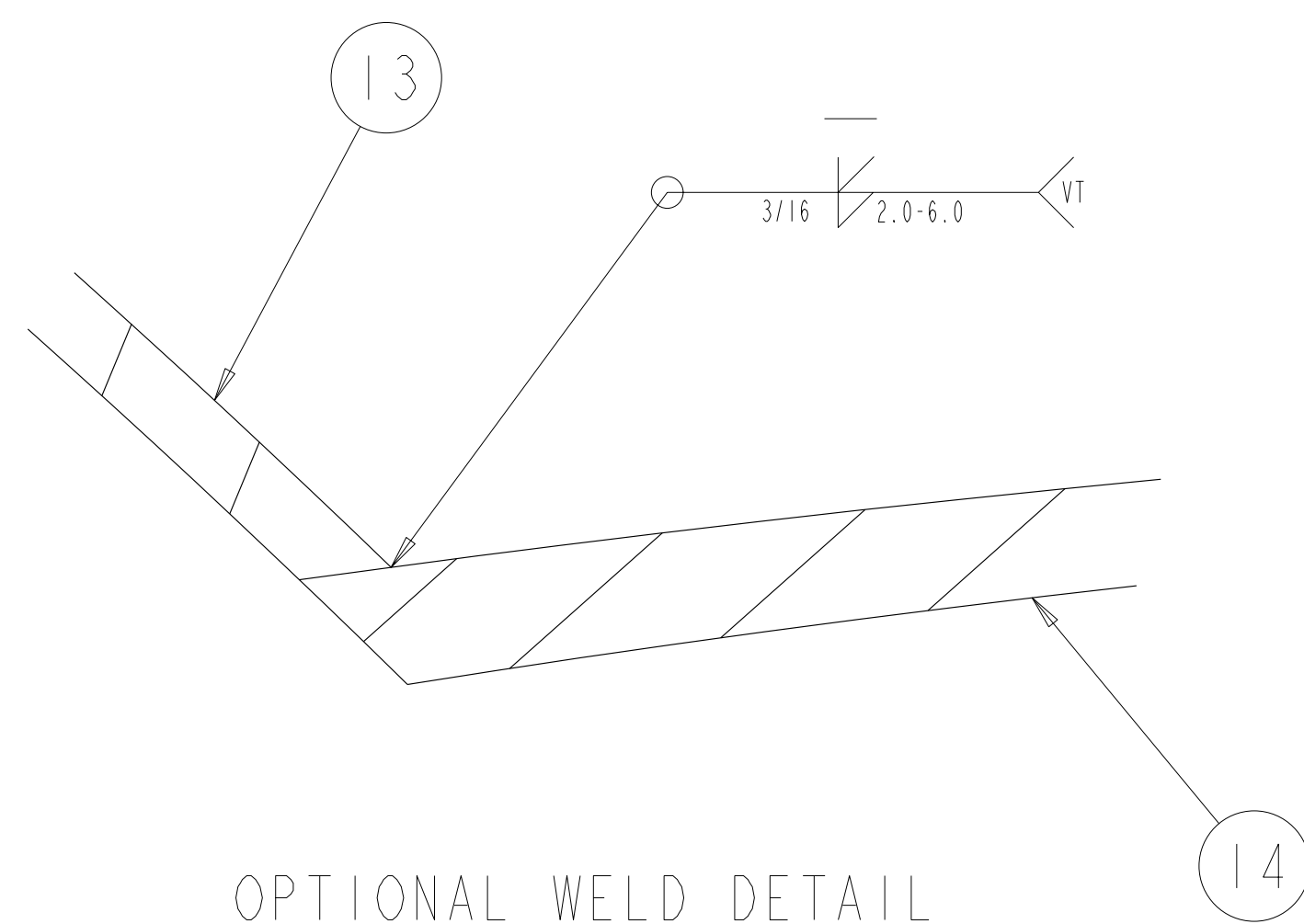

OPTIONAL WELD DETAIL

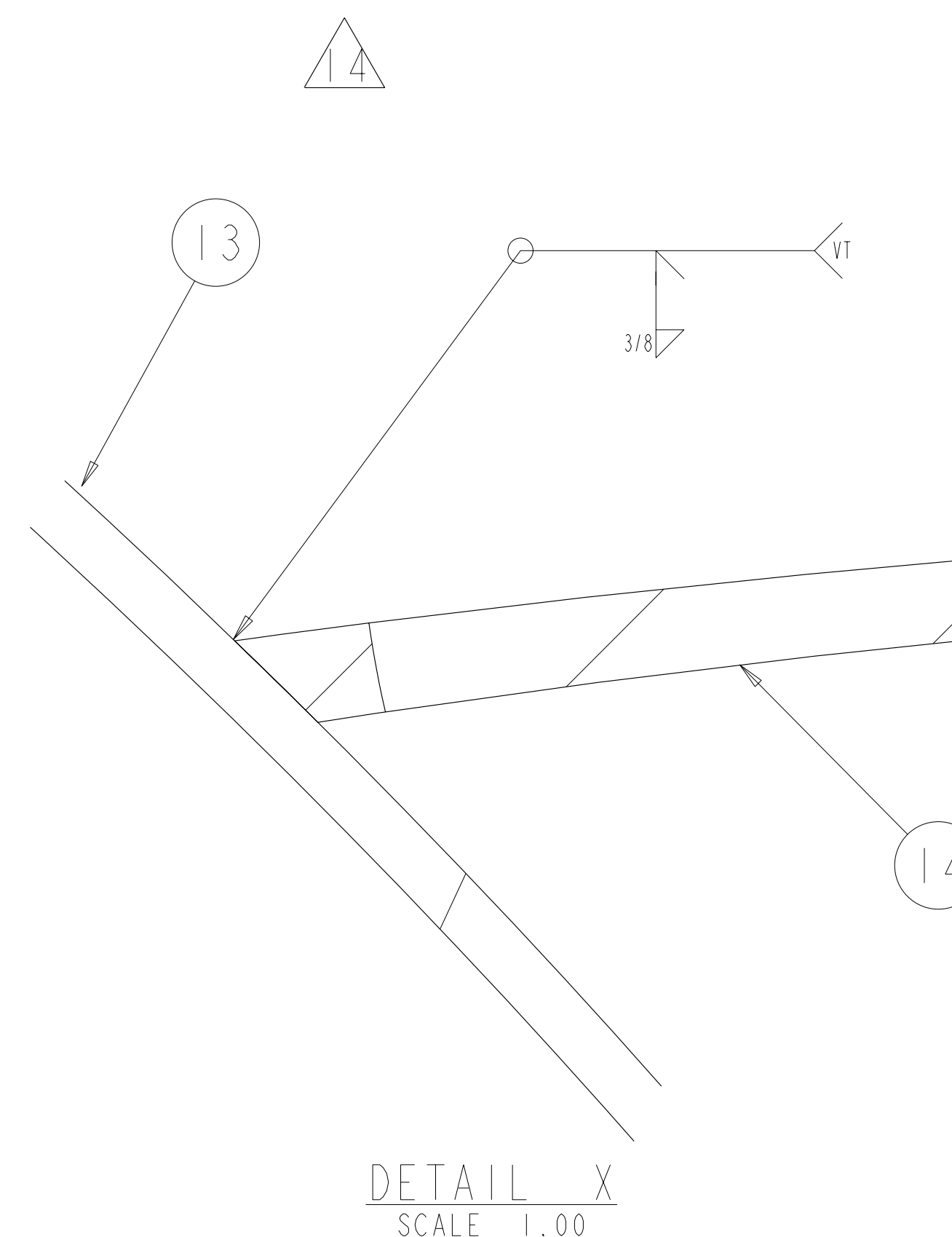

DETAIL X  
SCALE 1.00

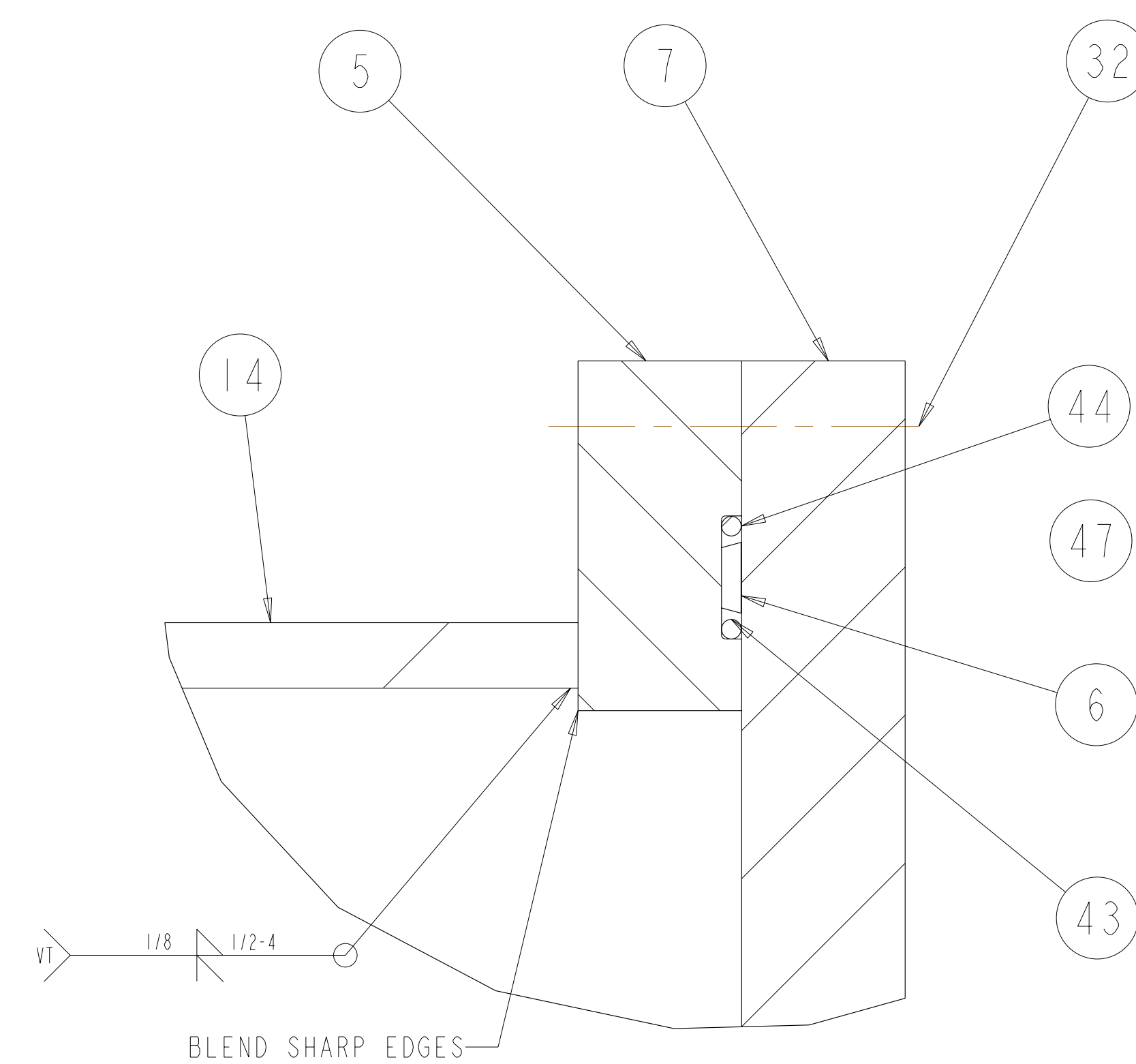

DETAIL Y  
SCALE 1.00

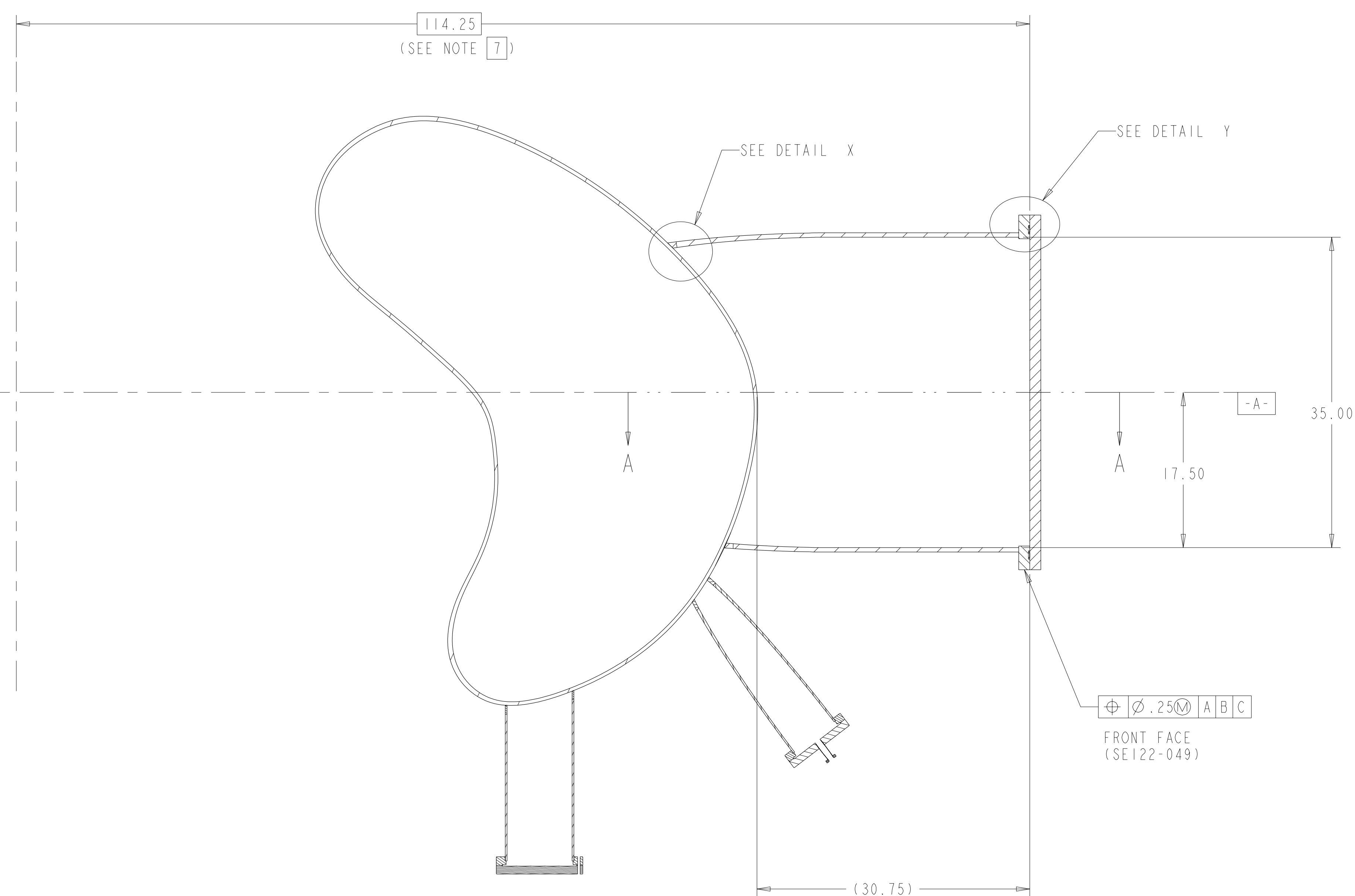

TYPICAL PORT 4A AND 4B  
SECTION PORT04A-PORT04A

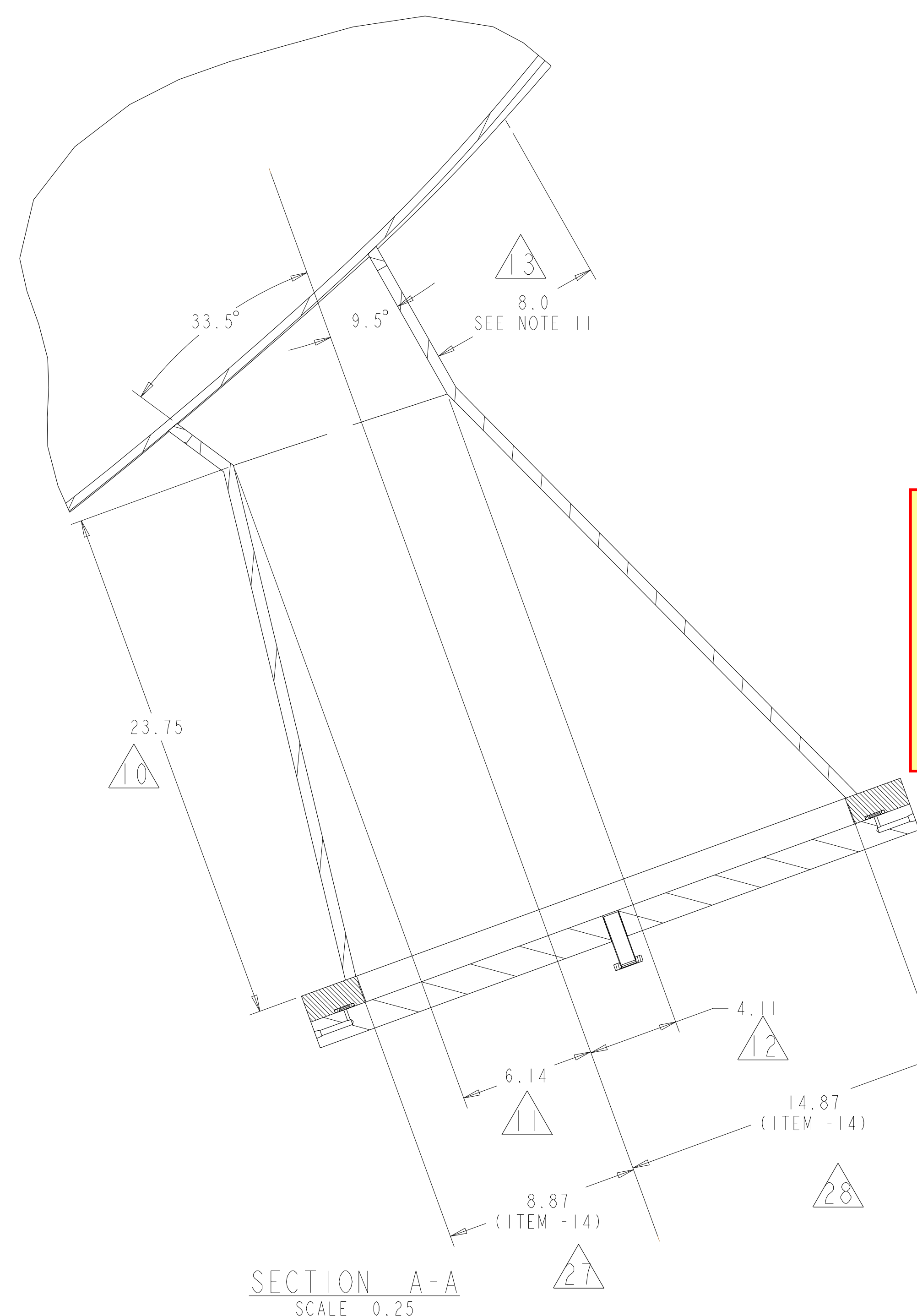

SECTION A-A  
SCALE 0.25

**Rev 2-e: ECN-5021 (RFD-12-017) approved alternate methods for welding the port extensions to the VVSA (See ECN-5021 for details). - Only applicable to VVSA #3 - VVSA #1 and #2 covered by NCR 19464.**

**ECN-5082.** Requirement originally included grooves to facilitate leak checking by vendor. However, vendor elected another means of leak checking and therefore the grooves are no longer required. Specifically, this ECN eliminated the leak checking groove on SE121-014 (Rev 1-c) and SE1221-091 (Rev 0-a). Additionally, this ECN added a missing weld symbol to SE121-004 (Sheets 4 through 19) for joining the port extensions to the vessel (Rev 2-d).  
**(See ECN-5082 for details)**

**RELEASED FOR FABRICATION / INSTALLATION**  
PPPL Drafting:

UT-BATTELLE		Oak Ridge National Laboratory managed for the DEPARTMENT OF ENERGY under U.S. GOVERNMENT contract DE-AC05-00OR22725 UT-BATTELLE, LLC. Oak Ridge, Tennessee	
PROJECT NAME			
NATIONAL COMPACT STELLERATOR EXPERIMENT			
VACUUM VESSEL			
PERIOD INSPECTION AND LEAK CHECK ASSEMBLY			
VERSION NO.	PLANT	BLDG	FL
5	X-10	5700	3
RELEASE LEVEL			
Fabrication			
SHT OF	TYPE	CLASS	
5	A	U	
REV			
2			

FOR PARTS LIST AND NOTES SEE SHEET 1.

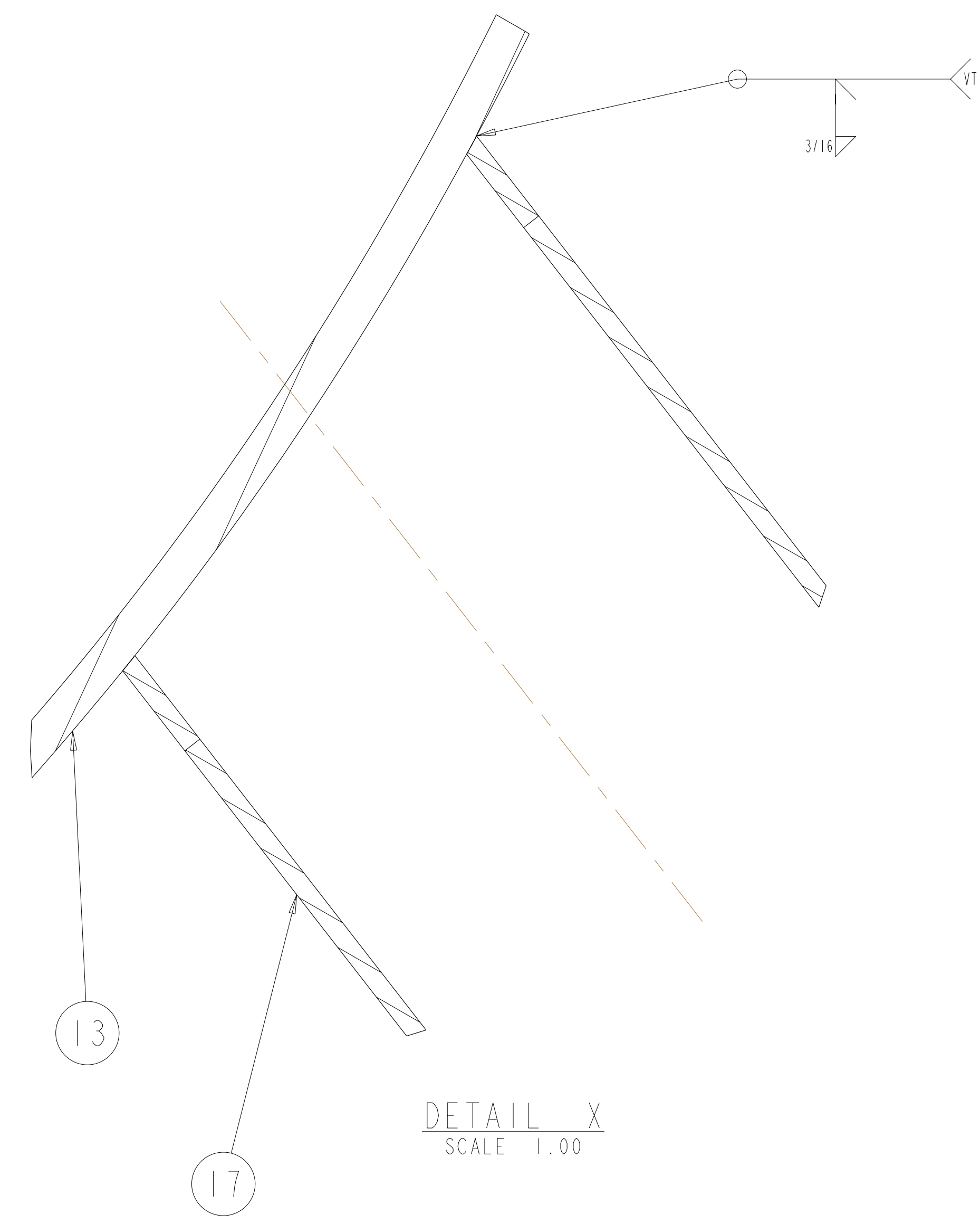
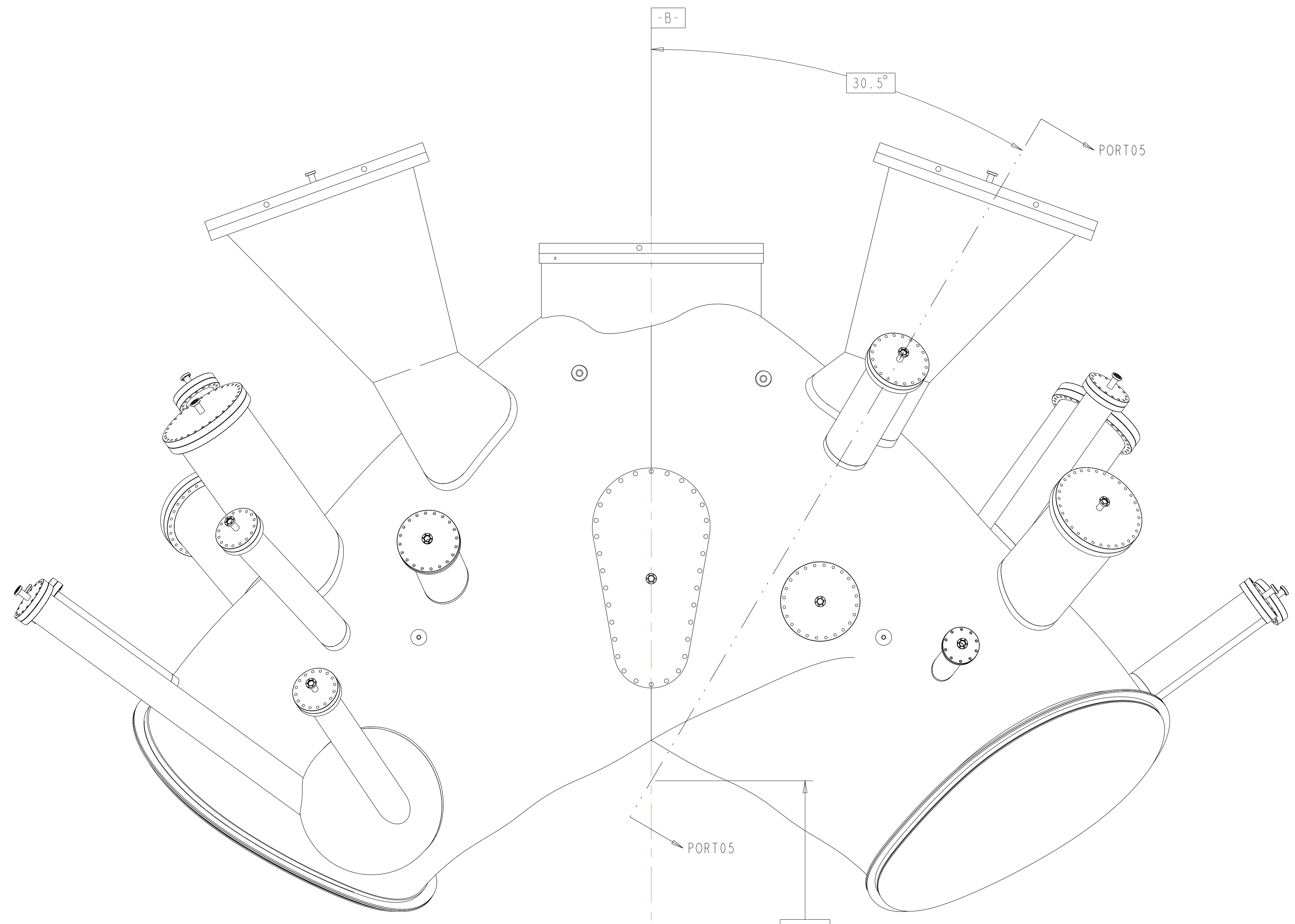

**Rev 2-e: ECN-5021 (RFD-12-017) approved alternate methods for welding the port extensions to the VVSA (See ECN-5021 for details). - Only applicable to VVSA #3 - VVSA #1 and #2 covered by NCR 19464.**

**ECN-5082.** Requirement originally included grooves to facilitate leak checking by vendor. However, vendor elected another means of leak checking and therefore the grooves are no longer required. Specifically, this ECN eliminated the leak checking groove on SE121-014 (Rev 1-c) and SE1221-091 (Rev 0-a). Additionally, this ECN added a missing weld symbol to SE121-004 (Sheets 4 through 19) for joining the port extensions to the vessel (Rev 2-d).  
(See ECN-5082 for details)

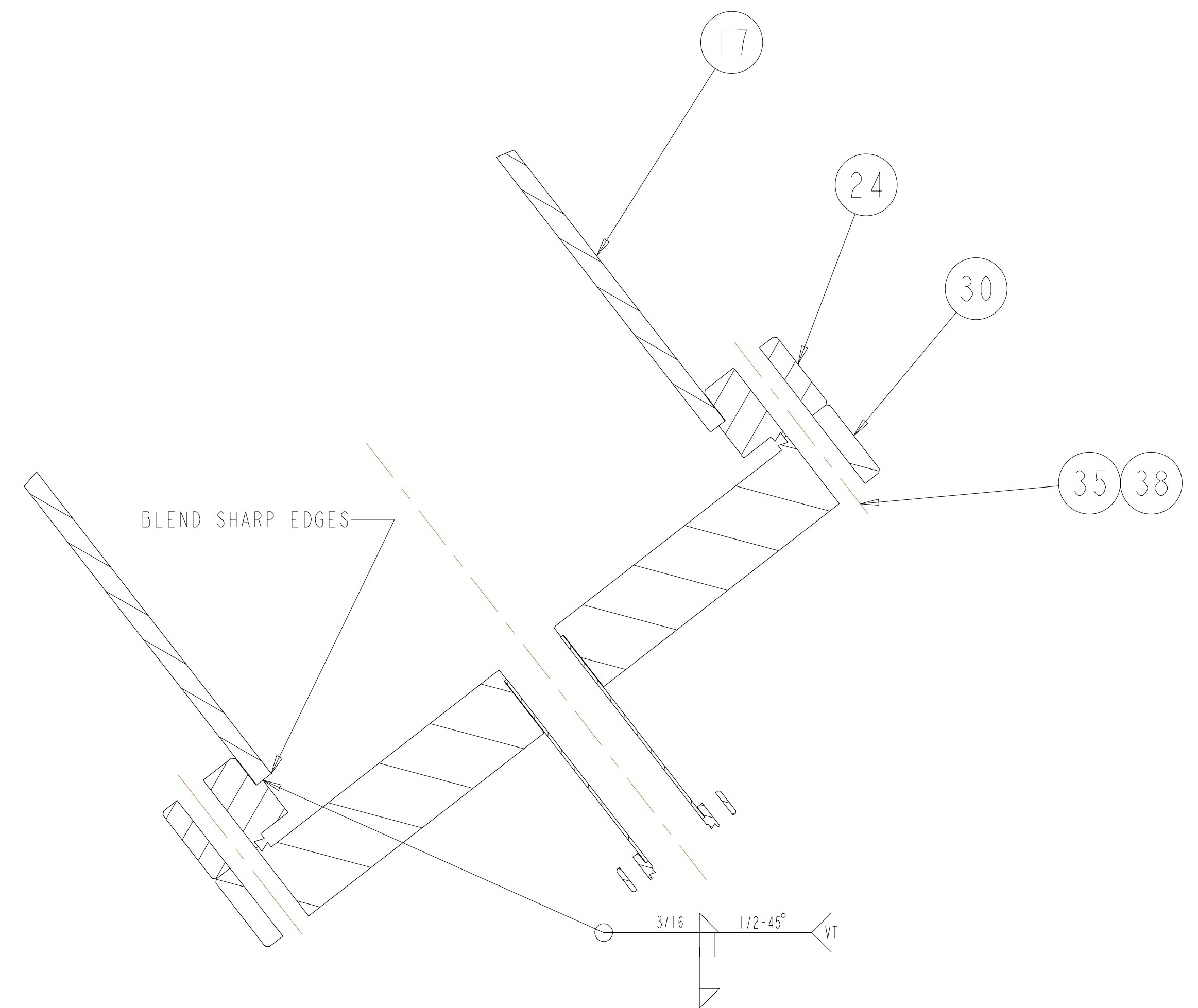

**RELEASED FOR FABRICATION / INSTALLATION**  
 PPPL Drafting:

BOTTOM VIEW

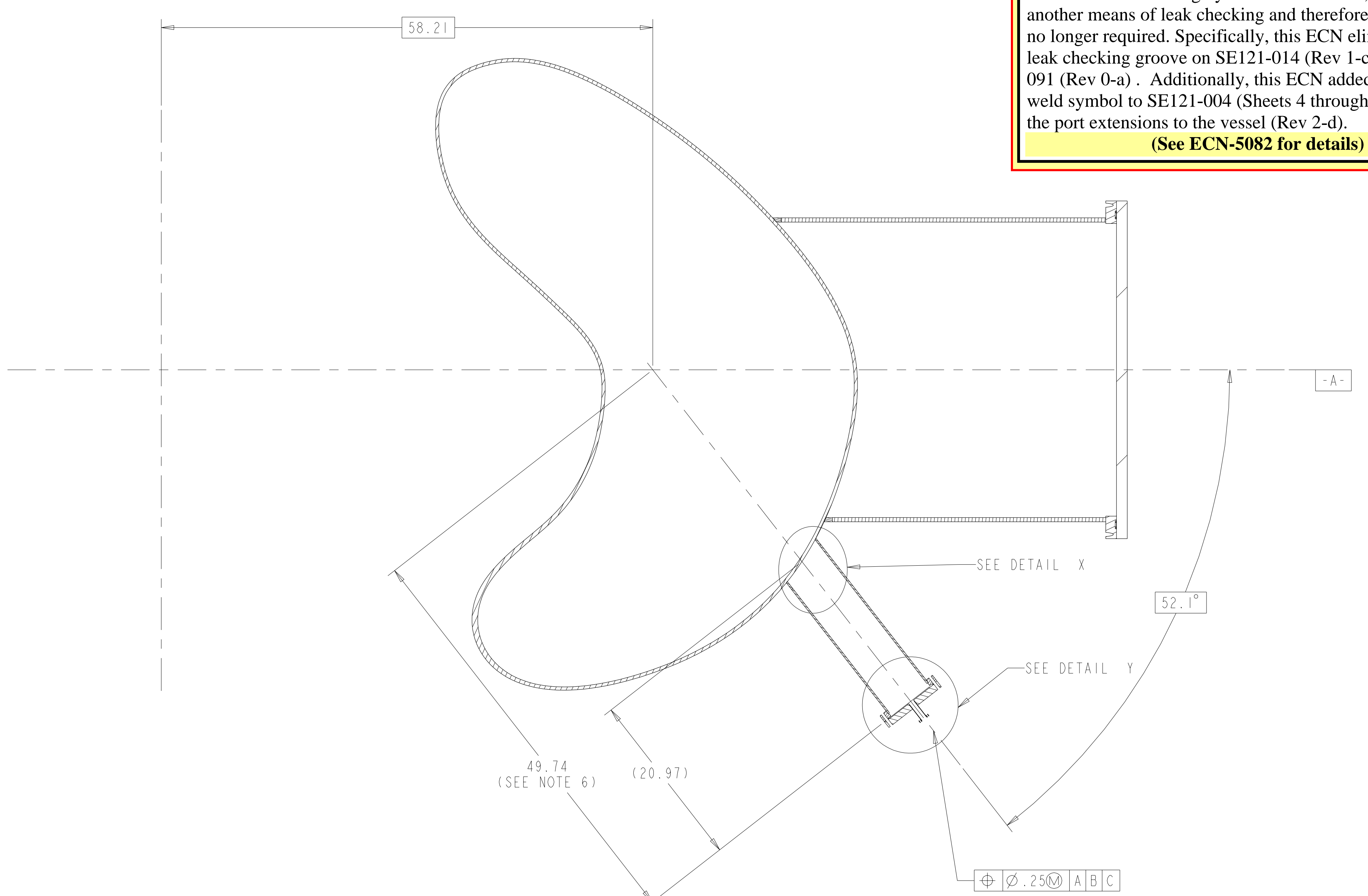

UT-BATTELLE		Oak Ridge National Laboratory managed for the DEPARTMENT OF ENERGY under U.S. GOVERNMENT contract DE-AC05-00OR22725 UT-BATTELLE, LLC, Oak Ridge, Tennessee					
NATIONAL COMPACT STELLARATOR EXPERIMENT							
VACUUM VESSEL							
PERIOD INSPECTION AND LEAK CHECK ASSEMBLY							
VERSION NO.	PLANT	BLDG	FL	SHT OF	TYPE	CLASS	
5	X-10	5700	3	6	19	A	U
RELEASE LEVEL	SE120-004						REV
Fabrication							2

H  
G  
F  
E  
D  
C  
B  
A

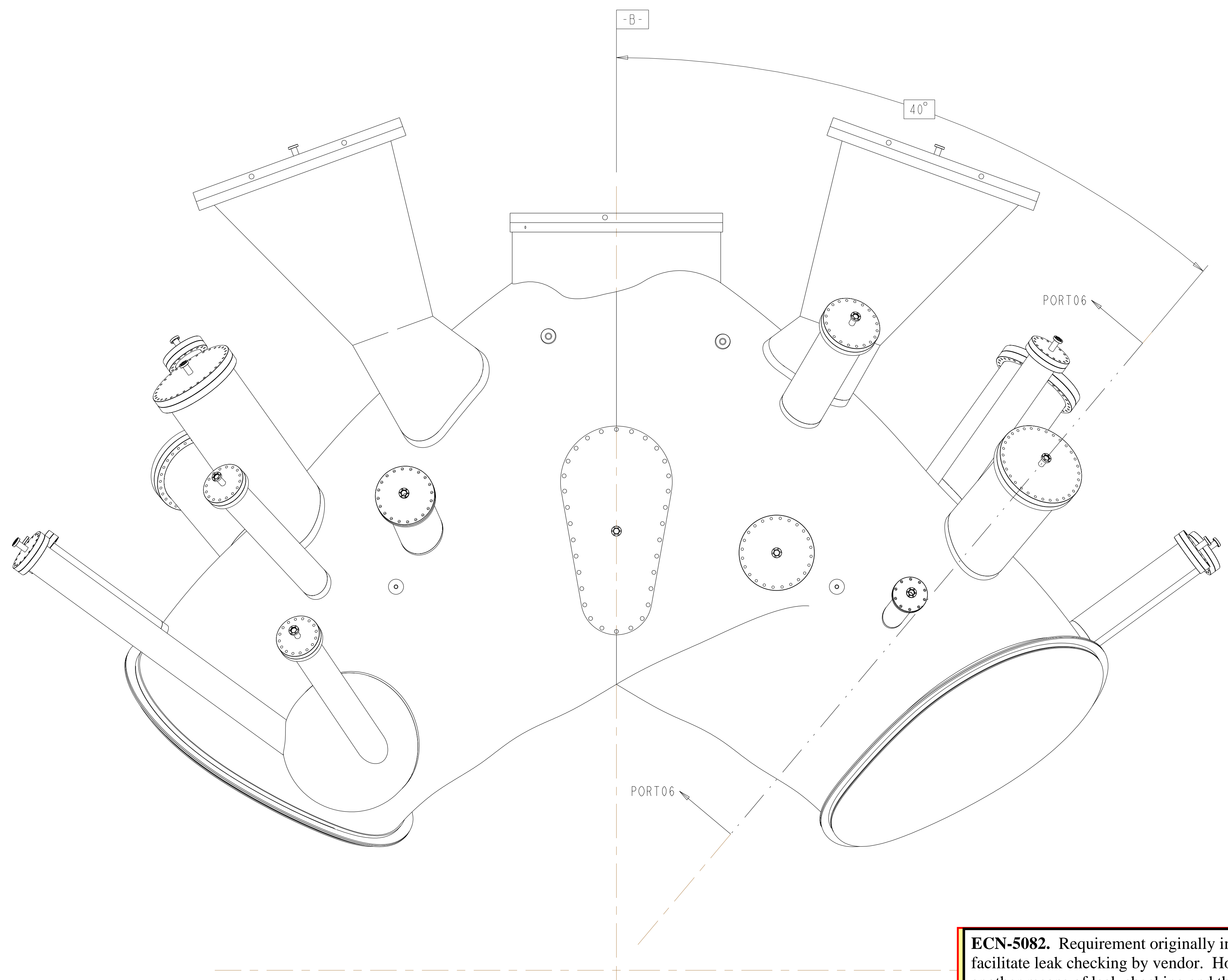

BOTTOM VIEW



DETAIL X  
SCALE 1.00

**ECN-5082.** Requirement originally included grooves to facilitate leak checking by vendor. However, vendor elected another means of leak checking and therefore the grooves are no longer required. Specifically, this ECN eliminated the leak checking groove on SE121-014 (Rev 1-c) and SE1221-091 (Rev 0-a). Additionally, this ECN added a missing weld symbol to SE121-004 (Sheets 4 through 19) for joining the port extensions to the vessel (Rev 2-d).  
 (See ECN-5082 for details)

**Rev 2-e: ECN-5021 (RFD-12-017) approved alternate methods for welding the port extensions to the VVSA (See ECN-5021 for details). - Only applicable to VVSA #3 - VVSA #1 and #2 covered by NCR 19464.**

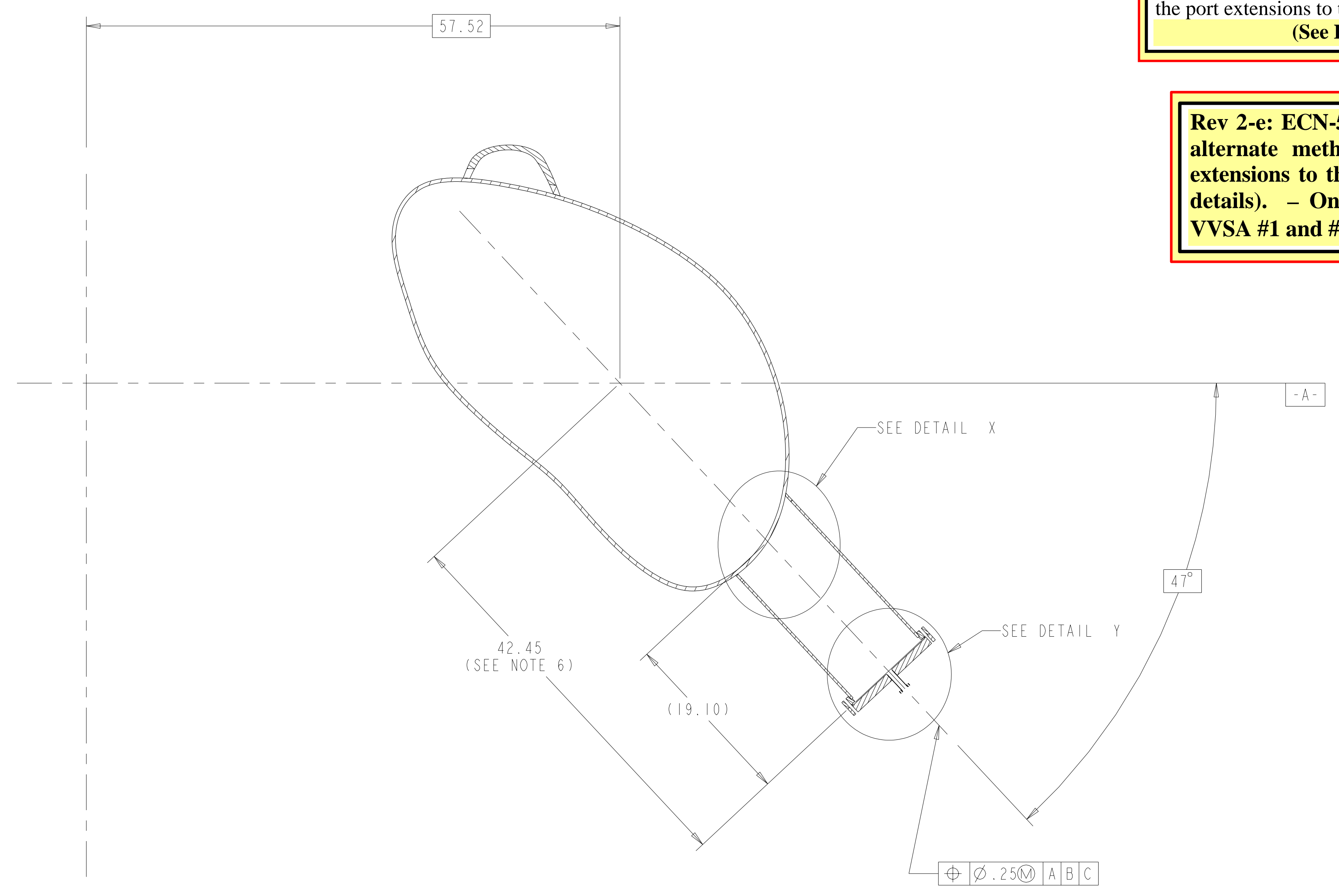

TYPICAL PORT 6A AND 6B  
SECTION PORT06-PORT06

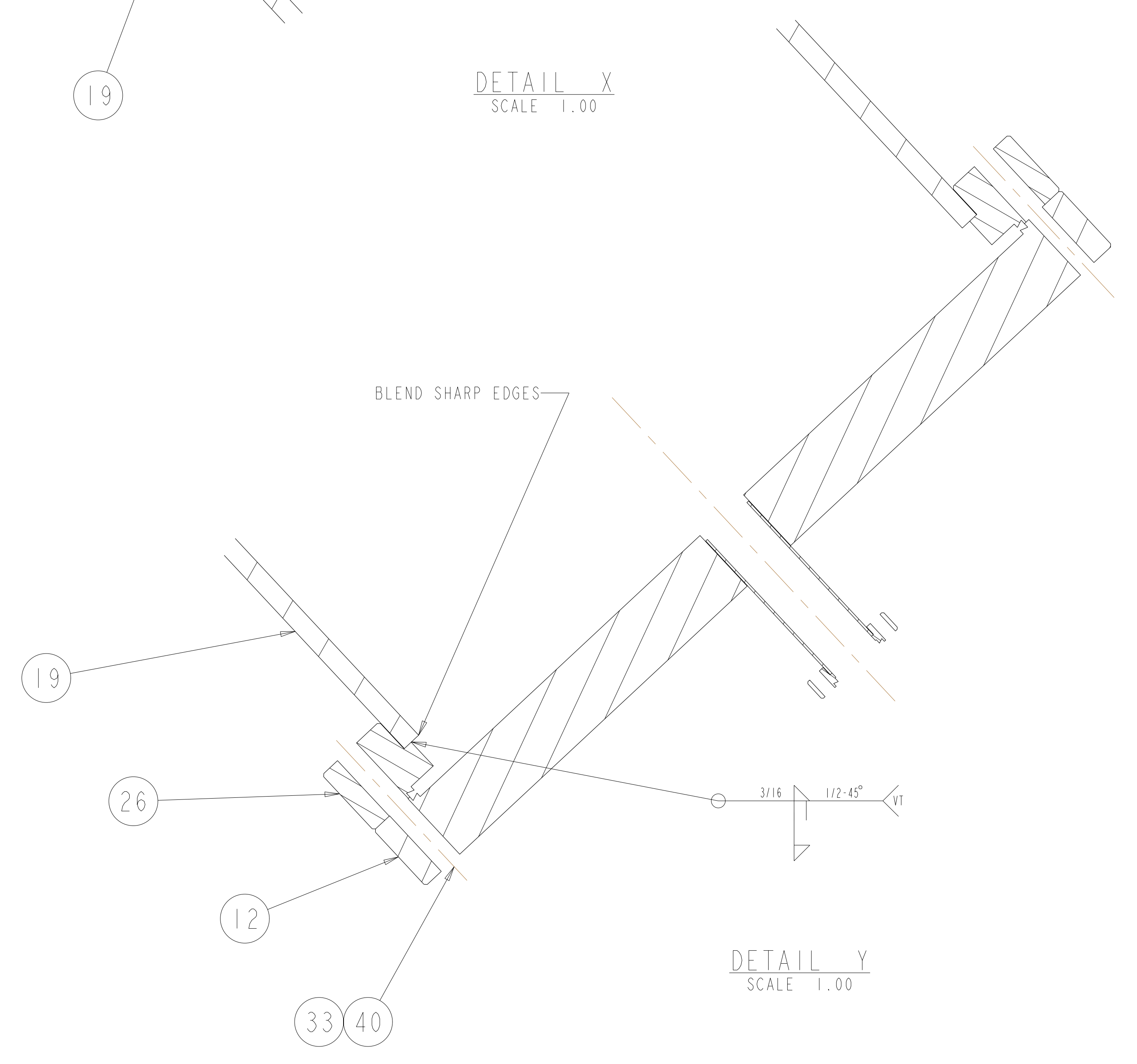

DETAIL Y  
SCALE 1.00

**RELEASED FOR  
FABRICATION / INSTALLATION**  
 PPPL Drafting:

UT-BATTELLE							Oak Ridge National Laboratory managed for the DEPARTMENT OF ENERGY under U.S. GOVERNMENT contract DE-AC05-00OR22725 UT-BATTELLE, LLC, Oak Ridge, Tennessee		
NATIONAL COMPACT STELLARATOR EXPERIMENT							PROJECT NAME		
VACUUM VESSEL							PERIOD INSPECTION AND LEAK CHECK		
ASSEMBLY							CLASS		
VERSION NO.	PLANT	BLDG	FL	SHT OF	TYPE	CLASS	REV	U	
5	X-10	5700	3	7 19	A	U	2		
RELEASE LEVEL	SE120-004						REV		
Fabrication									

H  
G  
F  
E  
D  
C  
B  
A

FOR PARTS LIST AND NOTES SEE SHEET 1.

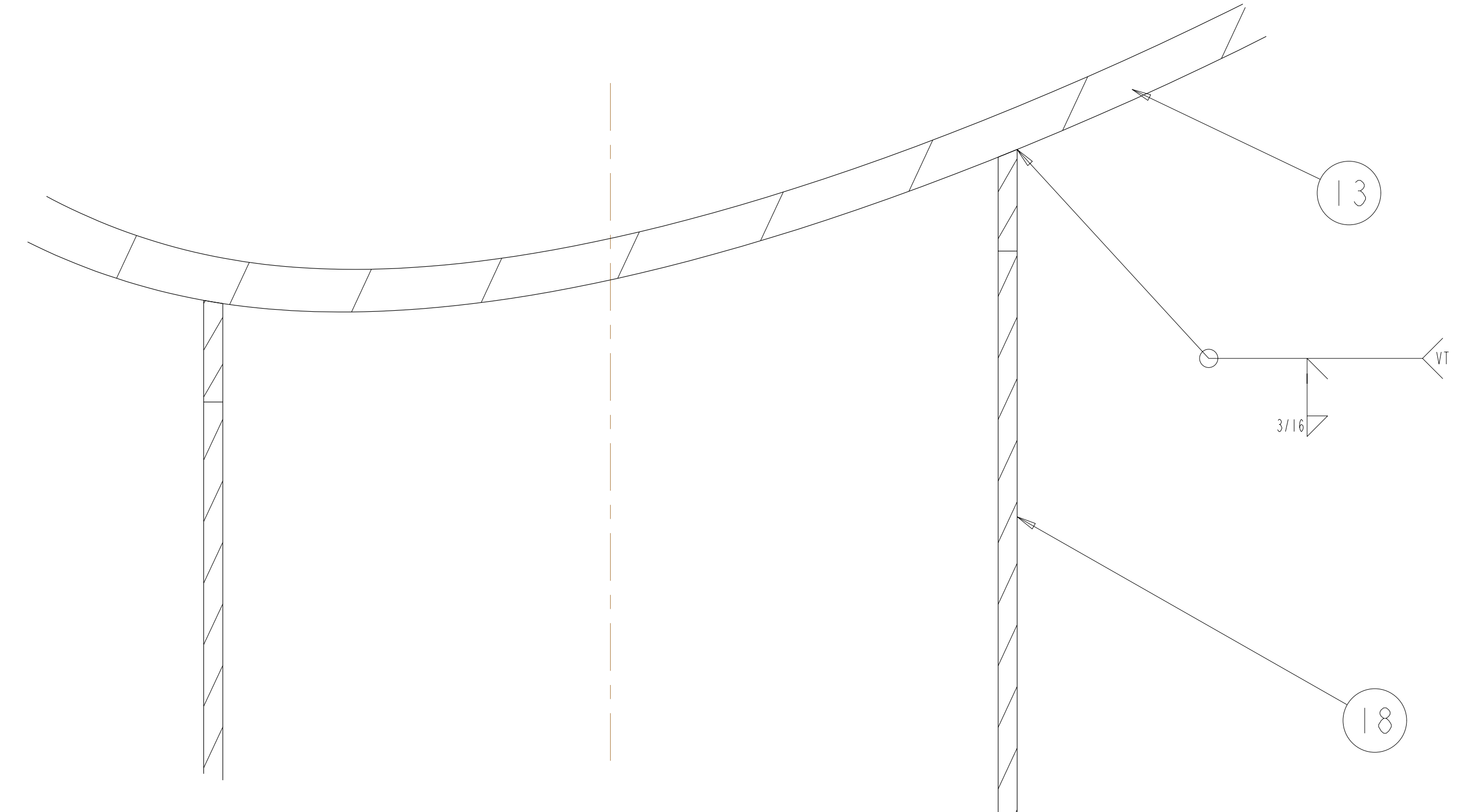
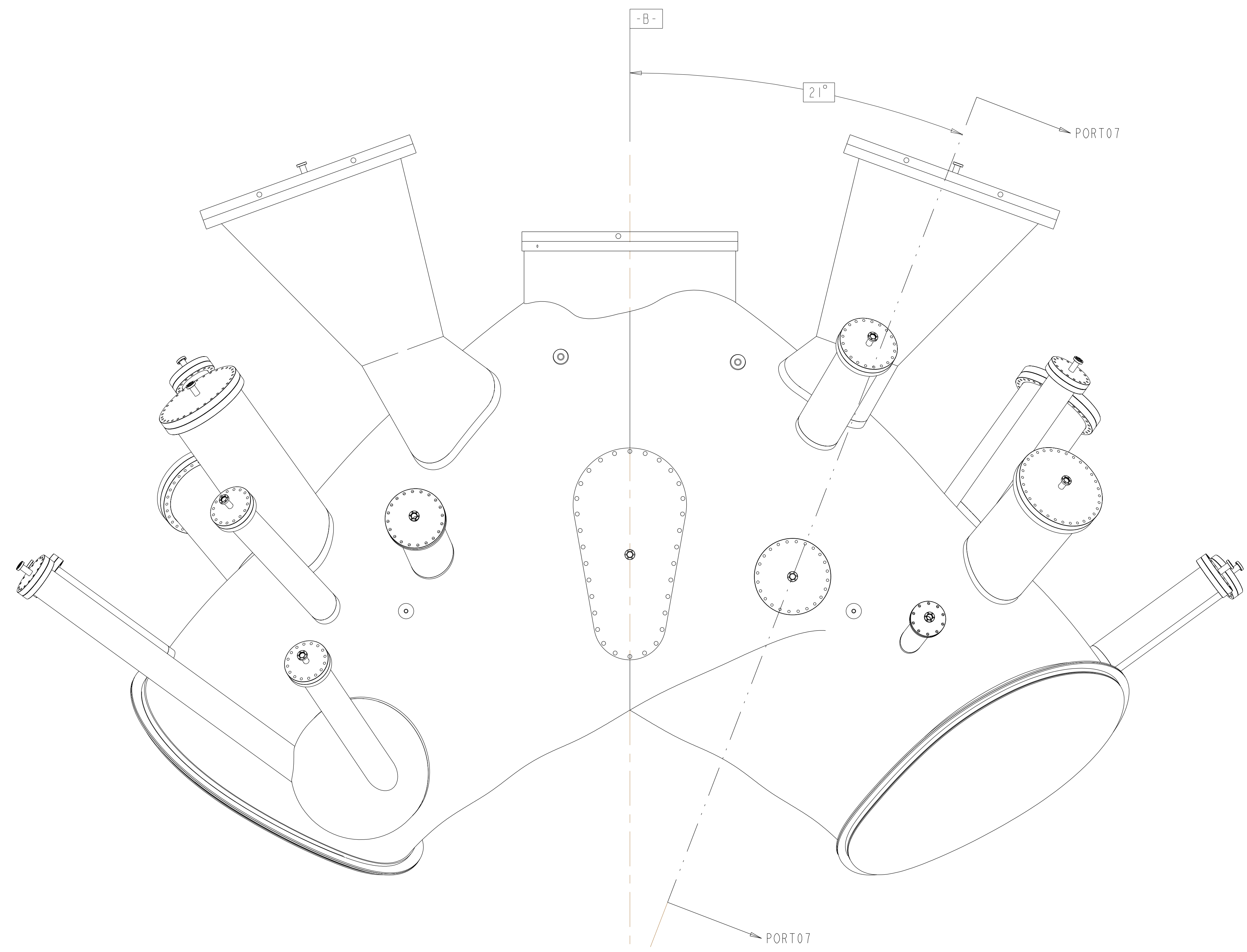

DETAIL X  
SCALE 1.00

BOTTOM VIEW

**ECN-5082.** Requirement originally included grooves to facilitate leak checking by vendor. However, vendor elected another means of leak checking and therefore the grooves are no longer required. Specifically, this ECN eliminated the leak checking groove on SE121-014 (Rev 1-c) and SE1221-091 (Rev 0-a). Additionally, this ECN added a missing weld symbol to SE121-004 (Sheets 4 through 19) for joining the port extensions to the vessel (Rev 2-d).  
 (See ECN-5082 for details)

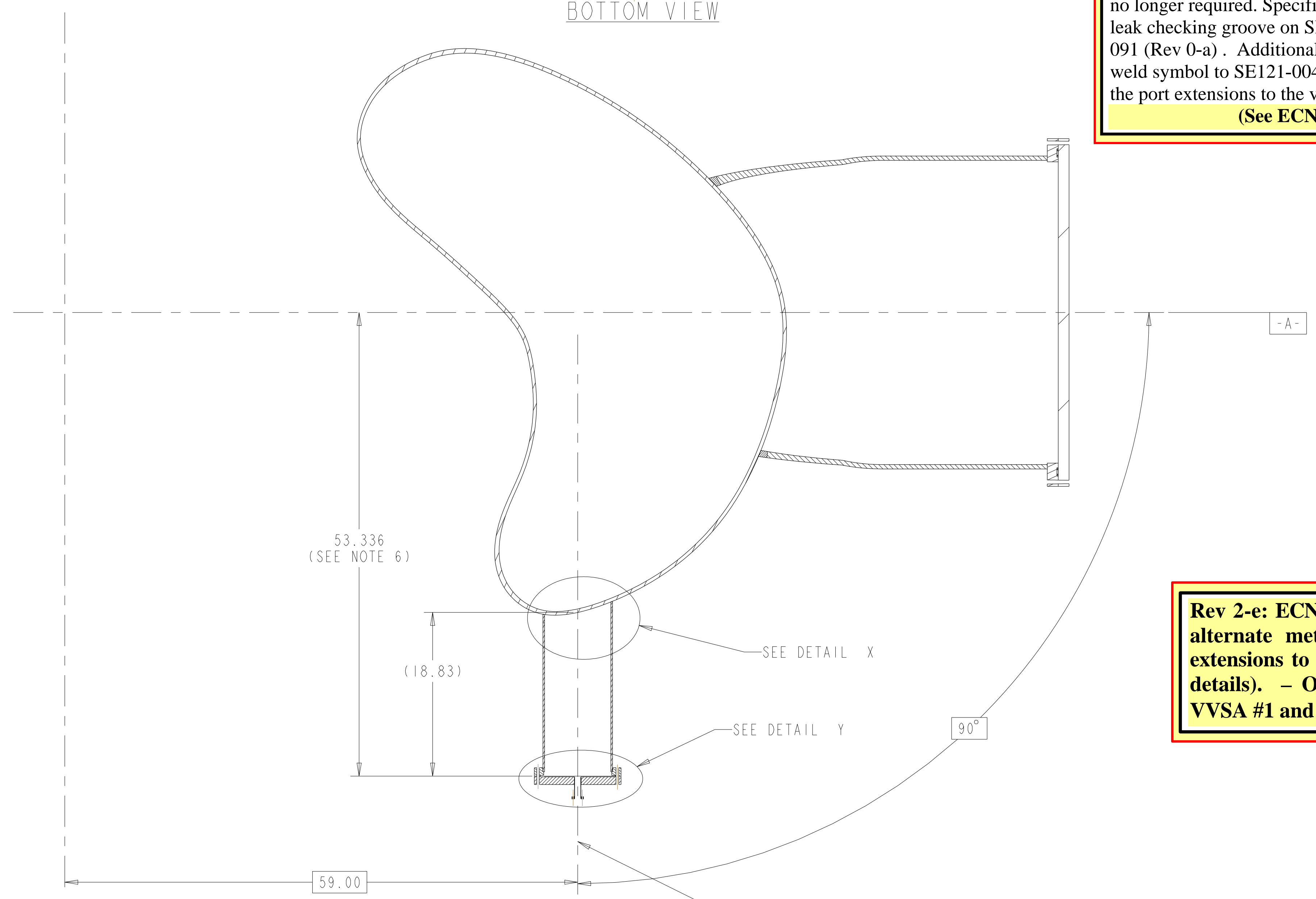

TYPICAL PORT 7A AND 7B SECTION PORT07-PORT07  
 $\varnothing .250$  A B C

**Rev 2-c: ECN-5021 (RFD-12-017) approved alternate methods for welding the port extensions to the VVSA (See ECN-5021 for details). - Only applicable to VVSA #3 - VVSA #1 and #2 covered by NCR 19464.**

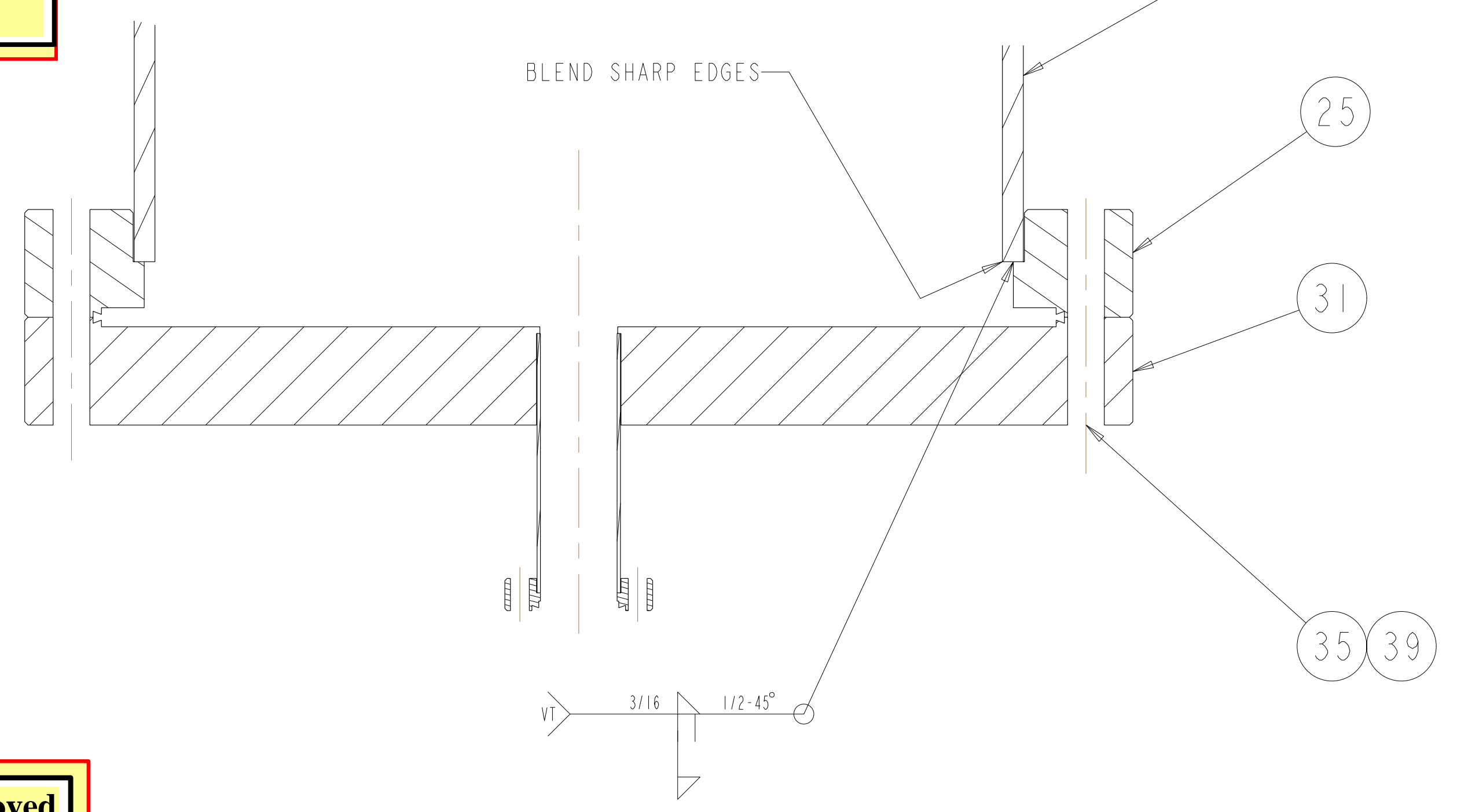

DETAIL Y  
SCALE 1.00

**RELEASED FOR FABRICATION / INSTALLATION**  
 PPPL Drafting:

UT-BATTELLE		Oak Ridge National Laboratory managed for the DEPARTMENT OF ENERGY under U.S. GOVERNMENT contract DE-AC05-00OR22725 UT-BATTELLE, LLC, Oak Ridge, Tennessee	
PROJECT NAME			
NATIONAL COMPACT STELLARATOR EXPERIMENT			
VACUUM VESSEL PERIOD INSPECTION AND LEAK CHECK ASSEMBLY			
VERSION NO.	PLANT	BLDG	FL
5	X-10	5700	3
RELEASE LEVEL			
Fabrication			
SHT OF	TYPE	CLASS	
8 19	A	U	
SE120-004			REV 2

SE120-004



FOR PARTS LIST AND NOTES SEE SHEET 1.

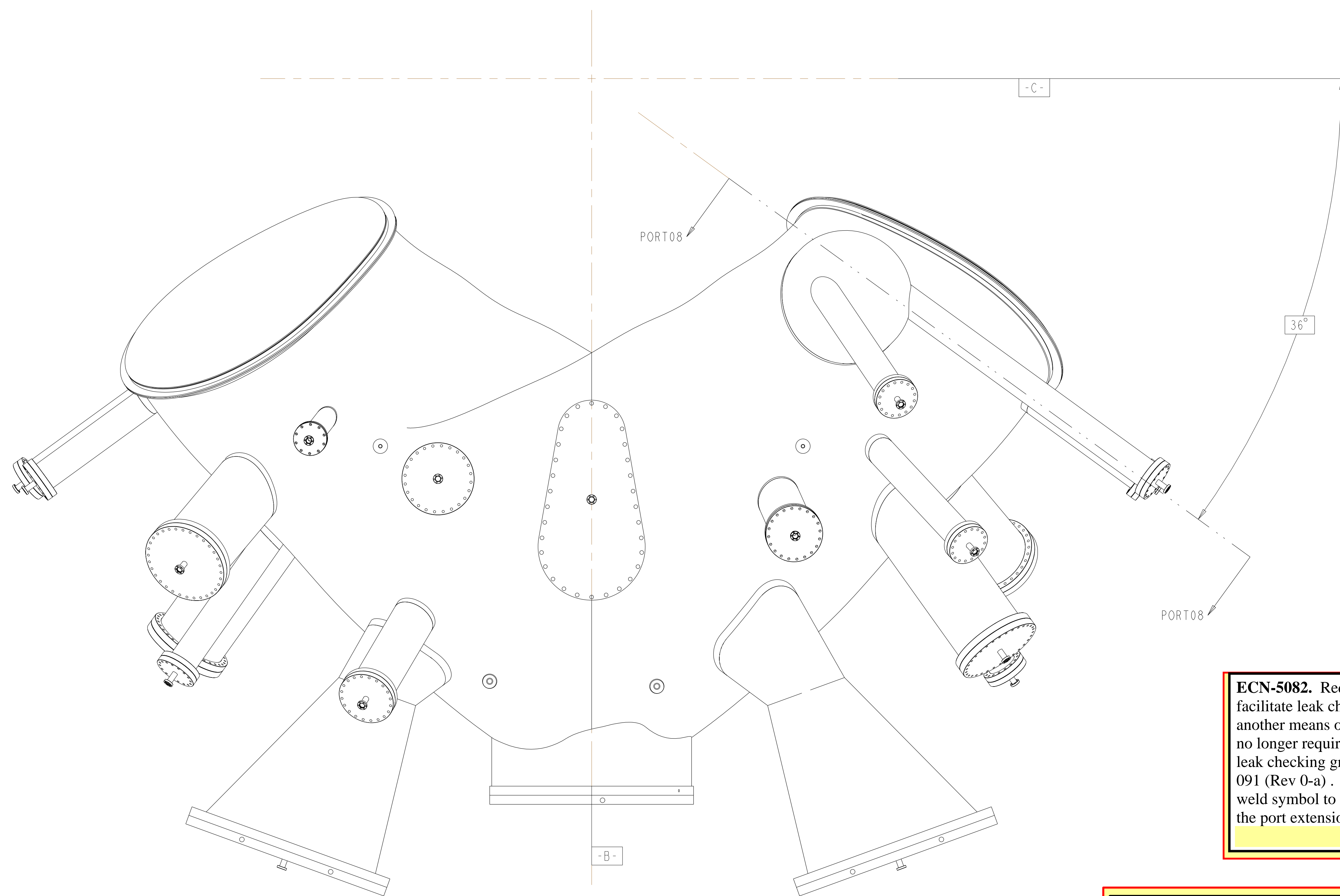

TOP VIEW

**ECN-5082.** Requirement originally included grooves to facilitate leak checking by vendor. However, vendor elected another means of leak checking and therefore the grooves are no longer required. Specifically, this ECN eliminated the leak checking groove on SE121-014 (Rev 1-c) and SE1221-091 (Rev 0-a). Additionally, this ECN added a missing weld symbol to SE121-004 (Sheets 4 through 19) for joining the port extensions to the vessel (Rev 2-d).  
**(See ECN-5082 for details)**

**Rev 2-e: ECN-5021 (RFD-12-017) approved alternate methods for welding the port extensions to the VVSA (See ECN-5021 for details). - Only applicable to VVSA #3 - VVSA #1 and #2 covered by NCR 19464.**

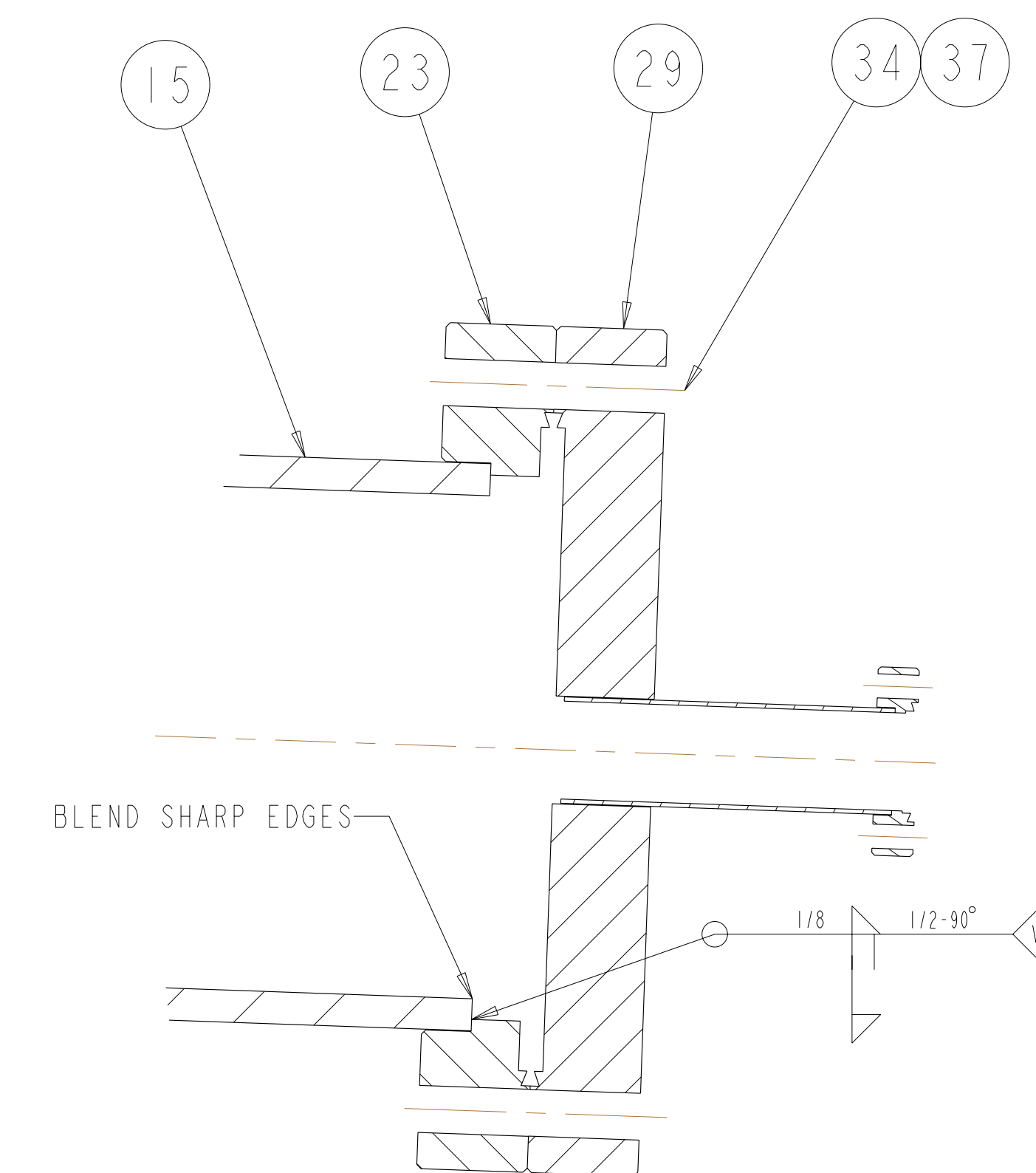

DETAIL Y  
SCALE 1.00

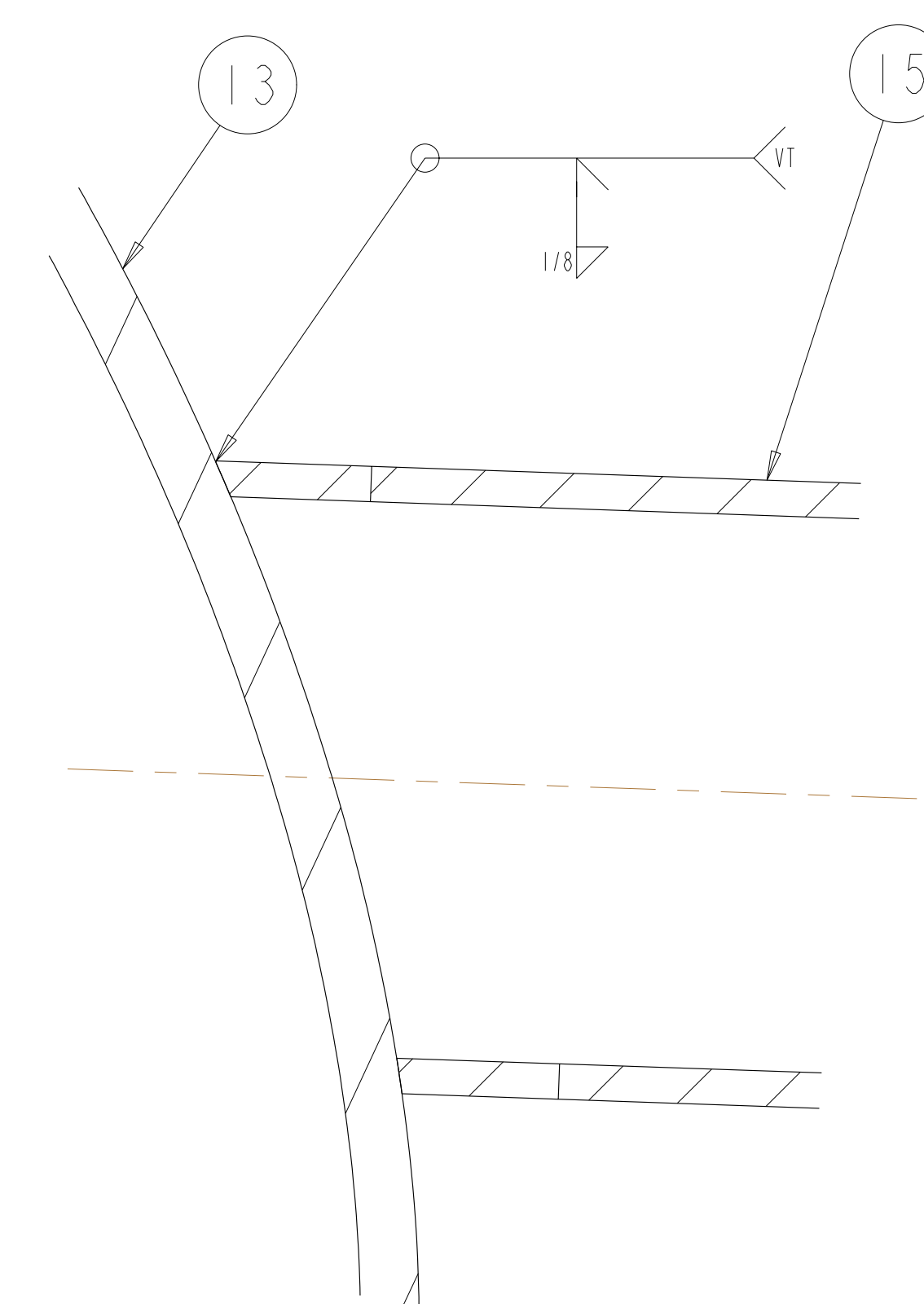

DETAIL X  
SCALE 1.00

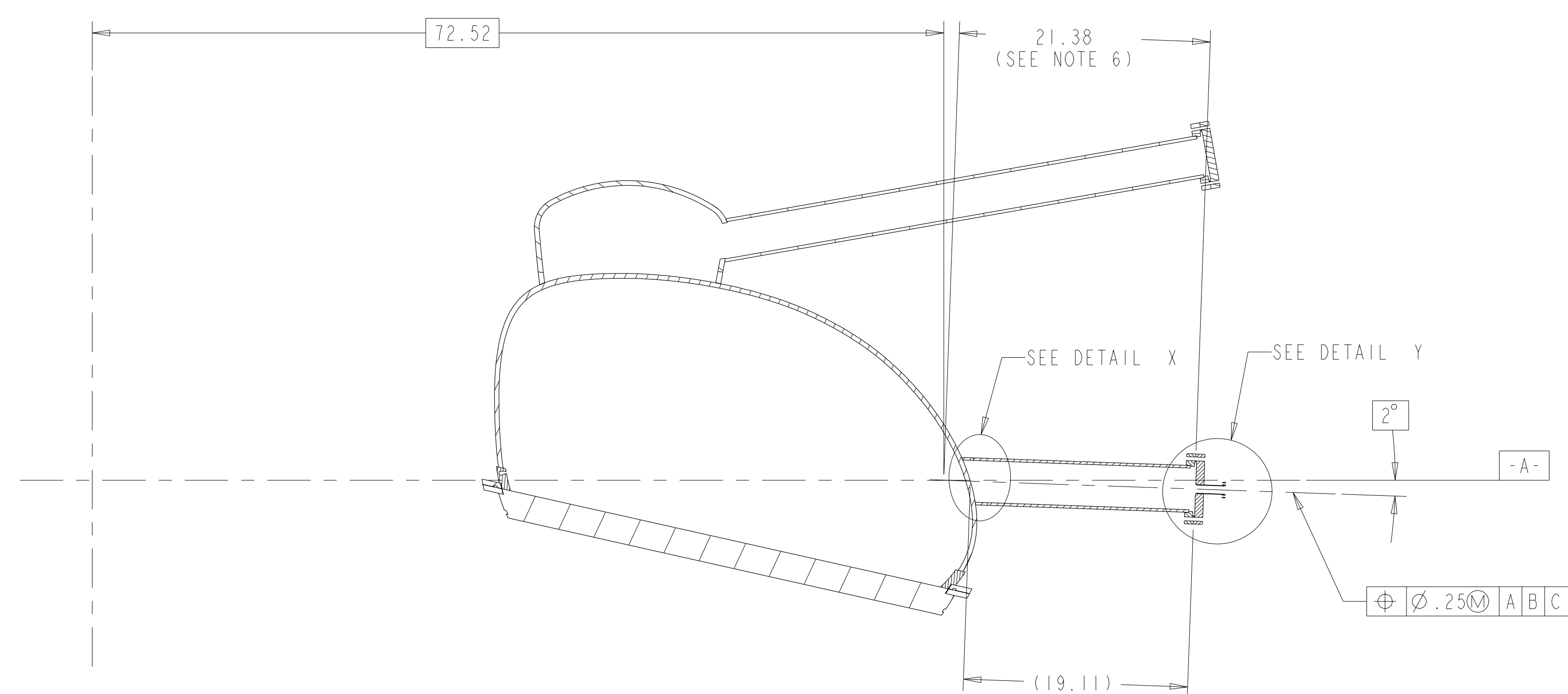

TYPICAL PORT 8A AND 8B  
SECTION PORT08-PORT08

**RELEASED FOR  
FABRICATION / INSTALLATION**  
 PPPL Drafting:

UT-BATTELLE		Oak Ridge National Laboratory managed for the DEPARTMENT OF ENERGY under U.S. GOVERNMENT contract DE-AC05-00OR22725 UT-BATTELLE, LLC., Oak Ridge, Tennessee					
PROJECT NAME		NATIONAL COMPACT STELLERATOR EXPERIMENT					
SUBJECT		VACUUM VESSEL PERIOD INSPECTION AND LEAK CHECK ASSEMBLY					
VERSION NO.	PLANT	BLDG	FL	SHT OF	TYPE	CLASS	
5	X-10	5700	3	9	19	A	U
RELEASE LEVEL	SE120-004						REV
Fabrication							2

SE120-004

A

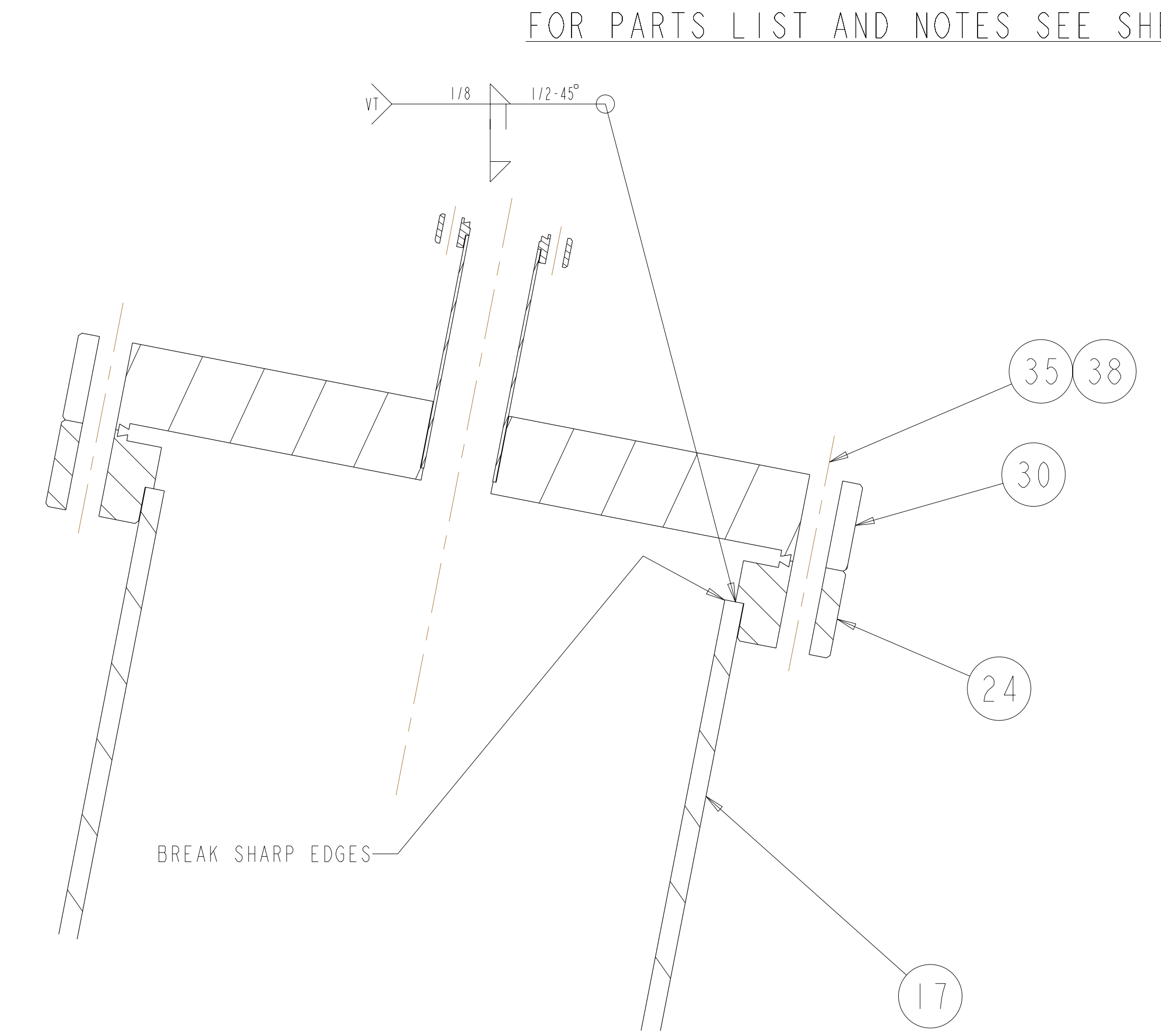
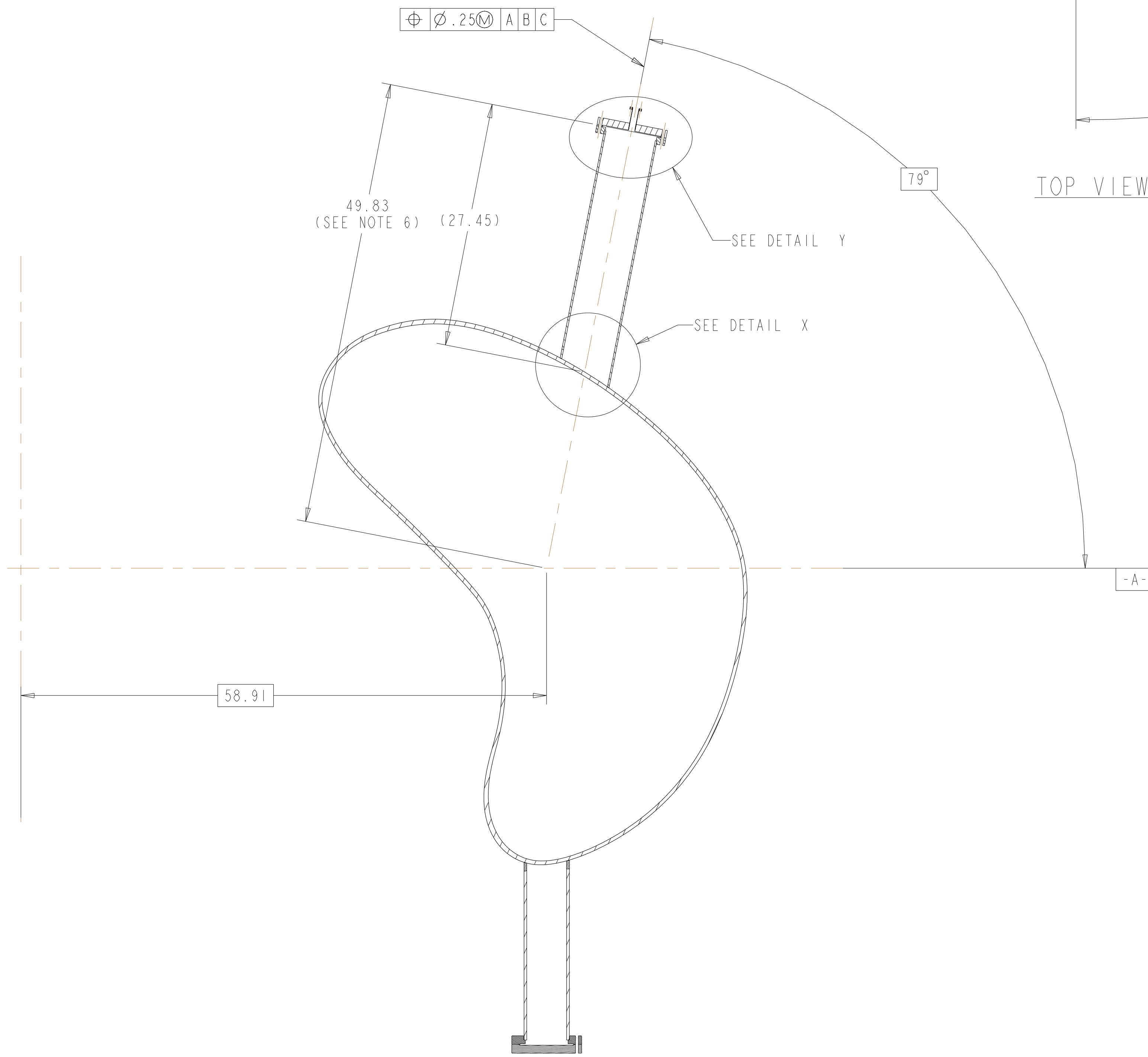
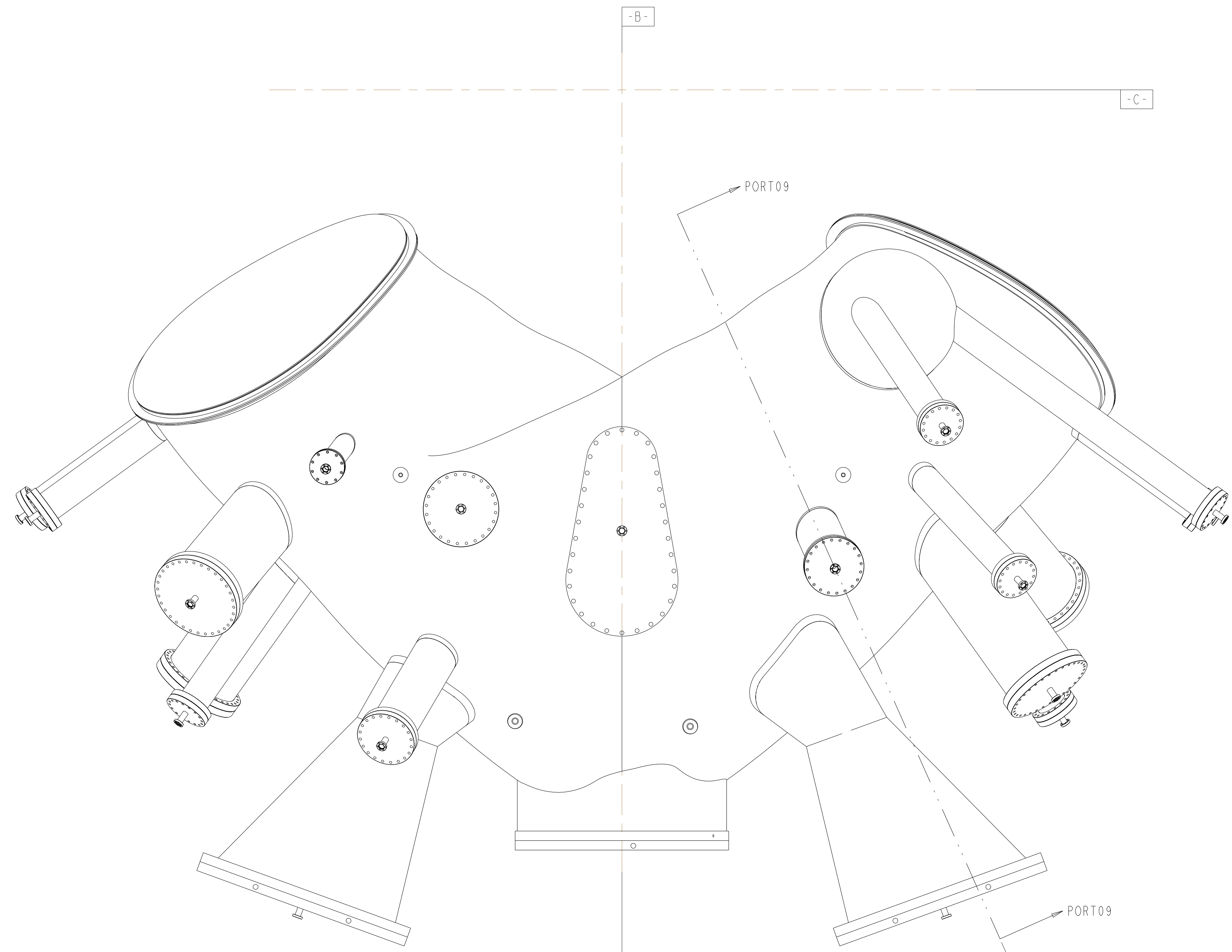

DETAIL Y  
 SCALE 1.00

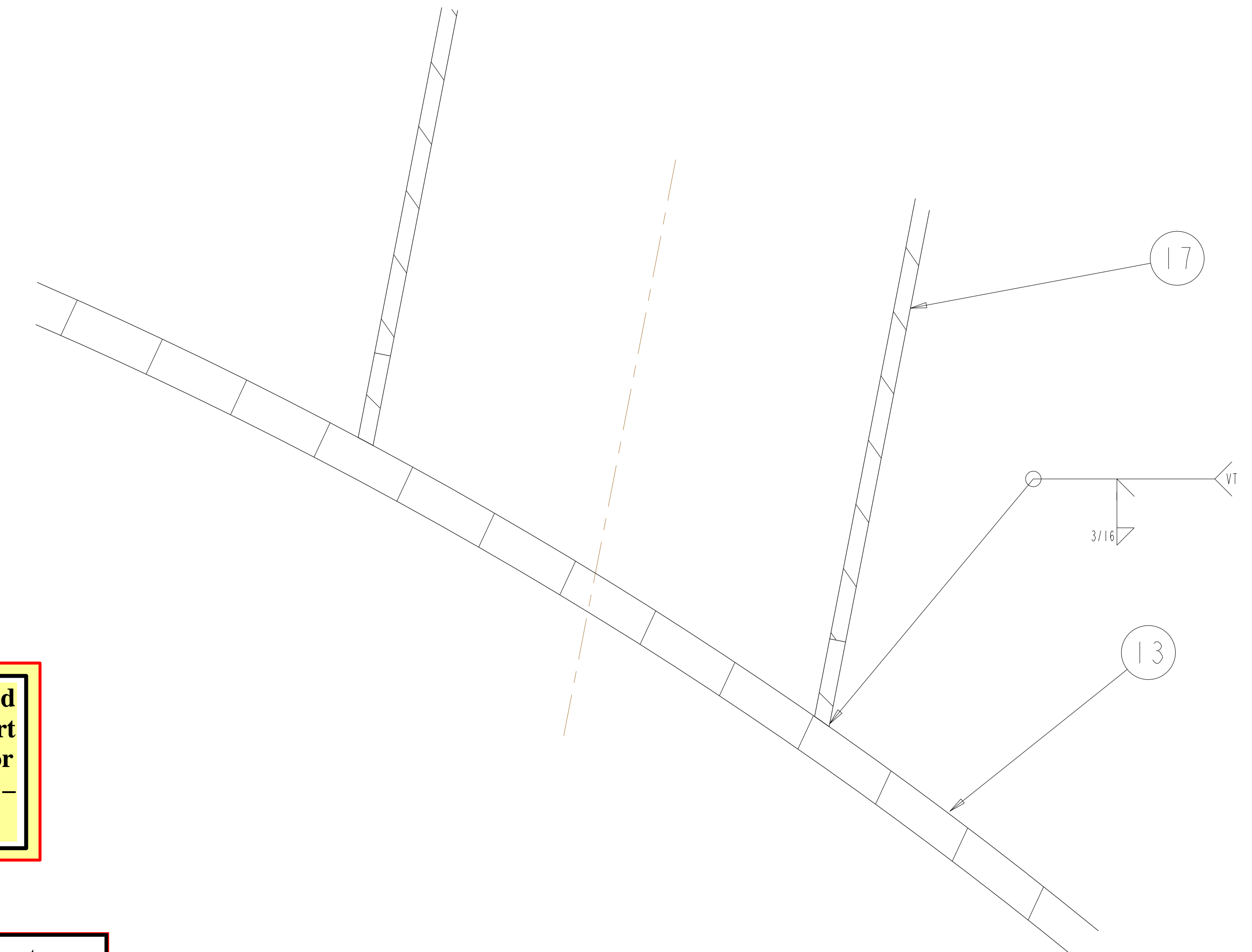

DETAIL X  
 SCALE 1.00

**Rev 2-e: ECN-5021 (RFD-12-017) approved alternate methods for welding the port extensions to the VVSA (See ECN-5021 for details). - Only applicable to VVSA #3 - VVSA #1 and #2 covered by NCR 19464.**

**ECN-5082.** Requirement originally included grooves to facilitate leak checking by vendor. However, vendor elected another means of leak checking and therefore the grooves are no longer required. Specifically, this ECN eliminated the leak checking groove on SE121-014 (Rev 1-c) and SE1221-091 (Rev 0-a). Additionally, this ECN added a missing weld symbol to SE121-004 (Sheets 4 through 19) for joining the port extensions to the vessel (Rev 2-d).  
 (See ECN-5082 for details)

**RELEASED FOR FABRICATION / INSTALLATION**  
 PPPL Drafting:

TYPICAL PORT 9A AND 9B SECTION PORT09-PORT09

UT-BATTELLE		Oak Ridge National Laboratory managed for the DEPARTMENT OF ENERGY under U.S. GOVERNMENT contract DE-AC05-00OR22725 UT-BATTELLE, LLC, Oak Ridge, Tennessee					
PROJECT NAME							
NATIONAL COMPACT STELLARATOR EXPERIMENT							
VACUUM VESSEL							
PERIOD INSPECTION AND LEAK CHECK ASSEMBLY							
VERSION NO.	PLANT	BLDG	FL	SHT OF	TYPE	CLASS	
5	X-10	5700	3	10	19	A	U
RELEASE LEVEL		SE120-004					
Fabrication							
							REV 2

H  
G  
F  
E  
D  
C  
B  
A

SE120-004

FOR PARTS LIST AND NOTES SEE SHEET 1.

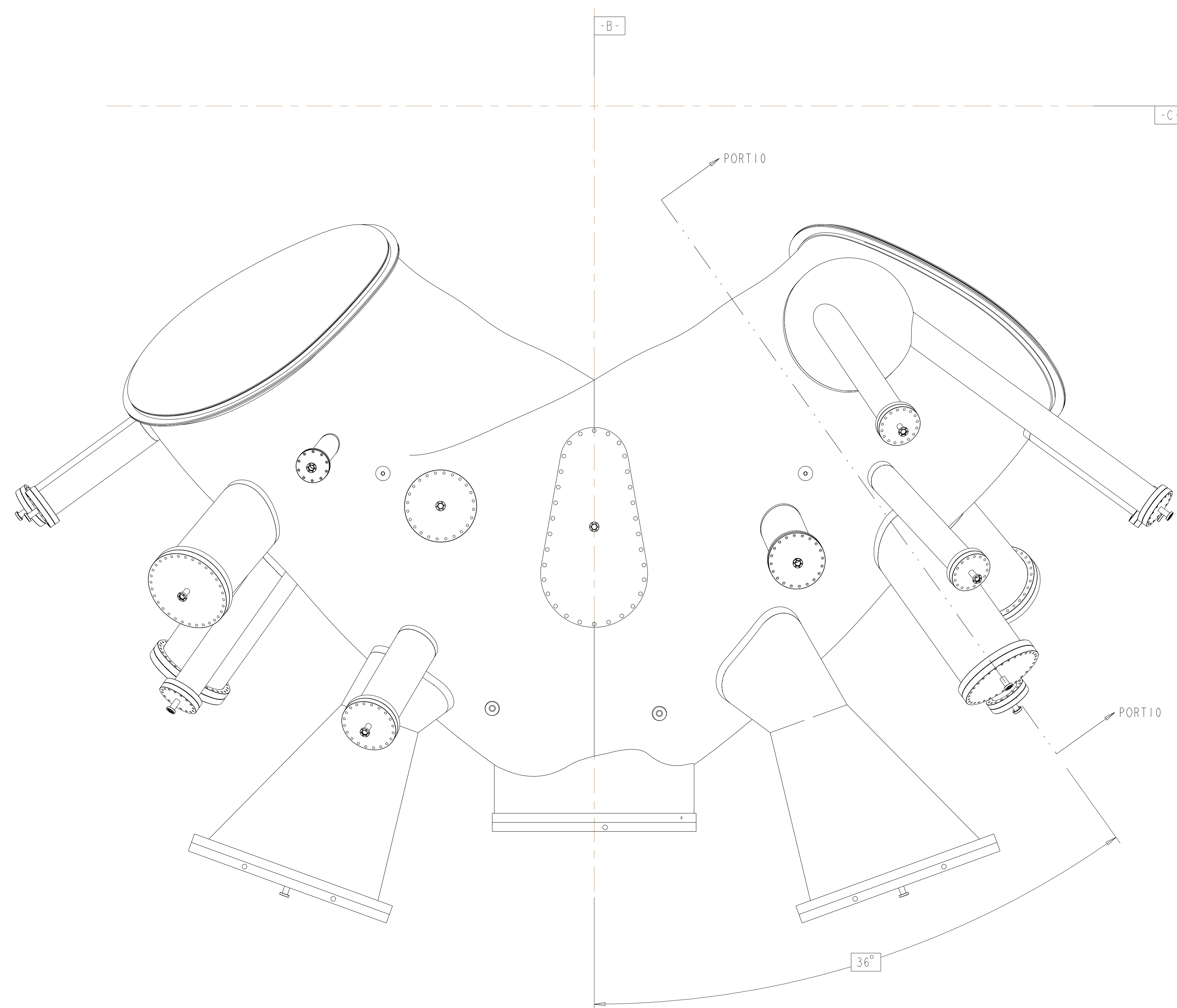

TOP VIEW

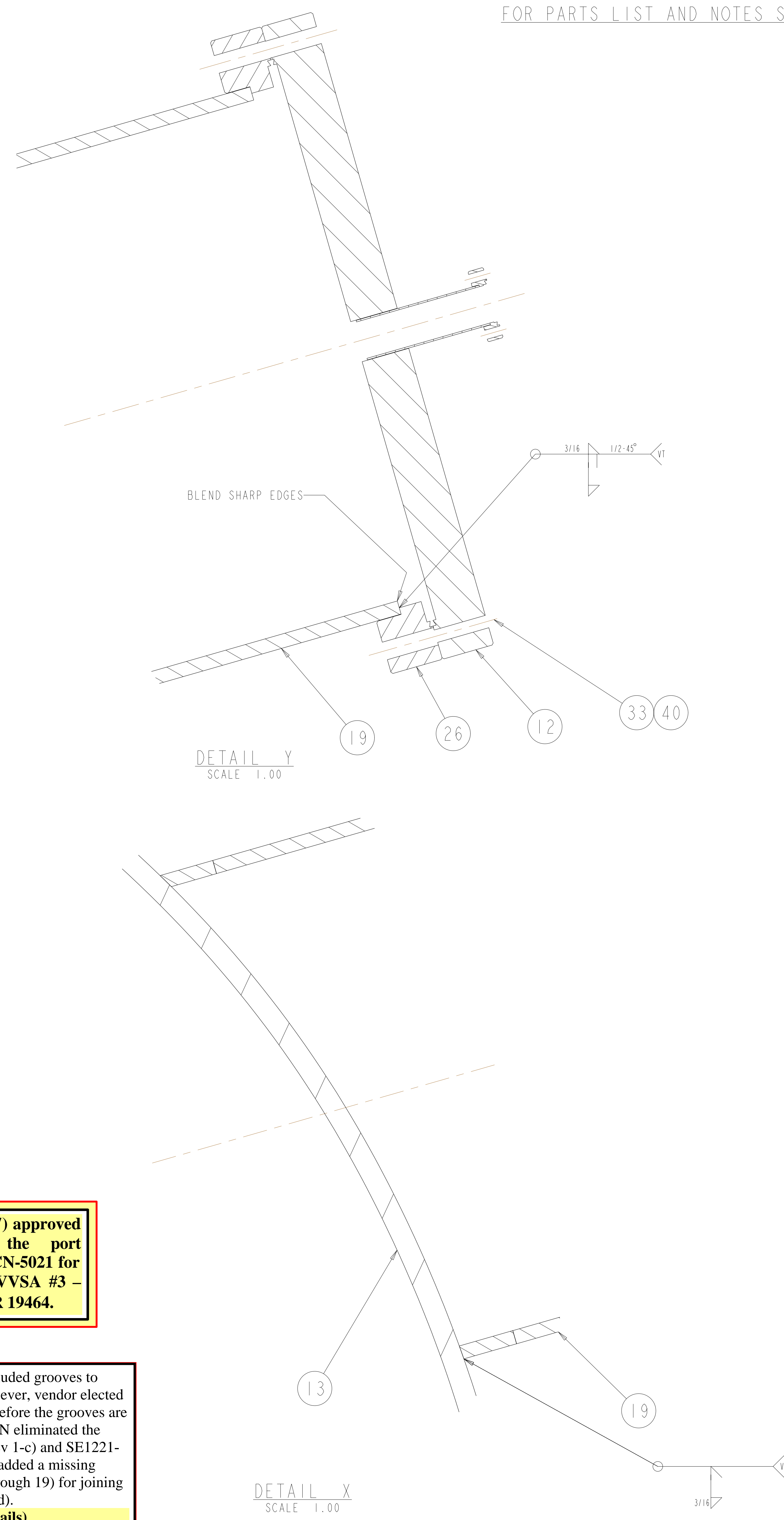

DETAIL Y  
SCALE 1.00

DETAIL X  
SCALE 1.00

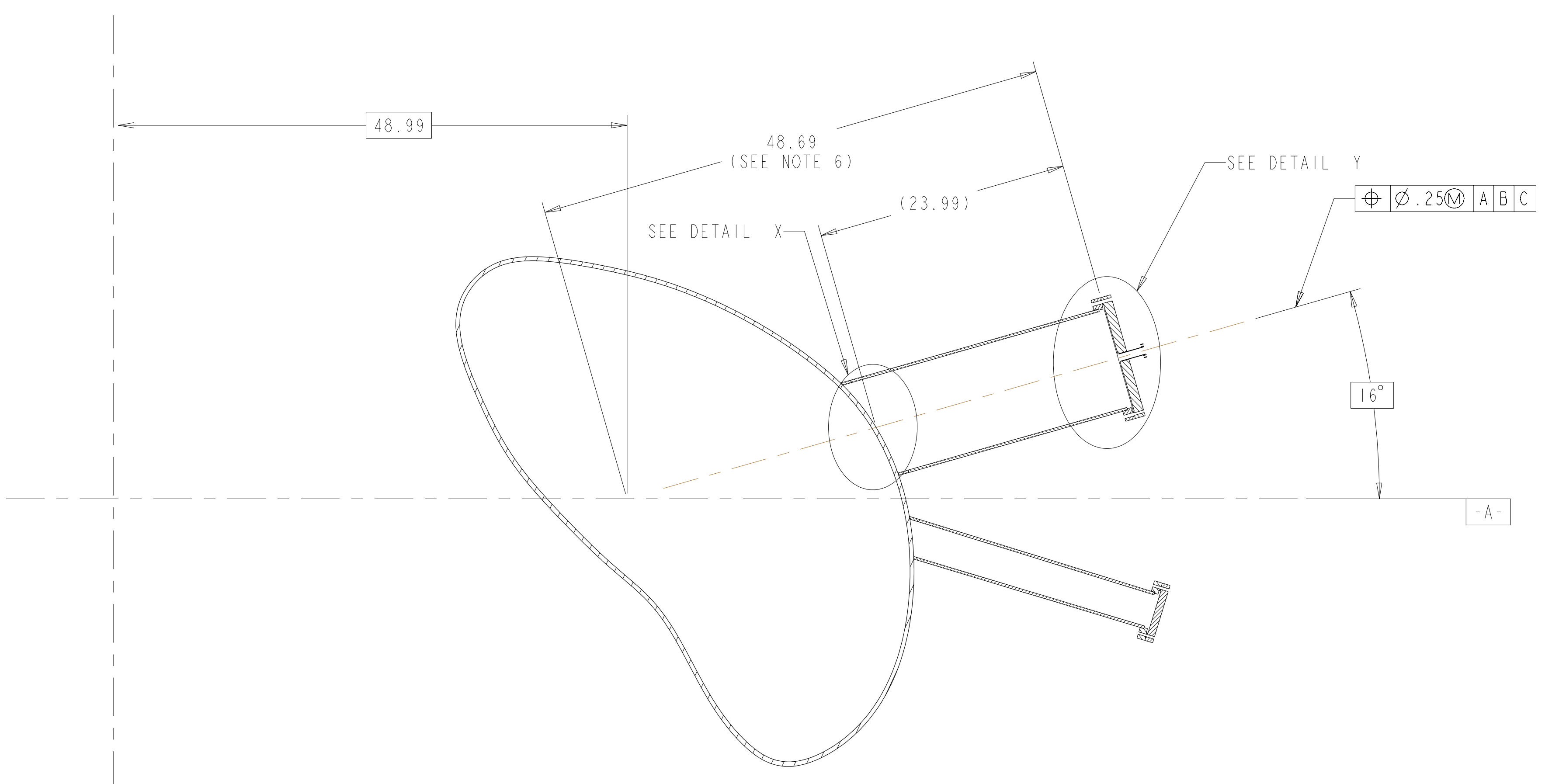

TYPICAL PORT 10A AND 10B  
SECTION PORT10-PORT10

**Rev 2-e: ECN-5021 (RFD-12-017) approved alternate methods for welding the port extensions to the VVSA (See ECN-5021 for details). – Only applicable to VVSA #3 – VVSA #1 and #2 covered by NCR 19464.**

**ECN-5082.** Requirement originally included grooves to facilitate leak checking by vendor. However, vendor elected another means of leak checking and therefore the grooves are no longer required. Specifically, this ECN eliminated the leak checking groove on SE121-014 (Rev 1-c) and SE1221-091 (Rev 0-a). Additionally, this ECN added a missing weld symbol to SE121-004 (Sheets 4 through 19) for joining the port extensions to the vessel (Rev 2-d).  
**(See ECN-5082 for details)**

**RELEASED FOR  
FABRICATION / INSTALLATION**  
PPPL Drafting:

UT-BATTELLE		Oak Ridge National Laboratory managed for the DEPARTMENT OF ENERGY under U.S. GOVERNMENT contract DE-AC05-00OR22725 UT-BATTELLE, LLC, Oak Ridge, Tennessee					
NATIONAL COMPACT STELLARATOR EXPERIMENT		PROJECT NAME					
VACUUM VESSEL		PERIOD INSPECTION AND LEAK CHECK					
ASSEMBLY		CLASS					
VERSION NO.	PLANT	BLDG	FL	SHT OF	TYPE	CLASS	
5	X-10	5700	3	11 19	A	U	
RELEASE LEVEL	SE120-004						REV
Fabrication							2

H  
G  
F  
E  
D  
C  
B  
A



FOR PARTS LIST AND NOTES SEE SHEET 1.

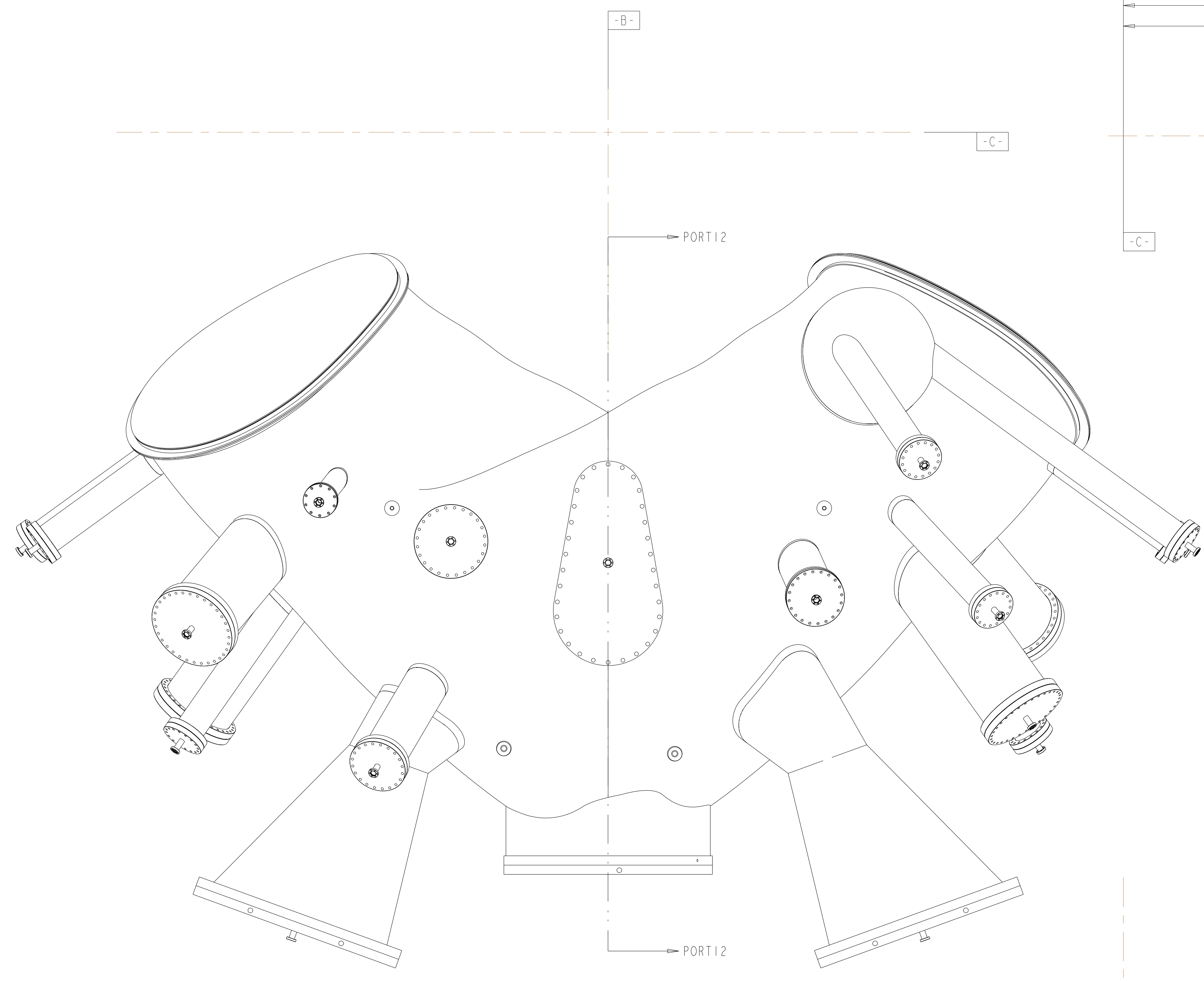

TOP VIEW

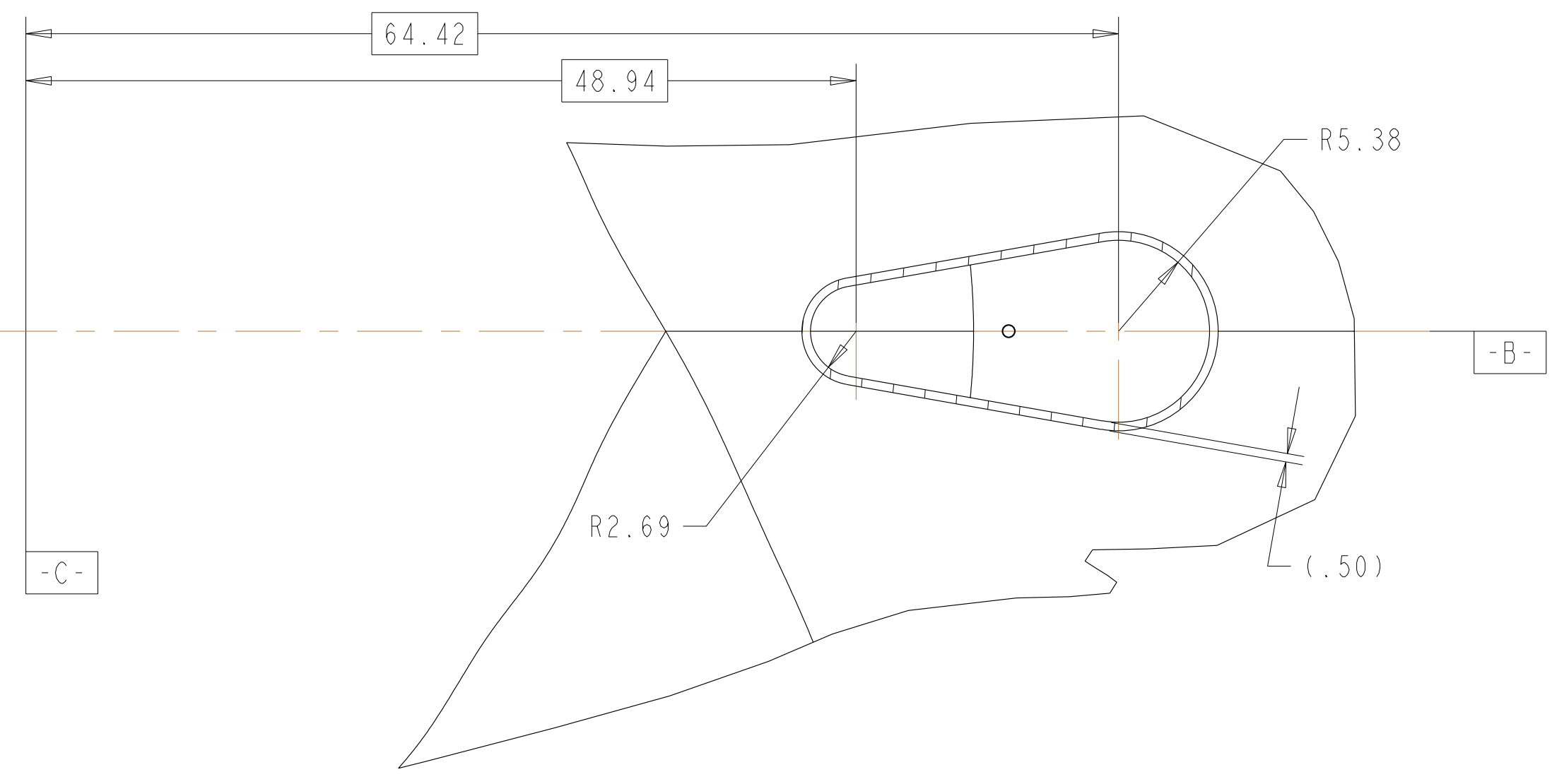

SECTION J-J  
TYP TOP AND BOTTOM

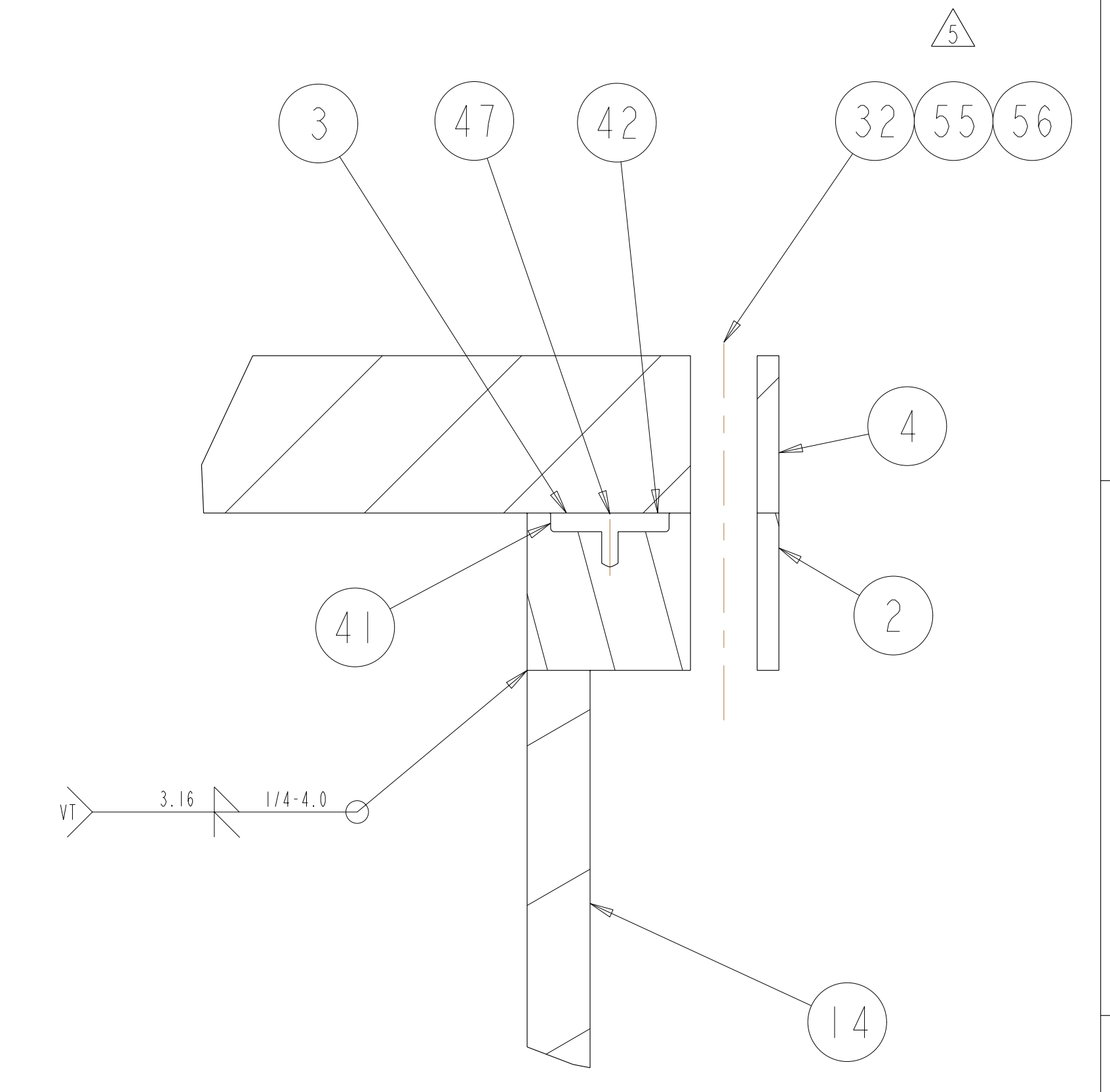

DETAIL Y  
SCALE 1.00

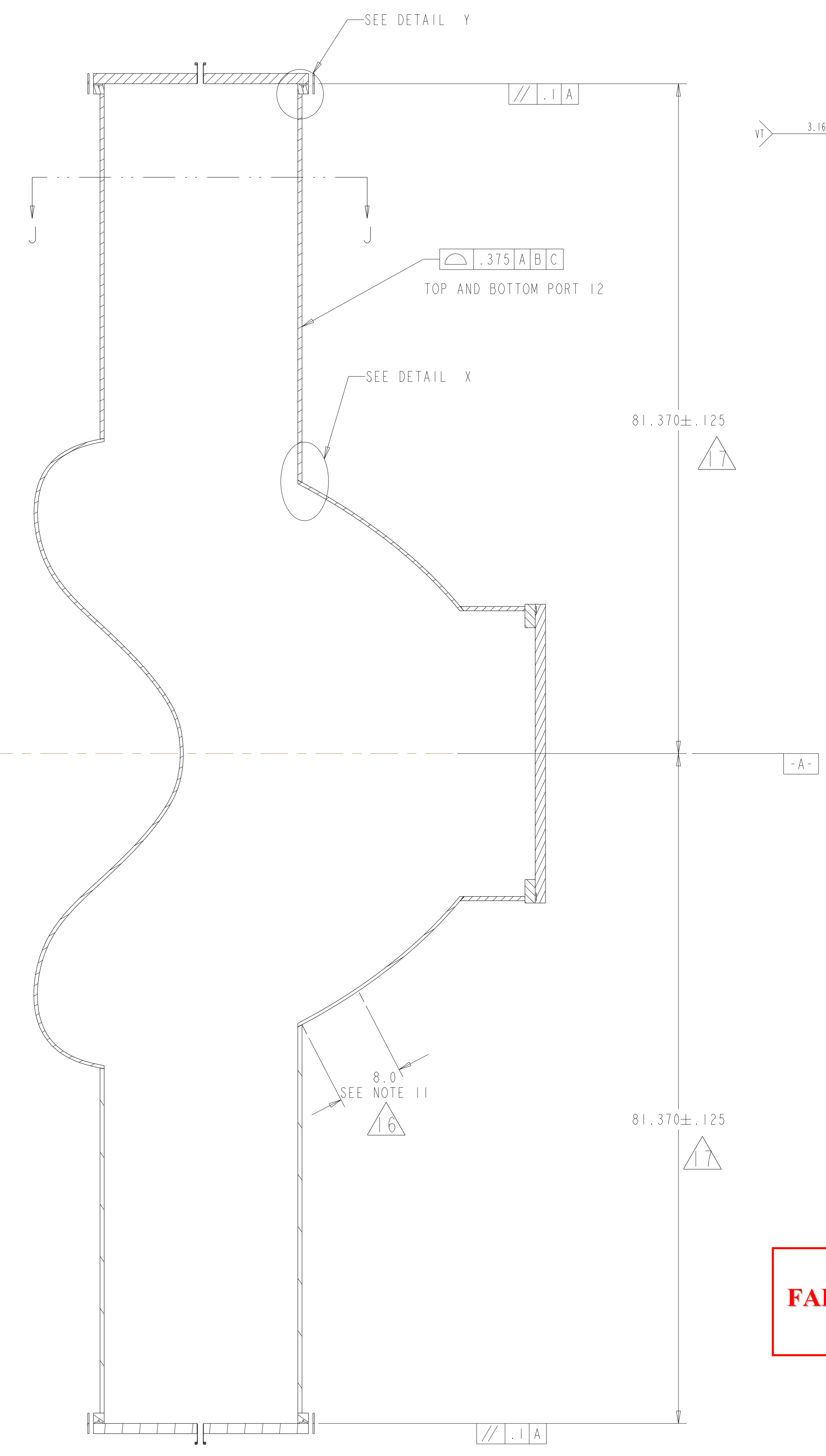

SECTION PORT12-PORT12

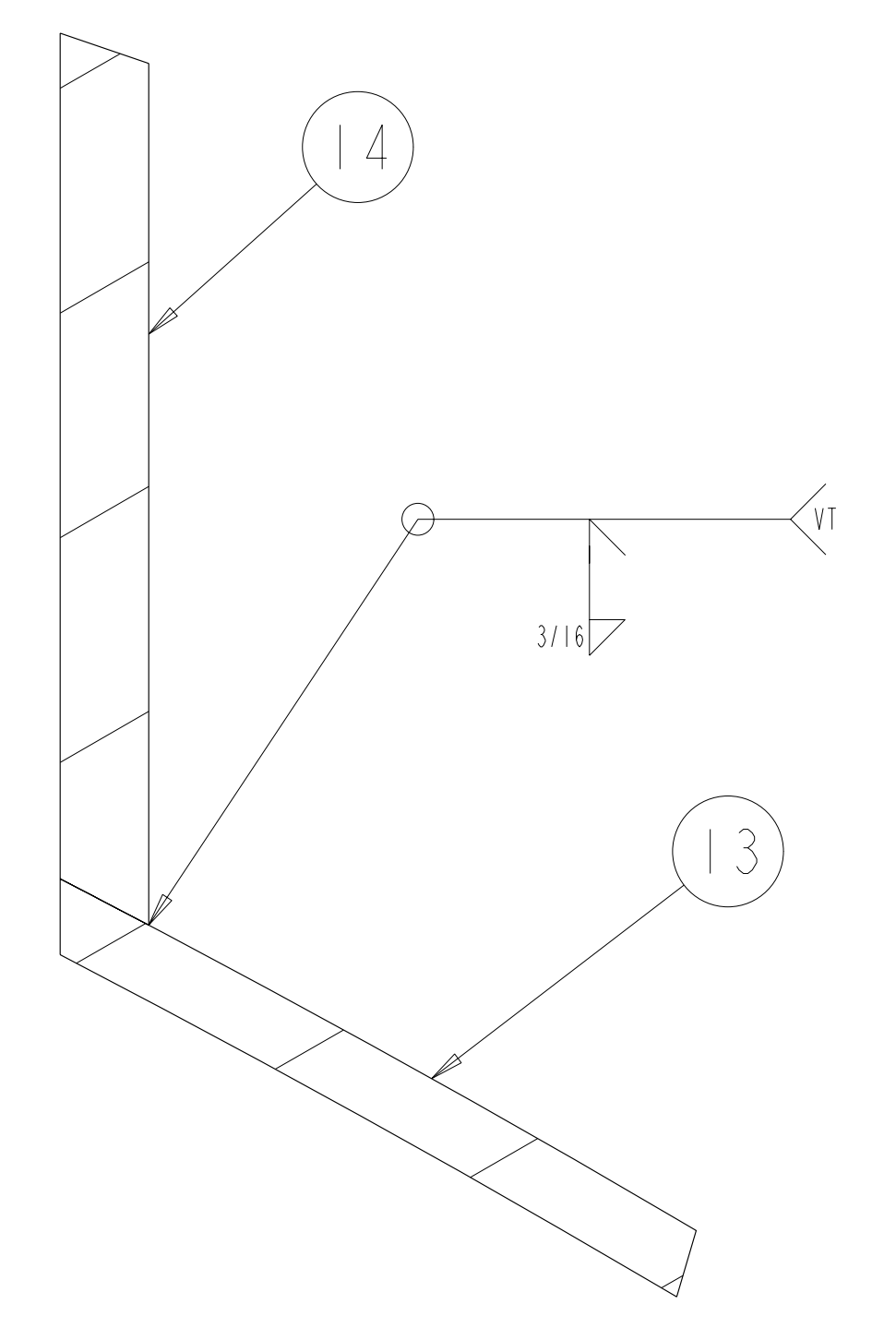

DETAIL X  
SCALE 1.00

**Rev 2-e: ECN-5021 (RFD-12-017) approved alternate methods for welding the port extensions to the VVSA (See ECN-5021 for details). - Only applicable to VVSA #3 - VVSA #1 and #2 covered by NCR 19464.**

**ECN-5082.** Requirement originally included grooves to facilitate leak checking by vendor. However, vendor elected another means of leak checking and therefore the grooves are no longer required. Specifically, this ECN eliminated the leak checking groove on SE121-014 (Rev 1-c) and SE1221-091 (Rev 0-a). Additionally, this ECN added a missing weld symbol to SE121-004 (Sheets 4 through 19) for joining the port extensions to the vessel (Rev 2-d).  
(See ECN-5082 for details)

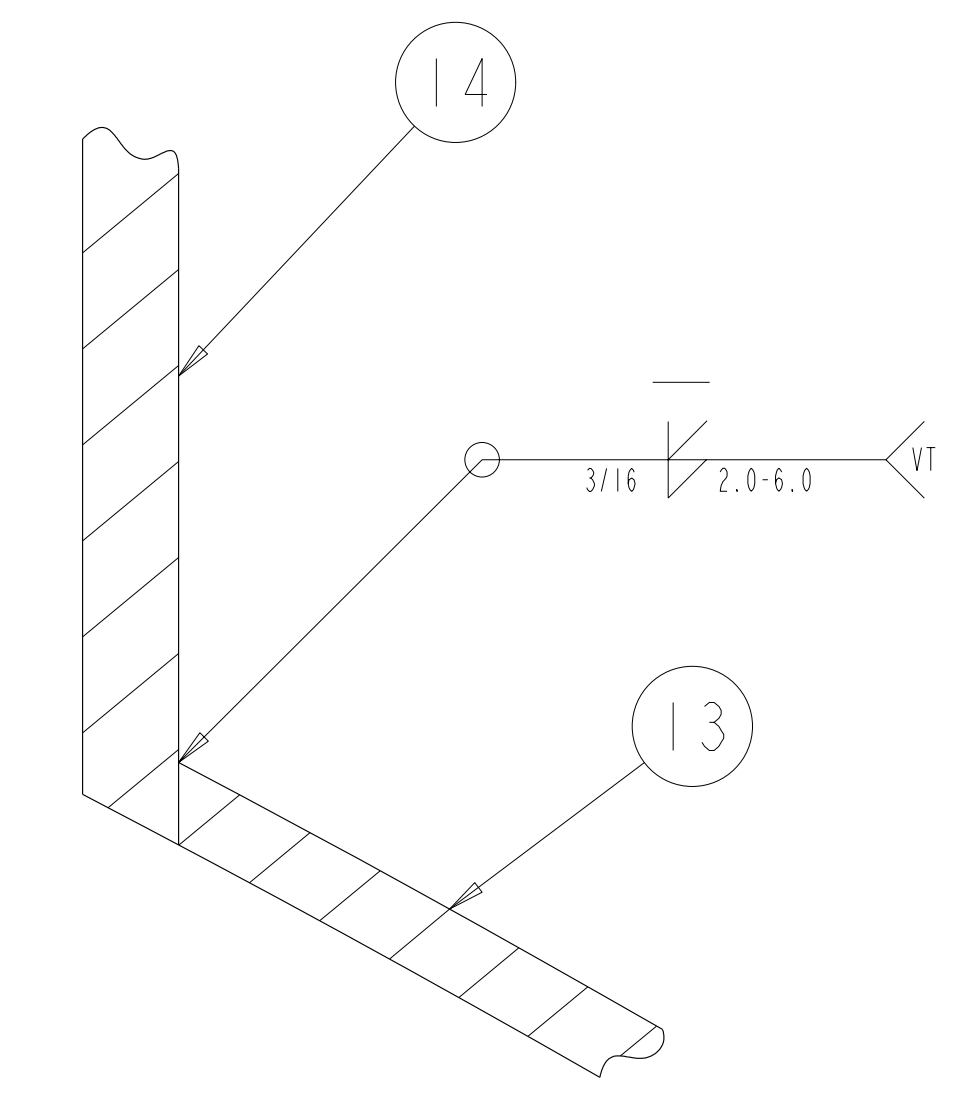

OPTIONAL WELD DETAIL

**RELEASED FOR FABRICATION / INSTALLATION**  
 PPPL Drafting:

UT-BATTELLE		Oak Ridge National Laboratory managed for the DEPARTMENT OF ENERGY under U.S. GOVERNMENT contract DE-AC05-00OR22725 UT-BATTELLE, LLC, Oak Ridge, Tennessee					
NATIONAL COMPACT STELLARATOR EXPERIMENT							
VACUUM VESSEL							
PERIOD INSPECTION AND LEAK CHECK ASSEMBLY							
VERSION NO.	PLANT	BLDG	FL	SHT OF	TYPE	CLASS	
5	X-10	5700	3	13 19	A	U	
RELEASE LEVEL	SE120-004						REV
Fabrication							2

H  
G  
F  
E  
D  
C  
B  
A

FOR PARTS LIST AND NOTES SEE SHEET 1.

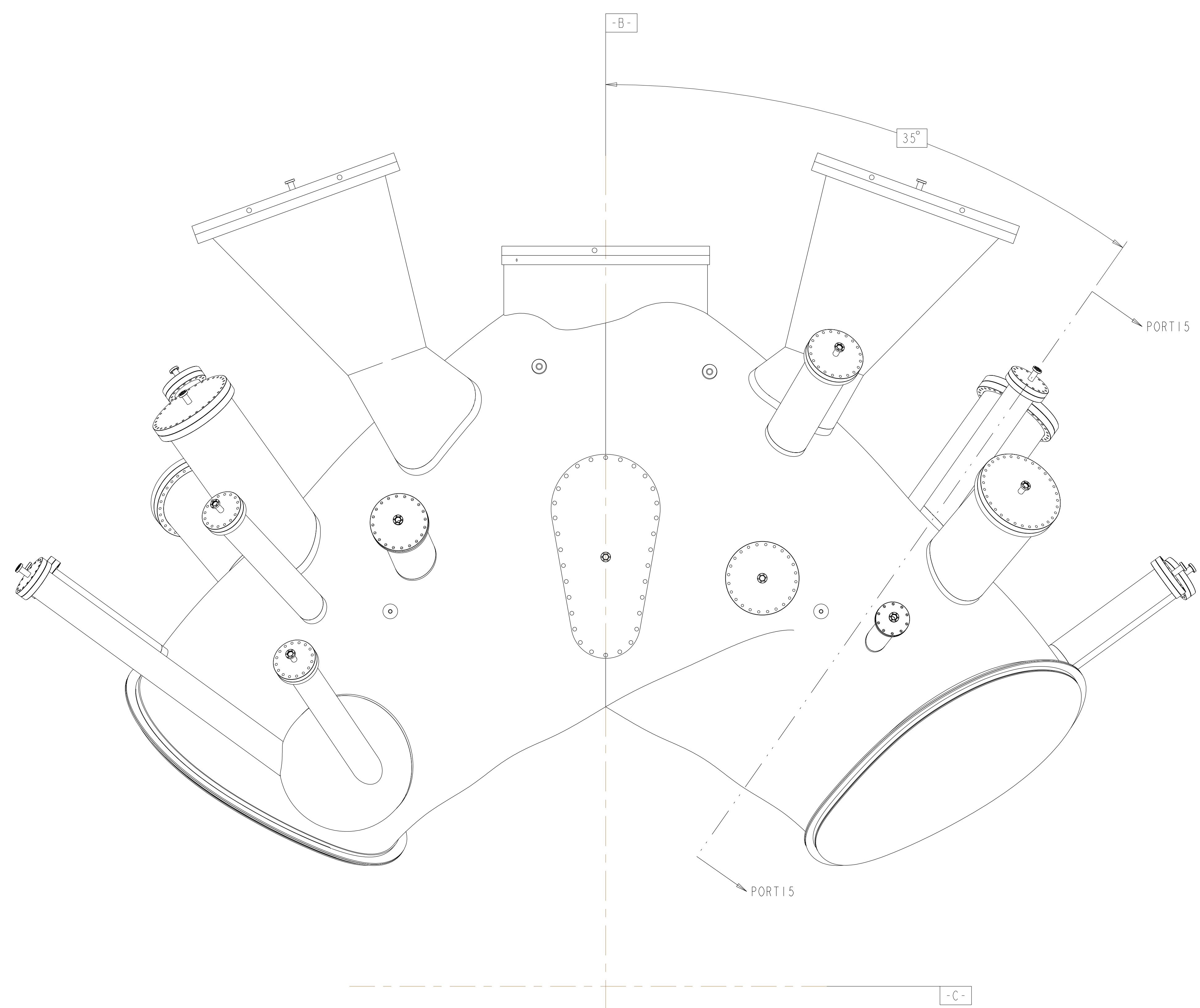

BOTTOM VIEW

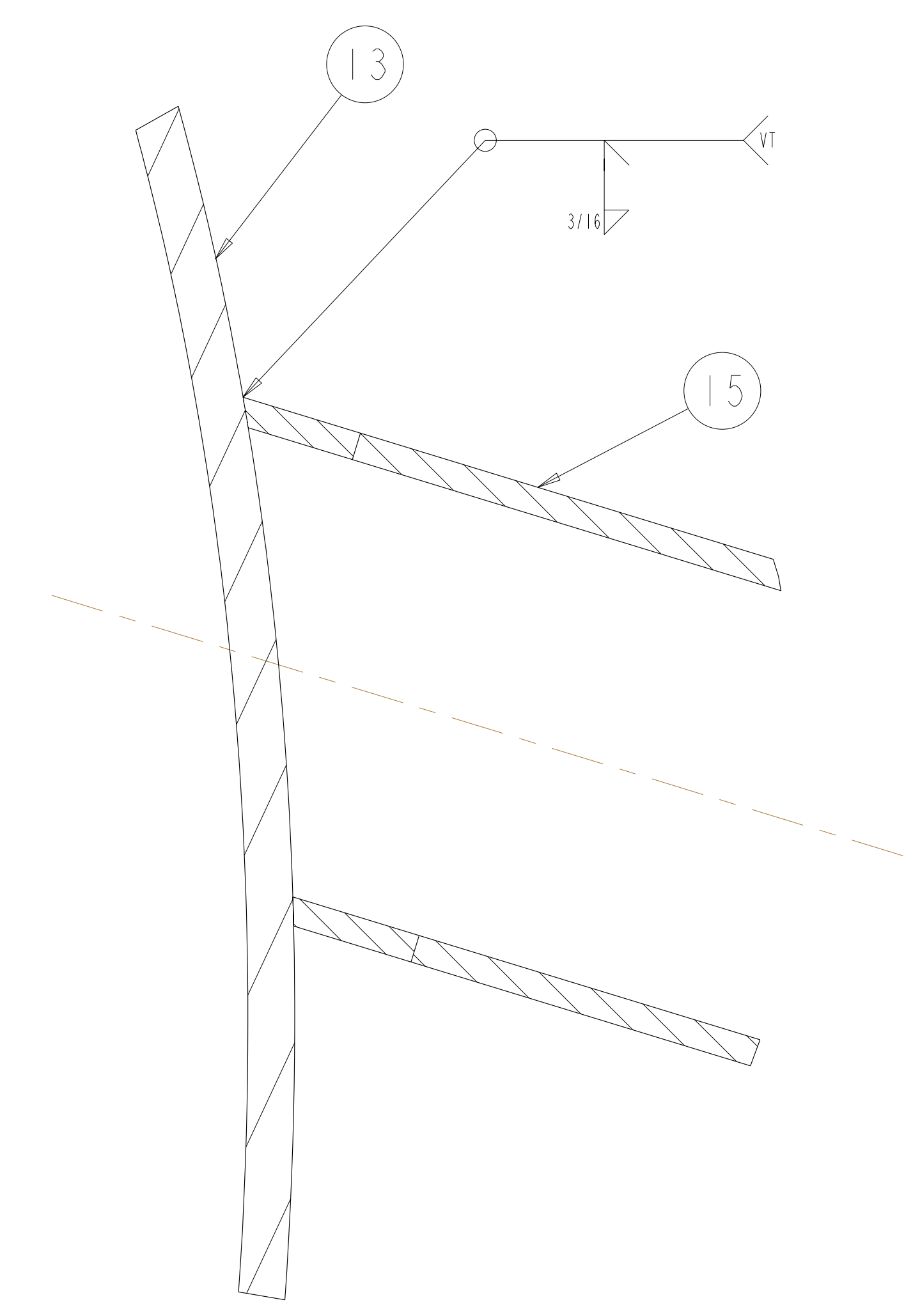

DETAIL X  
SCALE 1.00

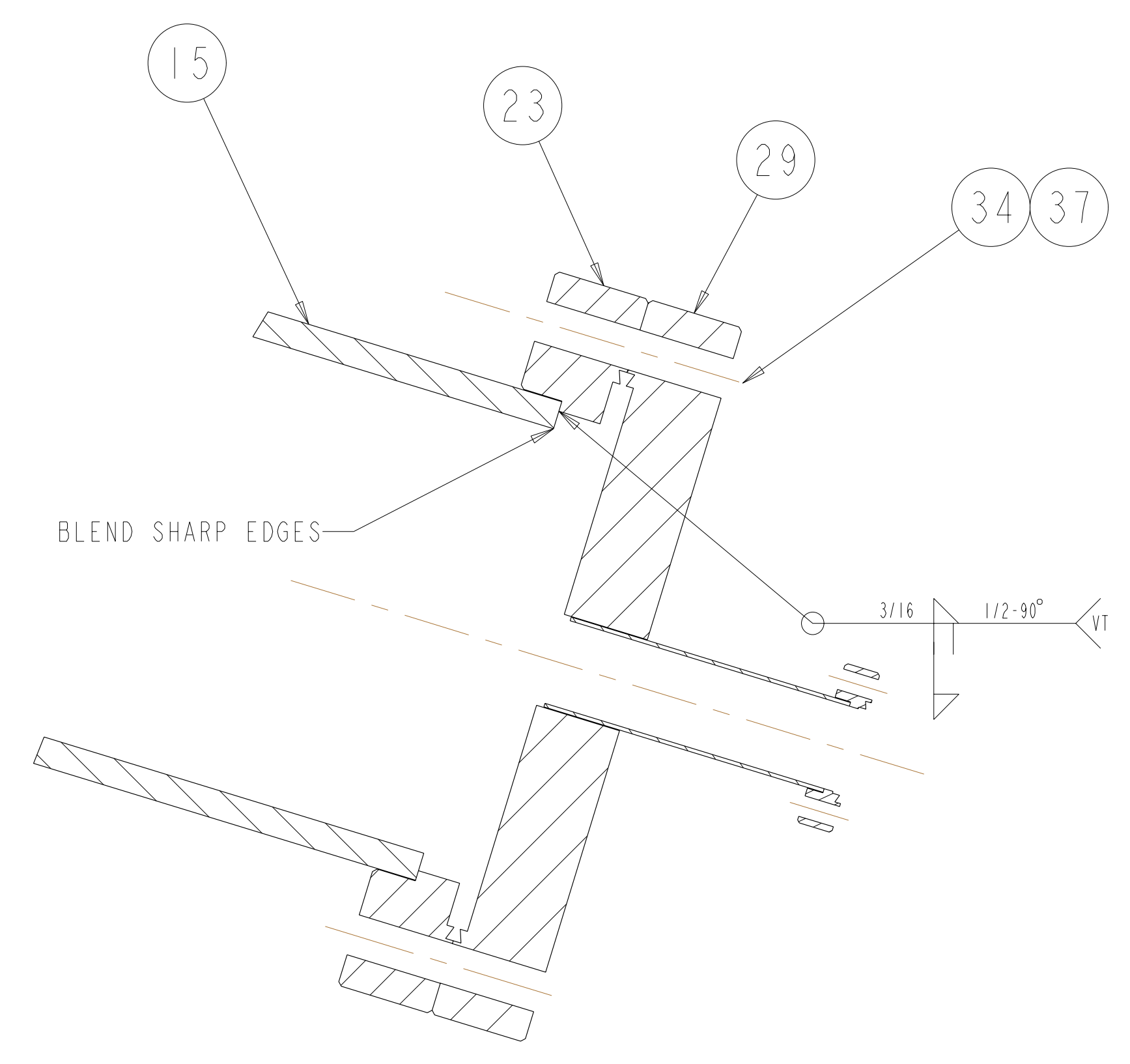

DETAIL Y  
SCALE 1.00

**Rev 2-e: ECN-5021 (RFD-12-017) approved alternate methods for welding the port extensions to the VVSA (See ECN-5021 for details). - Only applicable to VVSA #3 - VVSA #1 and #2 covered by NCR 19464.**

**ECN-5082.** Requirement originally included grooves to facilitate leak checking by vendor. However, vendor elected another means of leak checking and therefore the grooves are no longer required. Specifically, this ECN eliminated the leak checking groove on SE121-014 (Rev 1-c) and SE1221-091 (Rev 0-a). Additionally, this ECN added a missing weld symbol to SE121-004 (Sheets 4 through 19) for joining the port extensions to the vessel (Rev 2-d).  
**(See ECN-5082 for details)**

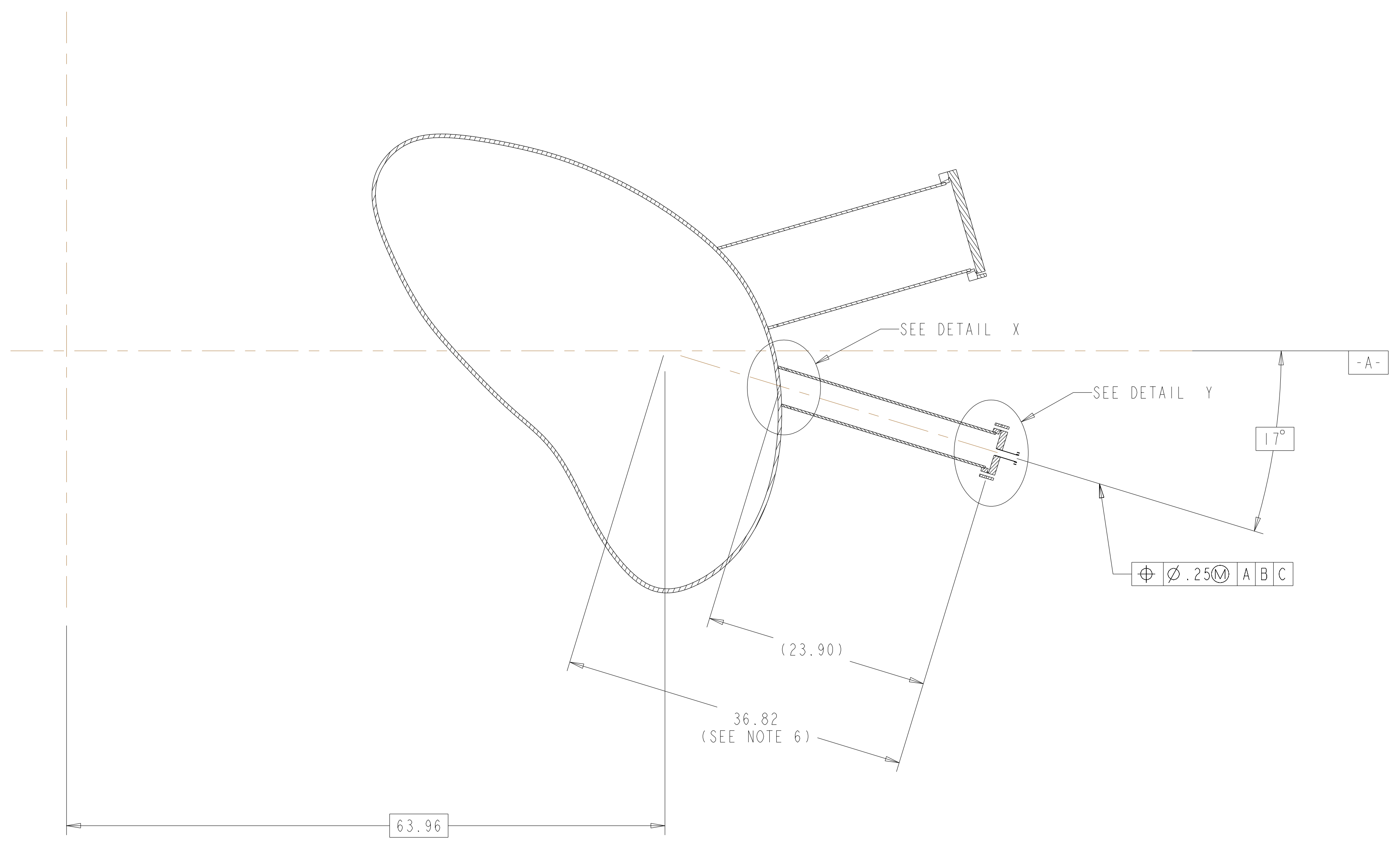

TYPICAL PORT 15A AND 15B  
SECTION PORT15-PORT15

**RELEASED FOR FABRICATION / INSTALLATION**  
 PPPL Drafting:

<b>UT-BATTELLE</b>		Oak Ridge National Laboratory managed for the DEPARTMENT OF ENERGY under U.S. GOVERNMENT contract DE-AC05-00OR22725 UT-BATTELLE, LLC, Oak Ridge, Tennessee						
PROJECT NAME								
NATIONAL COMPACT STELLARATOR EXPERIMENT								
VACUUM VESSEL								
PERIOD INSPECTION AND LEAK CHECK								
ASSEMBLY								
VERSION NO.	PLANT	BLDG	FL	SHT OF	TYPE	CLASS		
5	X-10	5700	3	14 19	A	U		
RELEASE LEVEL		SE120-004					REV	
Fabrication							2	

H  
G  
F  
E  
D  
C  
B  
A

FOR PARTS LIST AND NOTES SEE SHEET 1

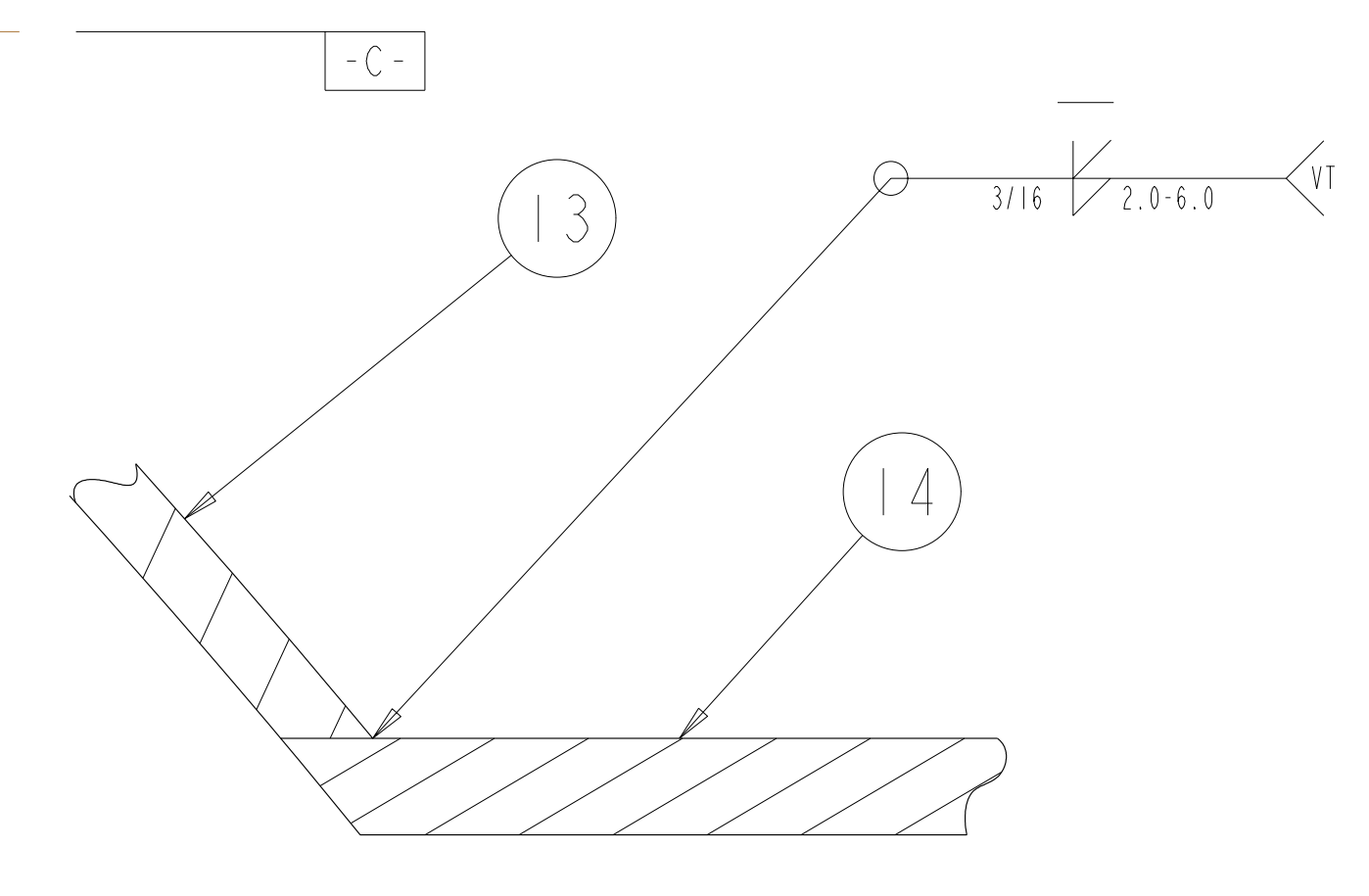
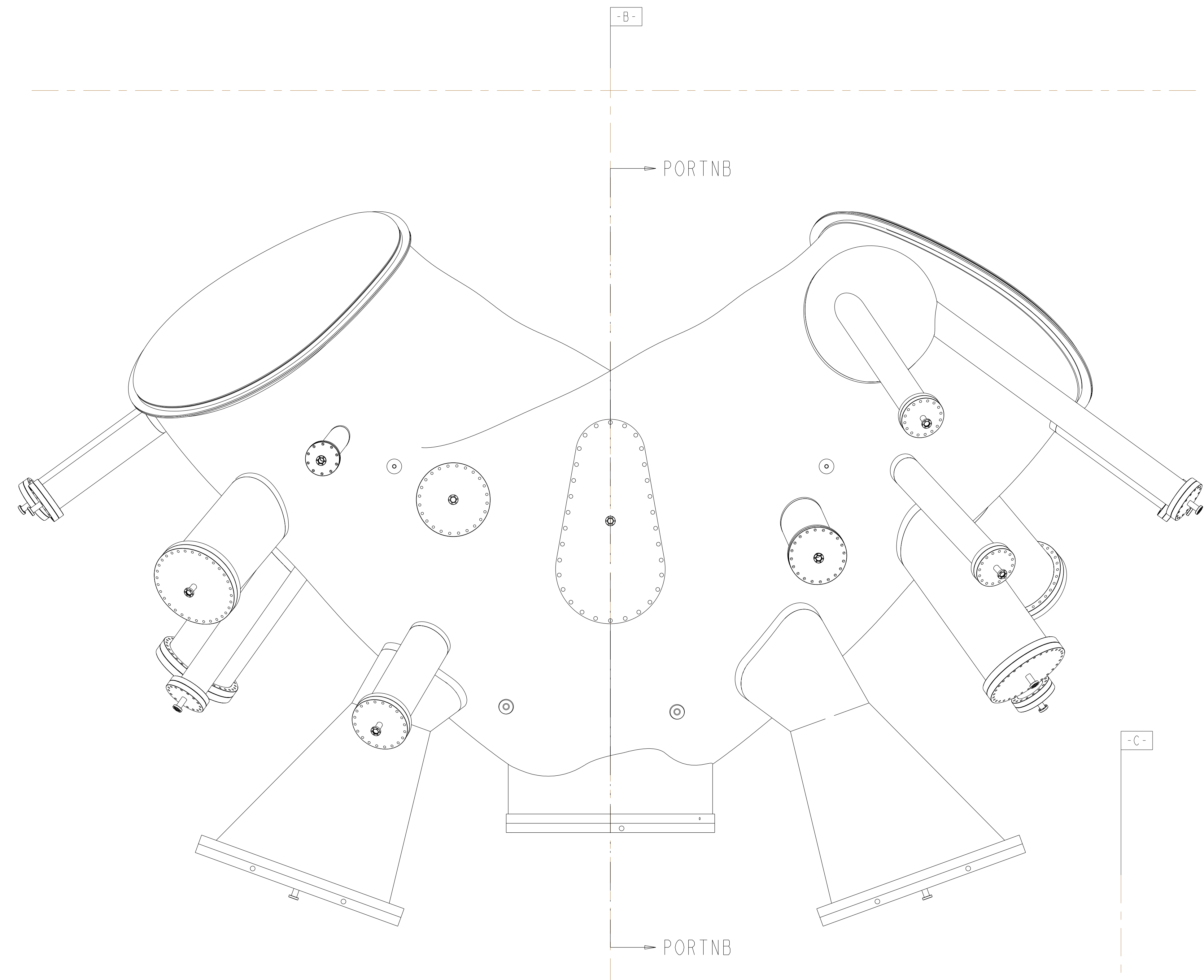

OPTIONAL WELD DETAIL

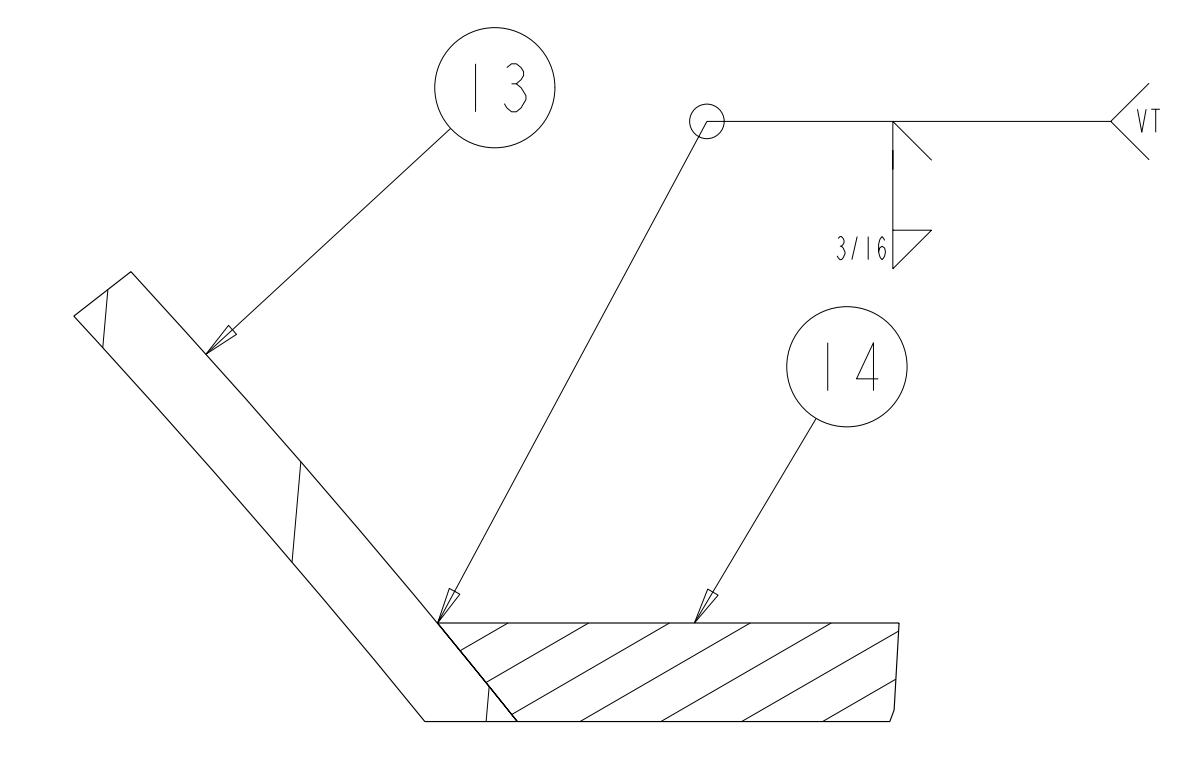

DETAIL X  
SCALE 1.00

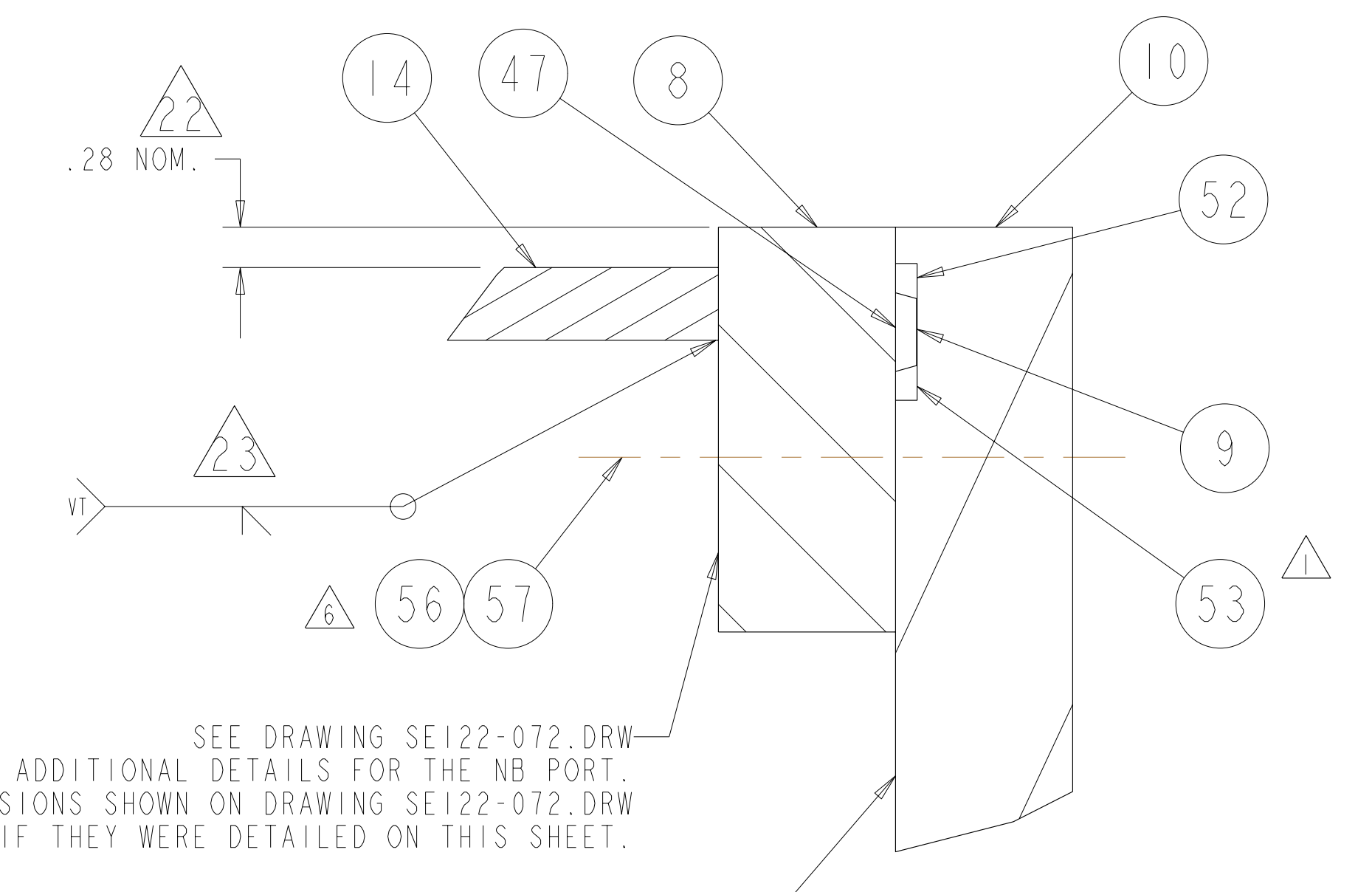

DETAIL Y  
SCALE 1.00

SEE DRAWING SE122-072.DRW FOR ADDITIONAL DETAILS FOR THE NB PORT DIMENSIONS SHOWN ON DRAWING SE122-072.DRW APPLY AS IF THEY WERE DETAILED ON THIS SHEET.

SEE DRAWING SE122-172.DRW FOR ADDITIONAL DETAILS FOR THE NB PORT DIMENSIONS SHOWN ON DRAWING SE122-172.DRW APPLY AS IF THEY WERE DETAILED ON THIS SHEET.

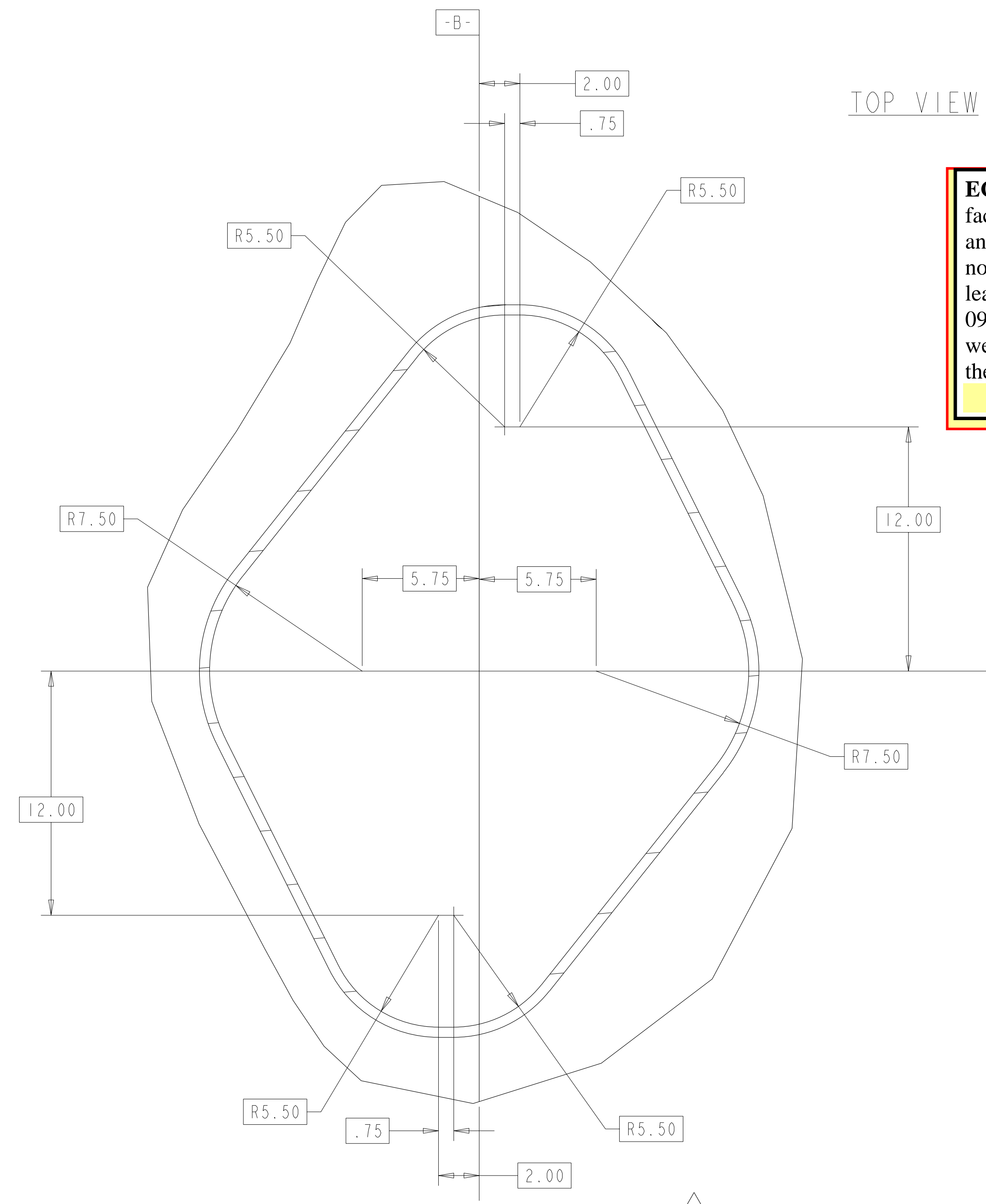

TOP VIEW

**ECN-5082.** Requirement originally included grooves to facilitate leak checking by vendor. However, vendor elected another means of leak checking and therefore the grooves are no longer required. Specifically, this ECN eliminated the leak checking groove on SE121-014 (Rev 1-c) and SE1221-091 (Rev 0-a). Additionally, this ECN added a missing weld symbol to SE121-004 (Sheets 4 through 19) for joining the port extensions to the vessel (Rev 2-d).  
 (See ECN-5082 for details)

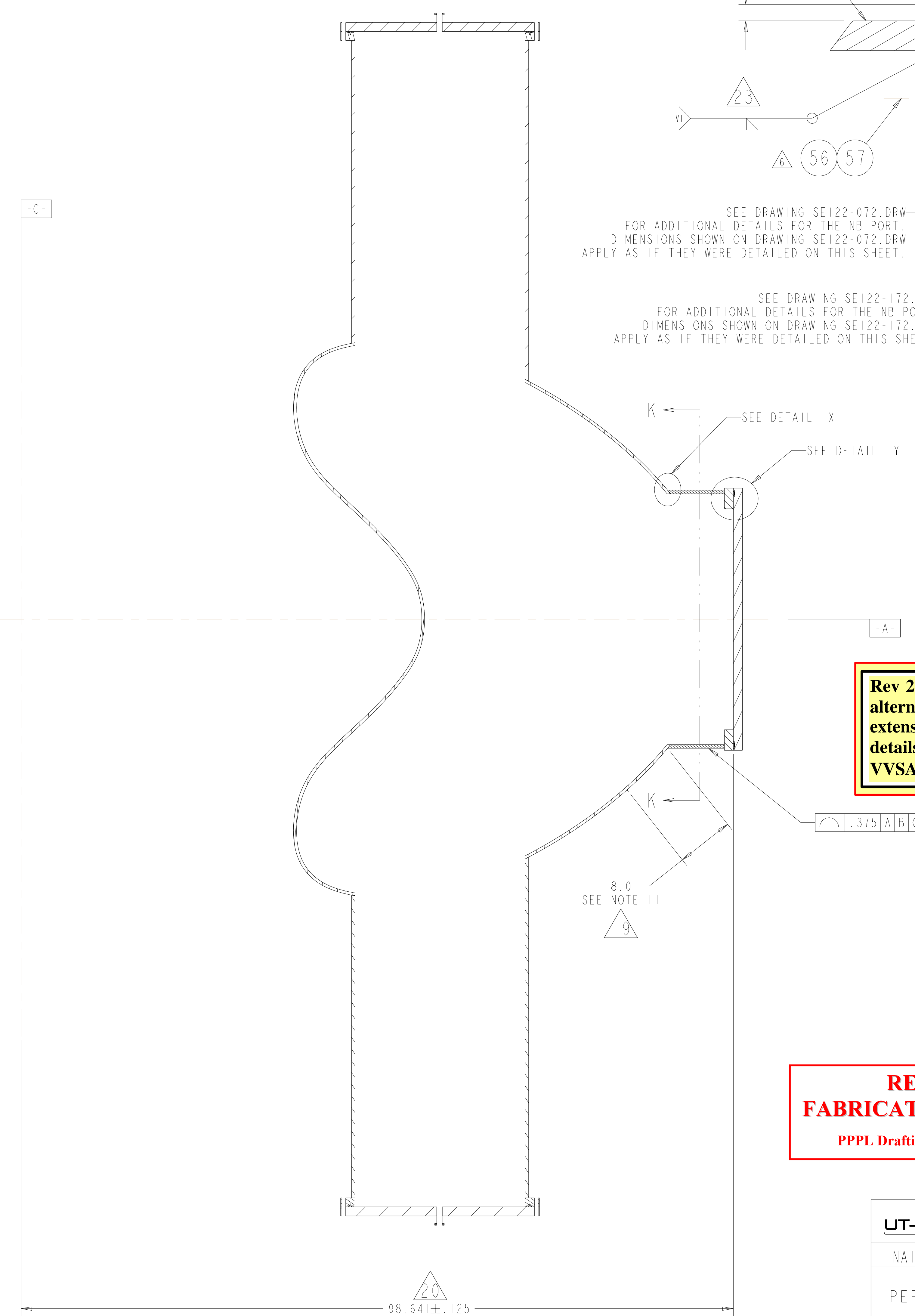

SECTION PORTNB-PORTNB

**Rev 2-e: ECN-5021 (RFD-12-017) approved alternate methods for welding the port extensions to the VVSA (See ECN-5021 for details). - Only applicable to VVSA #3 - VVSA #1 and #2 covered by NCR 19464.**

**RELEASED FOR FABRICATION / INSTALLATION**  
 PPPL Drafting:

SECTION K-K  
SCALE 0.25

Oak Ridge National Laboratory managed for the DEPARTMENT OF ENERGY under U.S. GOVERNMENT contract DE-AC05-00OR22725 UT-BATTELLE, LLC, Oak Ridge, Tennessee PROJECT NAME						
NATIONAL COMPACT STELLARATOR EXPERIMENT VACUUM VESSEL PERIOD INSPECTION AND LEAK CHECK ASSEMBLY						
VERSION NO.	PLANT	BLDG	FL	SHT OF	TYPE	CLASS
5	X-10	5700	3	15	A	U
RELEASE LEVEL						REV
Fabrication	SE120-004					2

SE120-004

FOR PARTS LIST AND NOTES SEE SHEET 1.

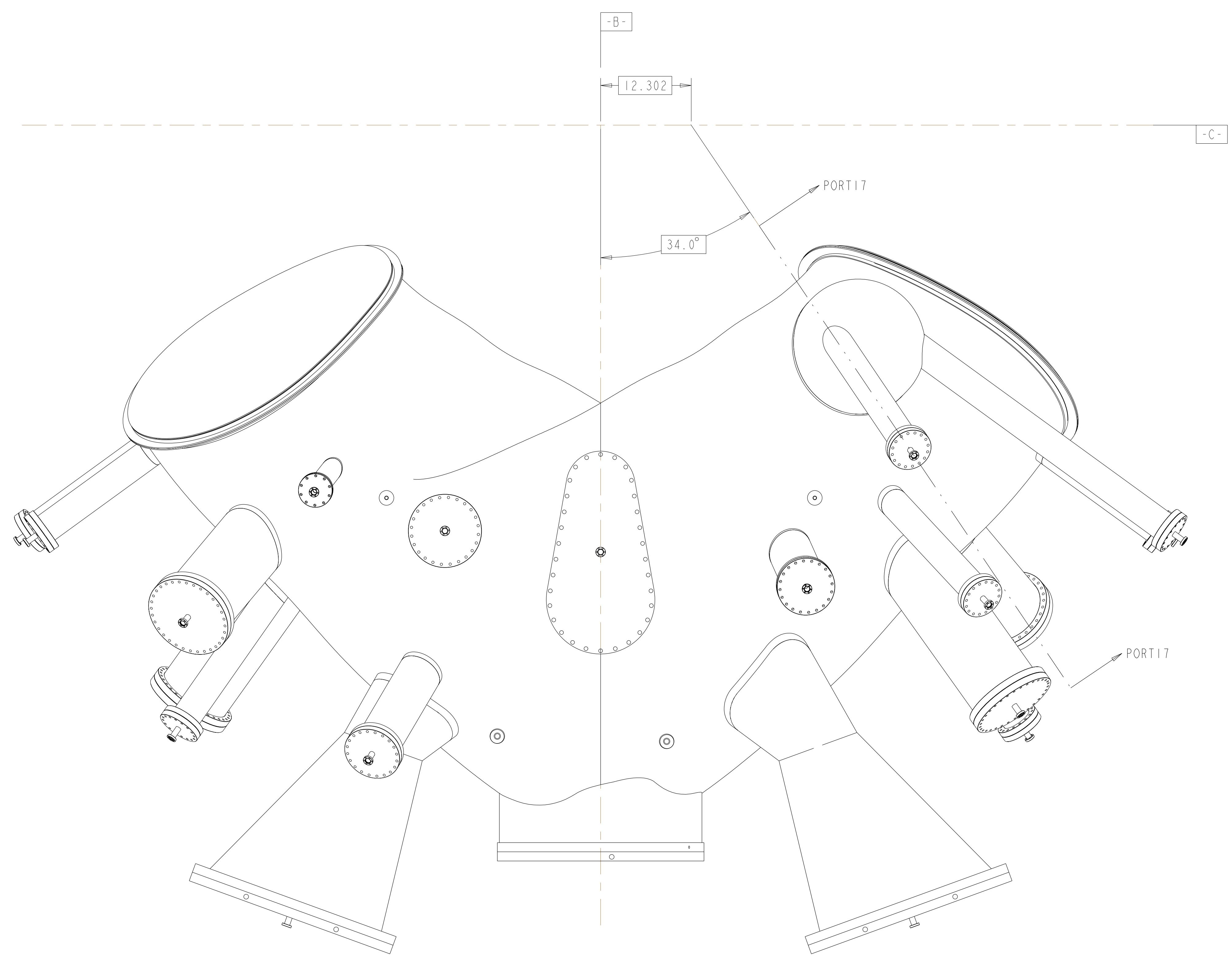

TOP VIEW

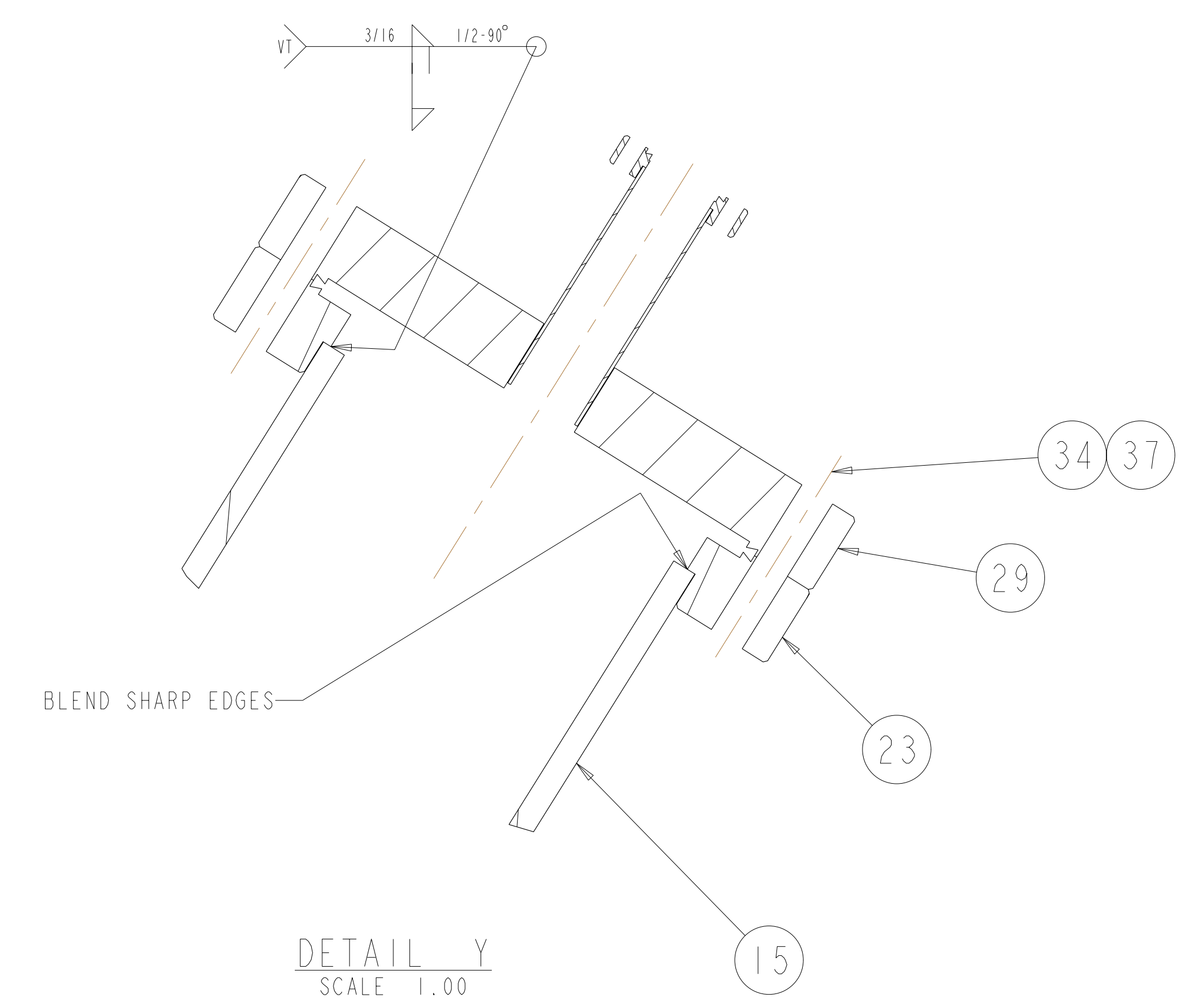

DETAIL Y  
SCALE 1.00

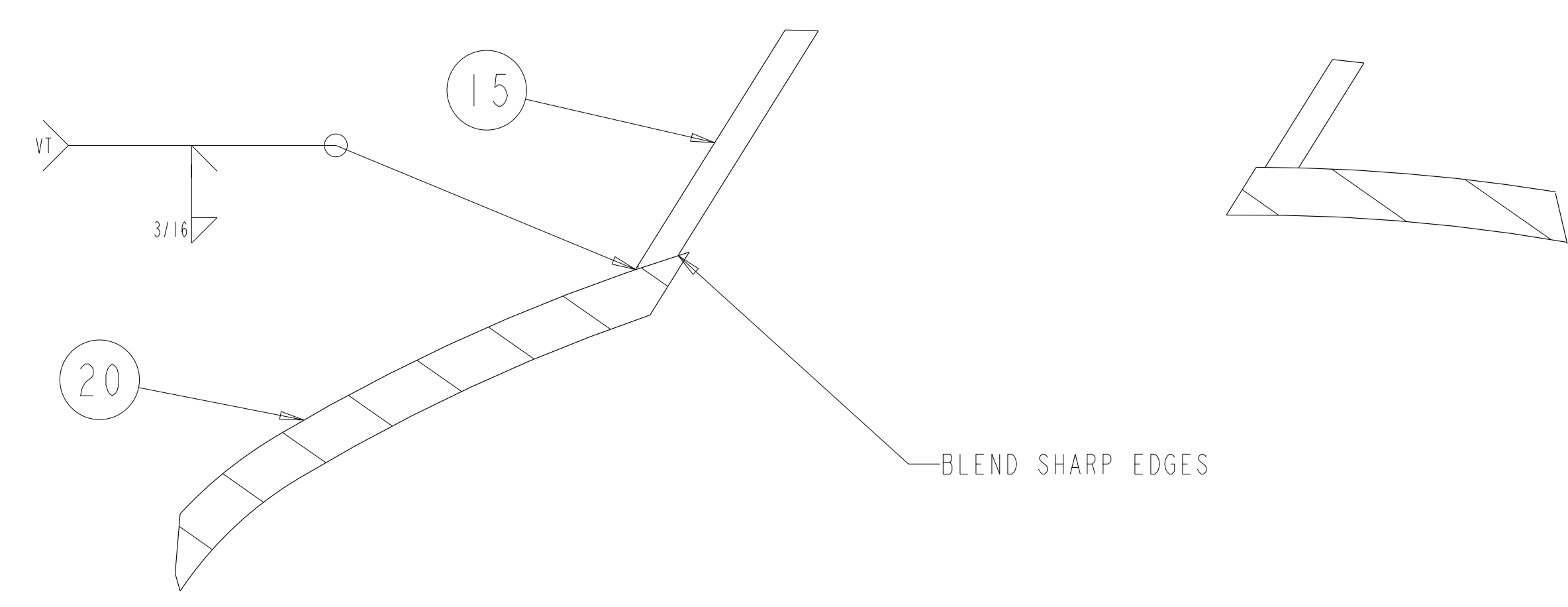

DETAIL X  
SCALE 1.00

**ECN-5082.** Requirement originally included grooves to facilitate leak checking by vendor. However, vendor elected another means of leak checking and therefore the grooves are no longer required. Specifically, this ECN eliminated the leak checking groove on SE121-014 (Rev 1-c) and SE1221-091 (Rev 0-a). Additionally, this ECN added a missing weld symbol to SE121-004 (Sheets 4 through 19) for joining the port extensions to the vessel (Rev 2-d).  
 (See ECN-5082 for details)

**Rev 2-e: ECN-5021 (RFD-12-017) approved alternate methods for welding the port extensions to the VVSA (See ECN-5021 for details). - Only applicable to VVSA #3 - VVSA #1 and #2 covered by NCR 19464.**

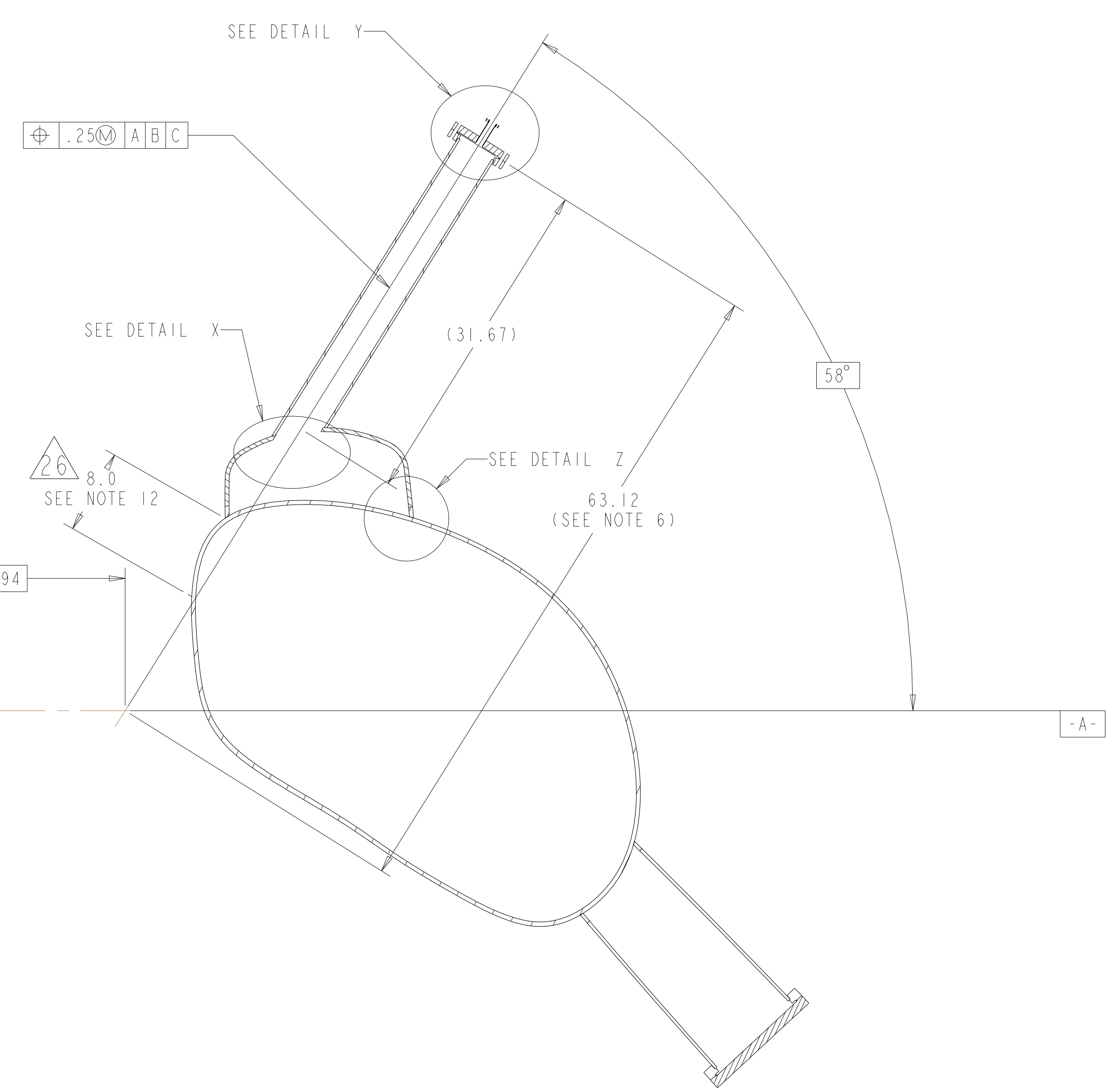

TYPICAL PORT 17A AND 17B SECTION PORT17-PORT17

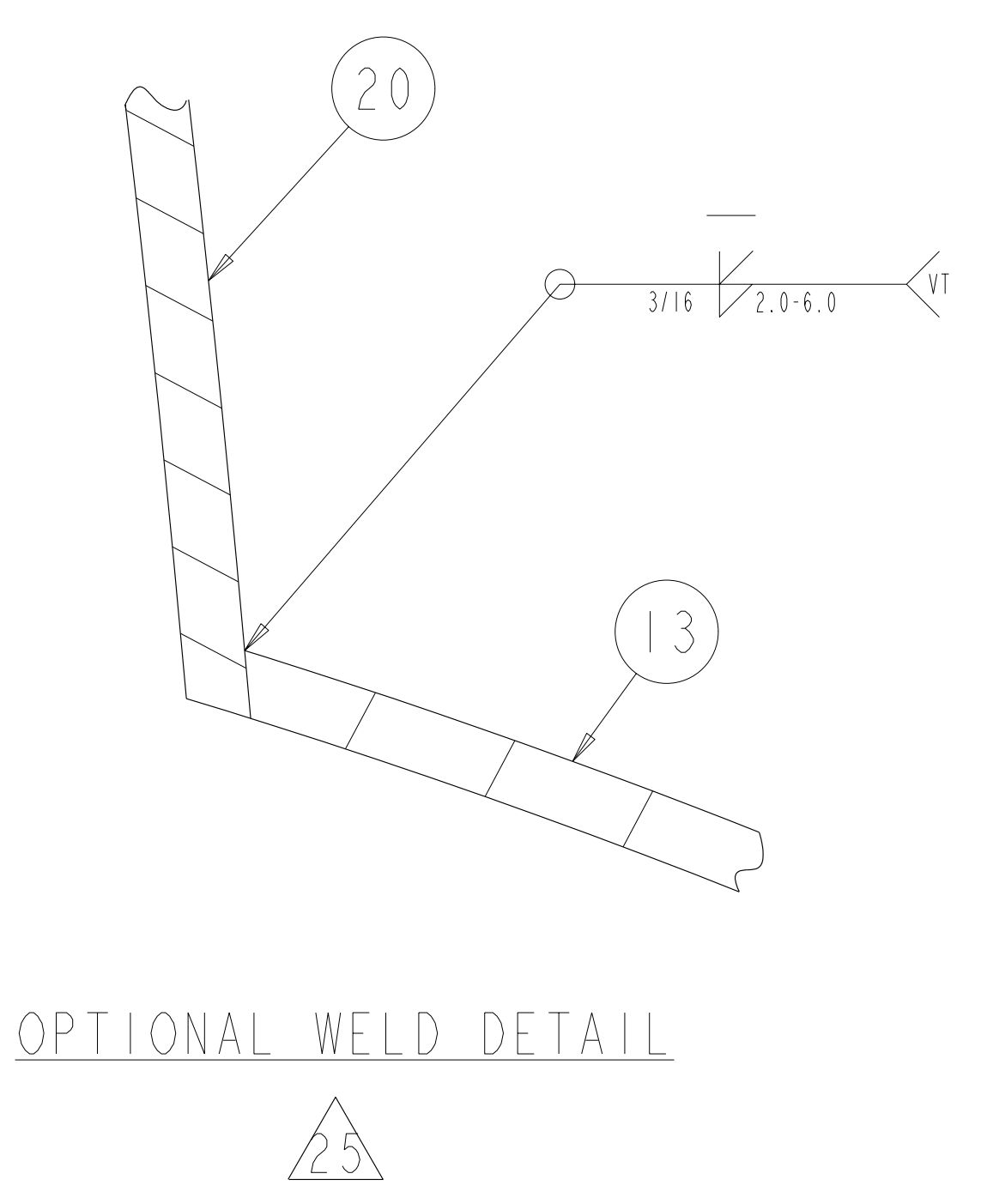

OPTIONAL WELD DETAIL

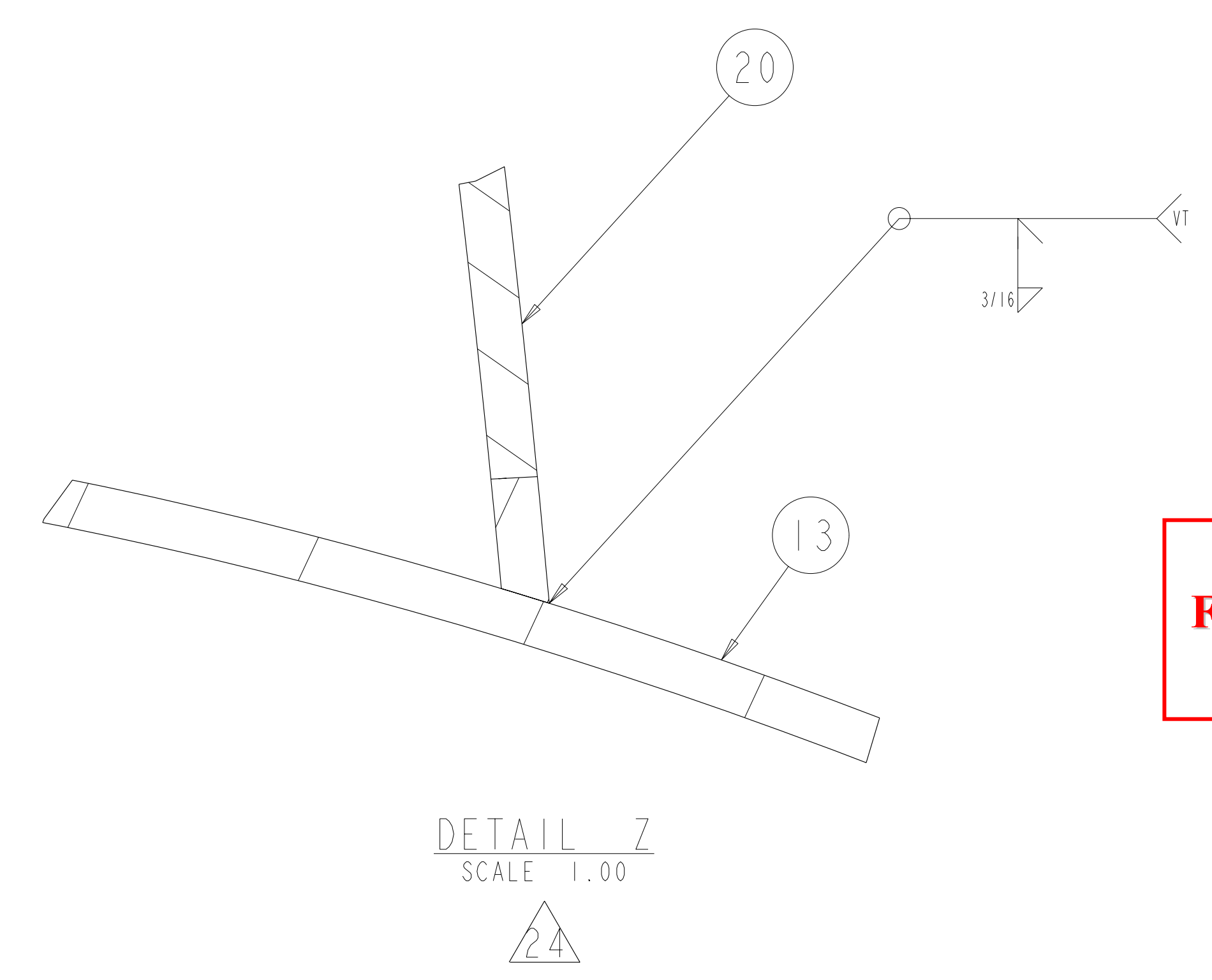

DETAIL Z  
SCALE 1.00

**RELEASED FOR FABRICATION / INSTALLATION**  
 PPPL Drafting:

UT-BATTELLE		Oak Ridge National Laboratory managed for the DEPARTMENT OF ENERGY under U.S. GOVERNMENT contract DE-AC05-00OR22725 UT-BATTELLE, LLC, Oak Ridge, Tennessee					
PROJECT NAME							
NATIONAL COMPACT STELLARATOR EXPERIMENT							
VACUUM VESSEL							
PERIOD INSPECTION AND LEAK CHECK ASSEMBLY							
VERSION NO.	PLANT	BLDG	FL	SHT OF	TYPE	CLASS	
5	X-10	5700	3	16	19	A	U
RELEASE LEVEL		SE120-004					REV
Fabrication							2

H  
G  
F  
E  
D  
C  
B  
A





FOR PARTS LIST AND NOTES SEE SHEET 1.

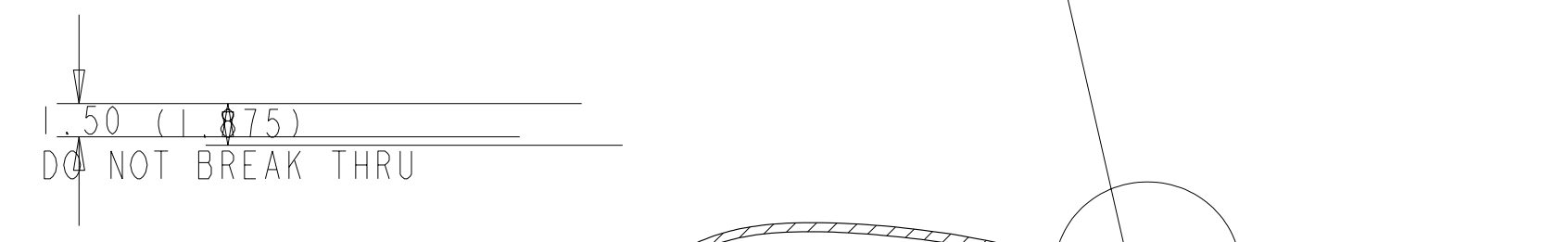
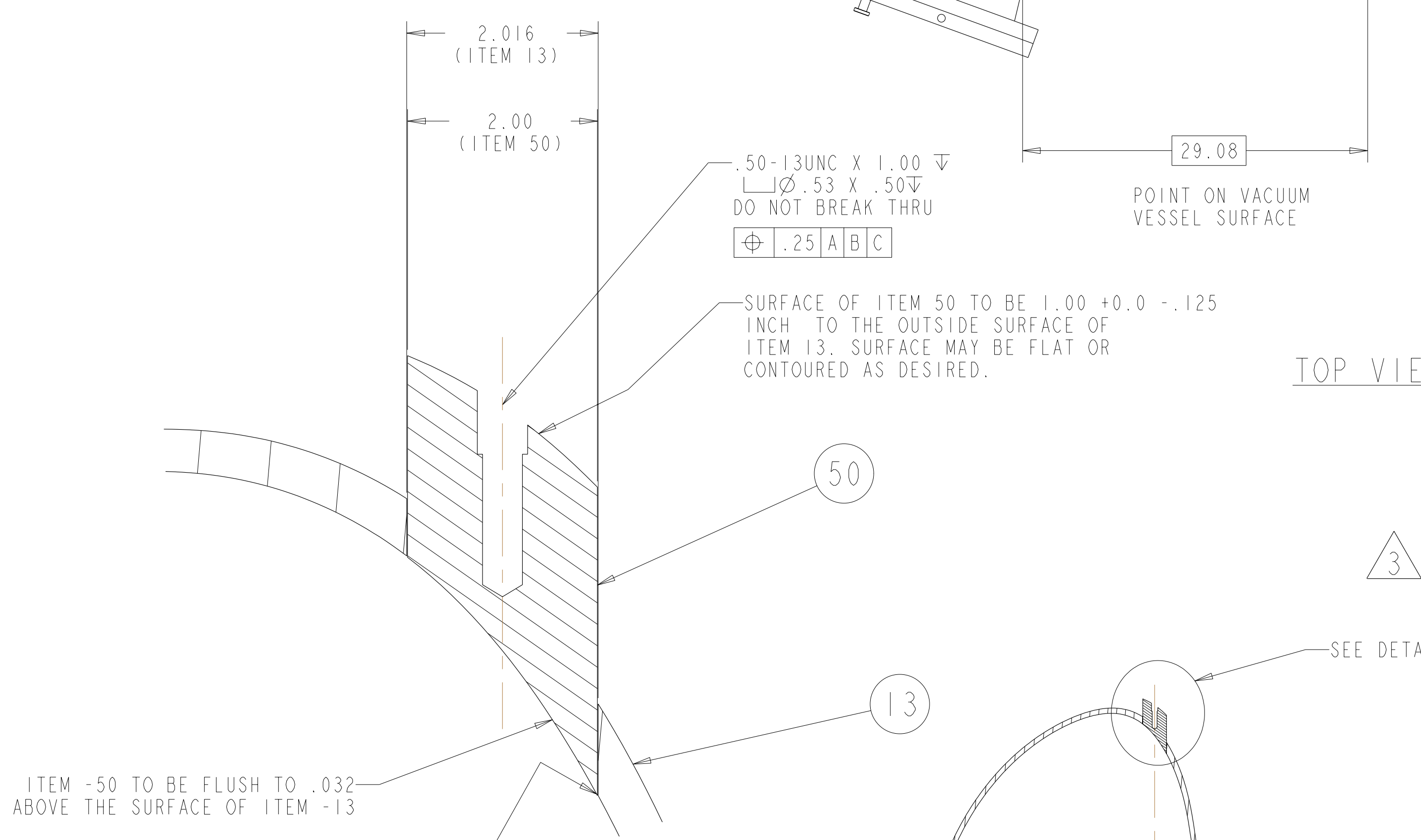
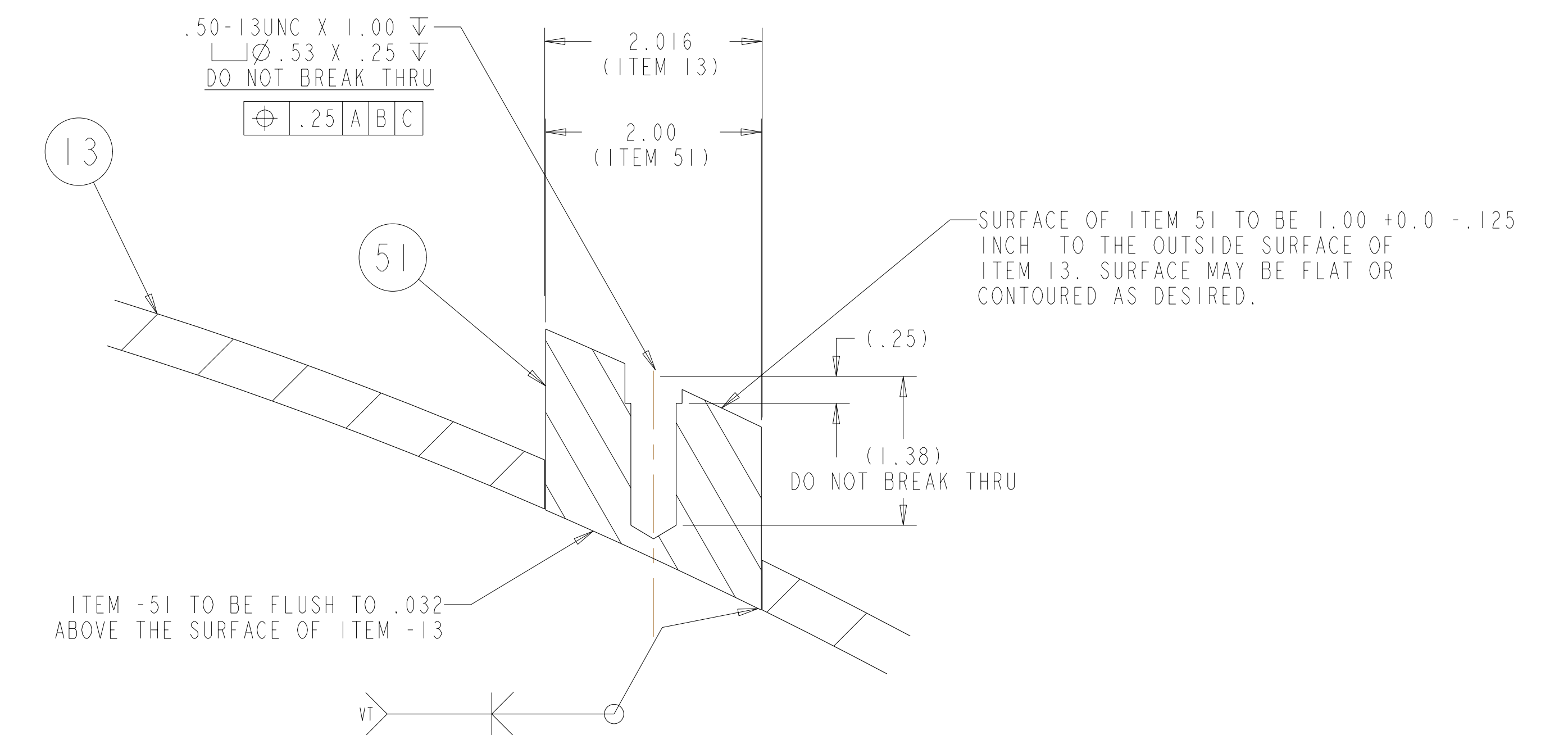
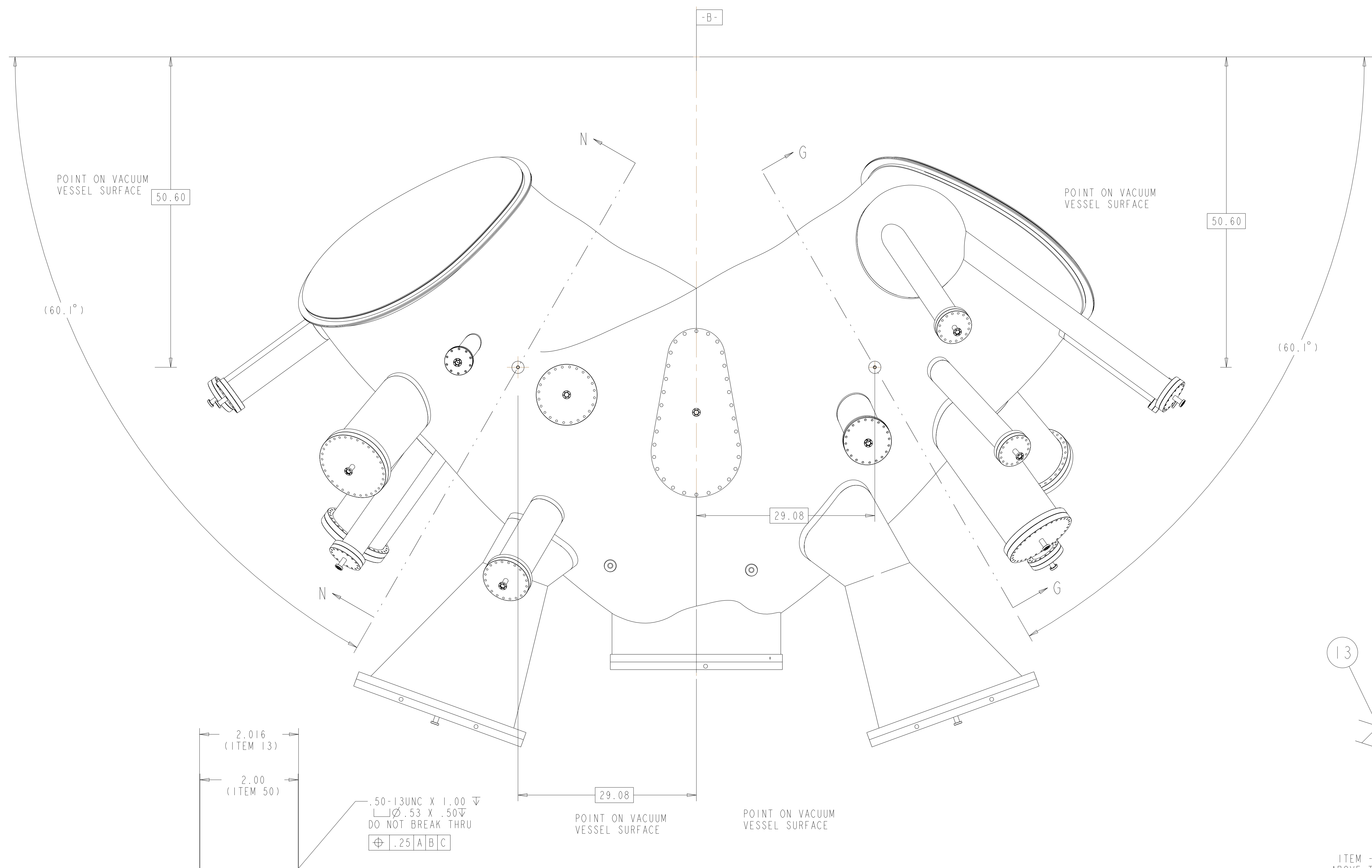

TOP VIEW

DETAIL X  
TYPICAL 2 PLACES  
SCALE 1.00

DETAIL Z  
SCALE 1.00

SECTION N-N

SECTION G-G

**Rev 2-e: ECN-5021 (RFD-12-017) approved alternate methods for welding the port extensions to the VVSA (See ECN-5021 for details). - Only applicable to VVSA #3 - VVSA #1 and #2 covered by NCR 19464.**

**ECN-5082. Requirement originally included grooves to facilitate leak checking by vendor. However, vendor elected another means of leak checking and therefore the grooves are no longer required. Specifically, this ECN eliminated the leak checking groove on SE121-014 (Rev 1-c) and SE1221-091 (Rev 0-a). Additionally, this ECN added a missing weld symbol to SE121-004 (Sheets 4 through 19) for joining the port extensions to the vessel (Rev 2-d). (See ECN-5082 for details)**

**RELEASED FOR FABRICATION / INSTALLATION**  
PPPL Drafting:

UT-BATTELLE		Oak Ridge National Laboratory managed for the DEPARTMENT OF ENERGY under U.S. GOVERNMENT contract DE-AC05-00OR22725 UT-BATTELLE, LLC. Oak Ridge, Tennessee	
PROJECT NAME			
NATIONAL COMPACT STELLARATOR EXPERIMENT			
VACUUM VESSEL PERIOD INSPECTION AND LEAK CHECK ASSEMBLY			
VERSION NO.	PLANT	BLDG	FL SHT OF TYPE CLASS
3+	X-10	5700	3 8 19 A U
RELEASE LEVEL		REV	
Fabrication		SE120-004 2	

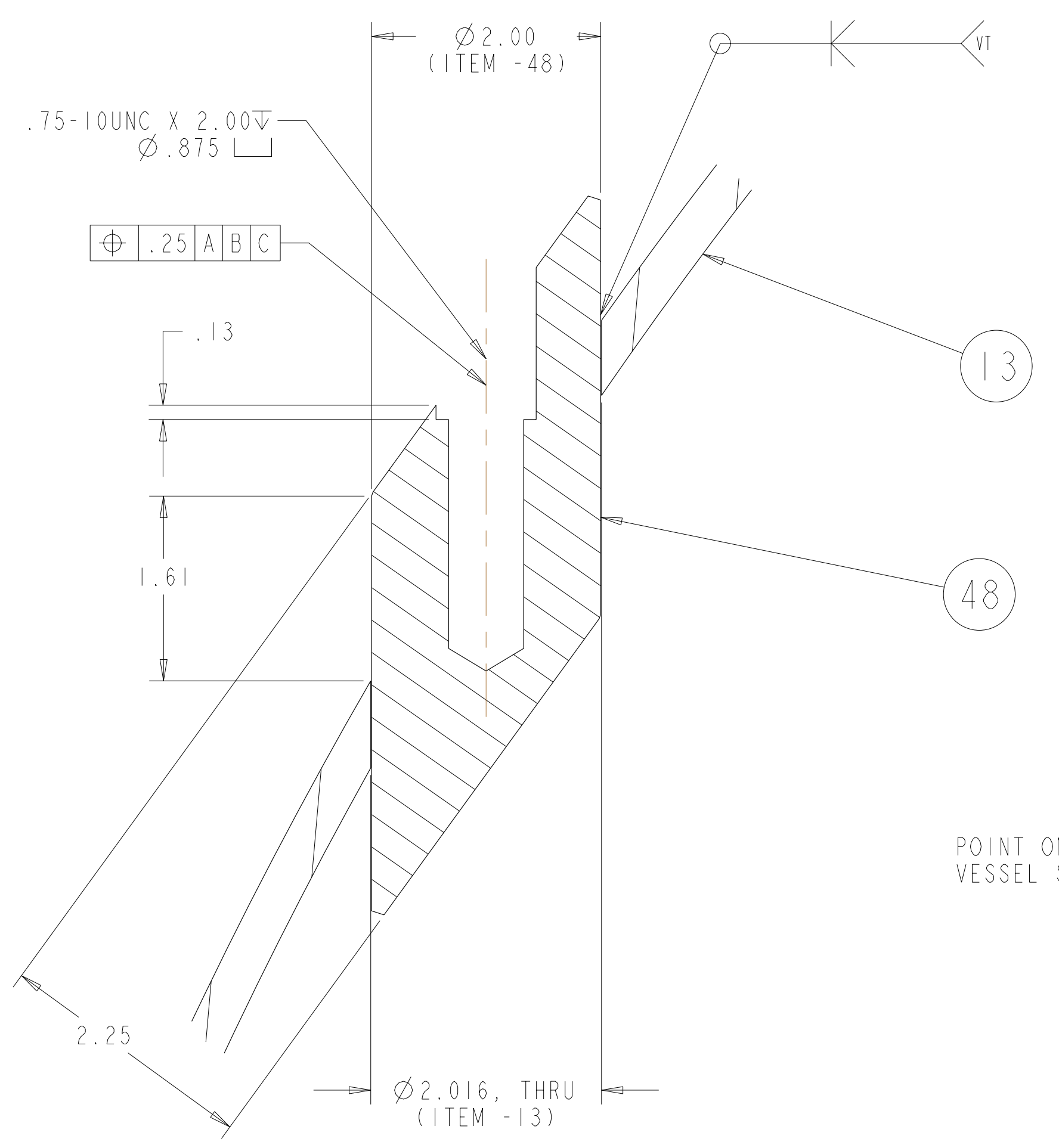

DETAIL W  
SCALE 1.00

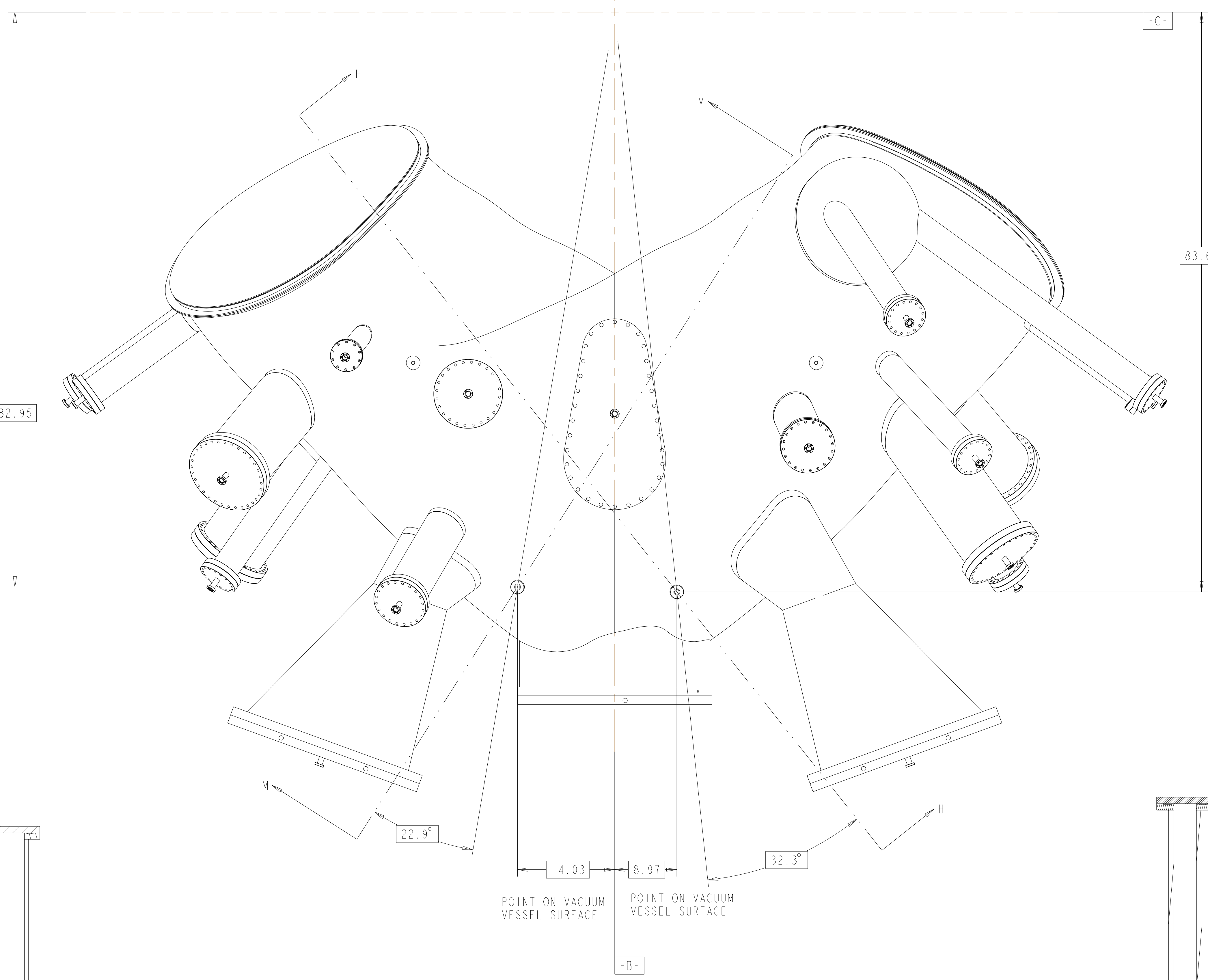

TOP VIEW

FOR PARTS LIST AND NOTES SEE SHEET 1.

POINT ON VACUUM VESSEL SURFACE

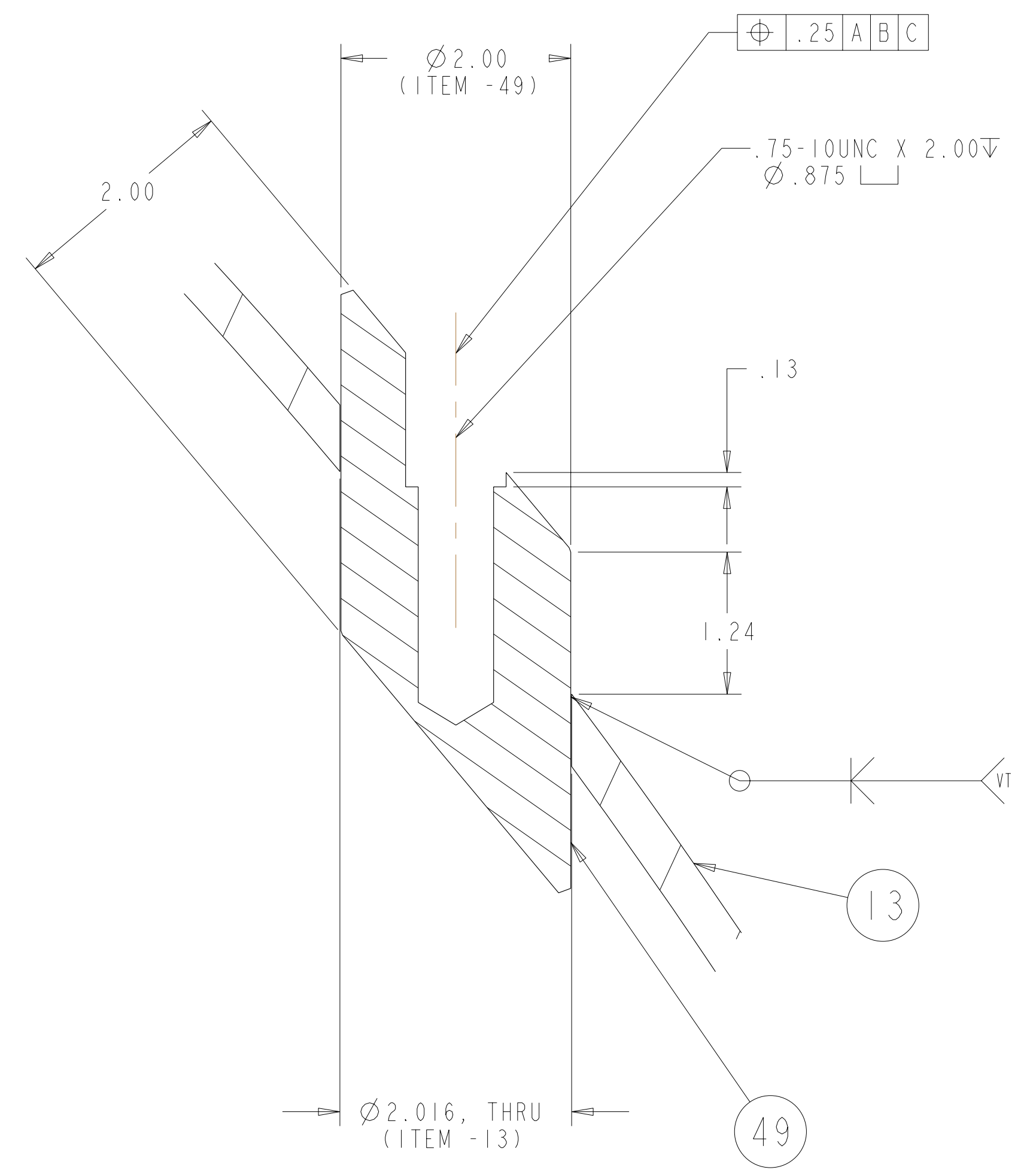

DETAIL Y  
SCALE 1.00

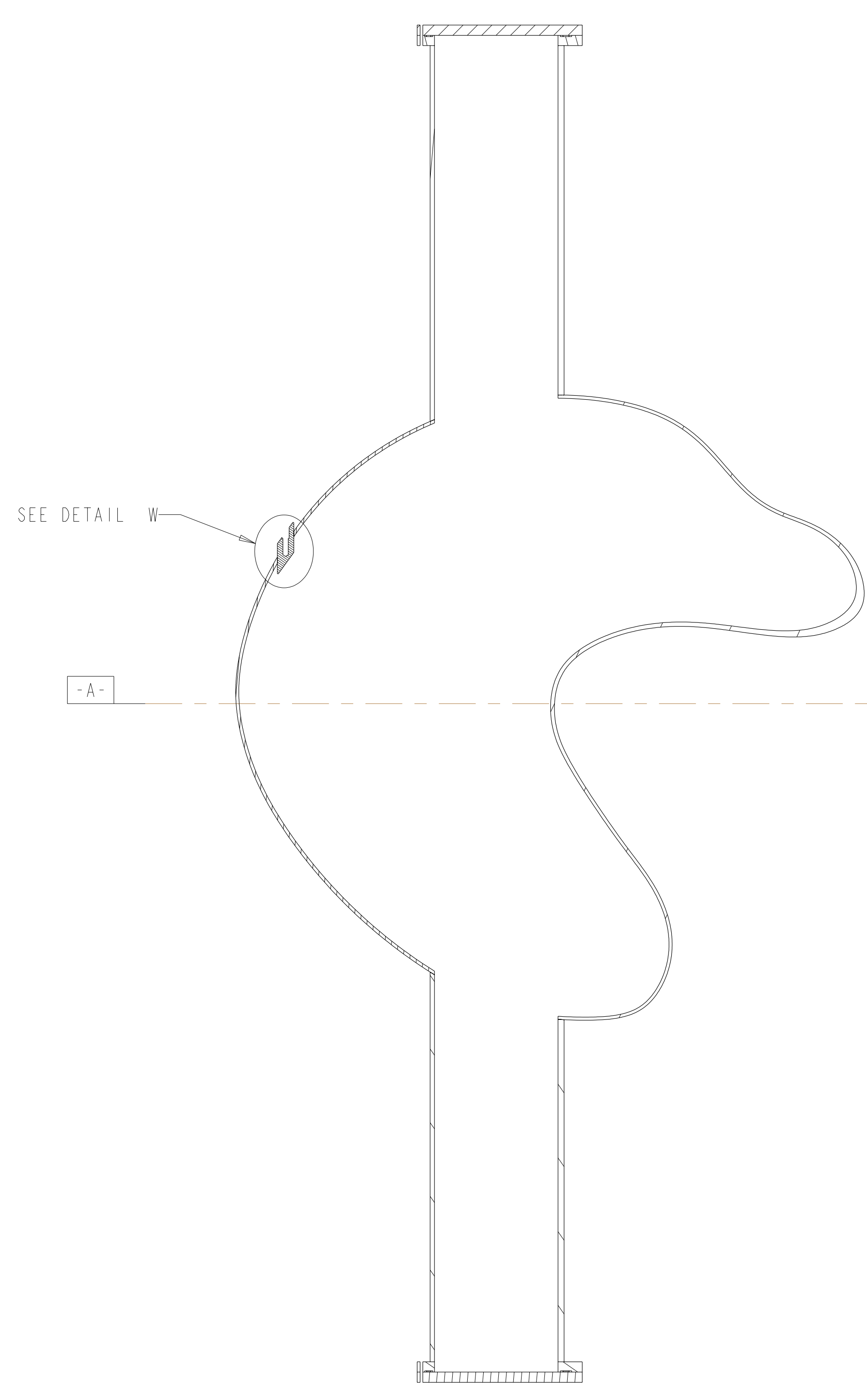

SECTION M-M  
SCALE 0.09

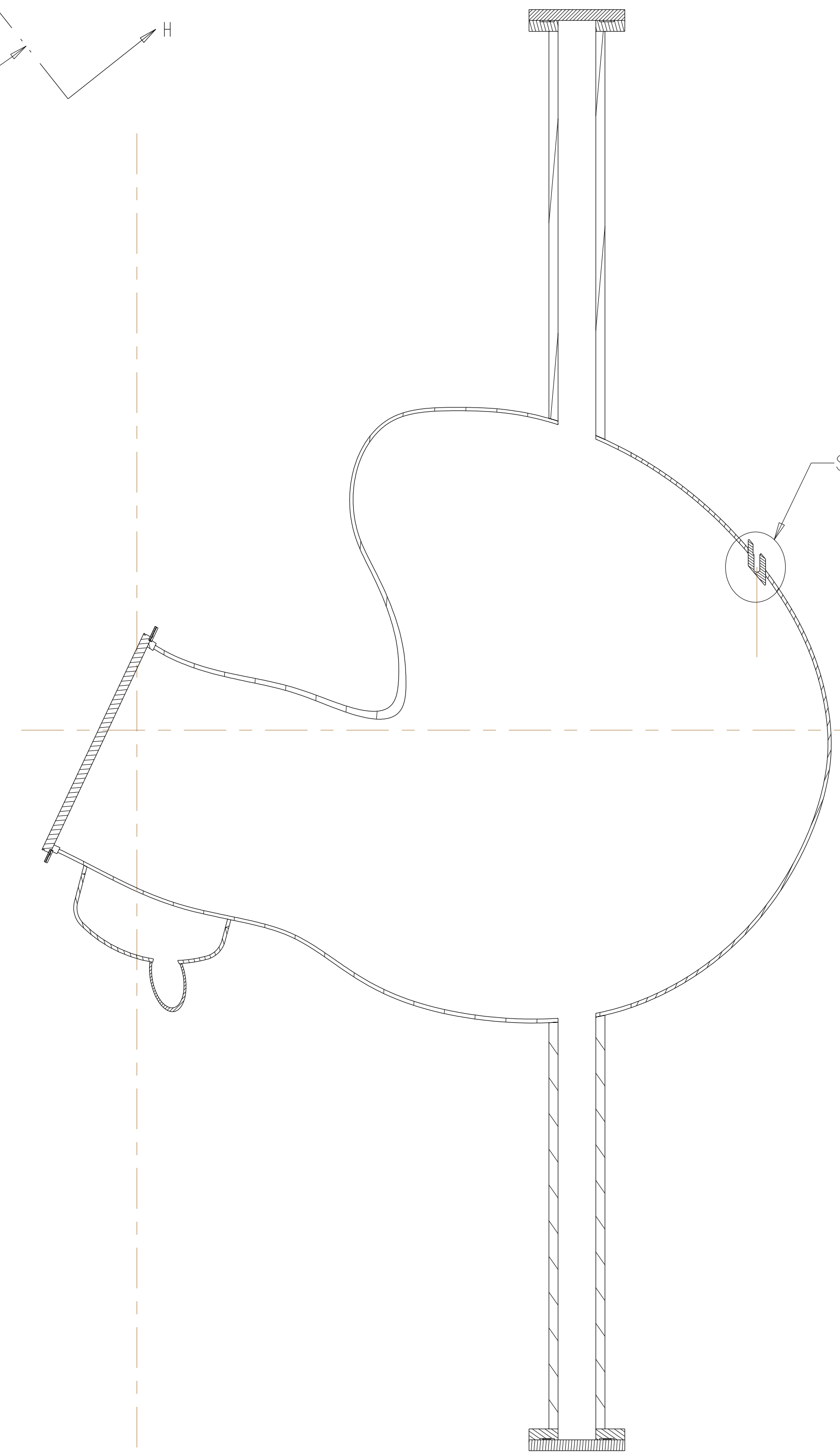

SECTION H-H  
SCALE 0.09

**ECN-5082.** Requirement originally included grooves to facilitate leak checking by vendor. However, vendor elected another means of leak checking and therefore the grooves are no longer required. Specifically, this ECN eliminated the leak checking groove on SE121-014 (Rev 1-c) and SE1221-091 (Rev 0-a). Additionally, this ECN added a missing weld symbol to SE121-004 (Sheets 4 through 19) for joining the port extensions to the vessel (Rev 2-d).  
**(See ECN-5082 for details)**

**Rev 2-e: ECN-5021 (RFD-12-017) approved alternate methods for welding the port extensions to the VVSA (See ECN-5021 for details). - Only applicable to VVSA #3 - VVSA #1 and #2 covered by NCR 19464.**

**RELEASED FOR FABRICATION / INSTALLATION**  
PPPL Drafting:

Oak Ridge National Laboratory managed for the DEPARTMENT OF ENERGY under U.S. GOVERNMENT CONTRACT DE-AC05-00OR22725 UT-BATTELLE, LLC, Oak Ridge, Tennessee PROJECT NAME:							
NATIONAL COMPACT STELLARATOR EXPERIMENT VACUUM VESSEL PERIOD INSPECTION AND LEAK CHECK ASSEMBLY							
VERSION NO.	PLANT	BLDG	FL	SHT OF	TYPE	CLASS	
5	X-10	5700	3	19 19	A	U	
RELEASE LEVEL	SE120-004						REV
Fabrication							2

SE120-004