

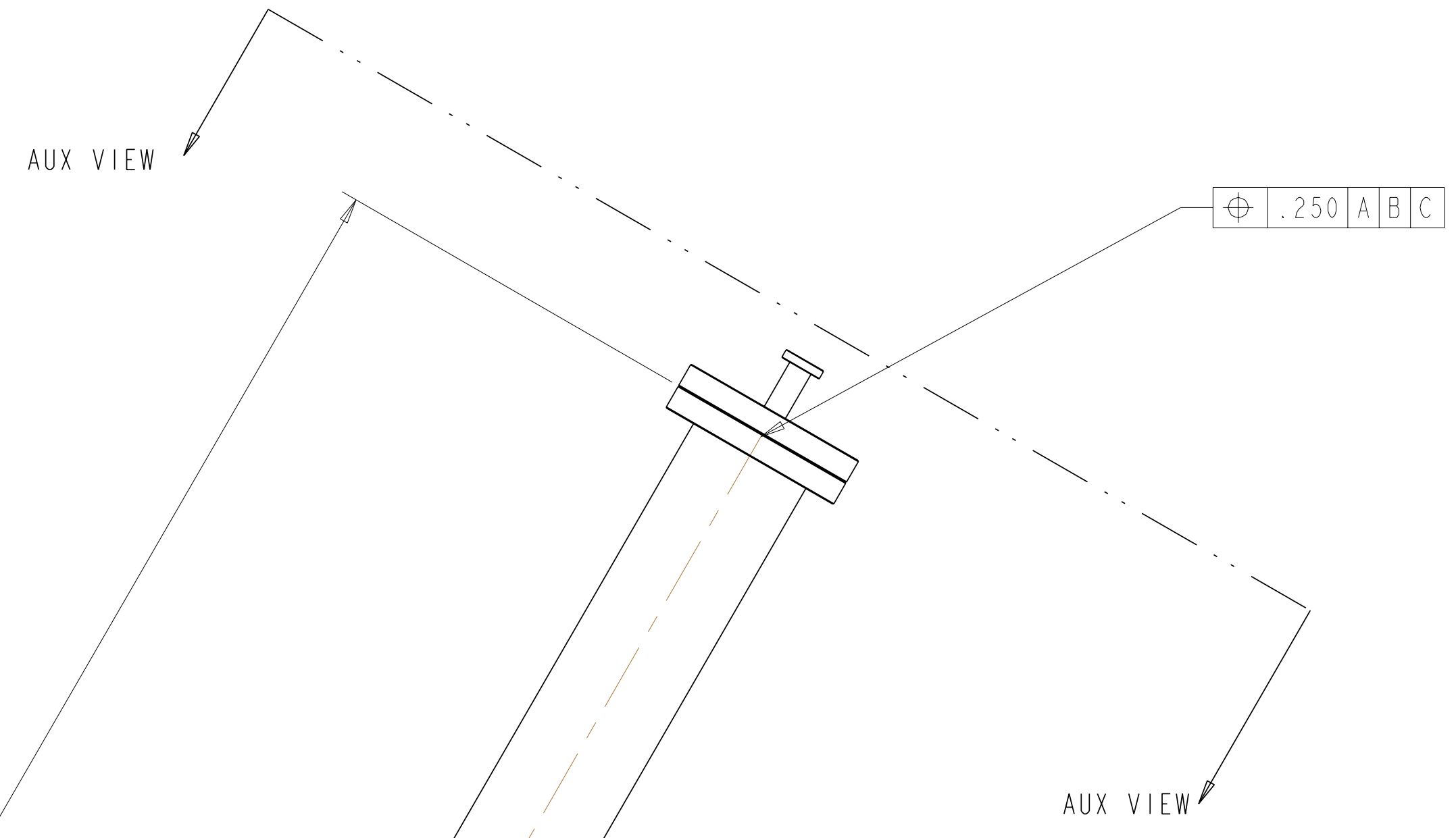

FOR NOTES AND PARTS LIST SEE SHEET 1

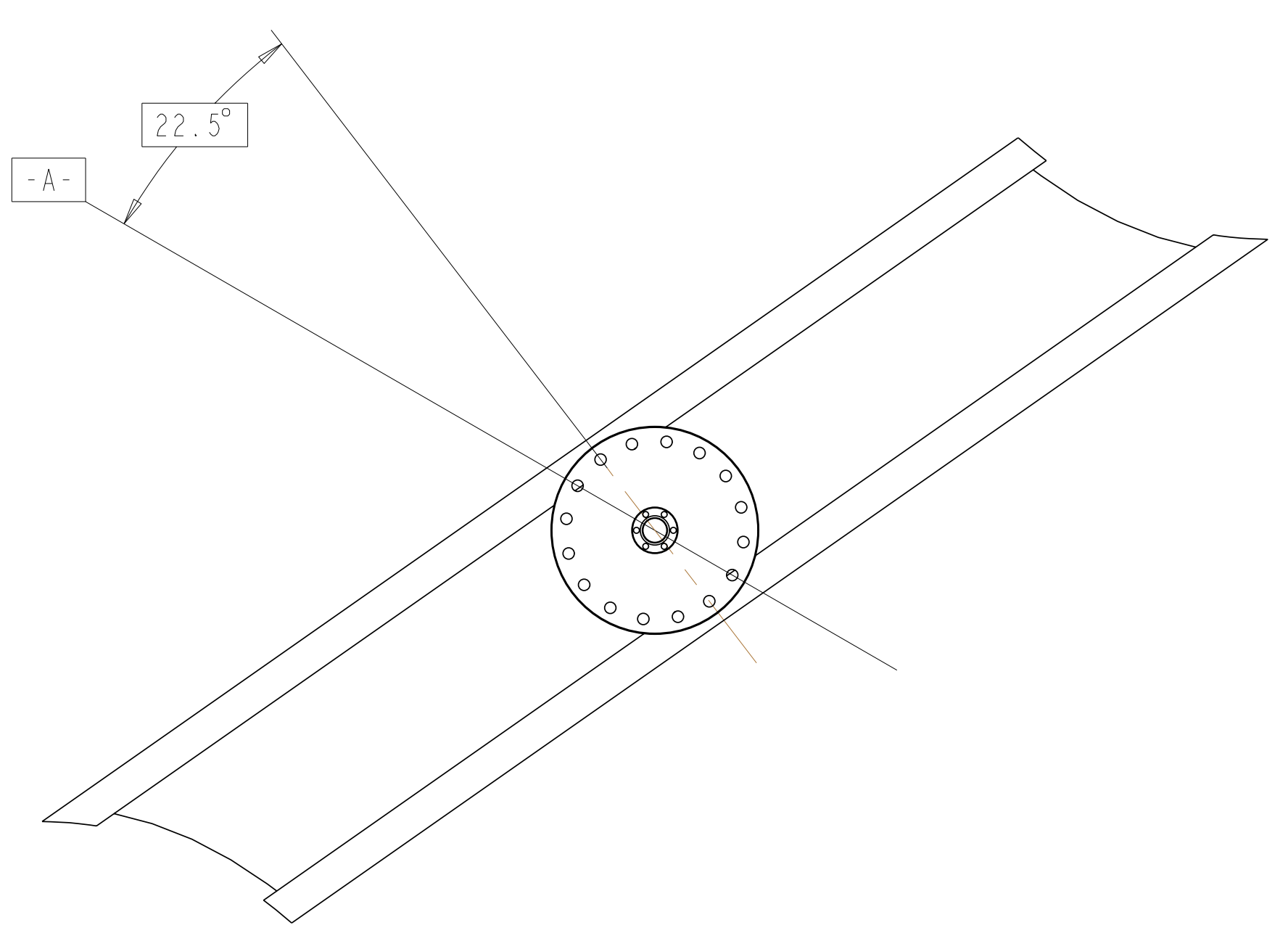

99.36

⊕ .250 A B C

⌒ .375 A B C

DATUM A = PLANE THRU "XY"  
 DATUM B = PLANE THRU "XZ"  
 DATUM C = PLANE THRU "YZ"

(60°)

SCALE 0.250

-B-

**RELEASED FOR  
 FABRICATION / INSTALLATION**  
 PPPL Drafting:

UT-BATTELLE		Oak Ridge National Laboratory managed for the DEPARTMENT OF ENERGY under U.S. GOVERNMENT contract DE-AC05-00OR22725 UT-BATTELLE, LLC, Oak Ridge, Tennessee					
PROJECT NAME							
NATIONAL COMPACT STELLARATOR EXPERIMENT							
VACUUM VESSEL SPACER WELDMENT							
VERSION NO.	PLANT	BLDG	FL	SHT OF	TYPE	CLASS	
1	X-10	5700	3	2 2	S	U	
RELEASE LEVEL Fabrication		SEI21-014					
						REV I	

SEI21-014

A