

ISOMETRIC VIEW

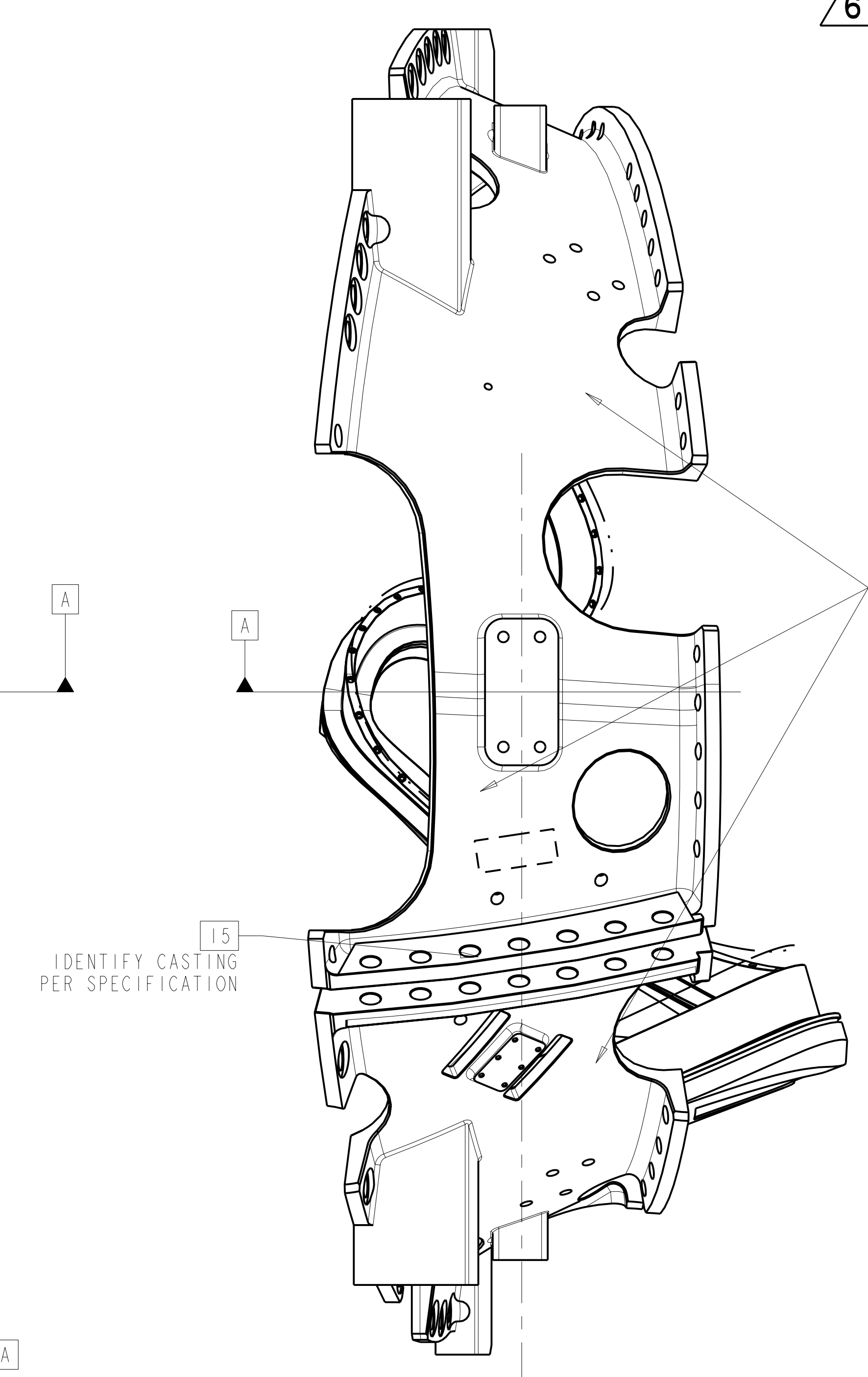
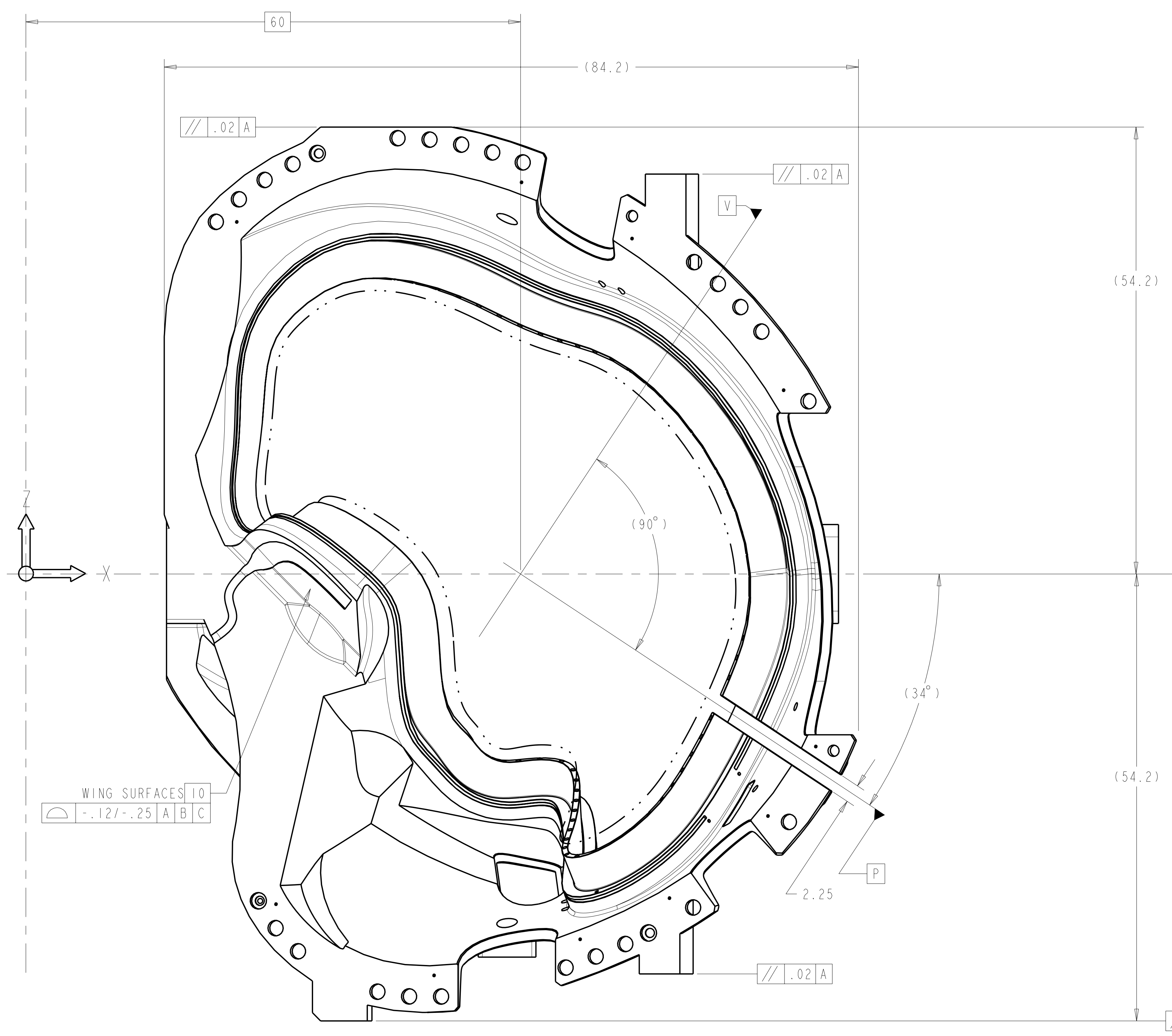

- NOTES:
- DRAWING PREPARED IN ACCORDANCE WITH ASME Y14.8M-1996.
  - INTERPRET DIMENSIONS AND TOLERANCES PER ANSI Y14.5M-1994.
  - DIMENSIONS ARE IN INCHES.
  - DRAWING DEPICTS FINAL MACHINED STATE OF PART DEFINED BY PRO/ENGINEER FILE SEI41-115.PRT.
  - UNLESS OTHERWISE SPECIFIED, DIMENSIONS ARE RELATED TO DATUM A- (PRIMARY X-Y PLANE, TOP) DATUM B- (SECONDARY Y-Z PLANE, SIDE) DATUM C- (TERTIARY X-Z PLANE, FRONT)
  - DIMENSIONS APPLY AT TEMPERATURE OF 20-30°C (68-86°F).
  - DIMENSIONS AND TOLERANCES EXCLUDE PROCESS MATERIAL ALLOWANCES WHICH MAY ADD MASS.
  - APPROXIMATE WEIGHT = 4368 LBS. WEIGHT OF FINISHED PART NOT TO EXCEED 6000 LBS.
  - UNLESS OTHERWISE SPECIFIED, AS-CAST SURFACE PROFILE TOLERANCE = +/- .25 - INCH, WITH EXEMPTION FOR INTERSECTING SURFACES WHERE FILLETS ARE EXPECTED. MIN FILLET AND CORNER RADIUS = 0.5 +/- 0.1-IN.
  - DESIGNATED SURFACE REGIONS HAVE PROFILE TOLERANCE OF -0.12 TO -0.25-IN, WHERE POSITIVE INDICATES OUTWARD SURFACE NORMAL DIRECTION (ADDS MATERIAL).
  - MIN THICKNESS PER CAD GEOMETRY, TOLERANCE = +0.25-IN / -0.0-IN.
  - PARTING LINE EDGES, FLASH, GATES, RUNNER, AND RISER EXTENSIONS 0.25-IN MAX
  - UNLESS OTHERWISE SPECIFIED, MACHINED SURFACE PROFILE TOLERANCE = +/- 0.02-IN.
  - BACK SPOTFACE ALL THRU HOLES MINIMUM TO CLEAN UP.
  - SEE LATEST REVISION OF SPECIFICATION NCSX-CSPEC-141-03 FOR ADDITIONAL REQUIREMENTS.
  - GRIND TEE BASE AS REQUIRED TO ACHIEVE CLEARANCE DEFINED BY TEMPLATE SHOWN IN THE SPECIFICATION.

**Rev 9-a: RFD-14-023R1** stated that the tapped and drilled holes in the VV support bosses (pads) as shown in the drawings should be provided to the maximum extent possible, given the undersize condition of some of the pads. To help in this regard, MTM was requested to offset the hole pattern relative to the cast pads as necessary to permit more (or all) of the tapped holes in the pads to be provided. NCSX will weld mounting studs as needed. **This is considered a relatively minor change and a drawing change will not be required.** (See RFD-14-023R1 for details)

**Rev 9-b: NCSX Project rapid response dated 10/4/2006 (Sutton to Horton of EIO)** authorized the option to bore the counterbore relief for Hole 11 on the D flanges of the B1 and B2 castings. RFD-14-025 extended that authorization to the remaining B3 through B6 castings. **This is considered a relatively minor change and a drawing change will not be required.** (See RFD-14-025 for details)

**RELEASED FOR FABRICATION / INSTALLATION**  
PPPL Drafting:

REV	DESCRIPTION	BY	DATE	CHK	DEPT	DATE	PE	REQ	DATE	ORNL	DOE	DATE
9	REVISED PART AND DRAWING PER ECN 5145	GLL	07/08/MJC									
8	REVISED PART AND DRAWING PER ECN 5128	GLL	06/06/MJC									
7	REVISED WING POCKET PROFILE TOL PER ECN 5189	DEW	03/06/MJC									
6	REVISE PART AND DRAWING PER ECN 5059 AND 5064	GLL	01/06/MJC									
5	REVISE PART AND DRAWING PER ECN 5009	GLL	07-05/MJC									
4	REVISED PART AND DRAWING PER ECN 4994	GLL	06-05/MJC									
3	REVISED PART AND DRAWING PER ECN 4965	GLL	03-05/MJC									
2	REVISED PART AND DRAWING PER ECN 4944	GLL	1/05/MJC									
1	REMOVED SPHERICAL SEATS, REVISED LEAD BLOCK/COOLING PER ECN-4903	GLL	09/04/MJC									

**ECN-5185** revised clearance requirements for all flange back spot faces and for all remaining winding forms (C-6, B-3 through B-6, and A-4 through A-6) => shall be a cylinder 3" from the spot face surface and the blend-in radius at the upper extent of this machine area shall be 1/4".  
For the Type B MCWF, a clearance dimension of 9.00" ± 0.05" is defined between the center of the lead block mounting pad and the support post. Clearance envelop height extends through the post as required (see sketch on ECN-5185).1

NO REPRESENTATION OR WARRANTY, EXPRESSED OR IMPLIED, IS MADE AS TO THE ACCURACY, COMPLETENESS OR USEFULNESS OF THE INFORMATION OR STATEMENTS CONTAINED IN THESE DRAWINGS, OR THAT THE USE OR DISCLOSURE OF ANY INFORMATION, APPARATUS, METHOD OR PROCESS DISCLOSED IN THESE DRAWINGS MAY NOT INFRINGE PRIVATE RIGHTS OF OTHERS. NO LIABILITY IS ASSUMED WITH RESPECT TO THE USE OF, OR FOR DAMAGES RESULTING FROM THE USE OF, ANY INFORMATION, APPARATUS, METHOD OR PROCESS DISCLOSED IN THESE DRAWINGS. DRAWINGS MADE AVAILABLE FOR INFORMATION TO BIDDER ARE NOT TO BE USED FOR OTHER PURPOSES, AND ARE TO BE RETURNED UPON REQUEST OF THE FORWARDING CONTRACTOR.

**P** THIS DRAWING PRODUCED ON PRO-ENGINEER

REV	DESCRIPTION	BY	DATE	CHK	DEPT	DATE	PE	REQ	DATE	ORNL	DOE	DATE
9	REVISED PART AND DRAWING PER ECN 5145	GLL	07/08/MJC									
8	REVISED PART AND DRAWING PER ECN 5128	GLL	06/06/MJC									
7	REVISED WING POCKET PROFILE TOL PER ECN 5189	DEW	03/06/MJC									
6	REVISE PART AND DRAWING PER ECN 5059 AND 5064	GLL	01/06/MJC									
5	REVISE PART AND DRAWING PER ECN 5009	GLL	07-05/MJC									
4	REVISED PART AND DRAWING PER ECN 4994	GLL	06-05/MJC									
3	REVISED PART AND DRAWING PER ECN 4965	GLL	03-05/MJC									
2	REVISED PART AND DRAWING PER ECN 4944	GLL	1/05/MJC									
1	REMOVED SPHERICAL SEATS, REVISED LEAD BLOCK/COOLING PER ECN-4903	GLL	09/04/MJC									

SCALE	NOTED	DES	T BROWN	6-30-04
TOLERANCES UNLESS OTHERWISE SPECIFIED		DRW	PAUL MILLER	6-30-04
FRACTIONS		CHK	M COLE	6-30-04
XX DECIMALS ±.01		SECT :		
XXX DECIMALS ±.005		DEPT :		
ANGLES ±0°15'		PE	D WILLIAMSON	6/25/04
BREAK SHARP EDGES OR MAX FINISH .125 UNLESS OTHERWISE SPECIFIED		CR :		
		PJ :		
		RD :		
		PPPL DRFT	J SIEGEL	6/25/04
		VERSION NO.	2	
		PLANT	X-10	
		BLDG	5700	
		FL	3	
		SHT	12	
		OF	12	
		TYPE	S	
		CLASS	U	
		RELEASE LEVEL	Fabrication	
		SEI41-115		
		REV	9	

SEI41-115

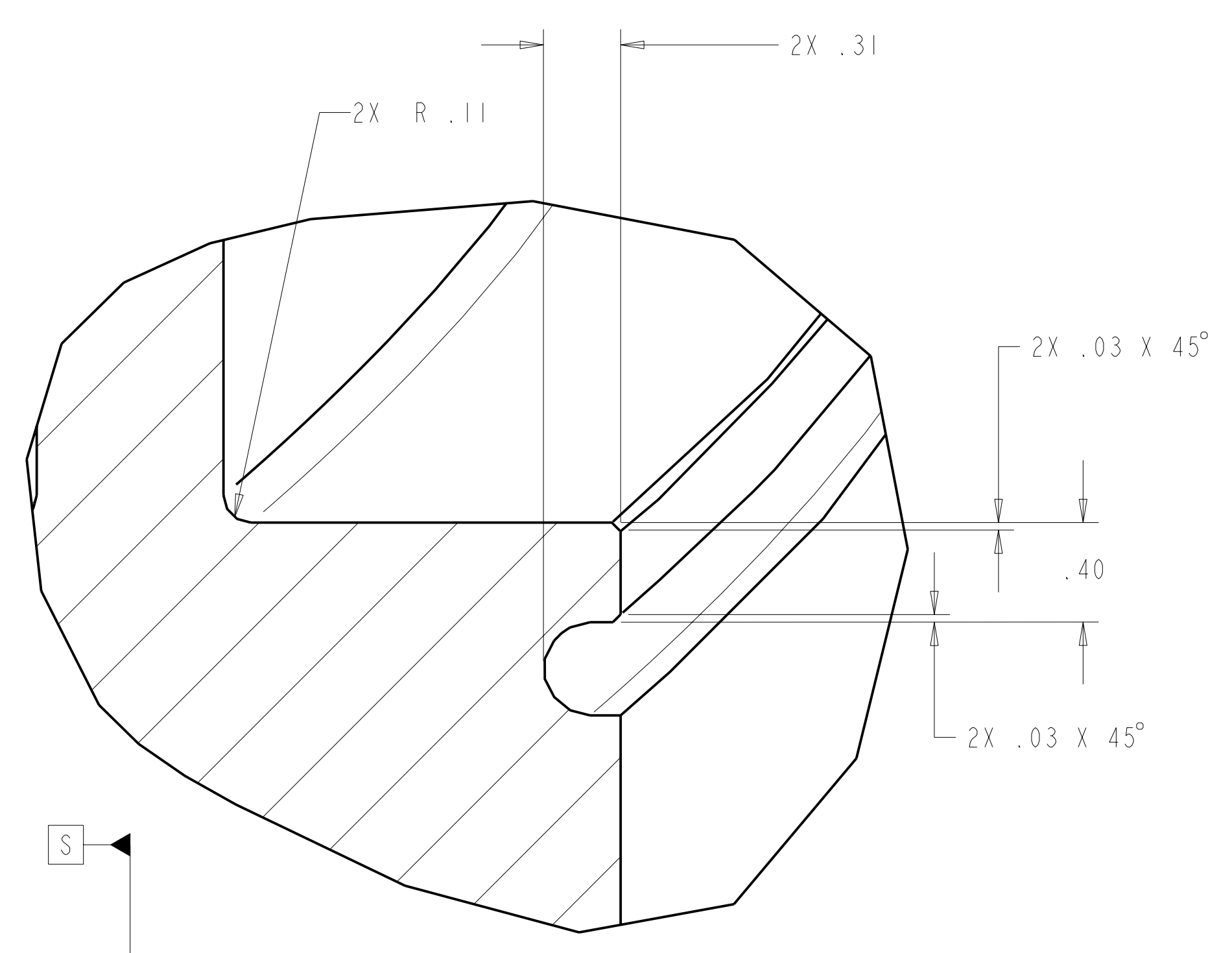

DETAIL B  
SCALE 2.00

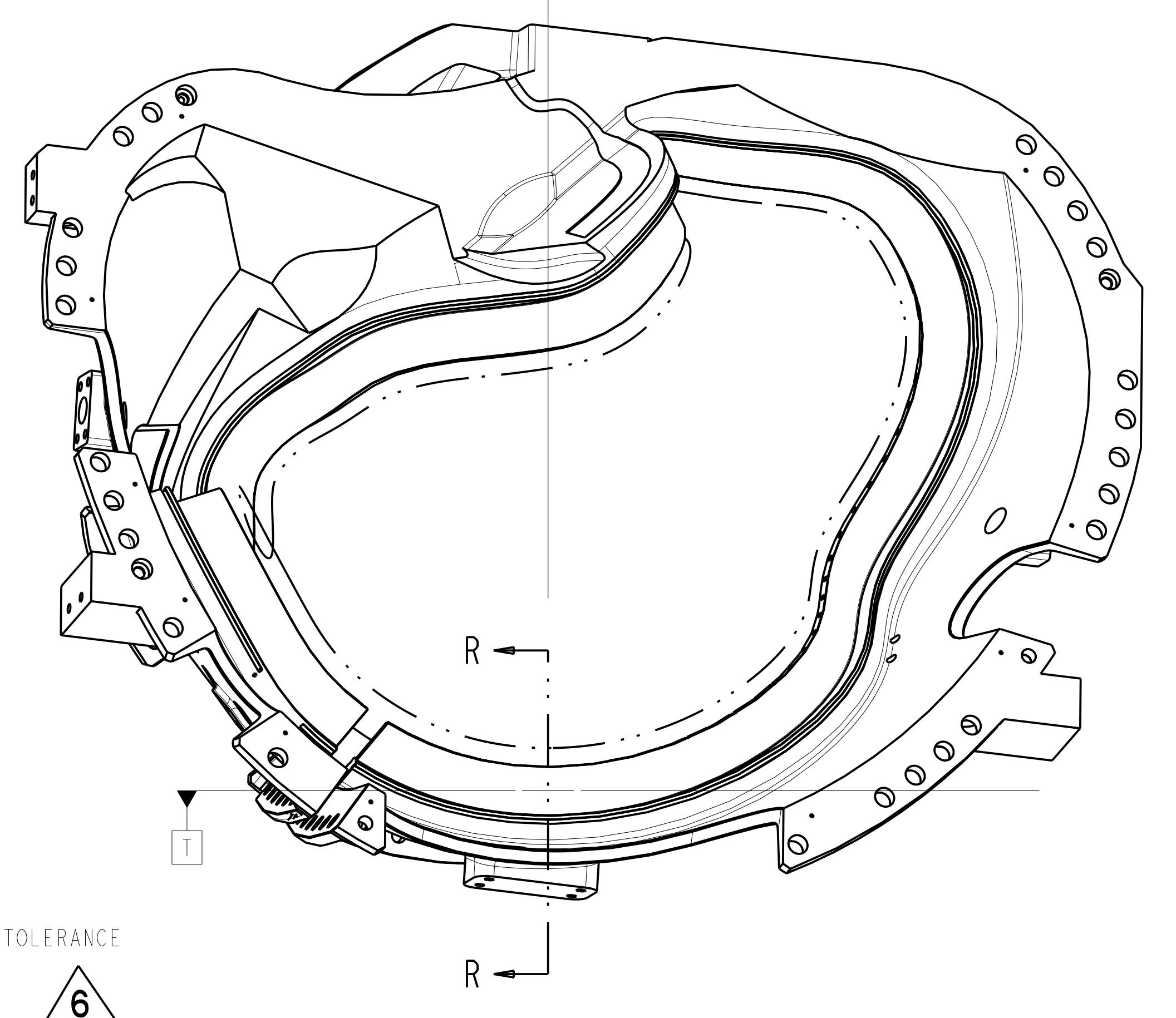
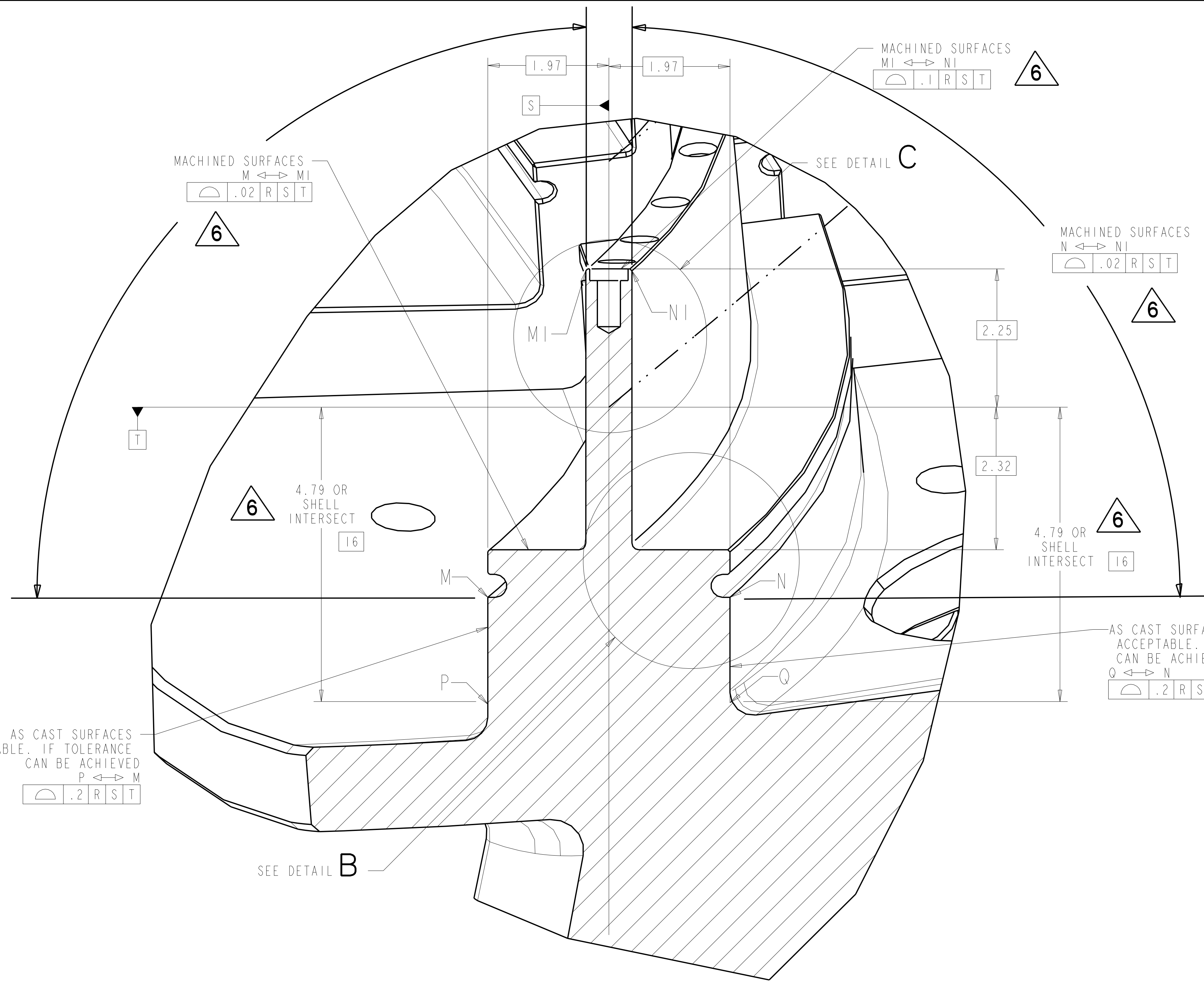

SECTION R-R  
SCALE 0.250

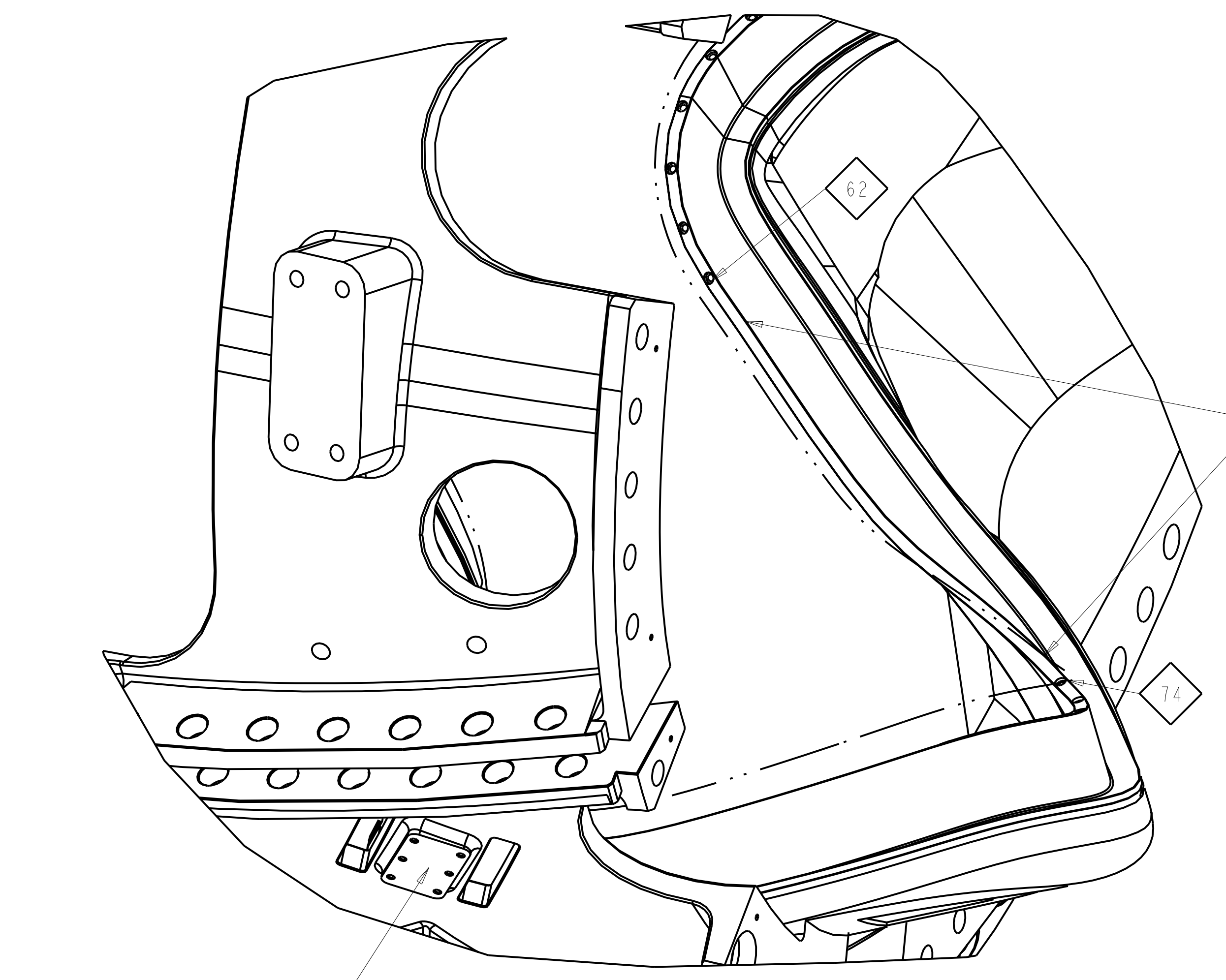

TEE HOLE NUMBERS START AT LEADS AND INCREASE TOWARD POLOIDAL BREAK

TEE HOLES OMITTED  
SCALE 0.20

OMIT TAPPED HOLE (DETAIL C) FOR HOLES NO. 63 THRU 73 KEEP  $\square$  .625  $\nabla$  .188  
REMOVE  $\varnothing$  .625 COUNTERBORE AND ADD MARK WHERE FORMER HOLE AXIS INTERSECTS SURFACE AT TOP OF TEE.

DETAIL A  
SCALE 1.00  
TYPICAL FOR ALL POINTS ALONG WINDING CENTER

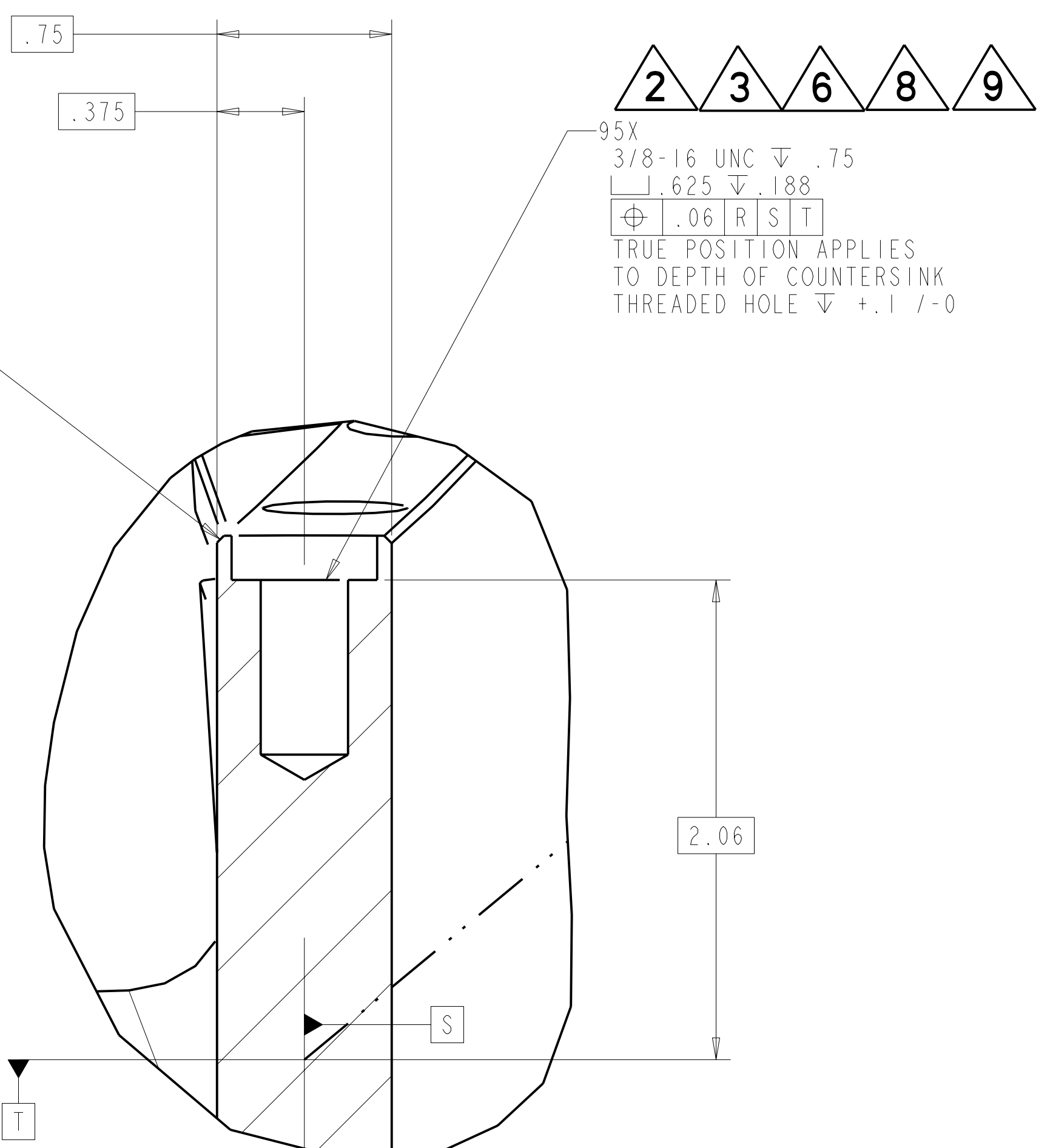

DETAIL C  
SCALE 2.00

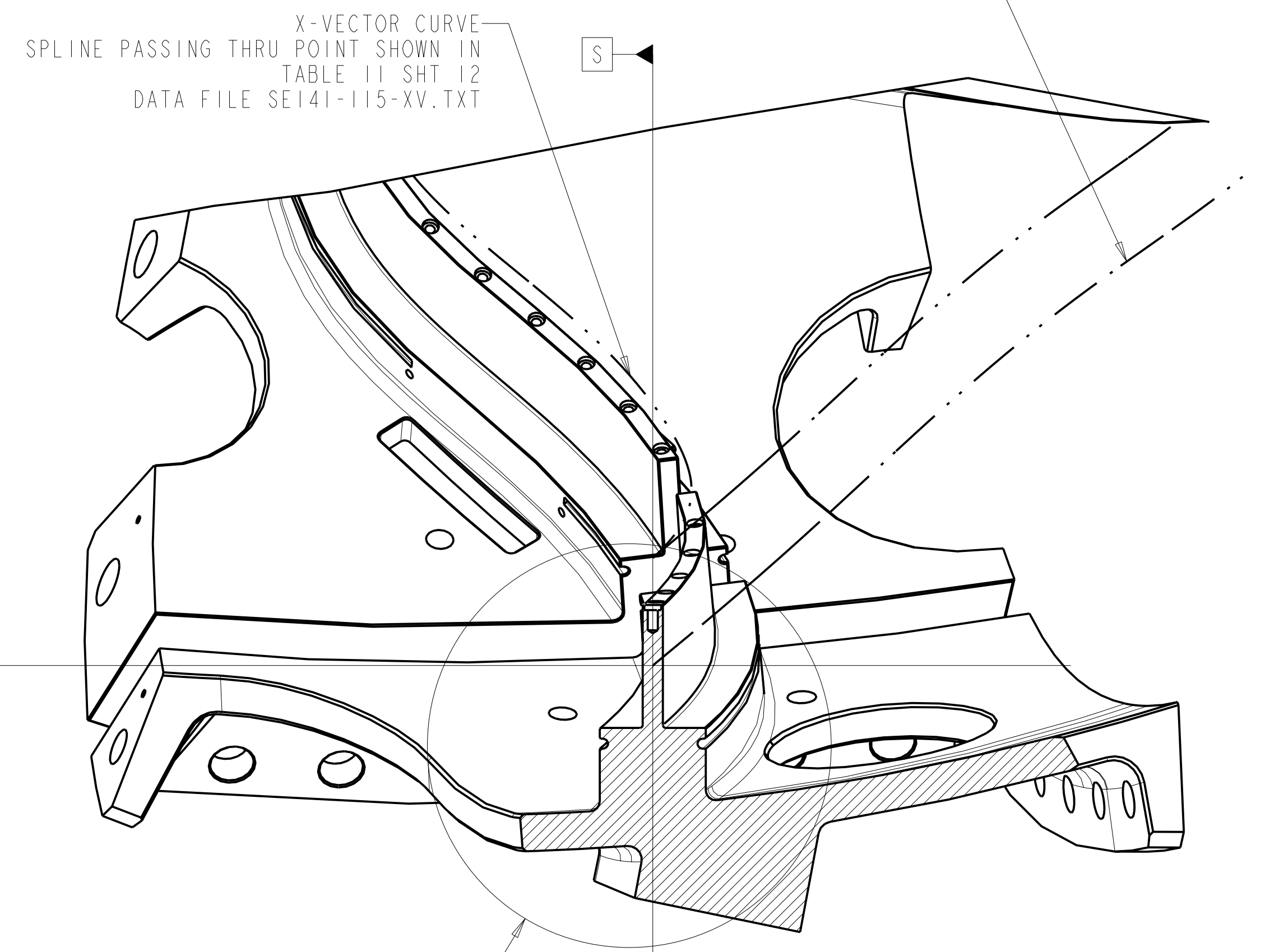

SEE DETAIL A

DATUM R = PLANE NORMAL TO WINDING CENTER  
DATUM S = PLANE PASSING THRU WINDING CENTER AND X VECTOR AT DATUM R  
DATUM T = PLANE PASSING THRU WINDING CENTER ORTHOGONAL TO DATUM S

**RELEASED FOR FABRICATION / INSTALLATION**  
PPPL Drafting:

Oak Ridge National Laboratory managed for the DEPARTMENT OF ENERGY under U.S. GOVERNMENT contract DE-AC05-00OR22725 UT-BATTELLE, LLC. Oak Ridge, Tennessee PROJECT NAME:										
<b>UT-BATTELLE</b> NATIONAL COMPACT STELLARATOR EXPERIMENT										
PRODUCTION WINDING FORM TYPE-B										
VERSION NO. 2	PLANT X-10	BLDG 5700	FL 3	SHT OF 2	TYPE 12	CLASS S	RELEASE LEVEL Fabrication			SEI41-115 REV 9

FOR NOTES AND PARTS LIST SEE SHEET 1

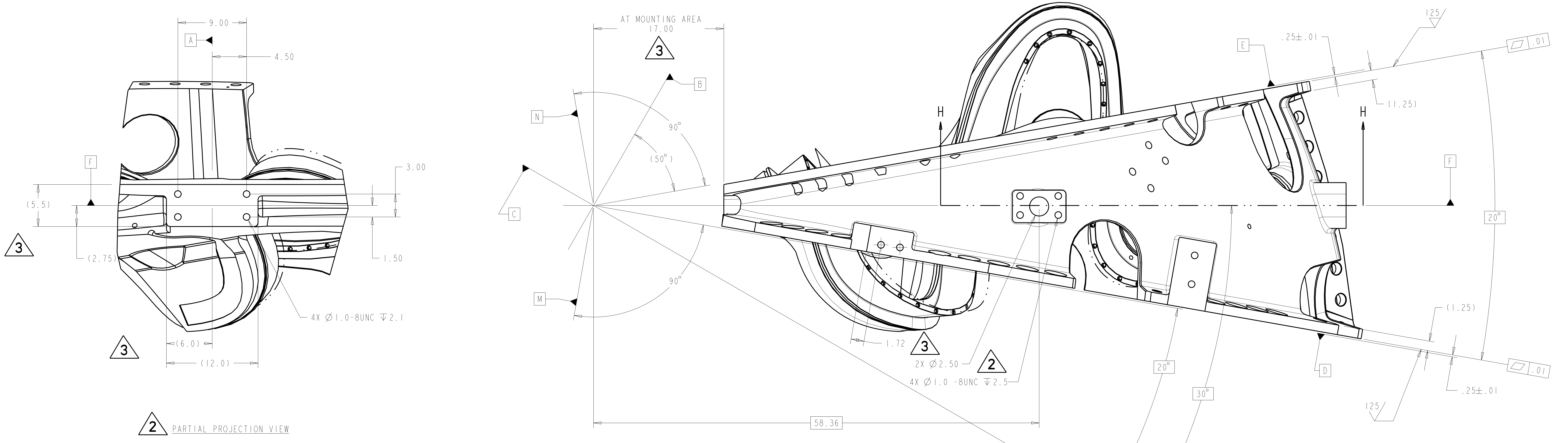

TOP VIEW  
SCALE 0.19

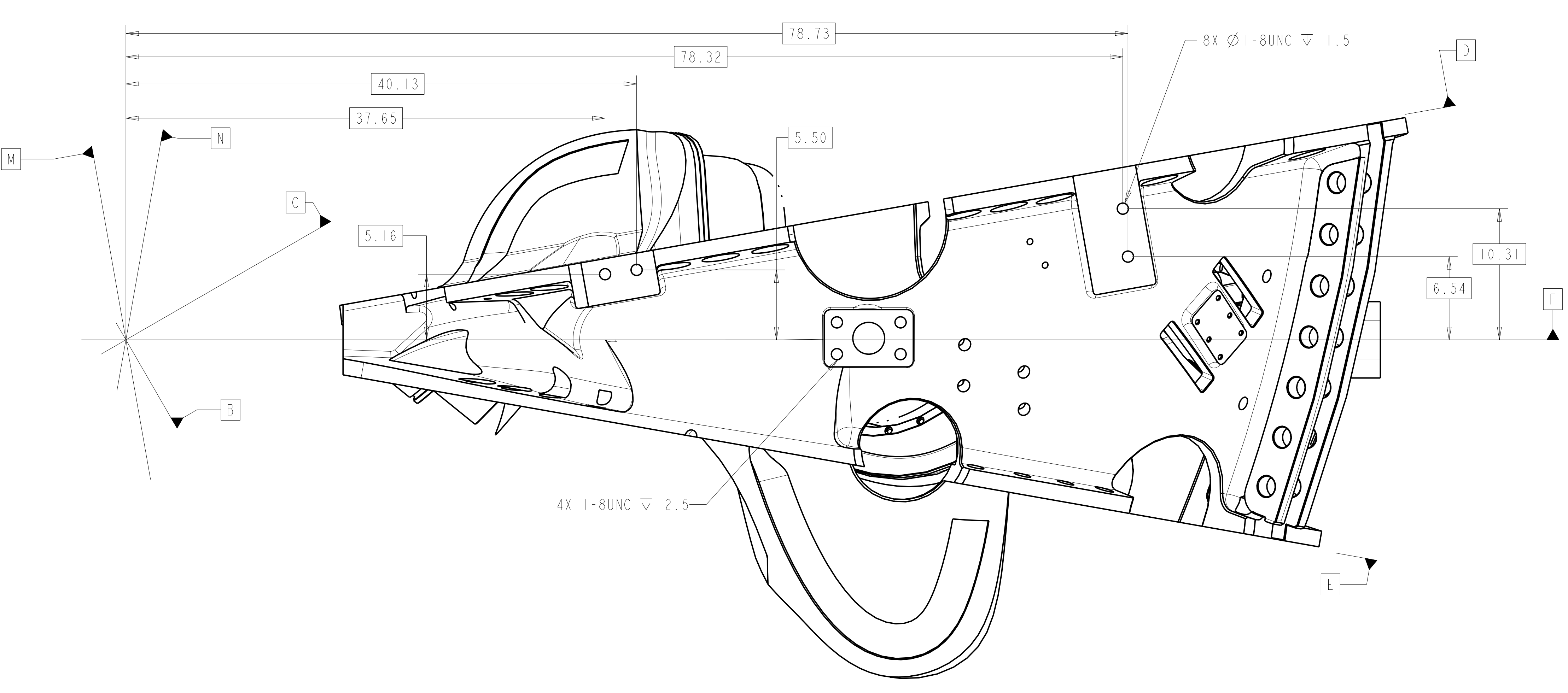

BOTTOM VIEW  
SCALE 0.19

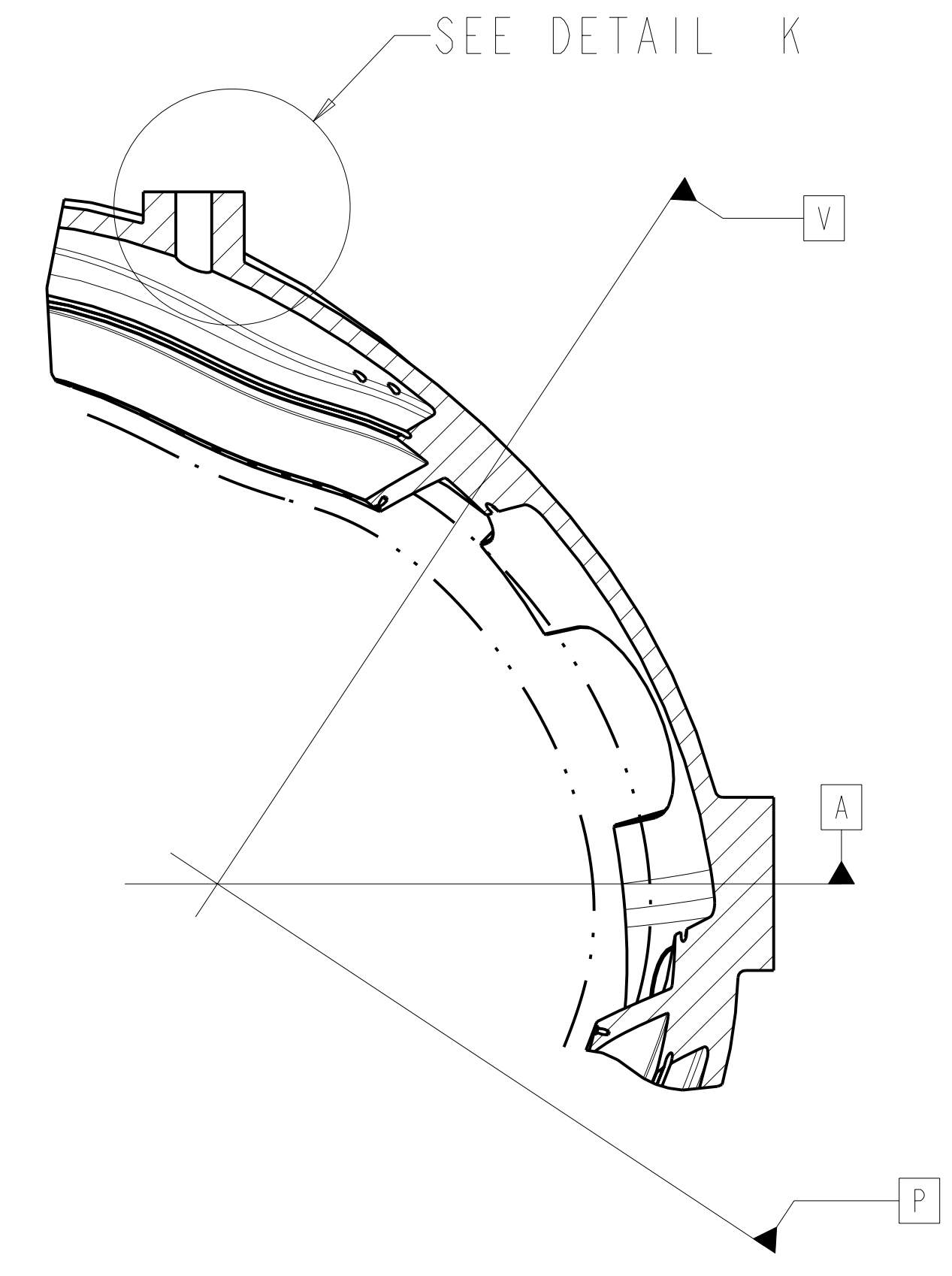

SECTION H-H  
VESSEL VERTICAL SUPPORT  
SCALE 0.10

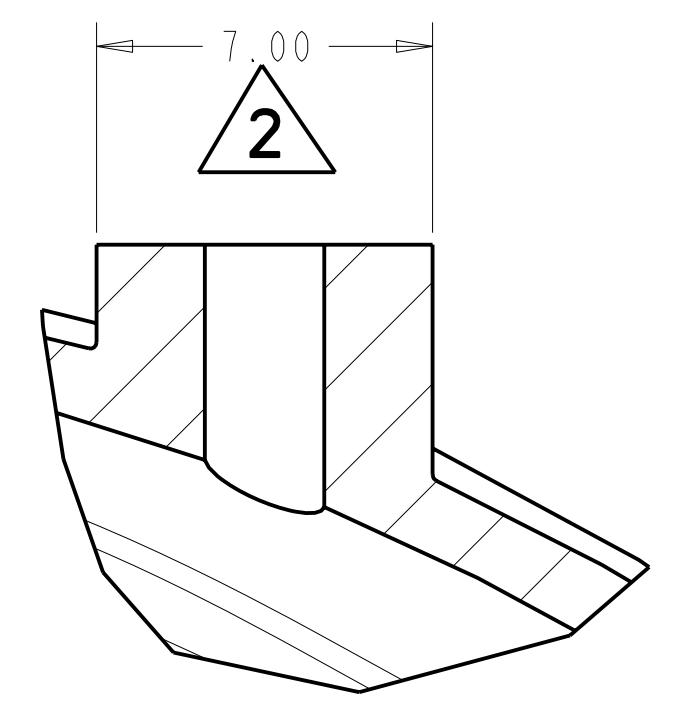

DETAIL K  
TYPICAL 2 PLACES  
SCALE 0.25

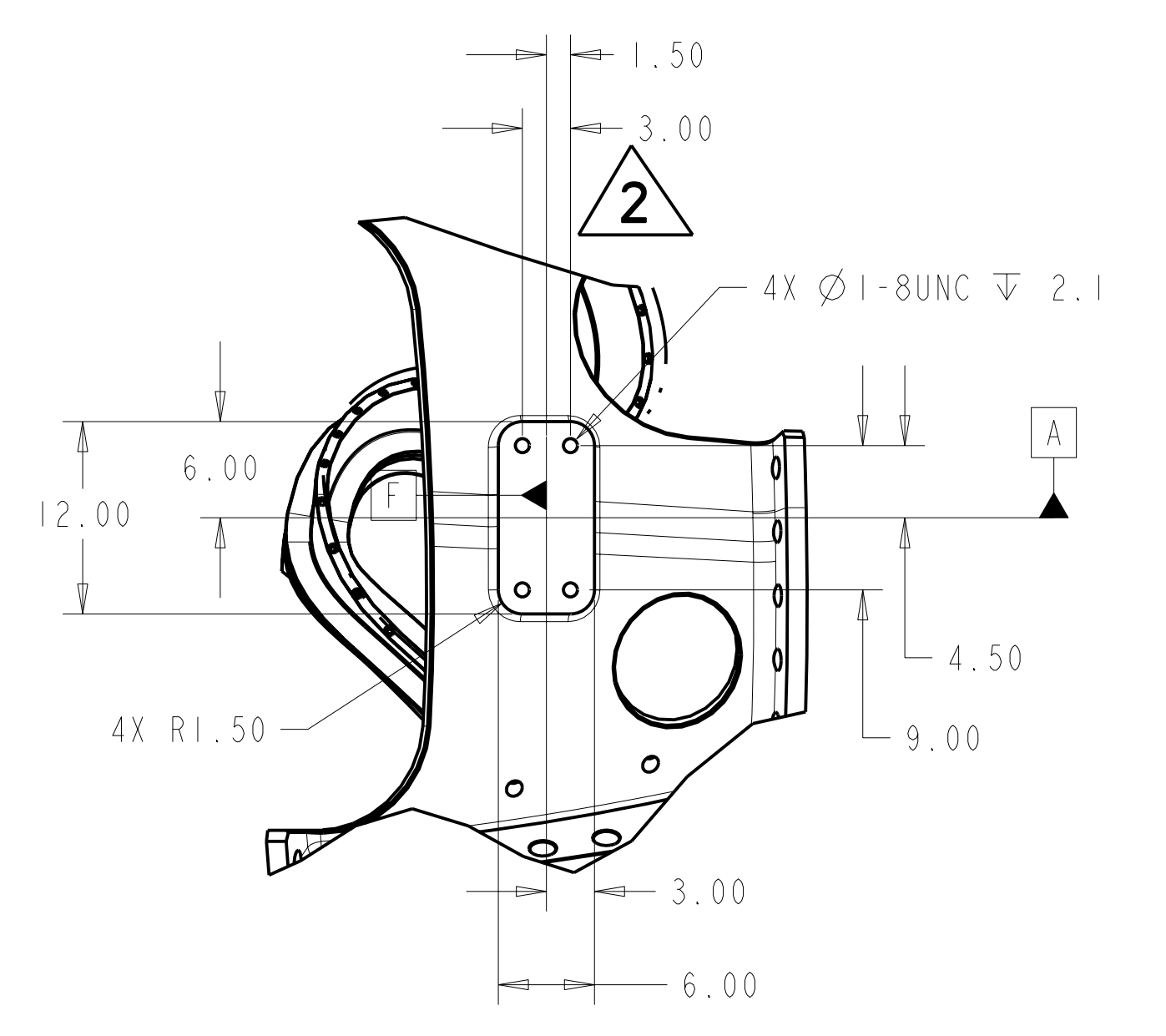

PROJECTION FROM SECTION H-H

**RELEASED FOR  
FABRICATION / INSTALLATION**  
PPPL Drafting:

Oak Ridge National Laboratory managed for the DEPARTMENT OF ENERGY under U.S. GOVERNMENT contract DE-AC05-00OR22725 UT-BATTELLE, LLC. Oak Ridge, Tennessee									
<b>UT-BATTELLE</b>									
PROJECT NAME <b>NATIONAL COMPACT STELLARATOR EXPERIMENT</b>									
PRODUCTION WINDING FORM TYPE-B									
VERSION NO. 2	PLANT X-10	BLDG 5700	FL 3	SHT OF 3	TYPE 12	CLASS S			
RELEASE LEVEL Fabrication		SE141-115					REV 9		

SE141-115

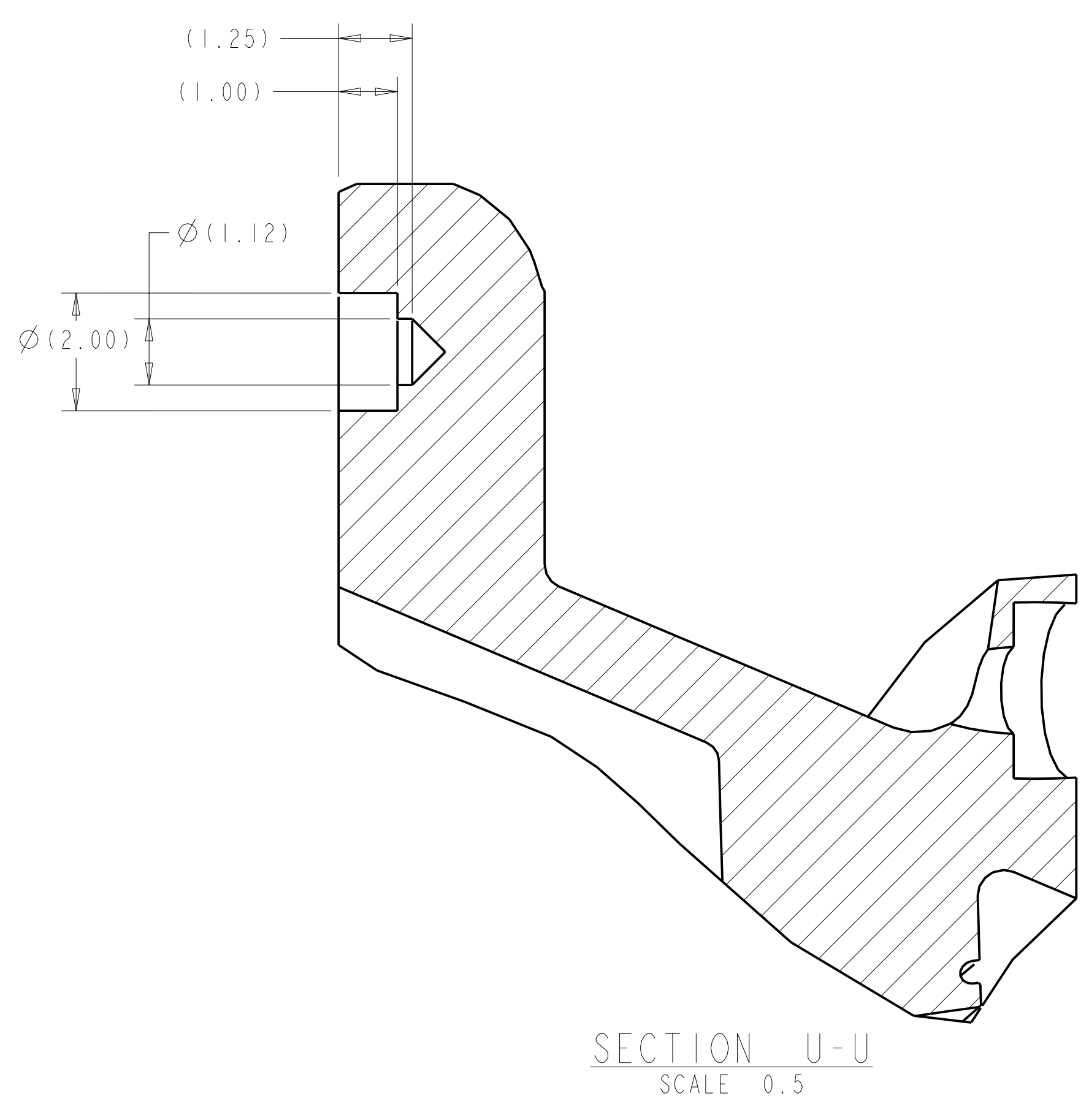
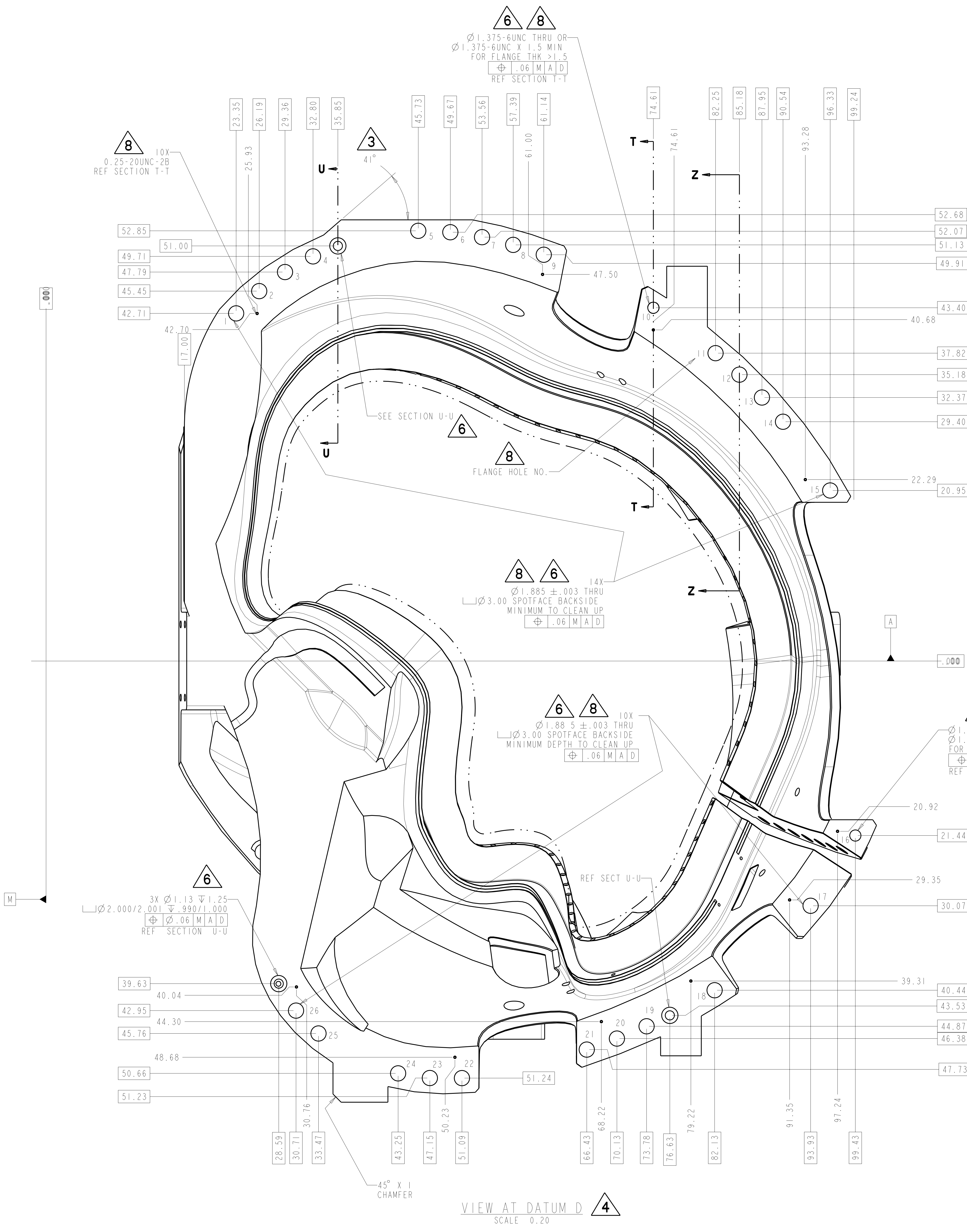

SECTION U-U SCALE 0.5

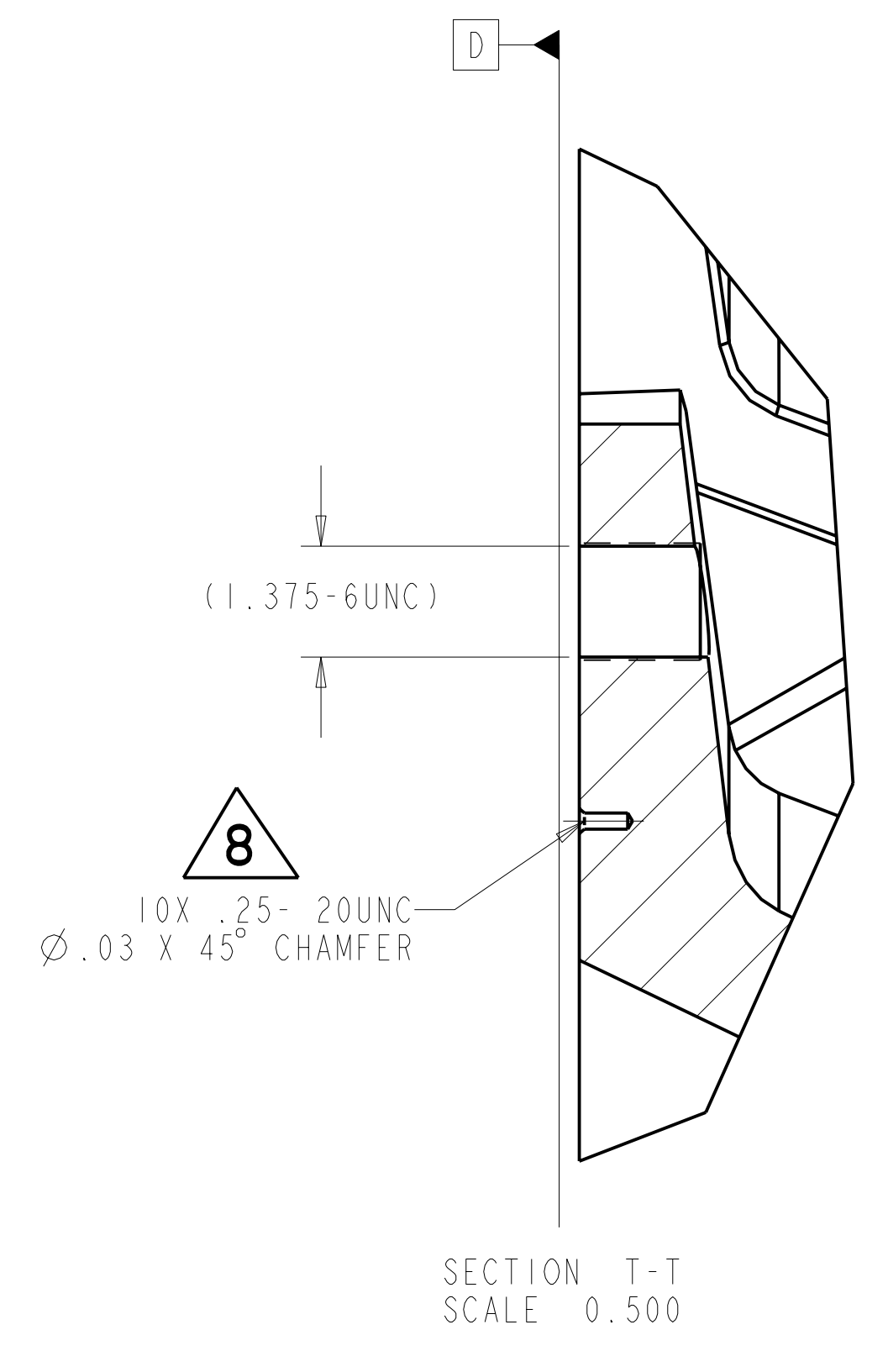

SECTION T-T SCALE 0.500

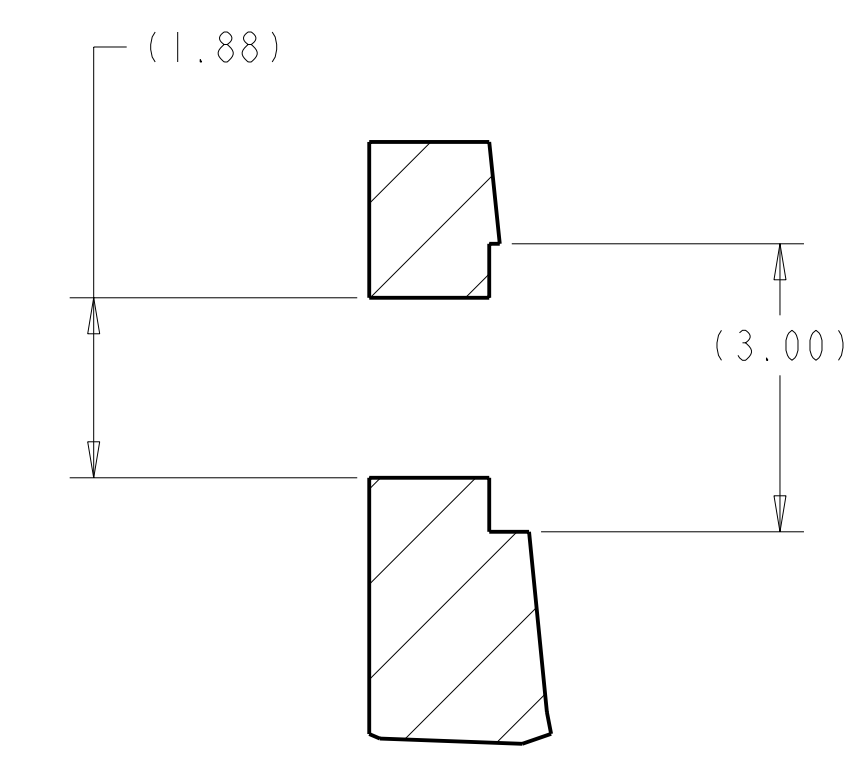

SECTION Z-Z SCALE 0.50

**RELEASED FOR  
FABRICATION / INSTALLATION**

PPPL Drafting:

VIEW AT DATUM D  
SCALE 0.20

Oak Ridge National Laboratory managed for the DEPARTMENT OF ENERGY under U.S. GOVERNMENT contract DE-AC05-00OR22725 UT-BATTELLE, LLC. Oak Ridge, Tennessee									
<b>UT-BATTELLE</b>									
NATIONAL COMPACT STELLARATOR EXPERIMENT									
PRODUCTION WINDING FORM TYPE-B									
VERSION NO. 2	PLANT X-10	BLDG 5700	FL 3	SHT OF 4	TYPE 12	CLASS S	REV U		
RELEASE LEVEL Fabrication		SE141-115					REV 9		

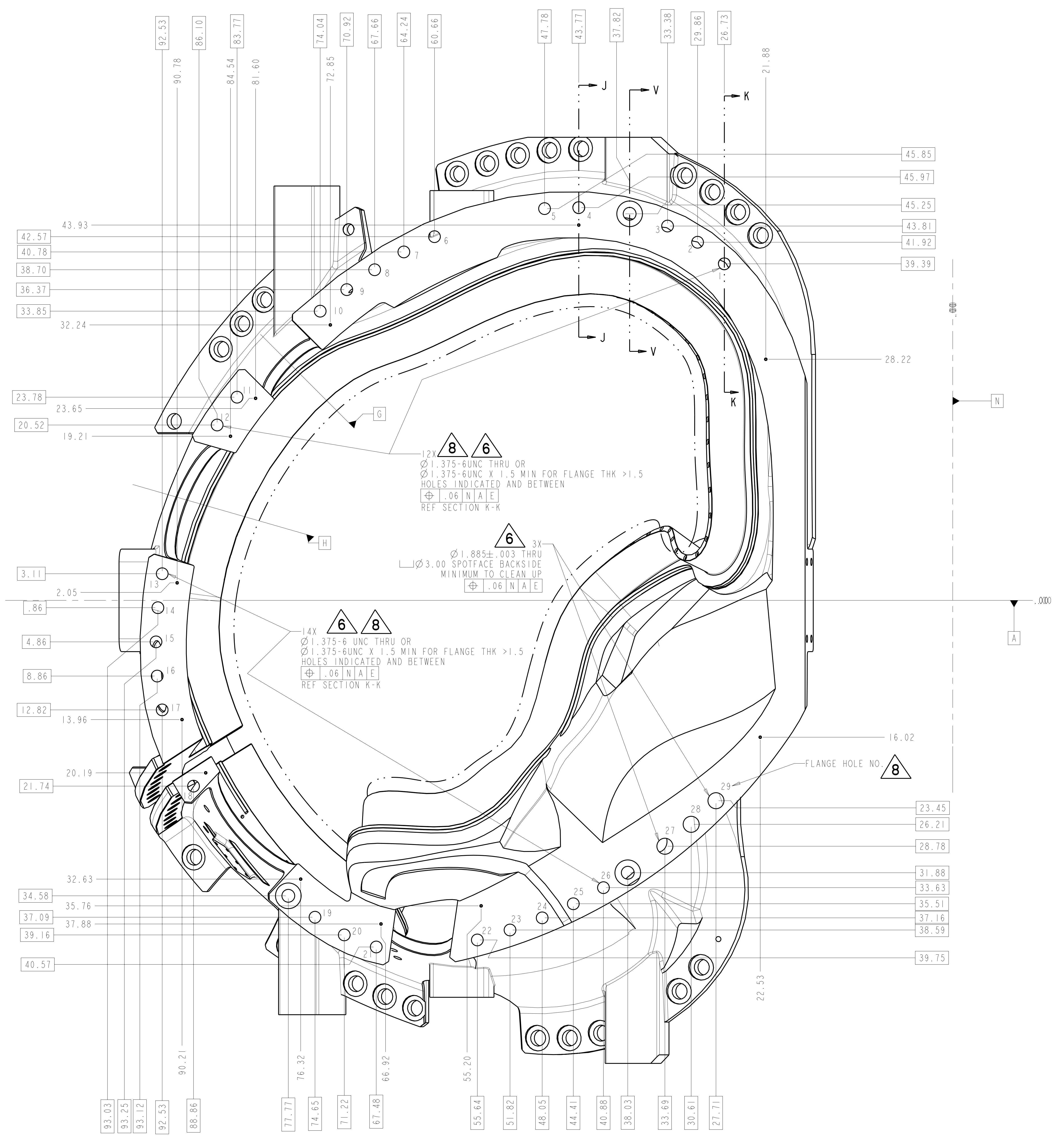
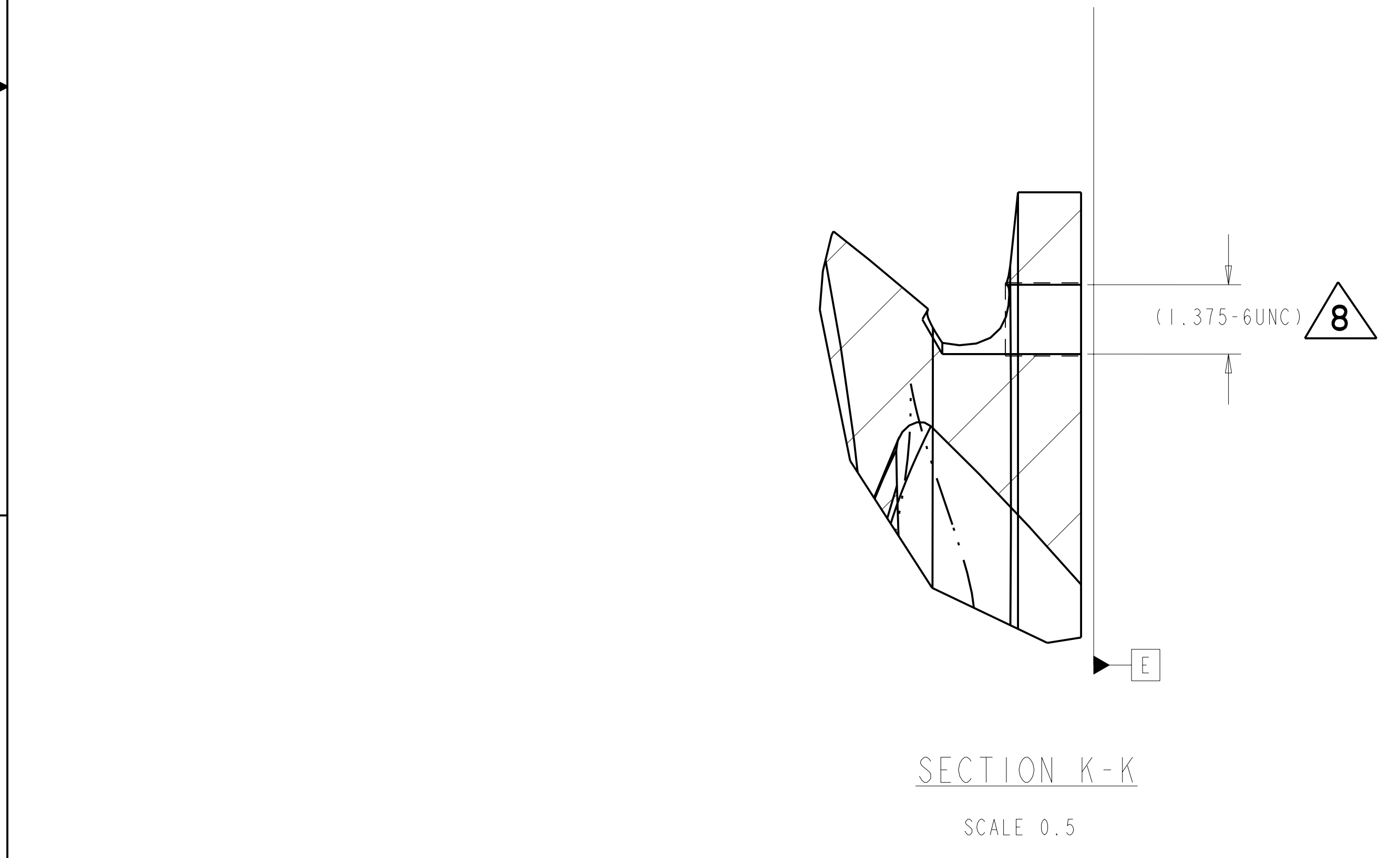
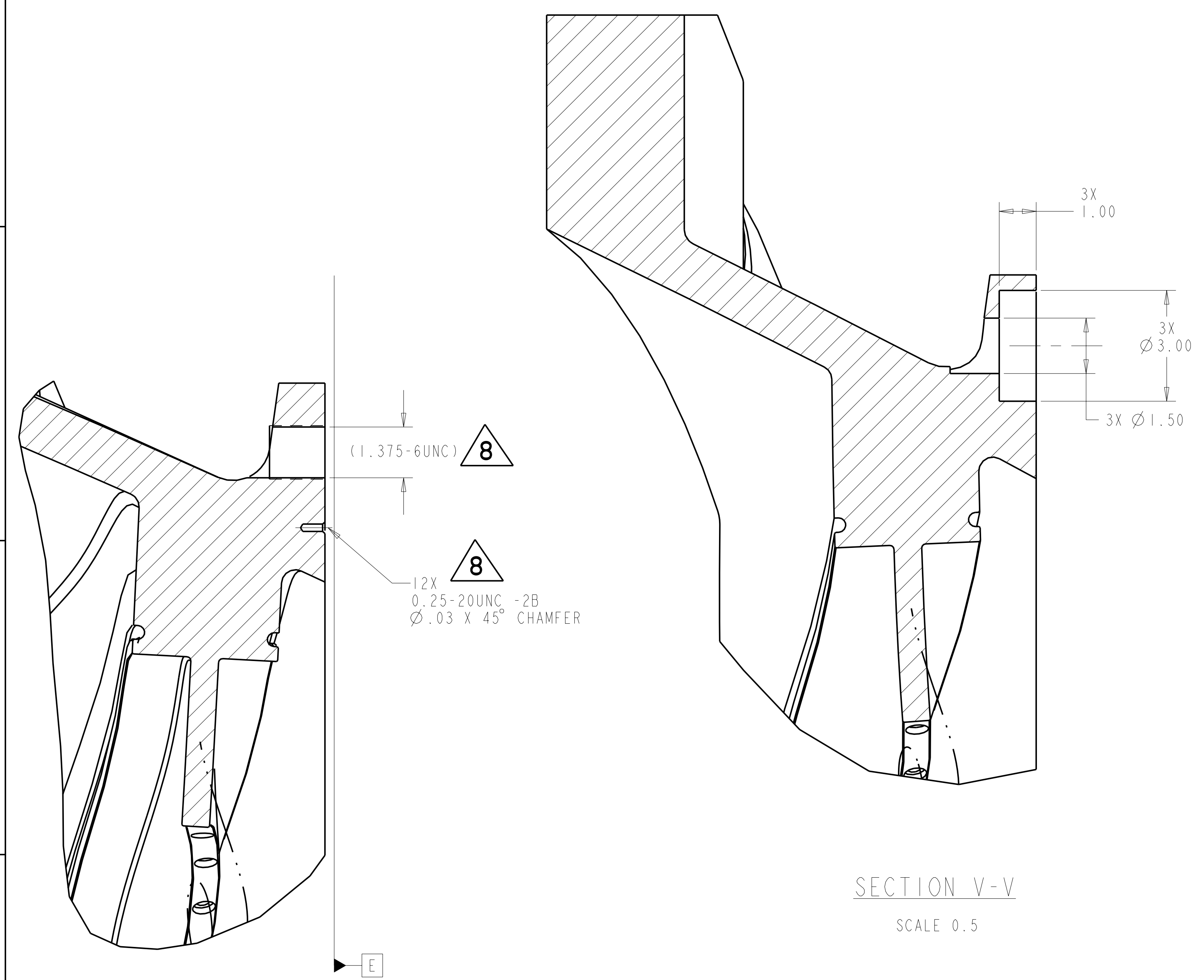

**RELEASED FOR  
FABRICATION / INSTALLATION**

PPPL Drafting:

Oak Ridge National Laboratory managed for the DEPARTMENT OF ENERGY under U.S. GOVERNMENT contract DE-AC05-00OR22725 UT-BATTELLE, LLC. Oak Ridge, Tennessee PROJECT NAME:									
<b>UT-BATTELLE</b> <b>NATIONAL COMPACT STELLARATOR EXPERIMENT</b>									
PRODUCTION WINDING FORM TYPE-B									
VERSION NO.	PLANT	BLDG	FL	SHT	OF	TYPE	CLASS		
2	X-10	5700	3	5	12	S	U		
RELEASE LEVEL		SE141-115						REV	
Fabrication								9	

FOR NOTES AND PARTS LIST SEE SHEET 1

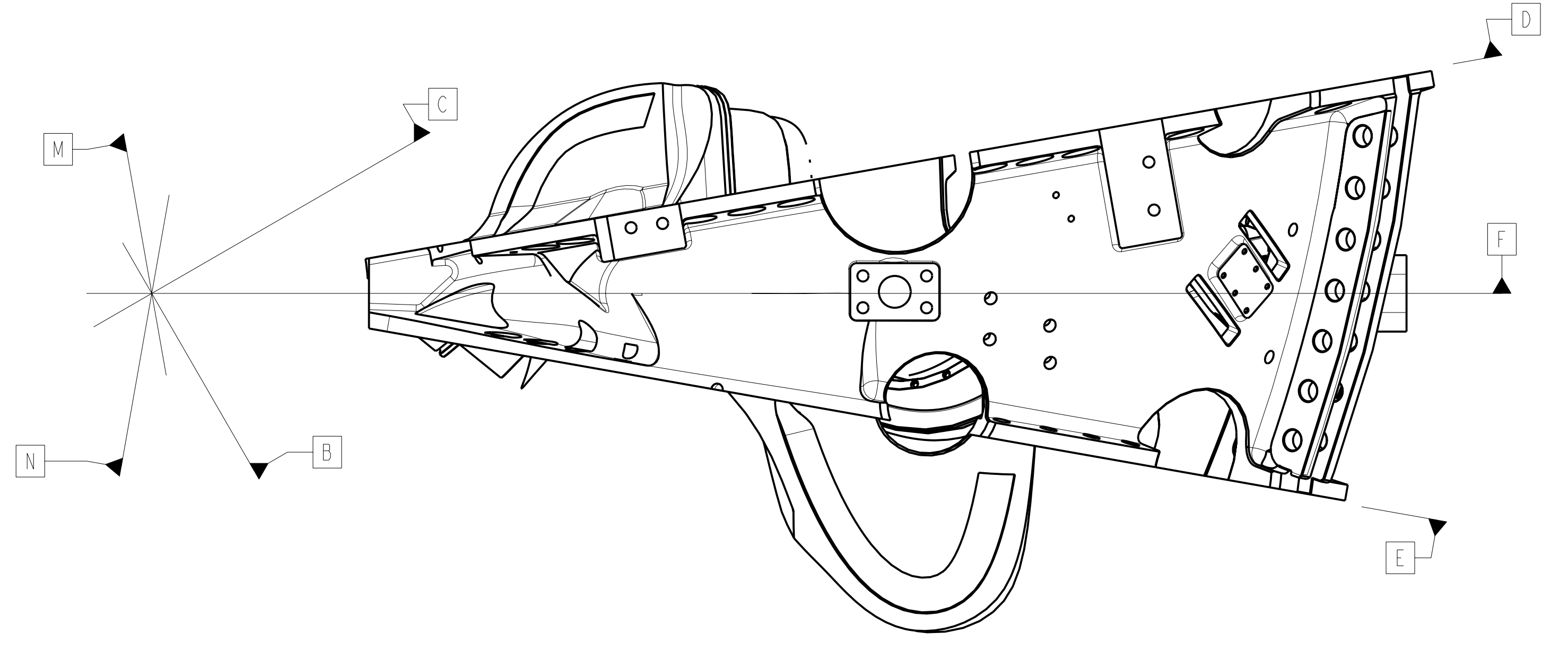
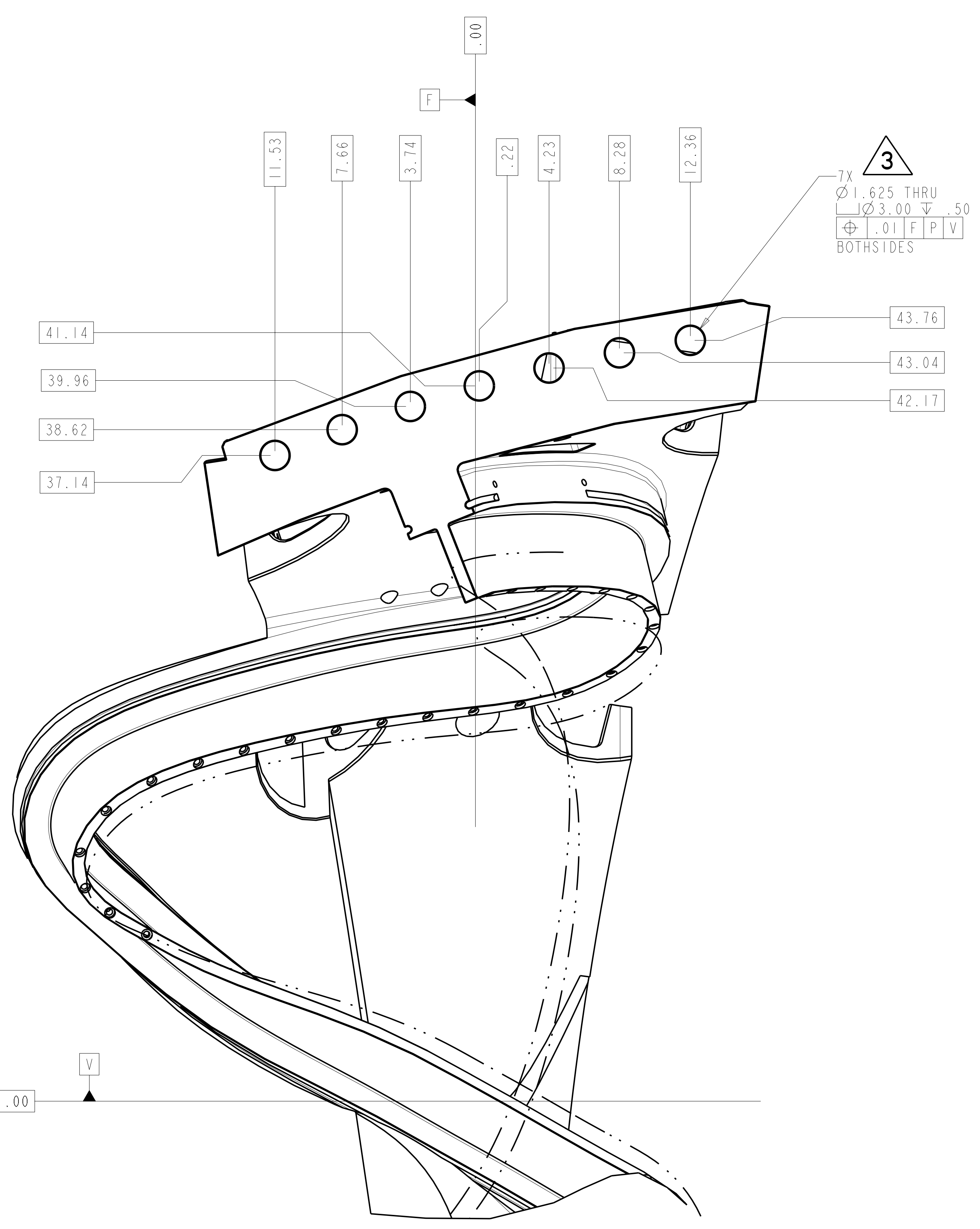
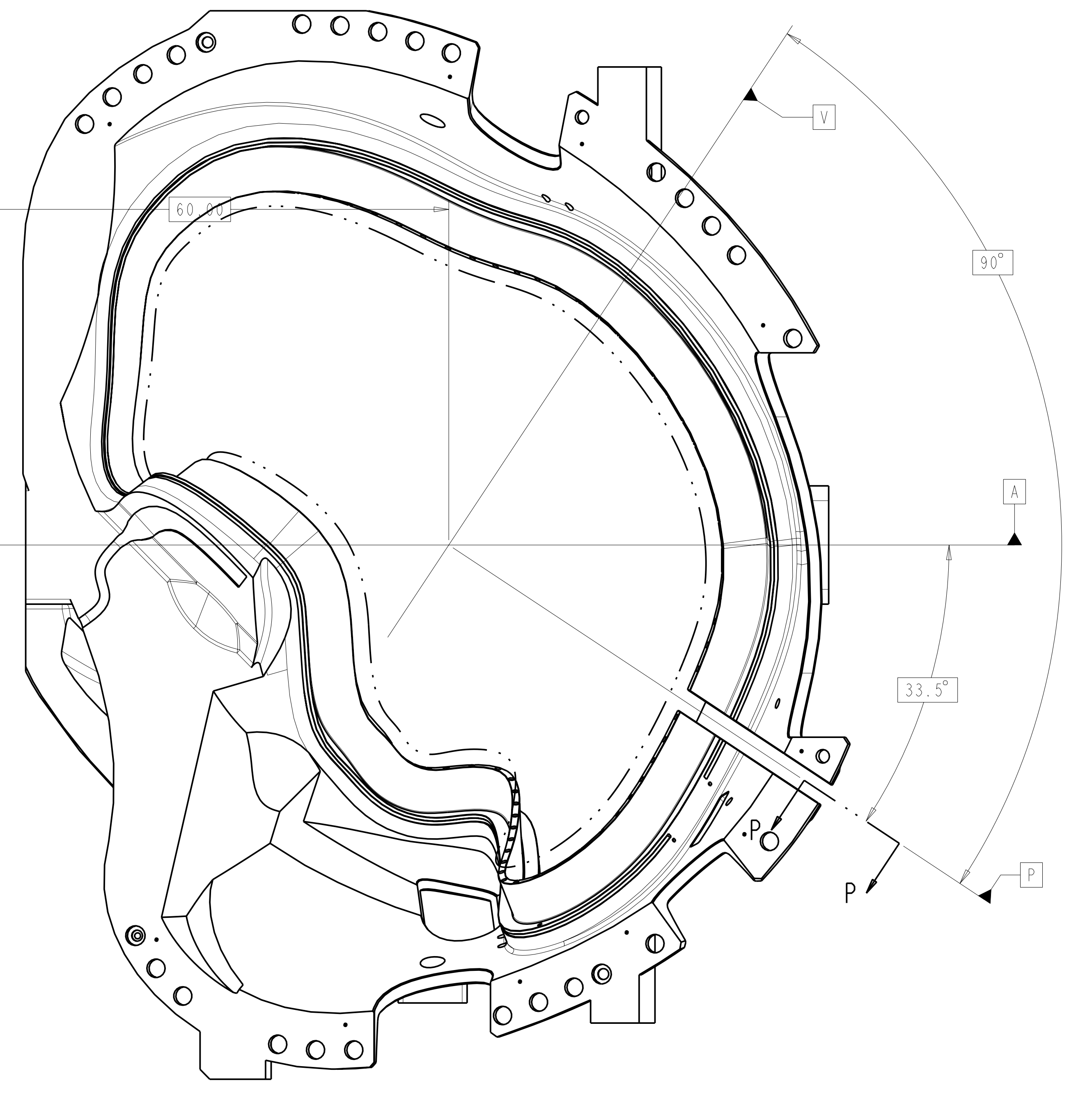
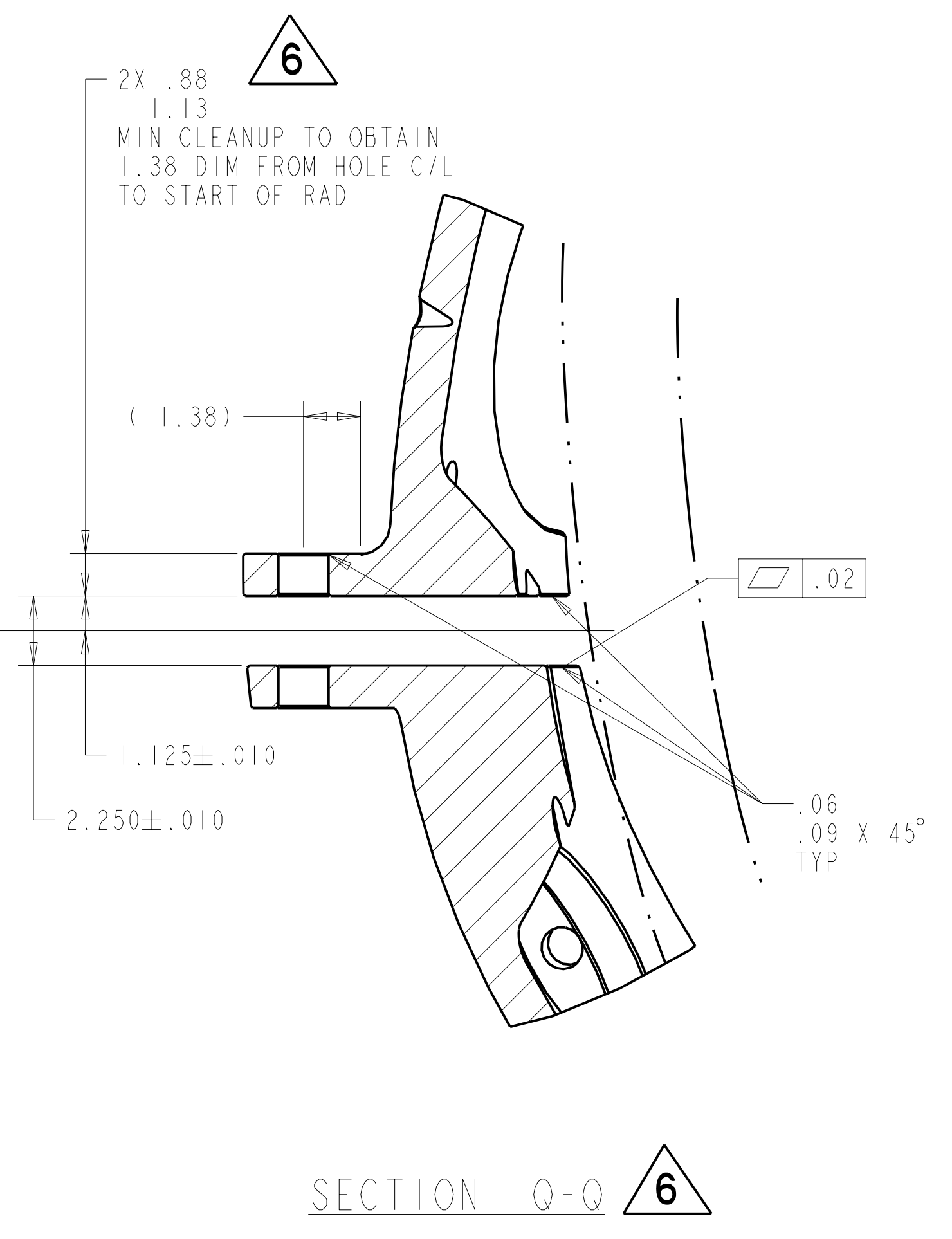
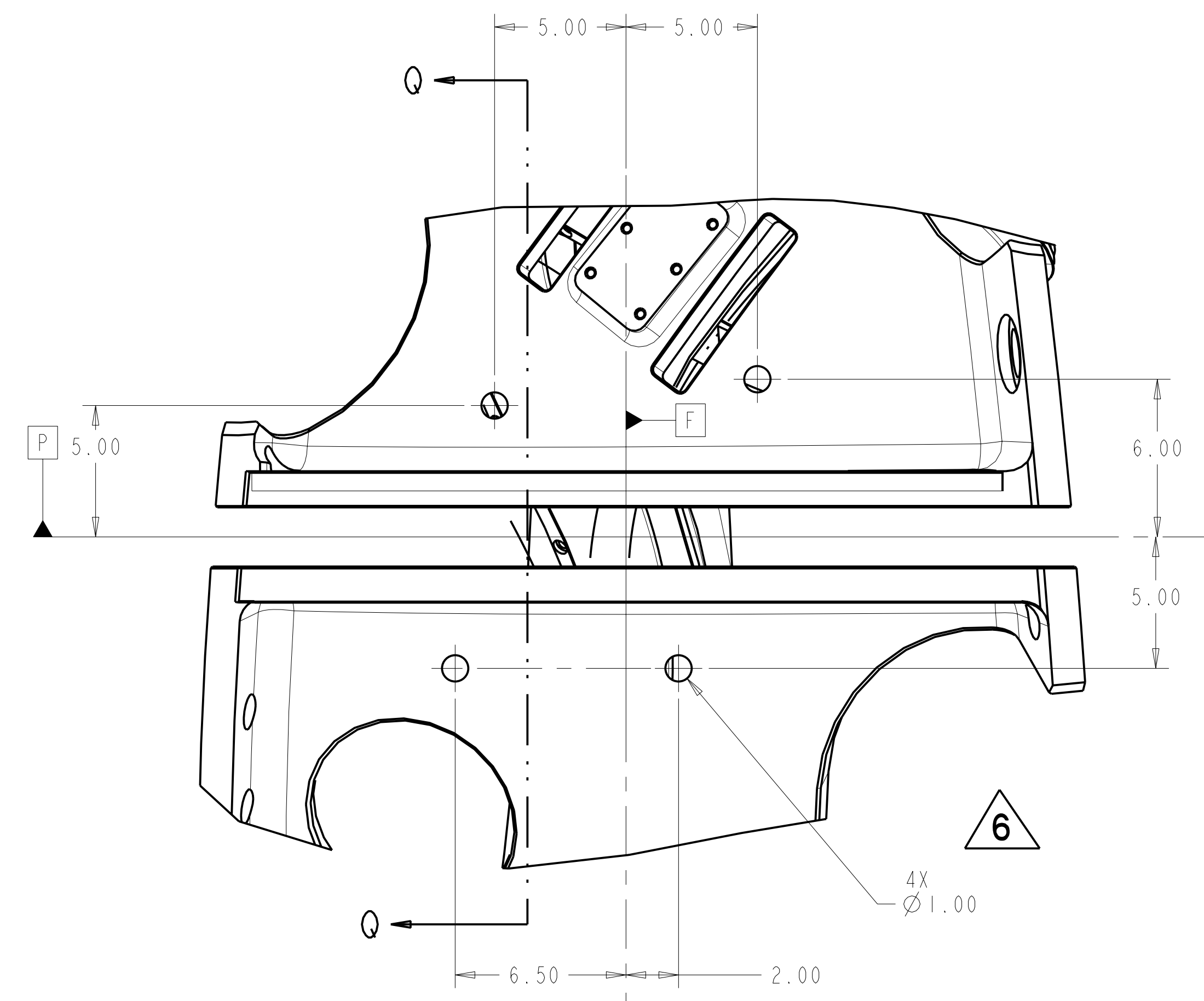

**RELEASED FOR  
FABRICATION / INSTALLATION**  
PPPL Drafting:

Oak Ridge National Laboratory managed for the DEPARTMENT OF ENERGY under <b>UT-BATTELLE</b> U.S. GOVERNMENT CONTRACT DE-AC05-00OR22725 UT-BATTELLE, LLC. Oak Ridge, Tennessee PROJECT NAME:									
<b>NATIONAL COMPACT STELLARATOR EXPERIMENT</b>									
PRODUCTION WINDING FORM TYPE-B									
VERSION NO.	PLANT	BLDG	FL	SHT	OF	TYPE	CLASS		
2	X-10	5700	3	6	12	S	U		
RELEASE LEVEL		SE141-115							
Fabrication									
								REV	9

FOR NOTES AND PARTS LIST SEE SHEET 1

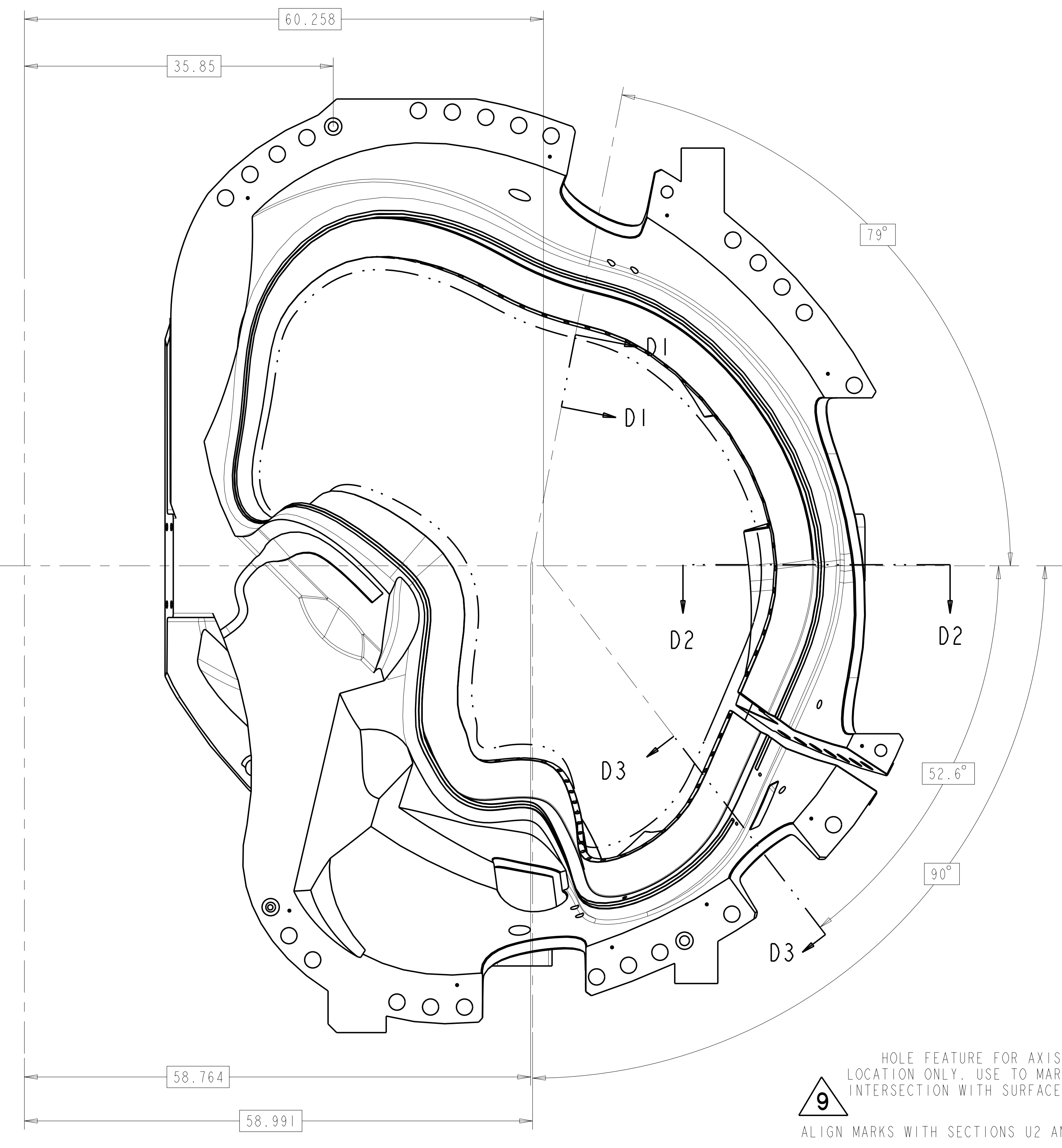

VIEW AT DATUM D  
SCALE 0.13

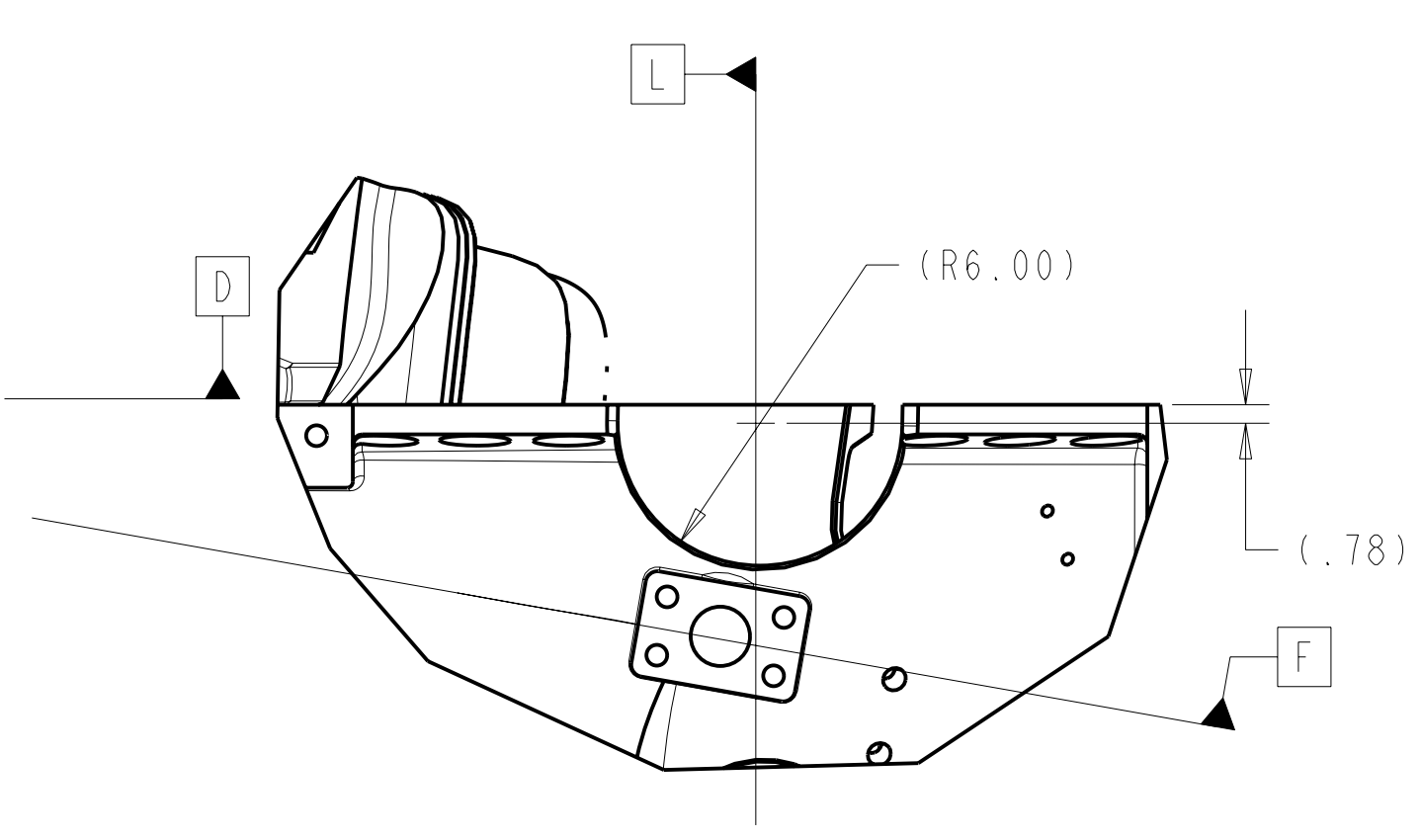

BOTTOM VIEW  
SCALE 0.13

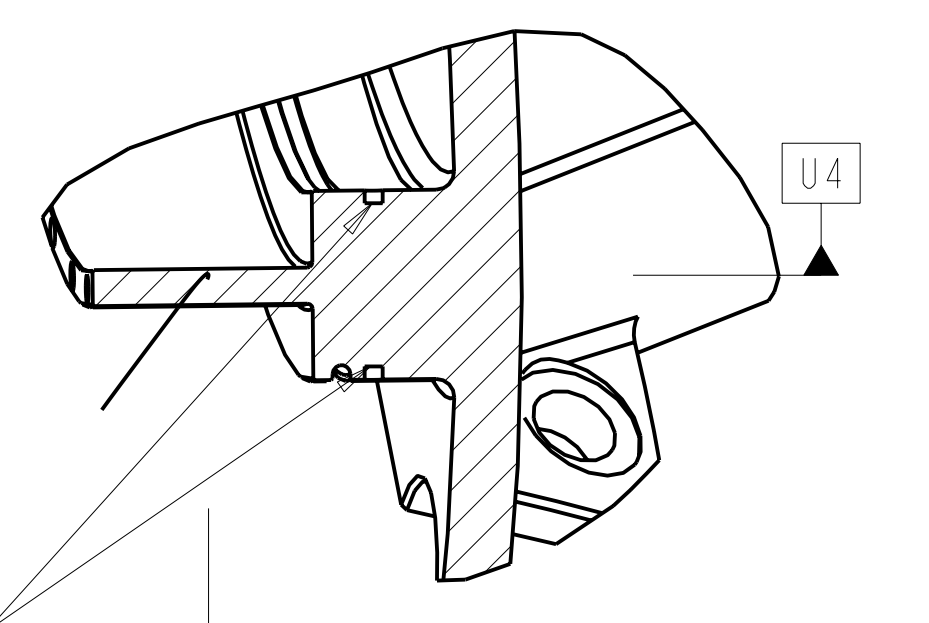

SECTION U3-U3  
SCALE 0.19

9 HOLE FEATURE FOR AXIS LOCATION ONLY. USE TO MARK INTERSECTION WITH SURFACE.  
ALIGN MARKS WITH SECTIONS U2 AND U3.

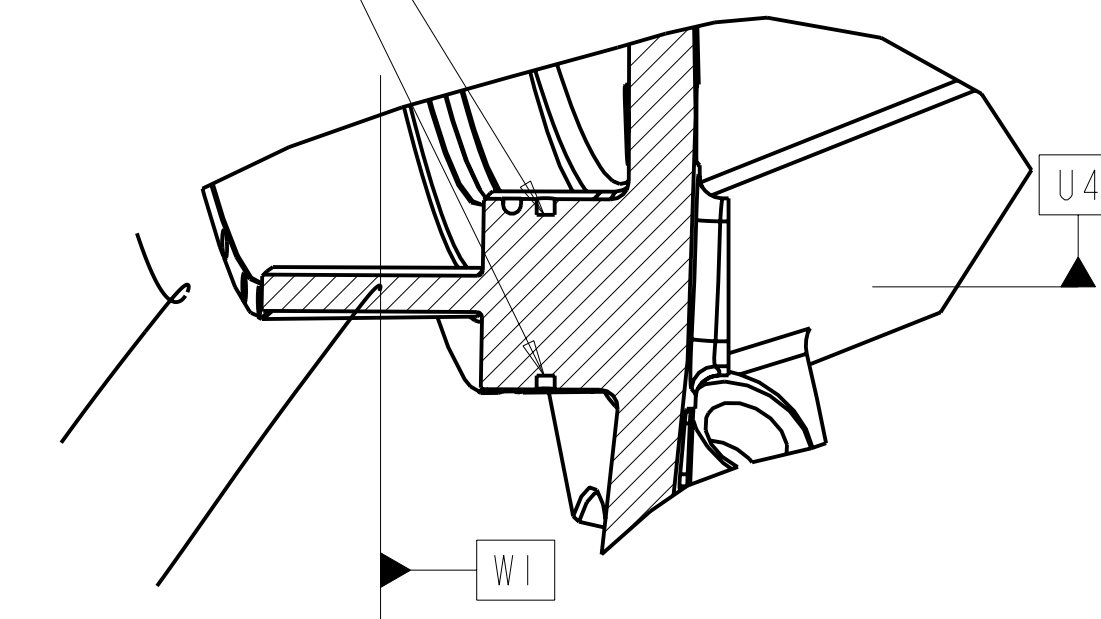

SECTION U2-U2  
SCALE 0.19

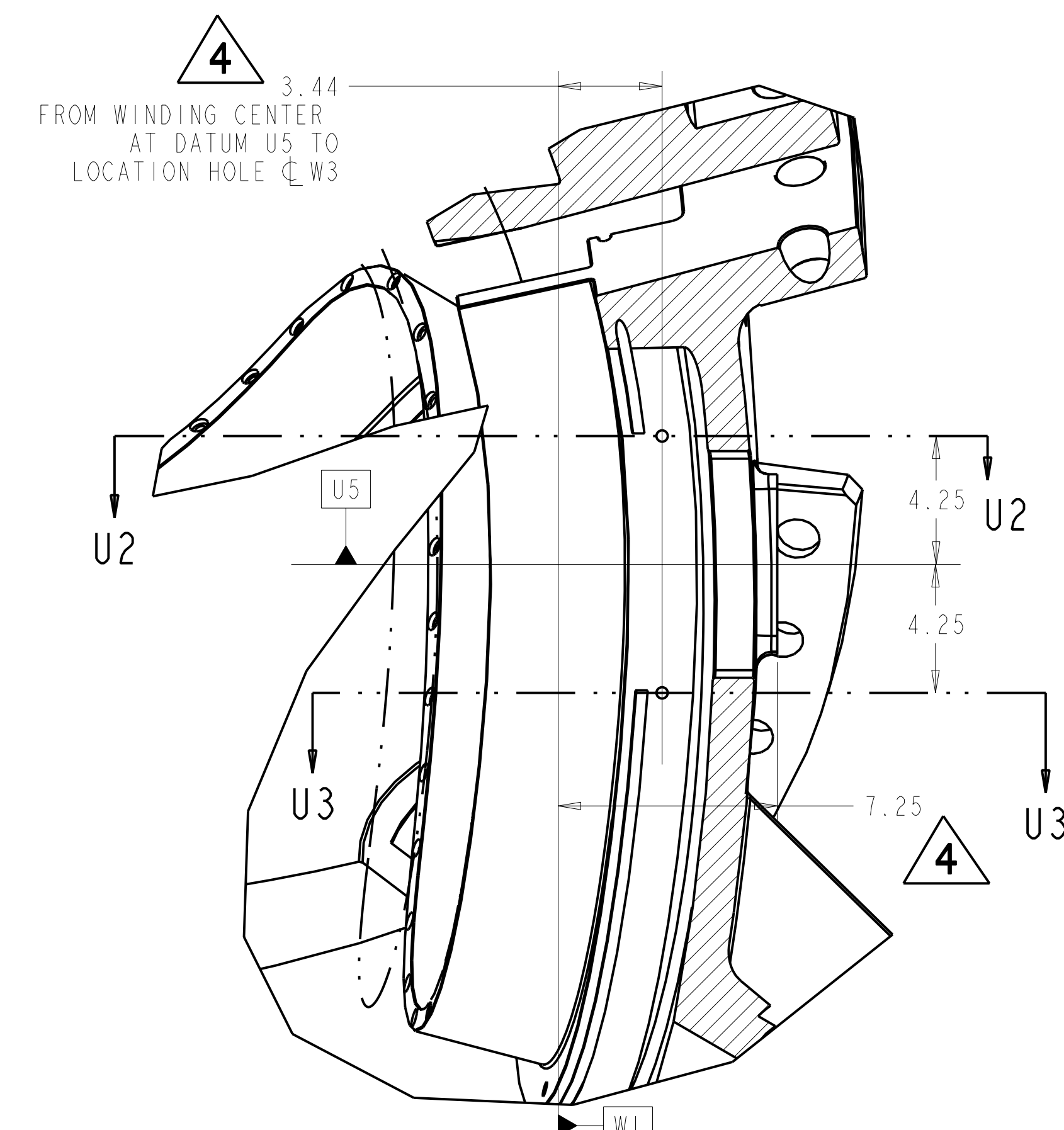

SECTION U1-U1  
SCALE 0.250

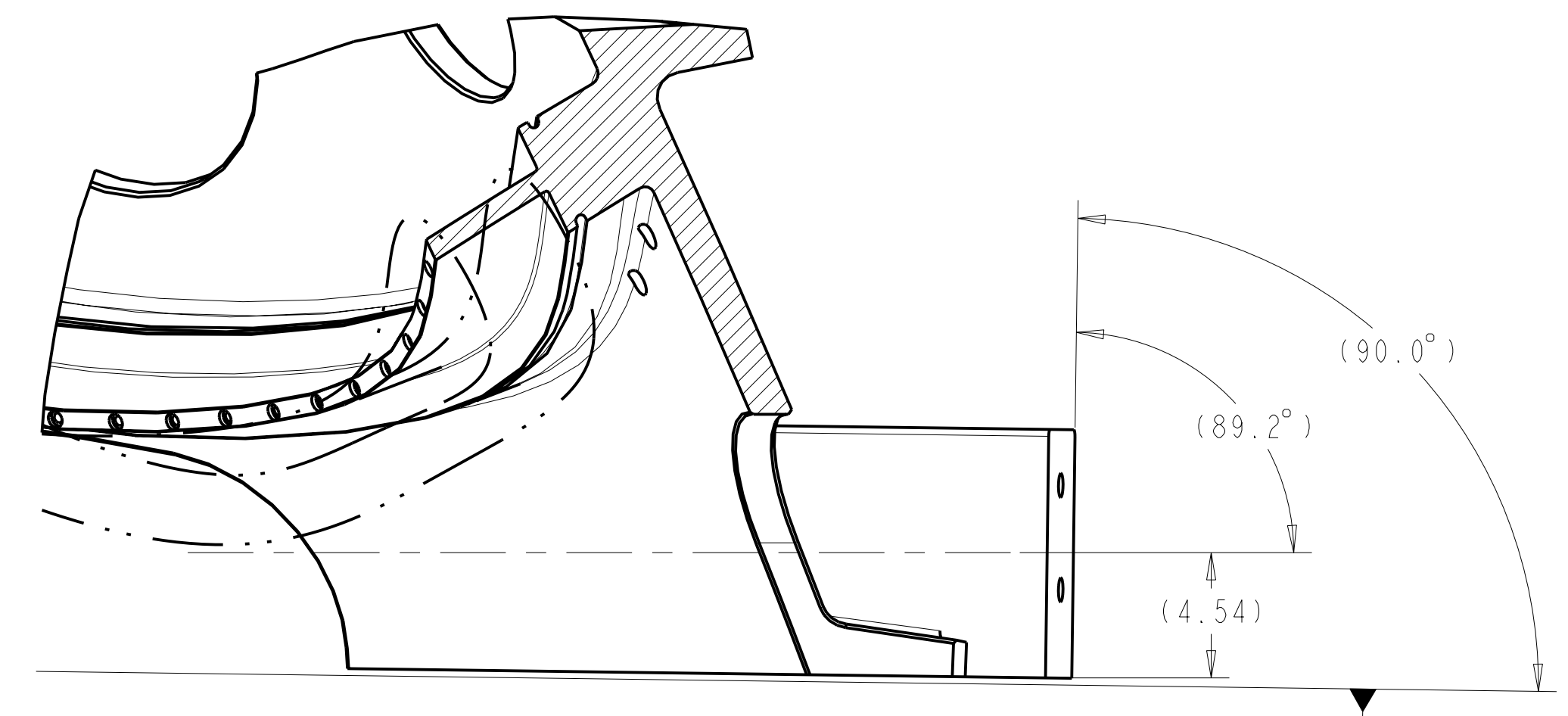

SECTION D1-D1  
SCALE 0.19

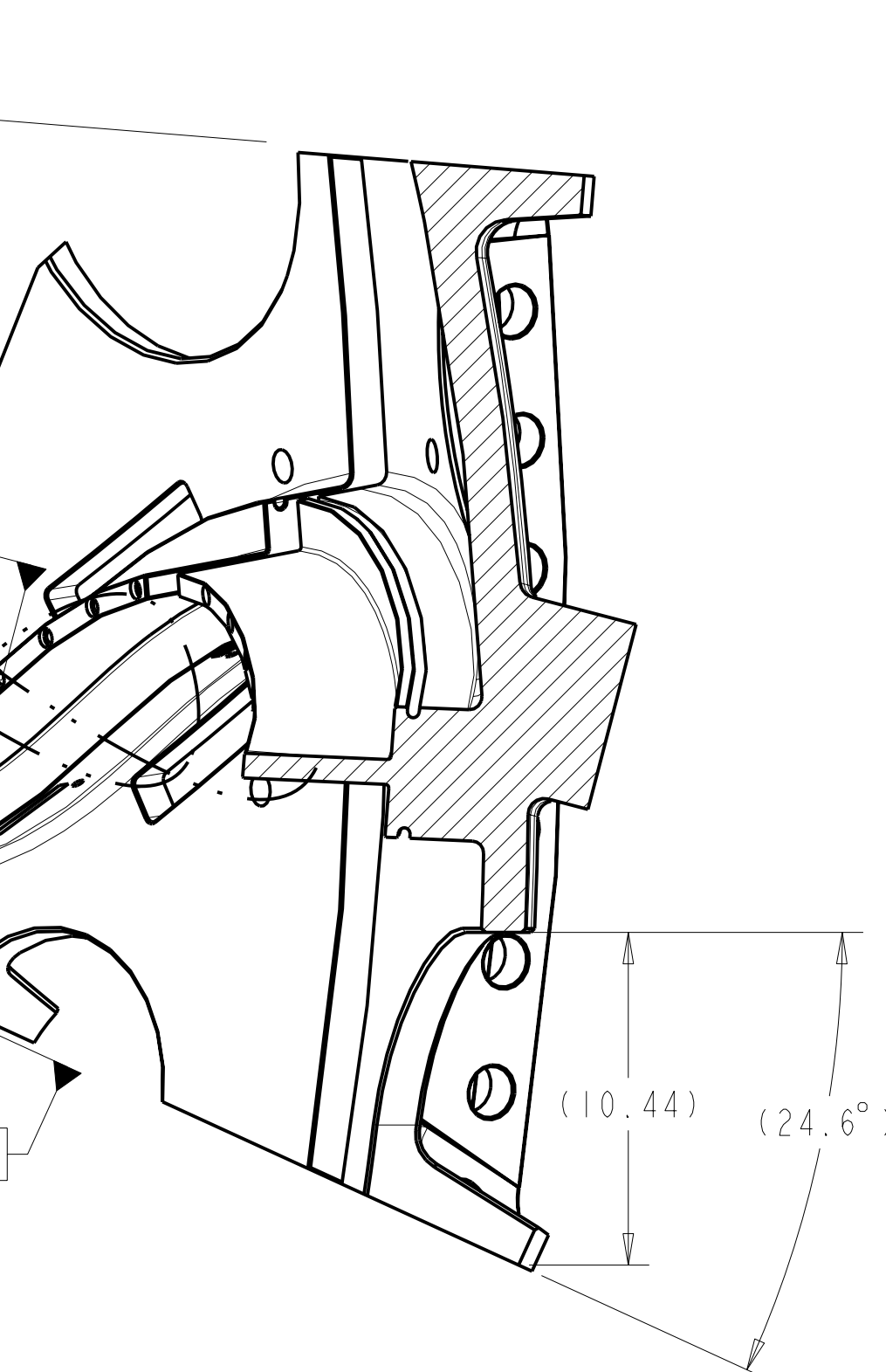
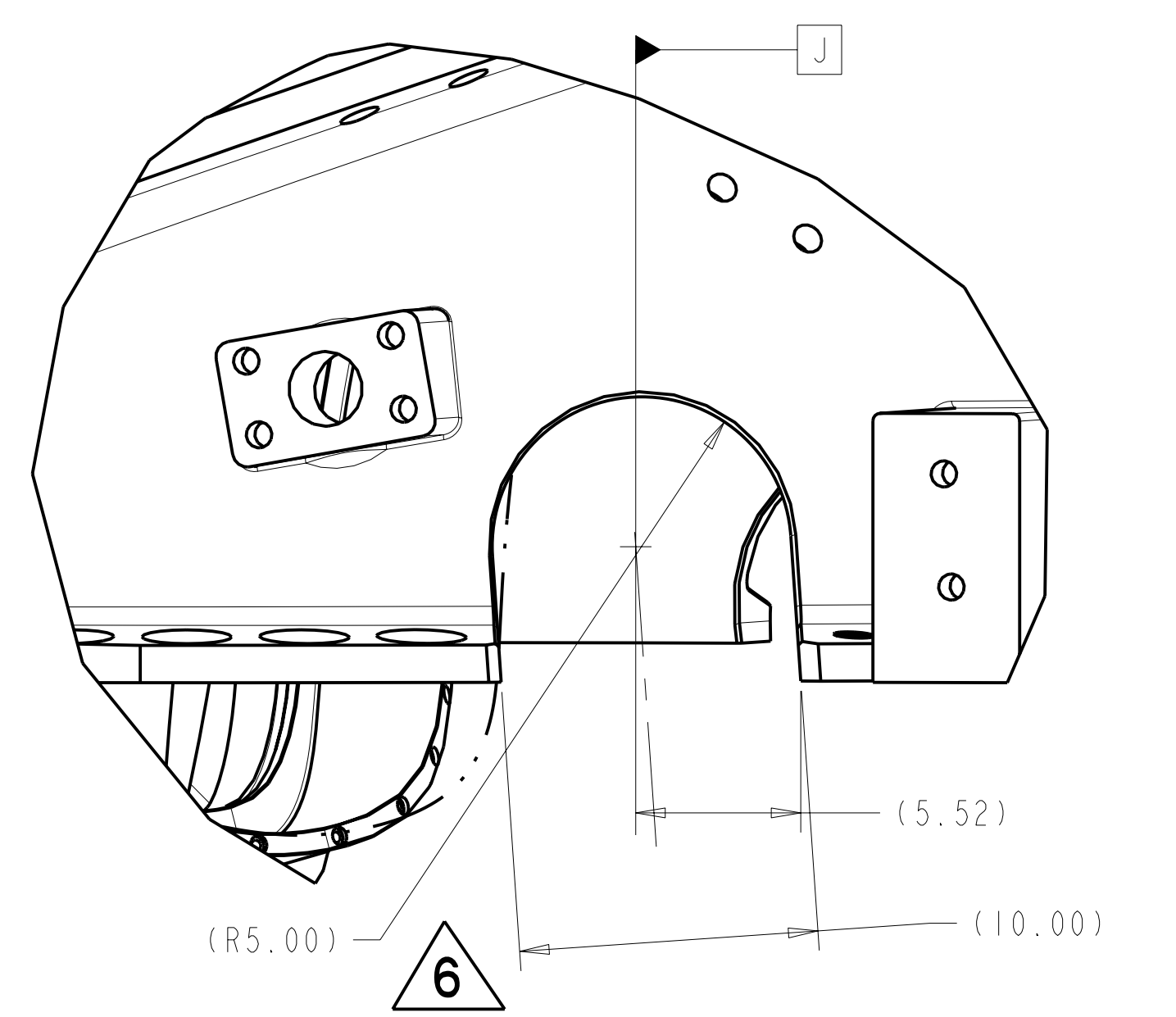

SECTION D3-D3  
SCALE 0.19

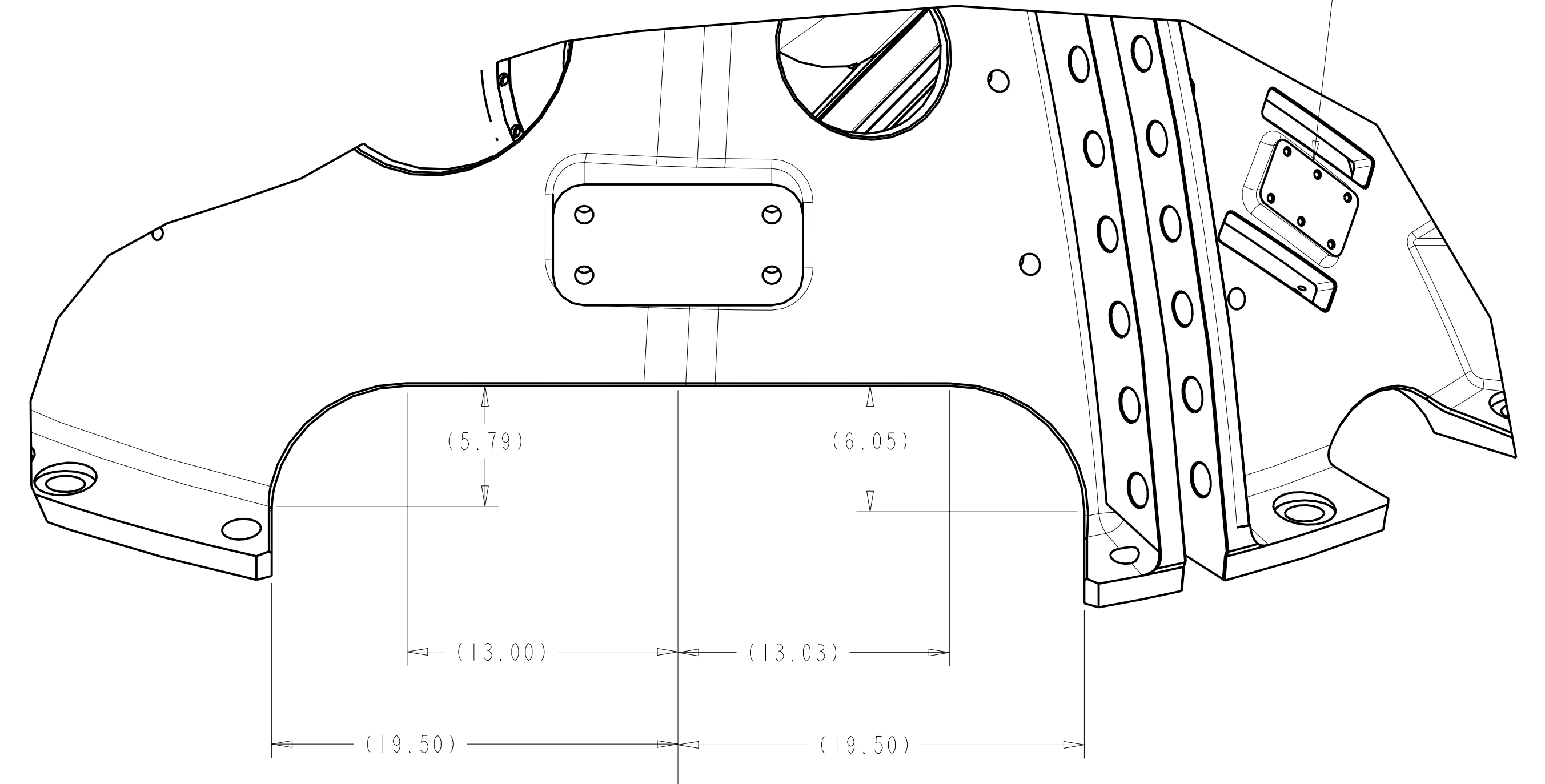

VIEW D4 - D4  
SCALE 0.250

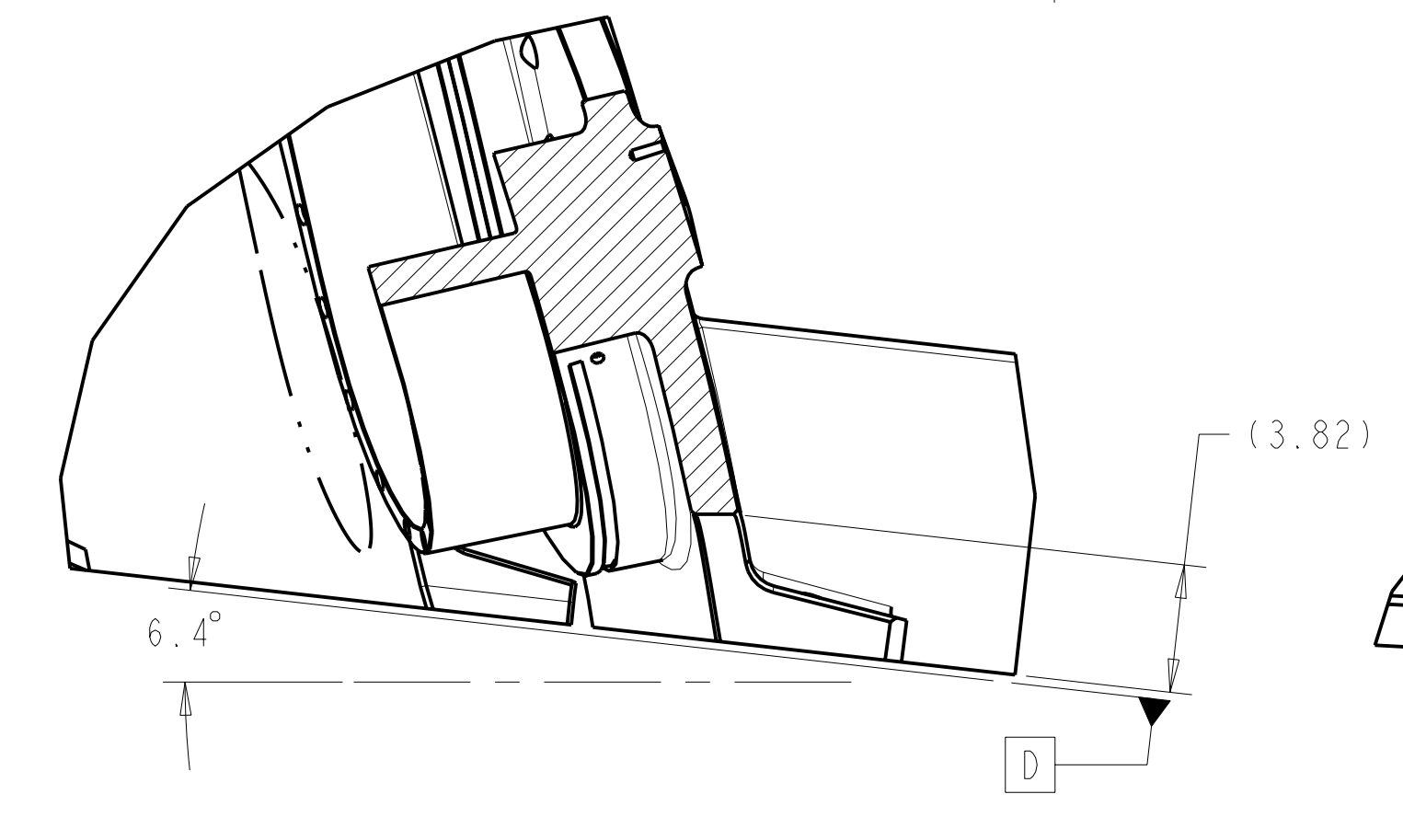

SECTION D4-D4  
SCALE 0.19

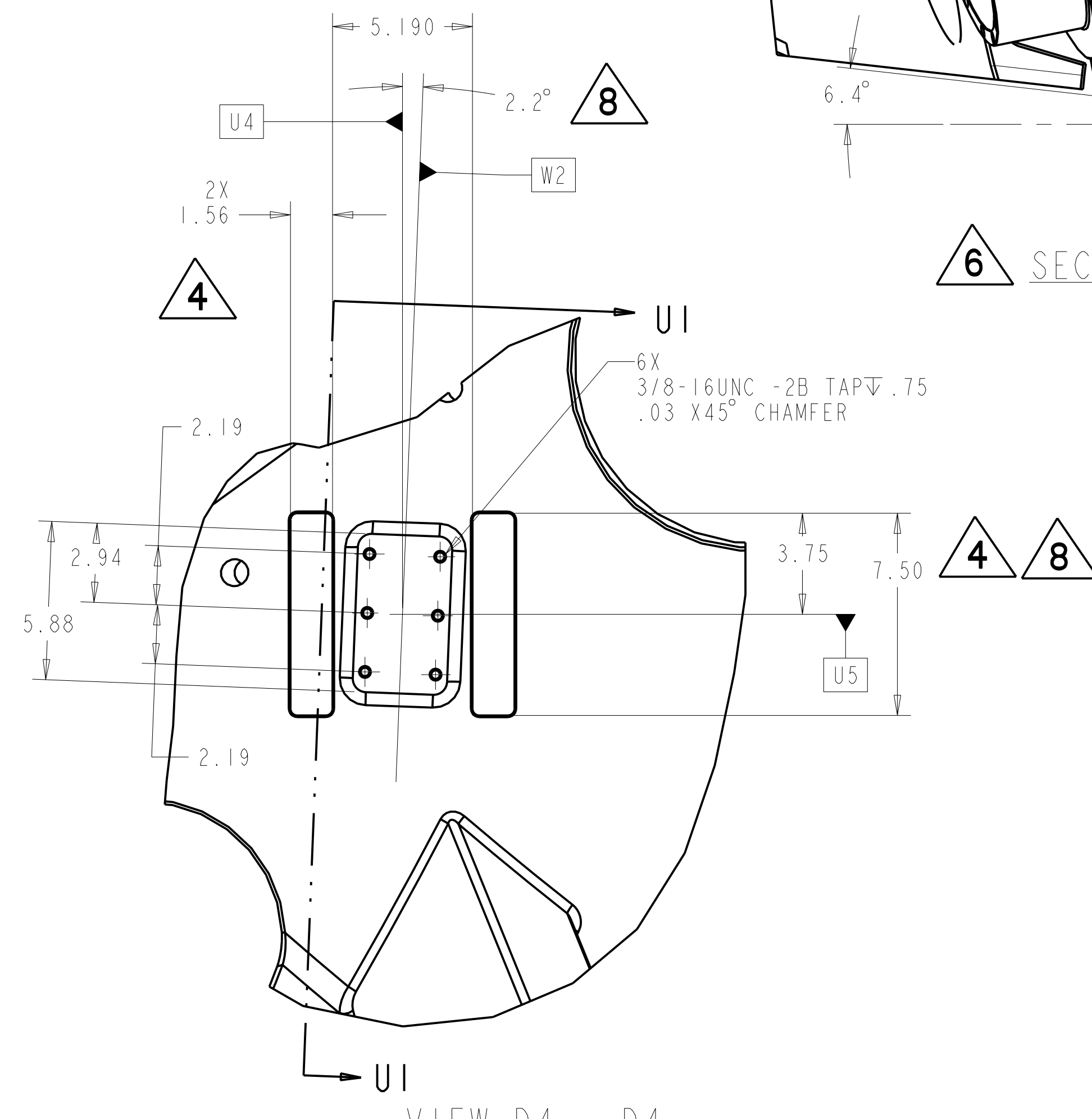

VIEW D4 - D4  
SCALE 0.250

**RELEASED FOR FABRICATION / INSTALLATION**  
PPPL Drafting:

Oak Ridge National Laboratory managed for the DEPARTMENT OF ENERGY under U.S. GOVERNMENT contract DE-AC05-00OR22725 UT-BATTELLE, LLC. Oak Ridge, Tennessee										
PROJECT NAME <b>NATIONAL COMPACT STELLARATOR EXPERIMENT</b>										
PRODUCTION WINDING FORM TYPE-B										
VERSION NO. 2	PLANT X-10	BLDG 5700	FL 3	SHT OF 7	TYPE 12 S	CLASS U				
RELEASE LEVEL Fabrication		SE141-115					REV 9			

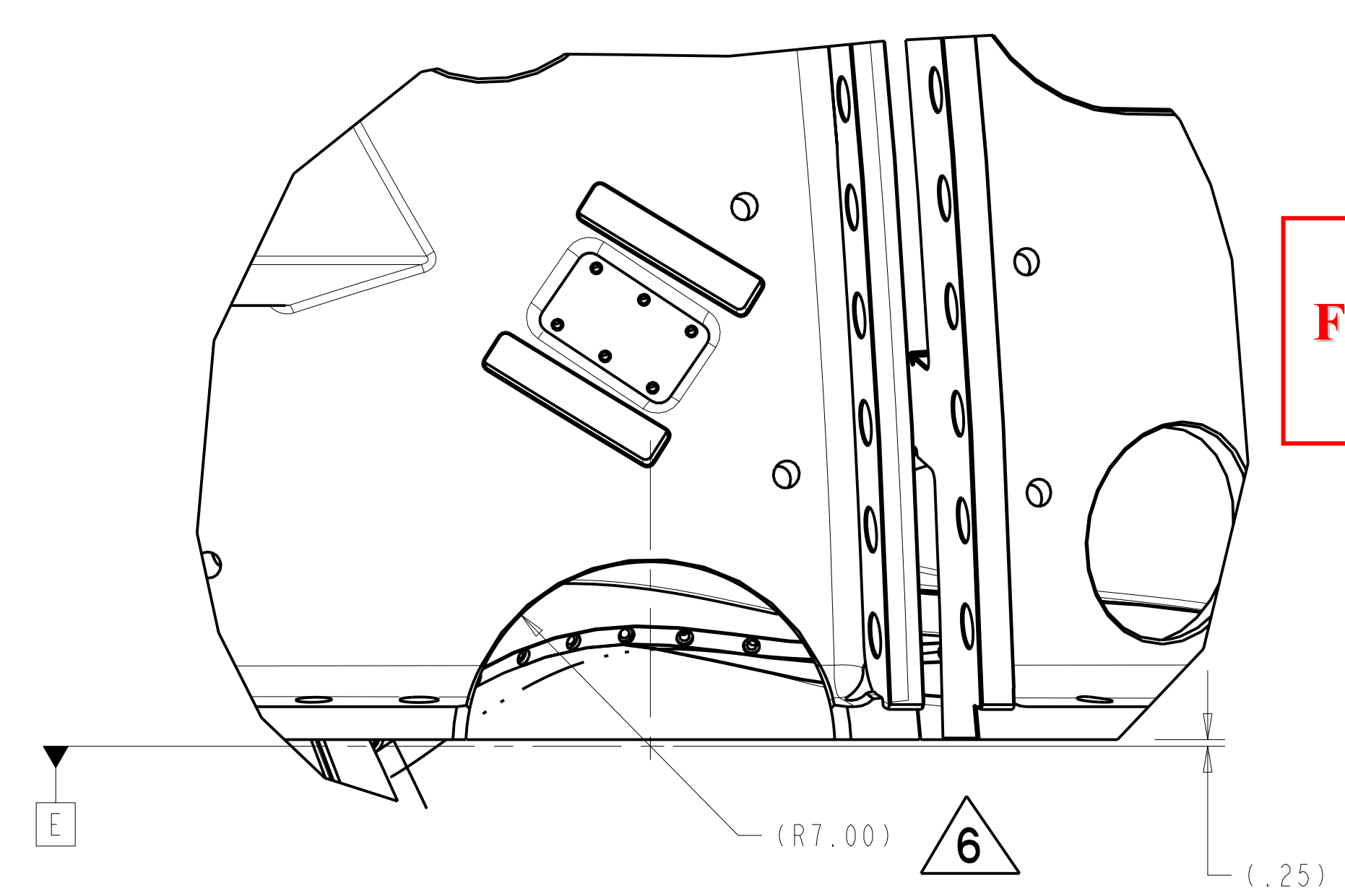
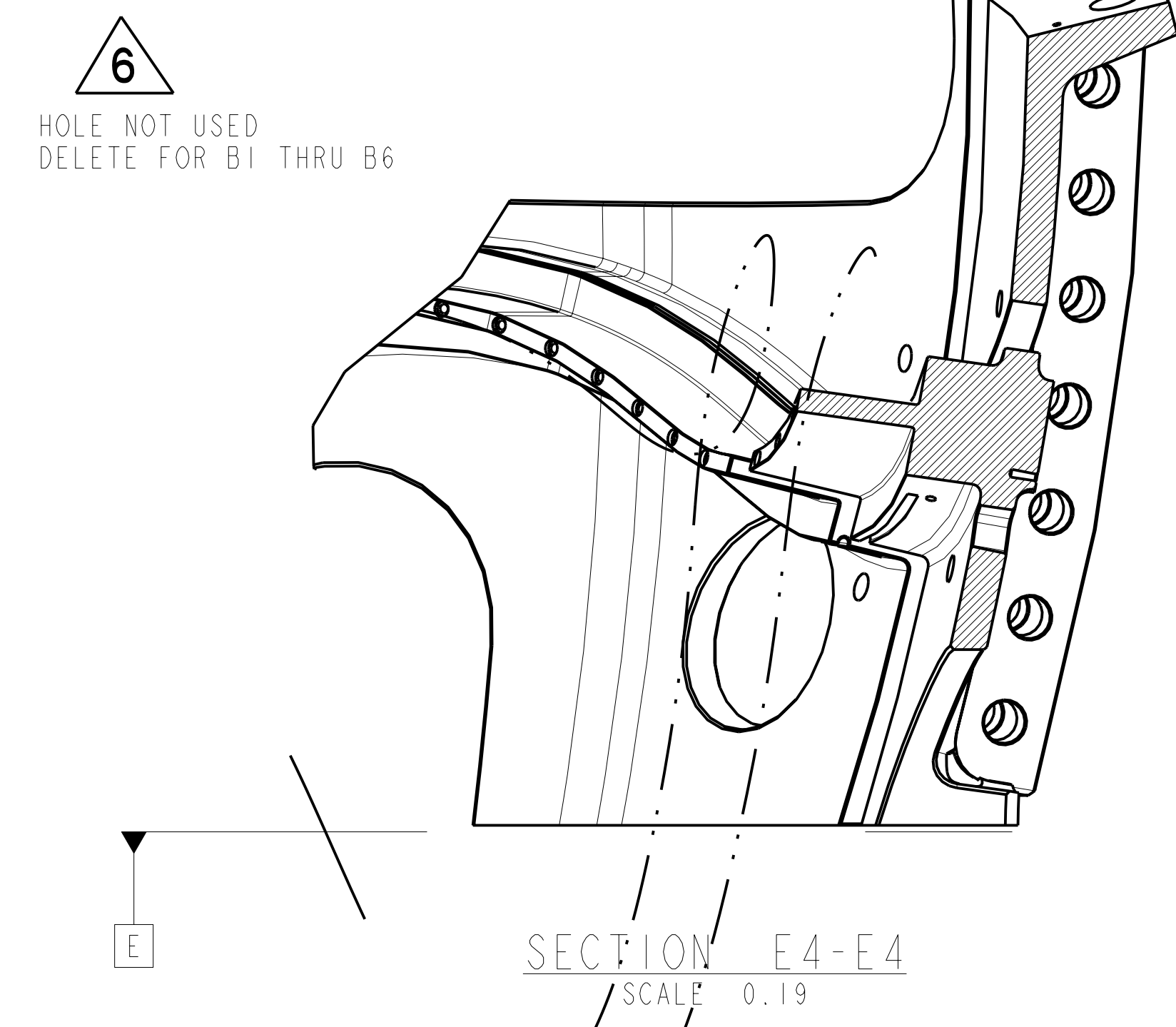
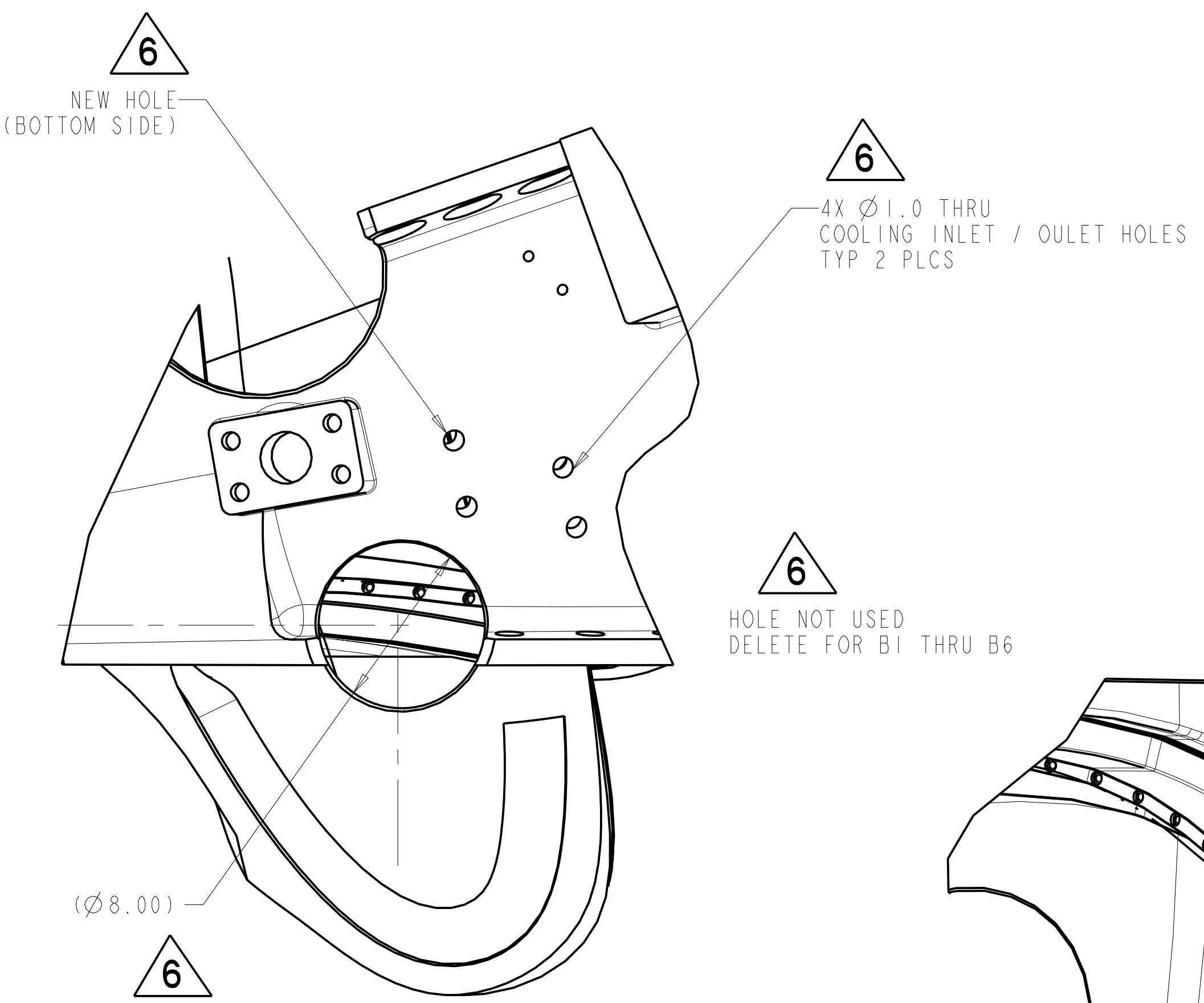
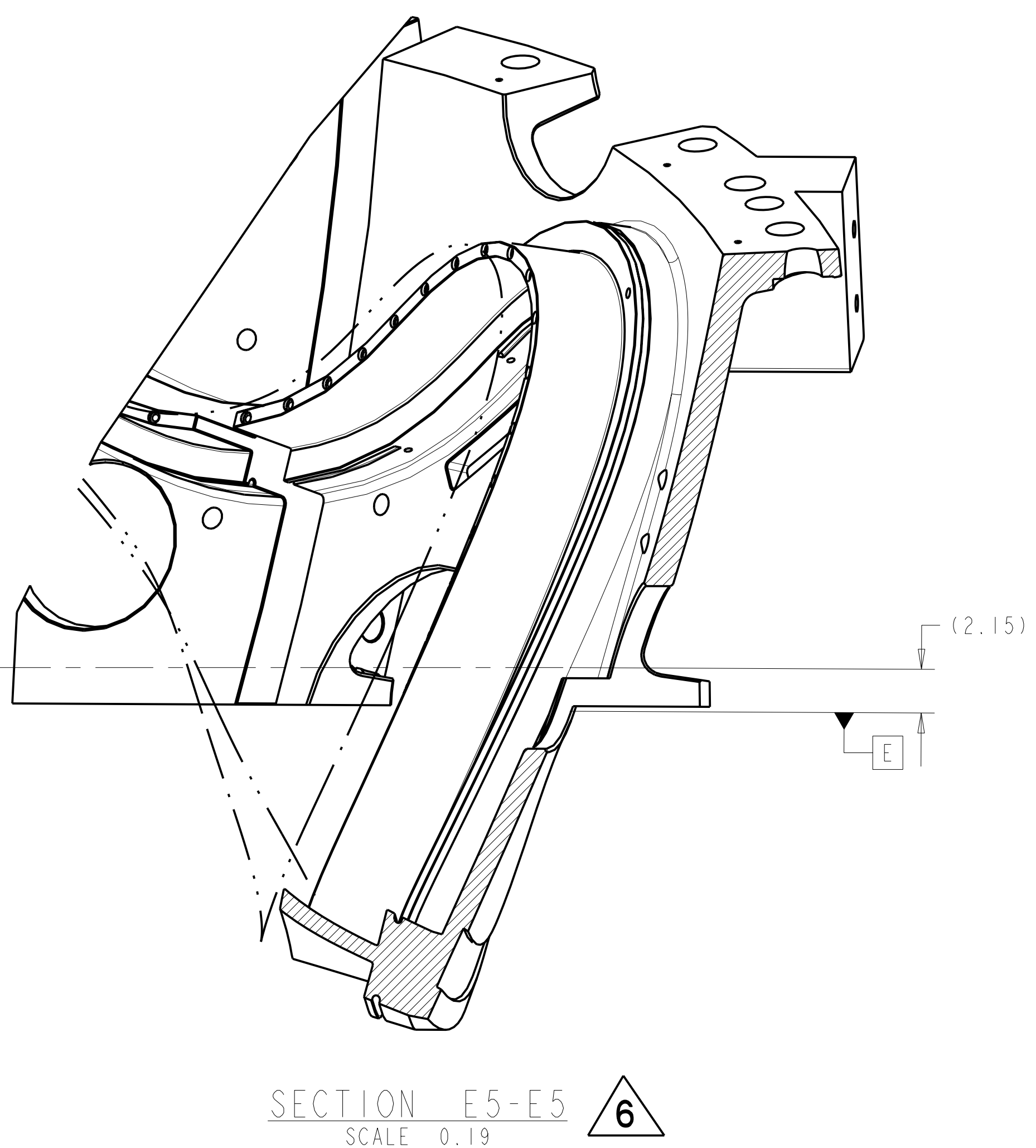
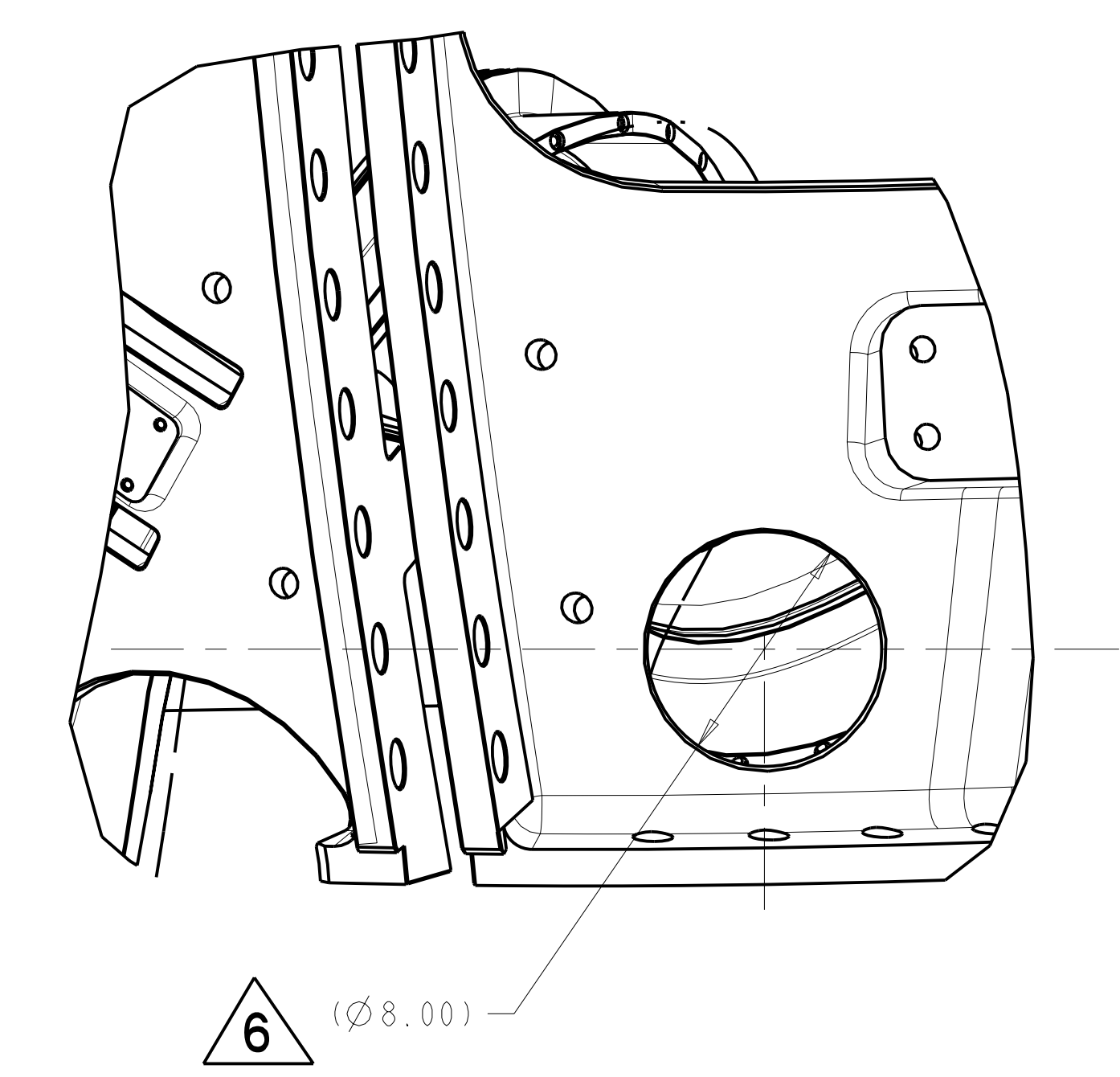
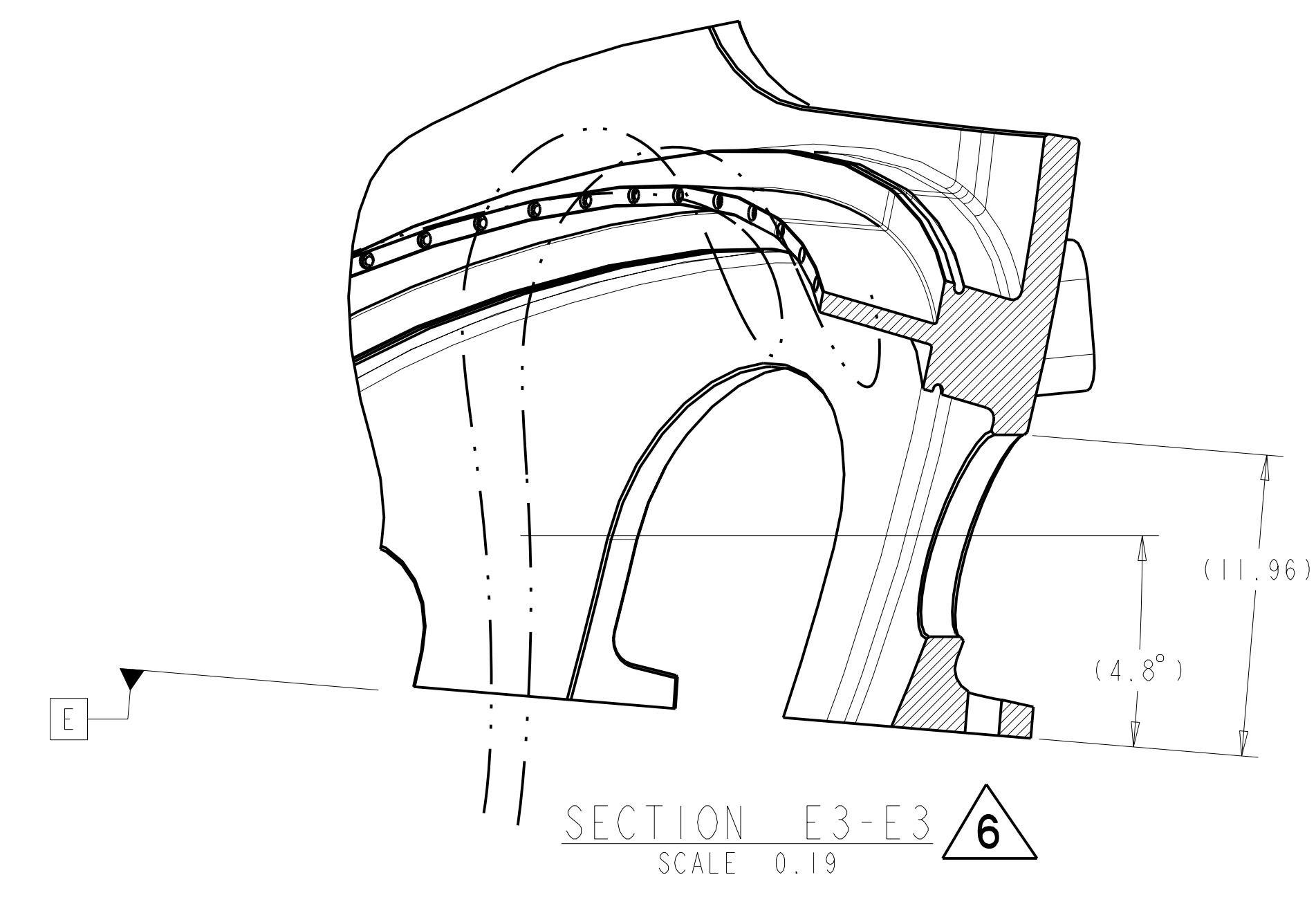
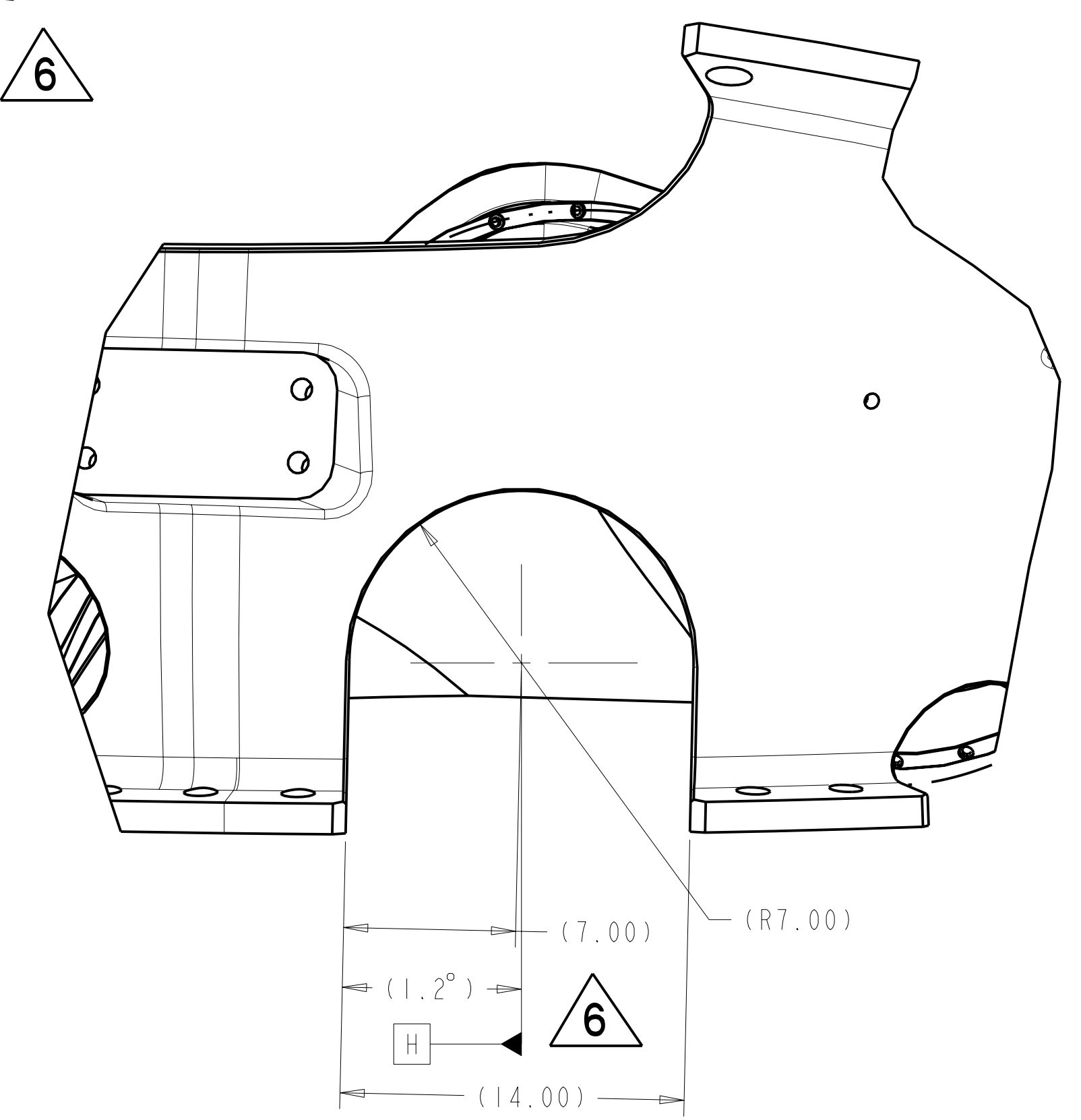
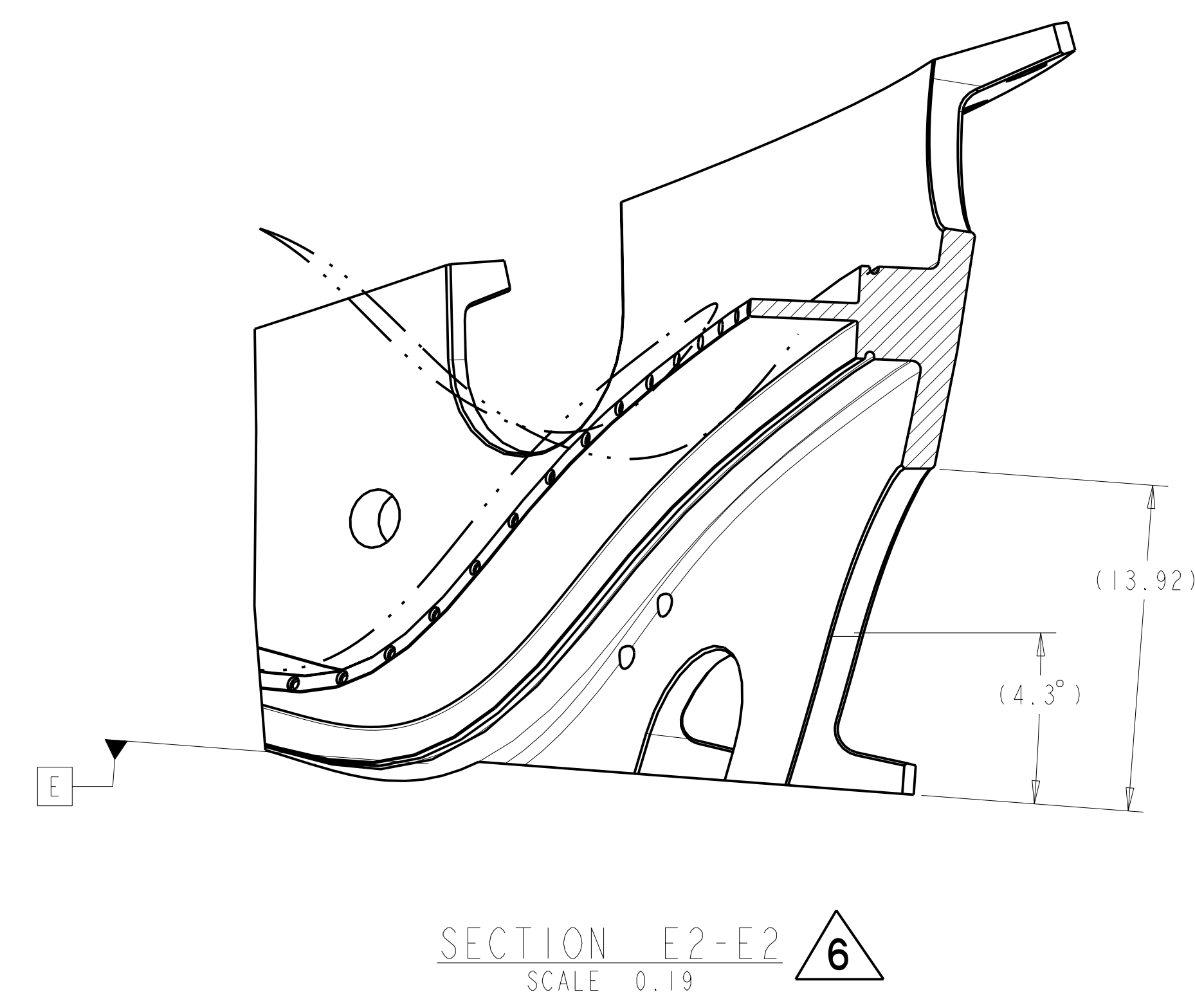
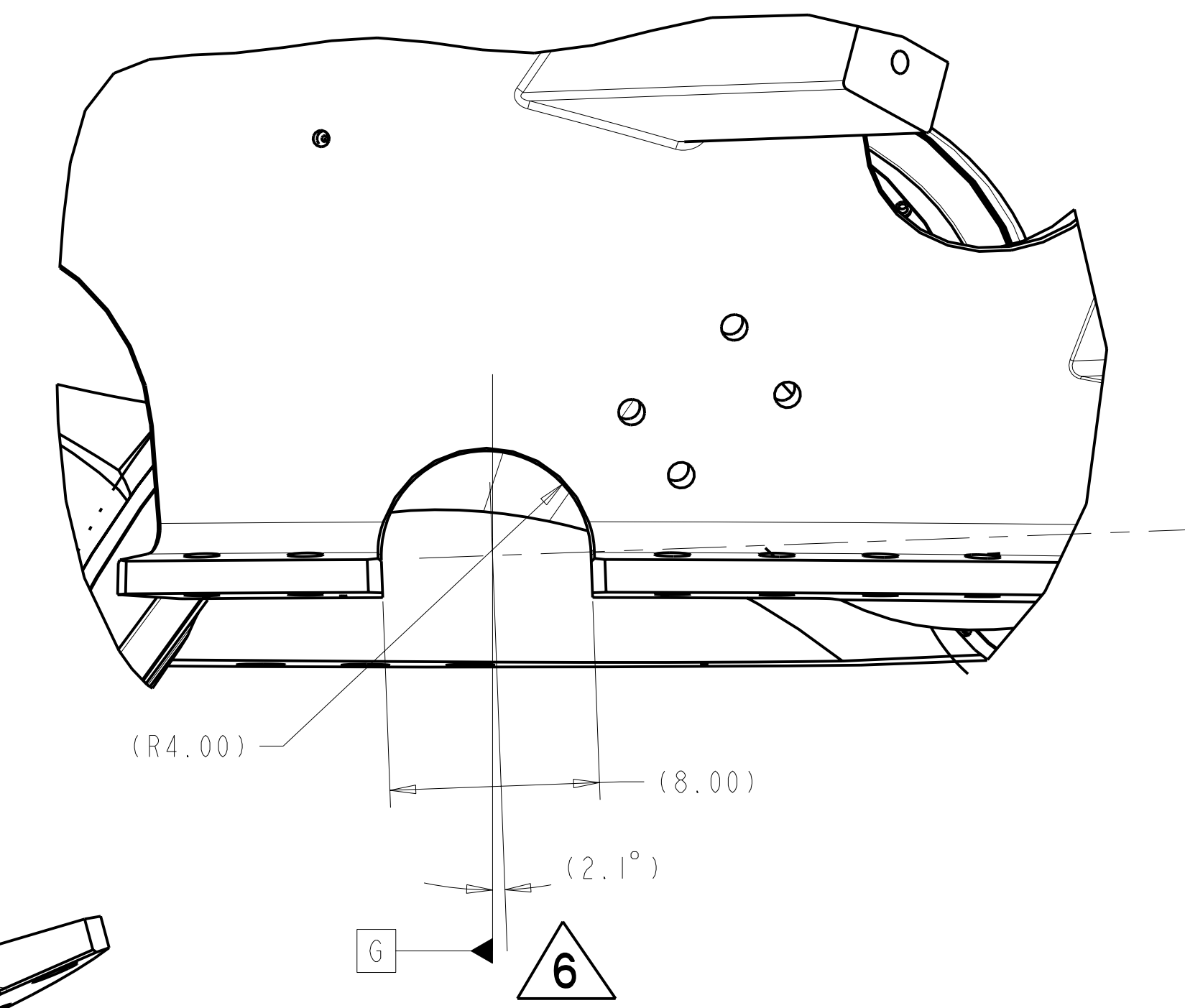
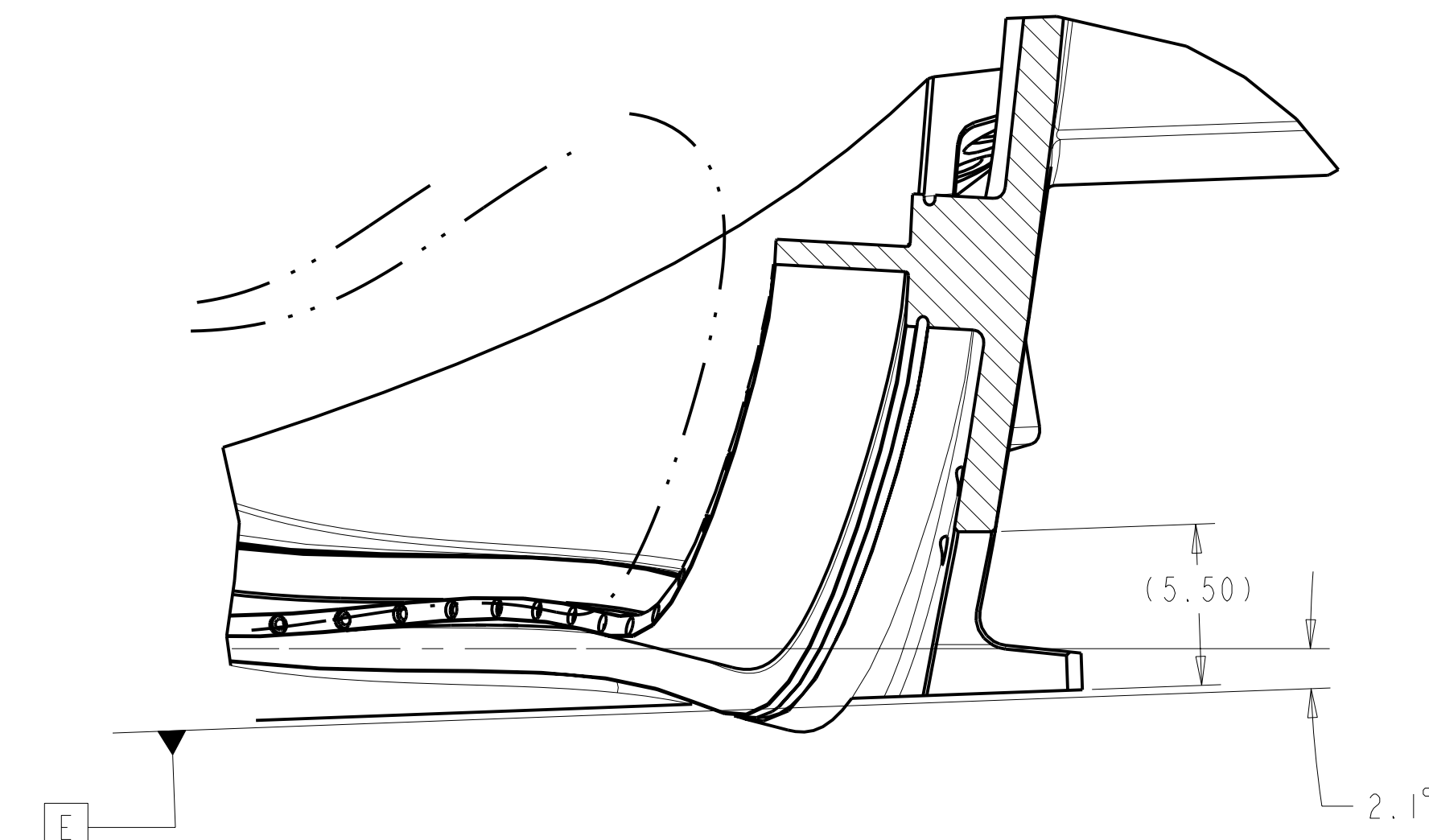
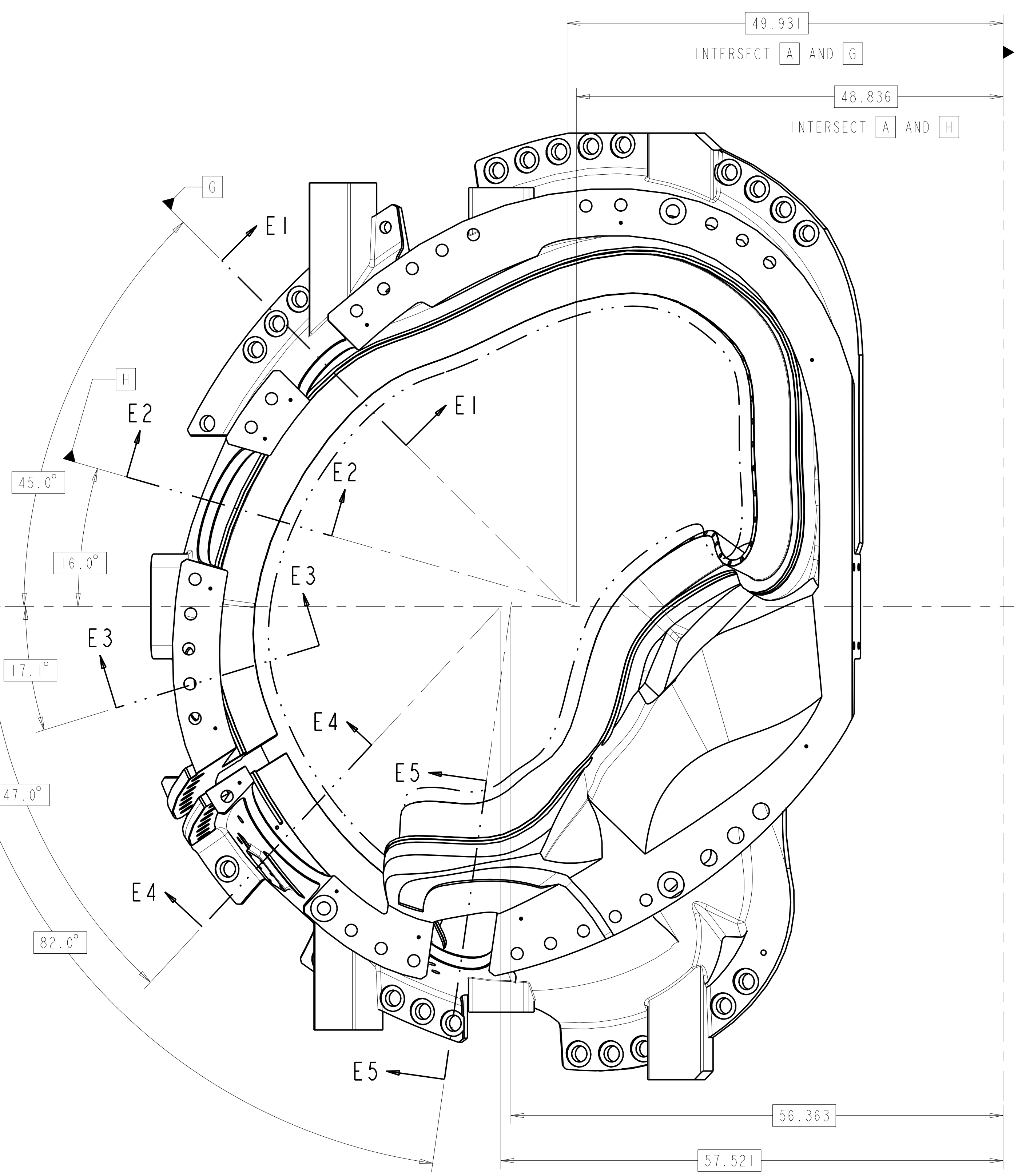

**RELEASED FOR FABRICATION / INSTALLATION**  
PPPL Drafting:

Oak Ridge National Laboratory managed for the DEPARTMENT OF ENERGY under U.S. GOVERNMENT contract DE-AC05-00OR22725 UT-BATTELLE, LLC. Oak Ridge, Tennessee									
PROJECT NAME NATIONAL COMPACT STELLARATOR EXPERIMENT									
PRODUCTION WINDING FORM TYPE-B									
VERSION NO. 2	PLANT X-10	BLDG 5700	FL 3	SHT OF 8	TYPE 12	CLASS S	U U		
RELEASE LEVEL Fabrication		SE141-115					REV 9		



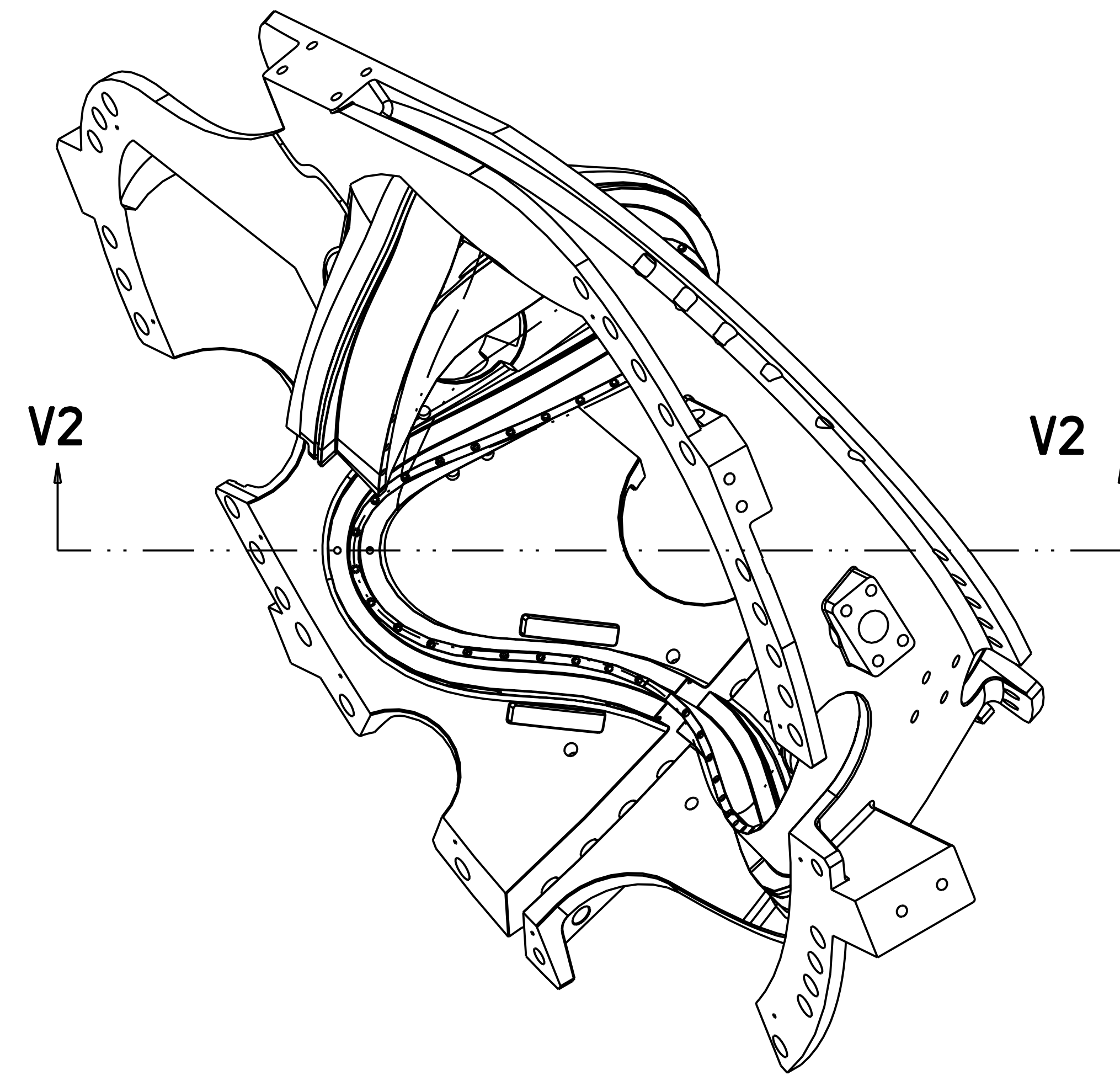

SECTION V2-V2

USE PRO/E MODEL GEOMETRY TO DETERMINE SECTION ORIENTATION HOLE ORIENTATION NOT CRITICAL

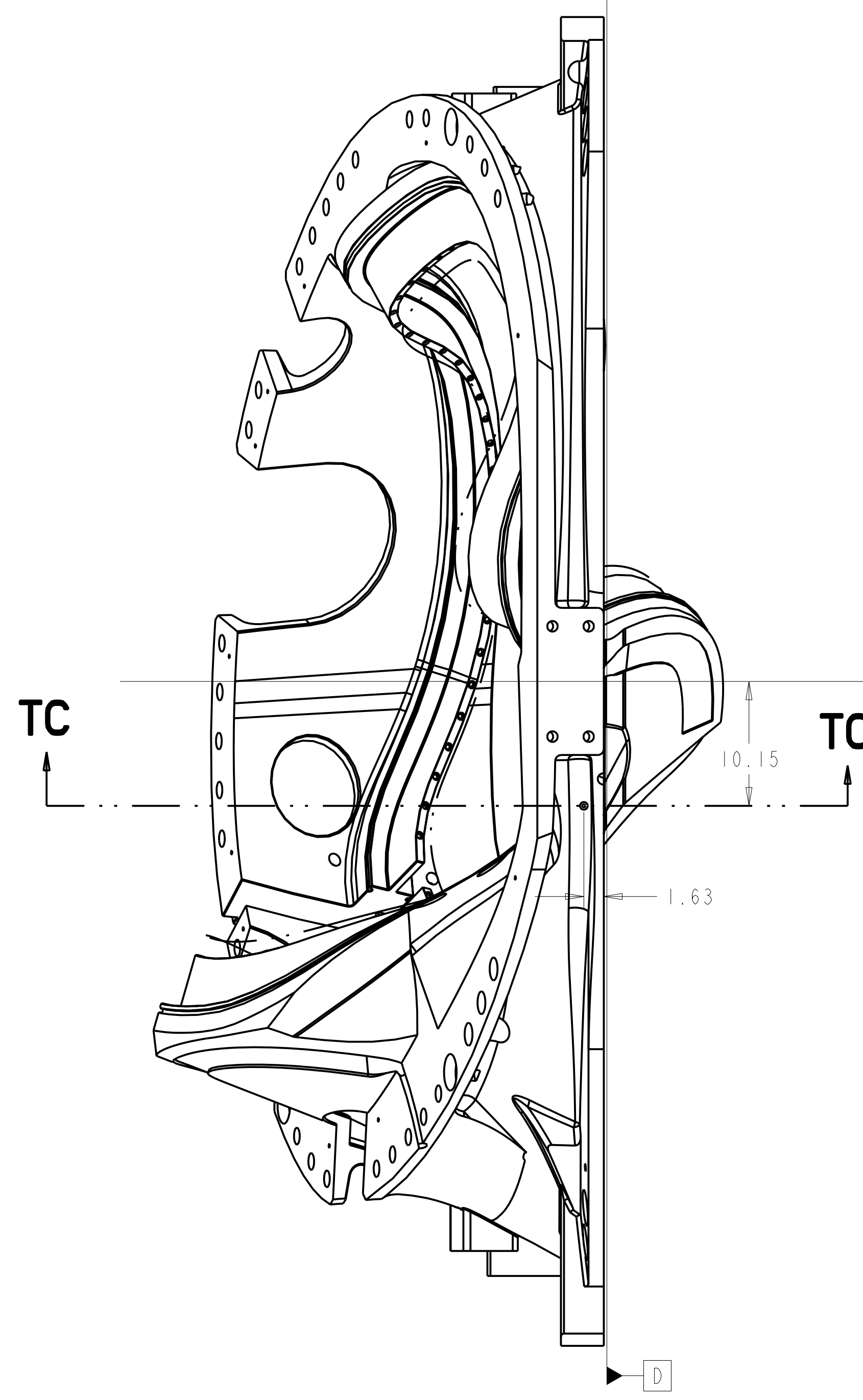

SECTION TC-TC

WAS TC1

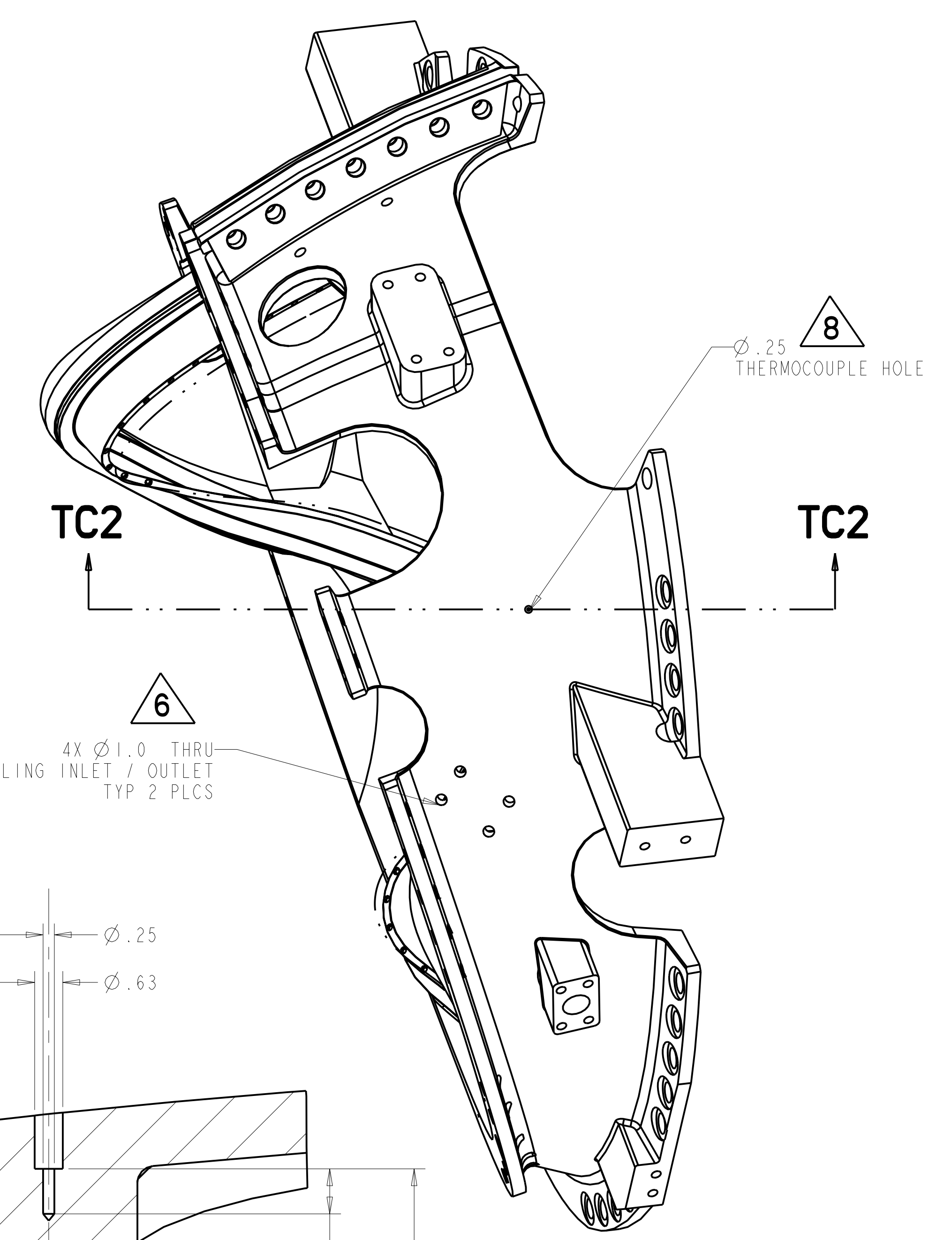

SECTION TC2-TC2

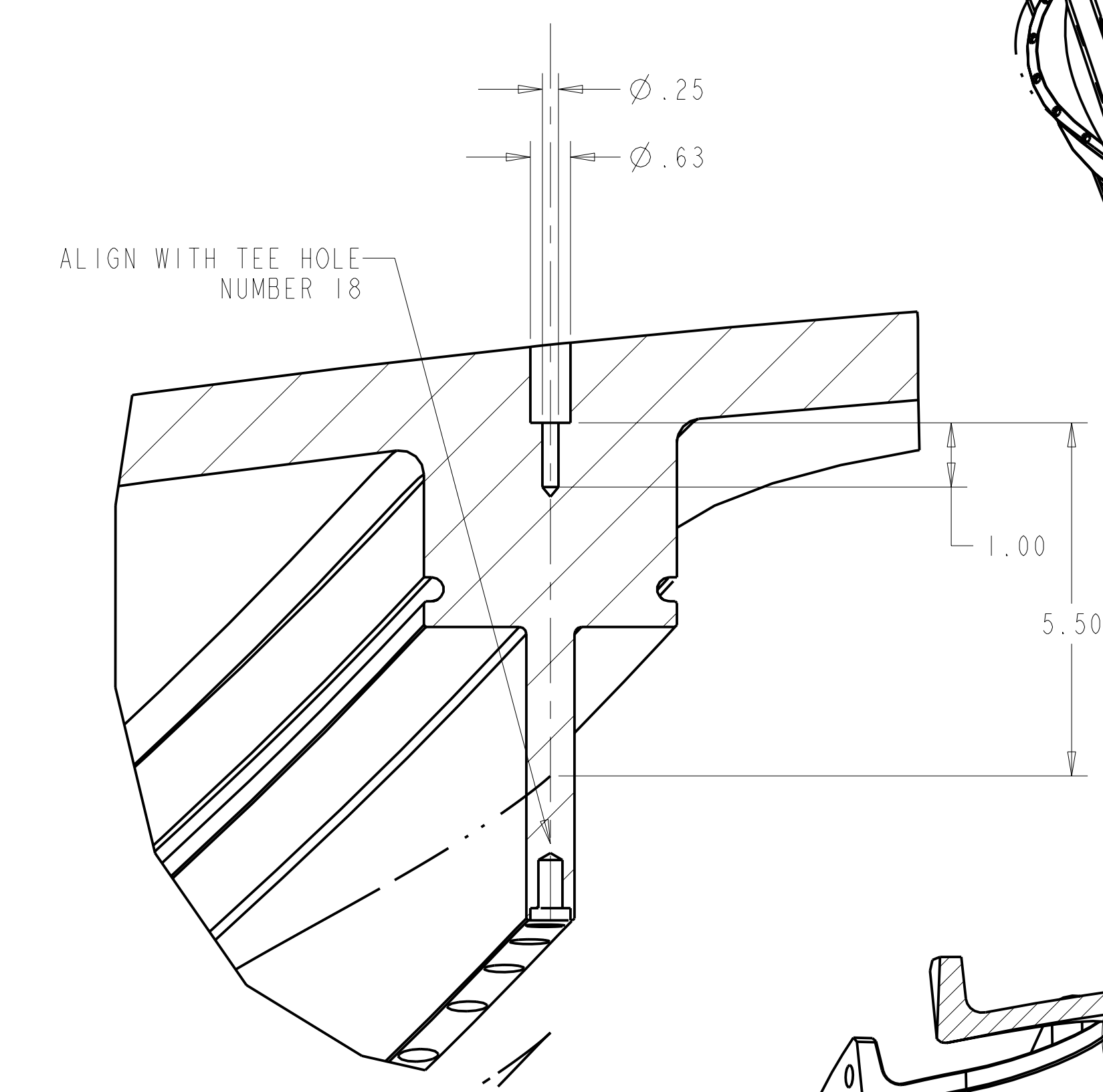

DETAIL D SCALE 0.50

2X ON PLANE NORMAL AT WINDING CENTER CURVE BETWEEN TEE HOLE LOCATIONS 89 AND 90

FOR THERMOCOUPLE  
Ø .25 5.0  
Ø .625 3.0  
(3.00)  
(2.00)

4X Ø1.0 THRU COOLING INLET / OUTLET TYP 2 PLCS

ALIGN WITH TEE HOLE NUMBER 18

Ø .25  
Ø .63  
1.00  
5.50

SEE DETAIL D

(1.00)

RELEASED FOR FABRICATION / INSTALLATION  
PPPL Drafting:

Oak Ridge National Laboratory managed for the DEPARTMENT OF ENERGY under U.S. GOVERNMENT contract DE-AC05-00OR22725 UT-BATTELLE, LLC. Oak Ridge, Tennessee									
PROJECT NAME NATIONAL COMPACT STELLARATOR EXPERIMENT									
PRODUCTION WINDING FORM TYPE-B									
VERSION NO. 2	PLANT X-10	BLDG 5700	FL 3	SHT OF 9	TYPE 12	CLASS S	REV U		
RELEASE LEVEL Fabrication		SE141-115					REV 9		

B SE141-115

A

FOR NOTES AND PARTS LIST SEE SHEET 1

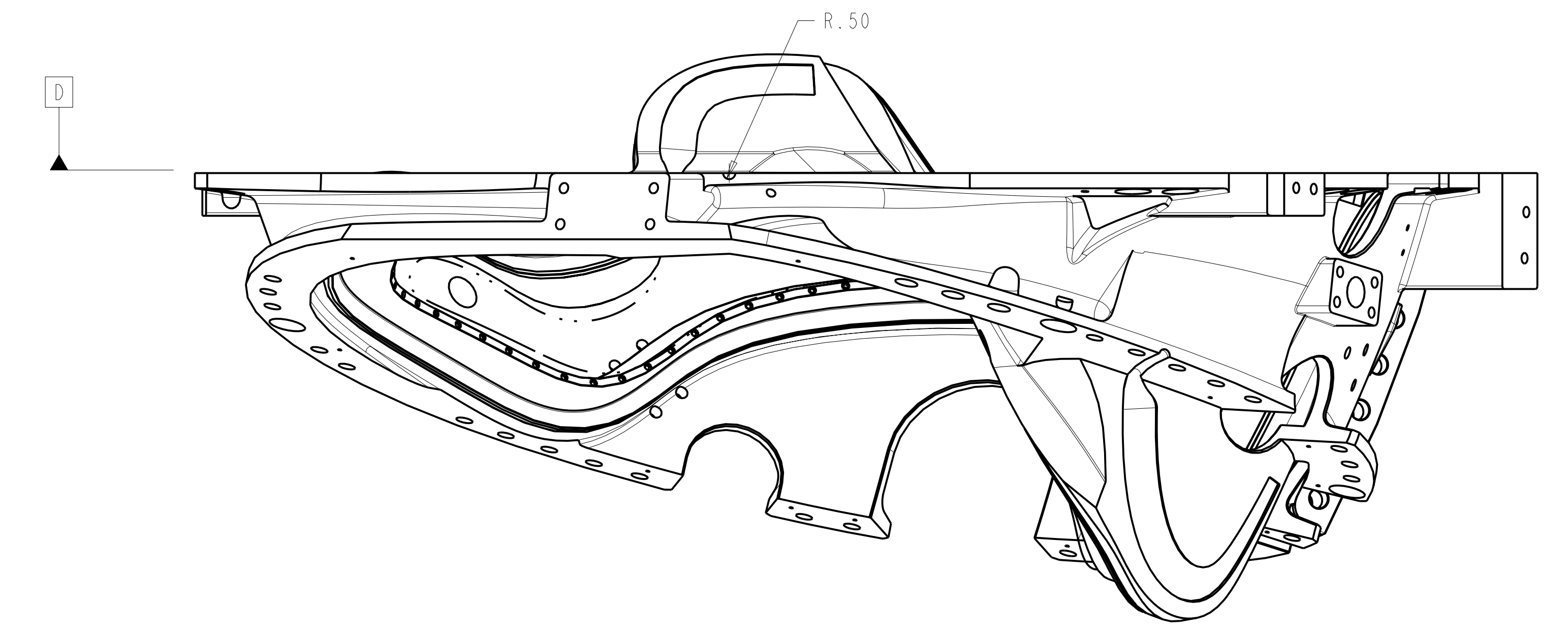
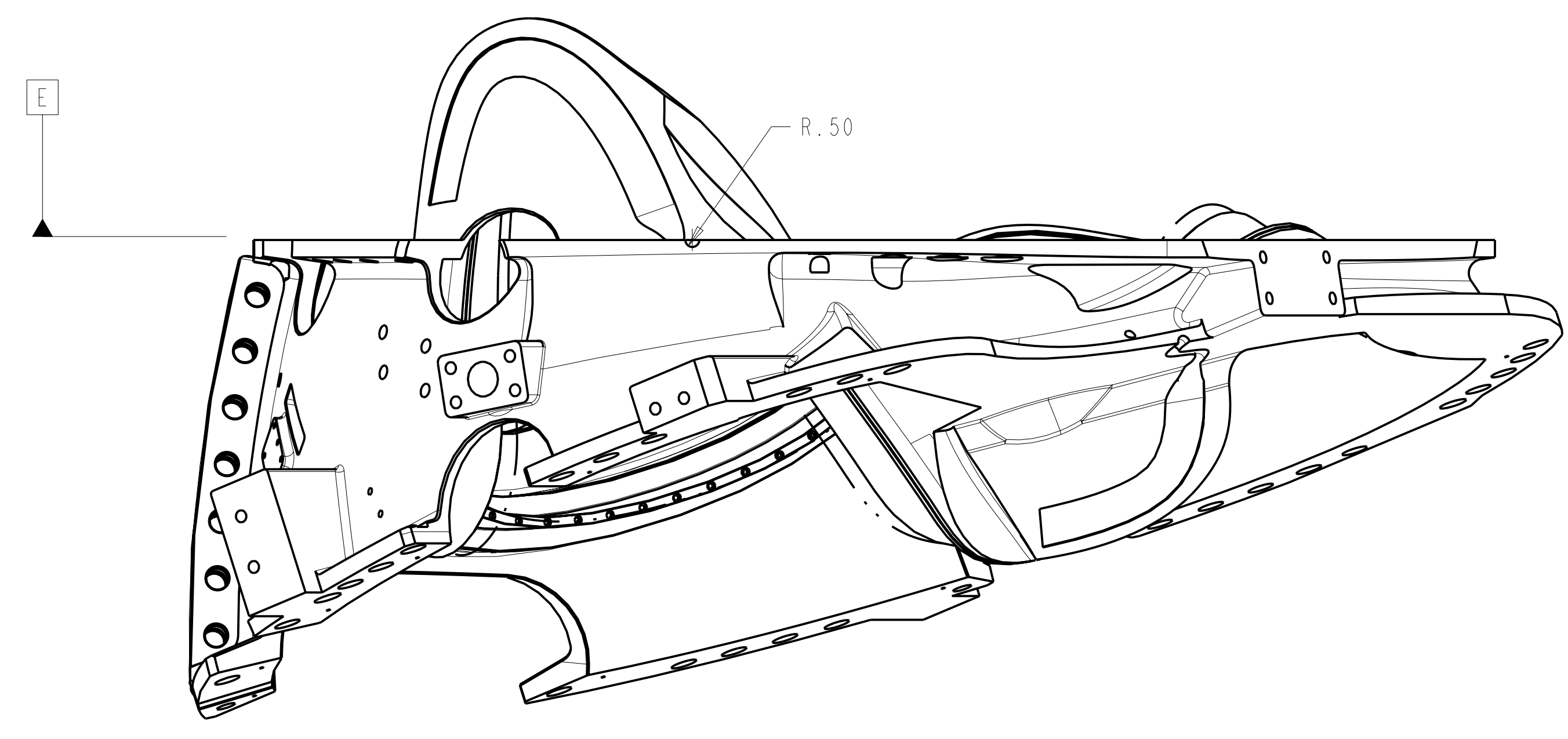
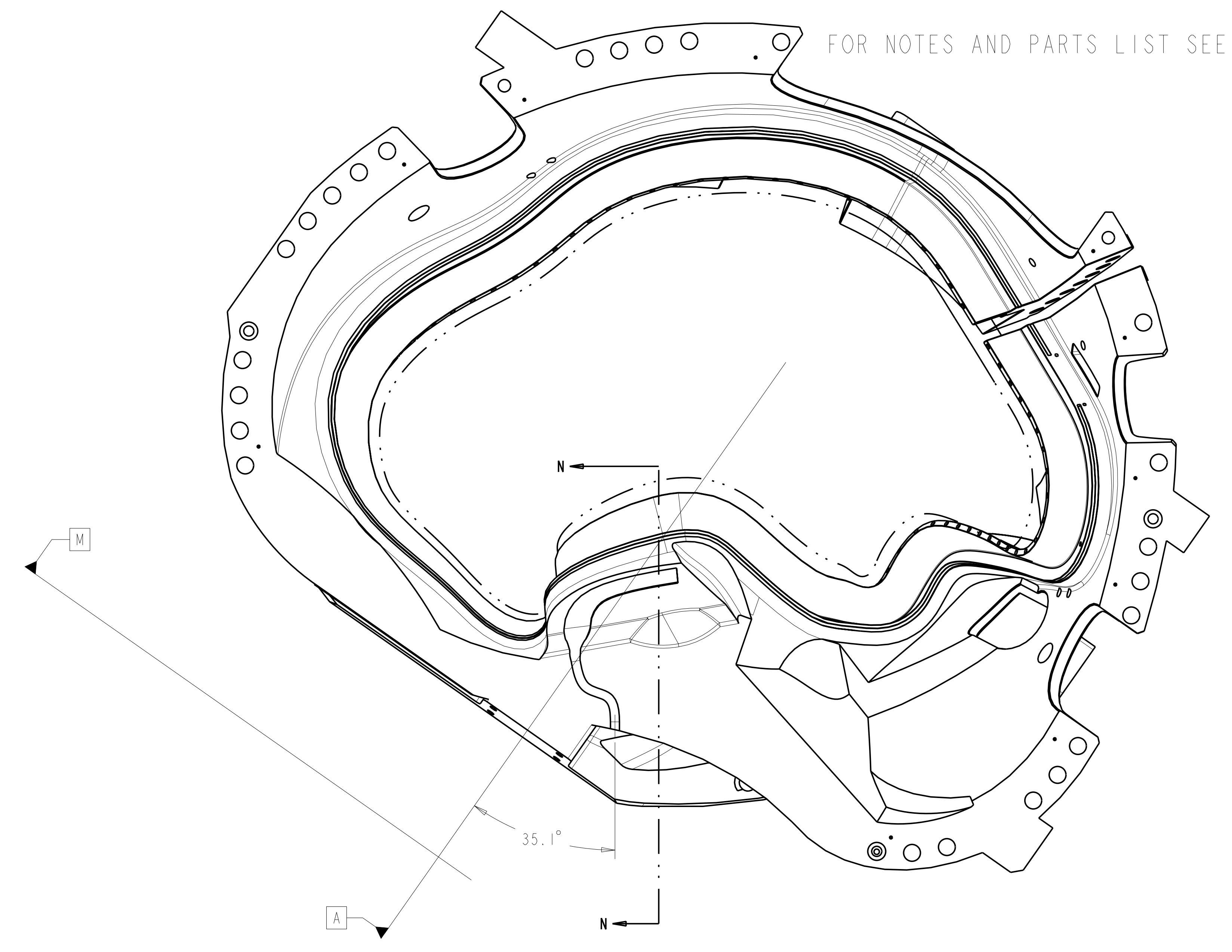
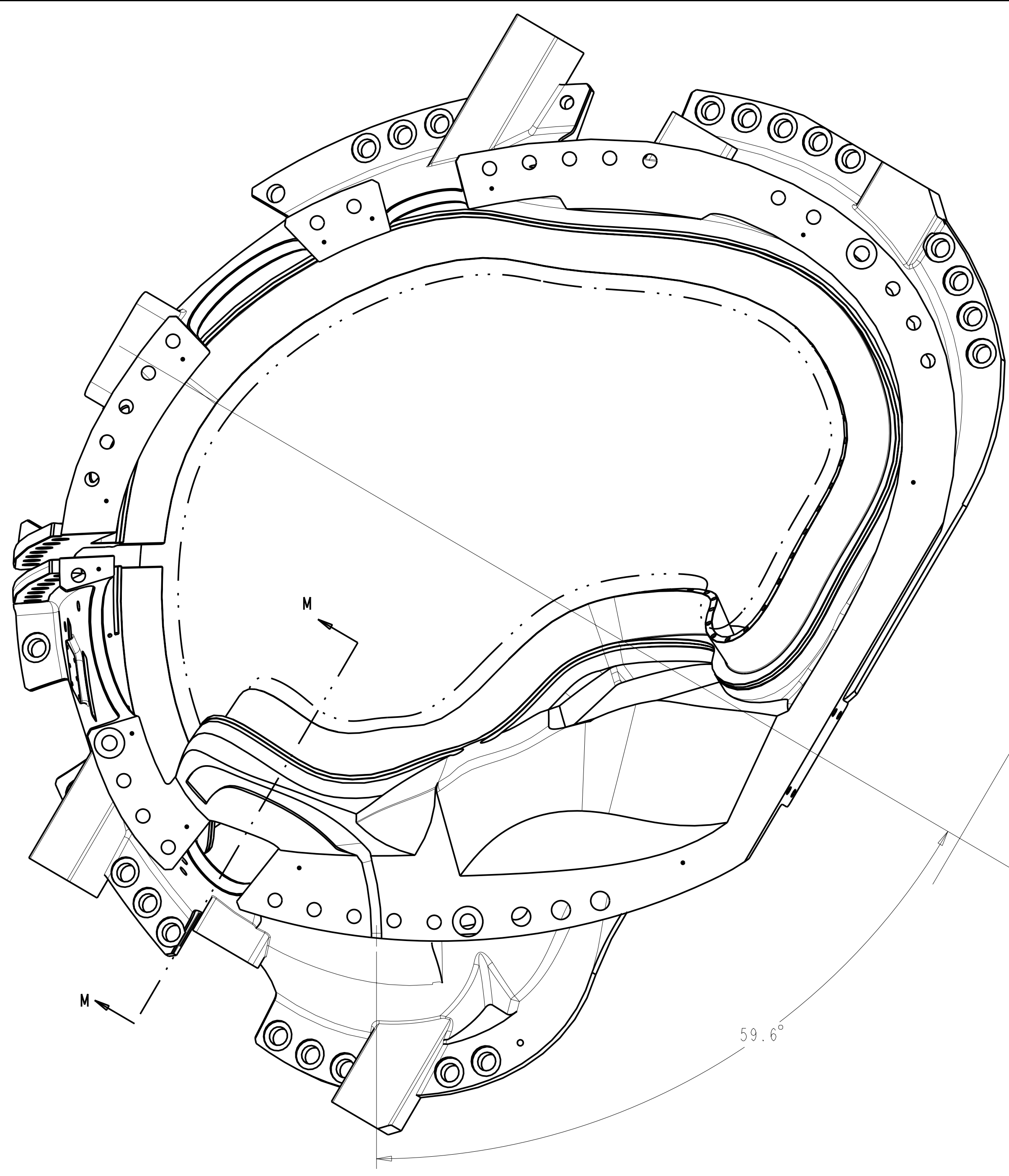

SCALE 0.125

SCALE 0.125

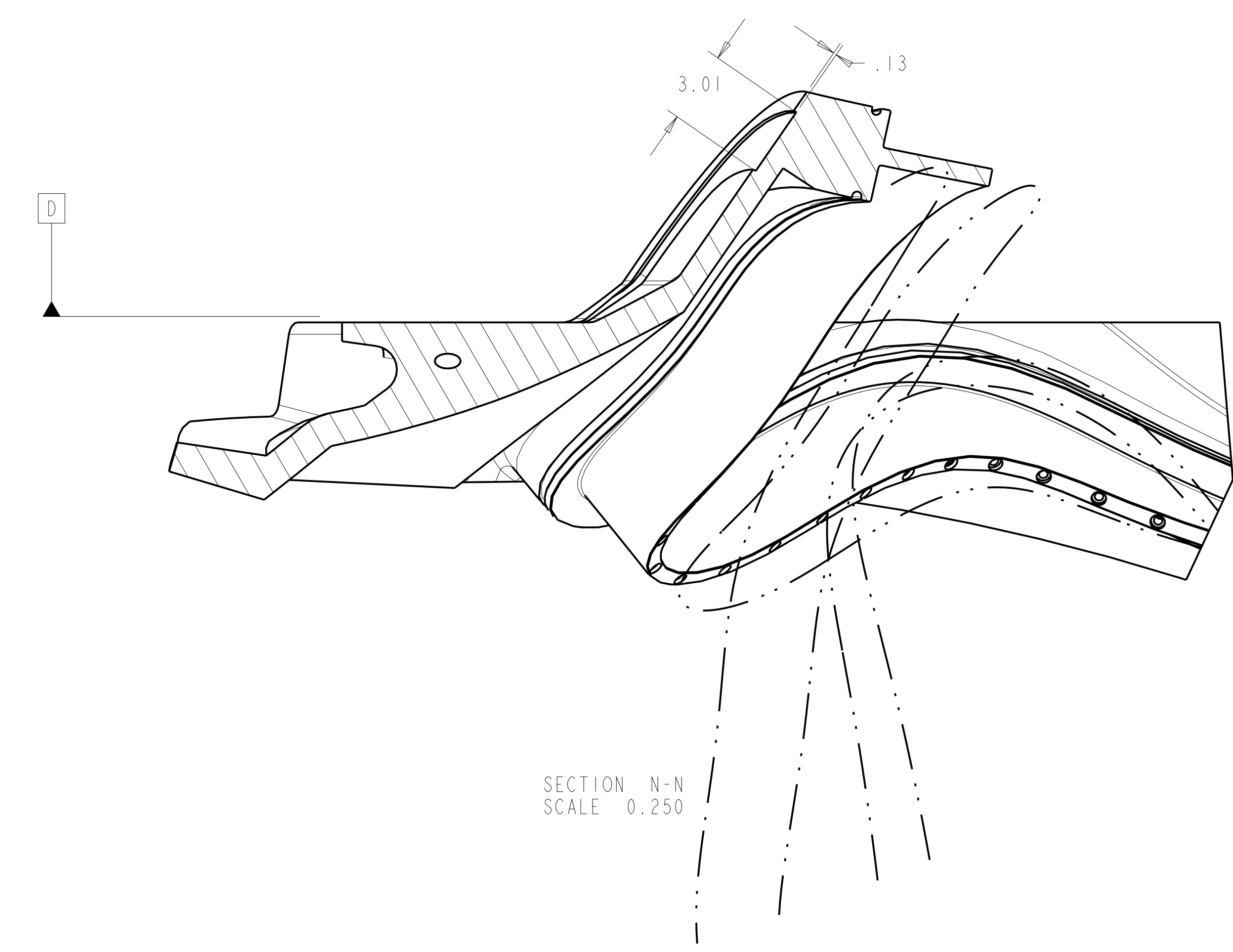
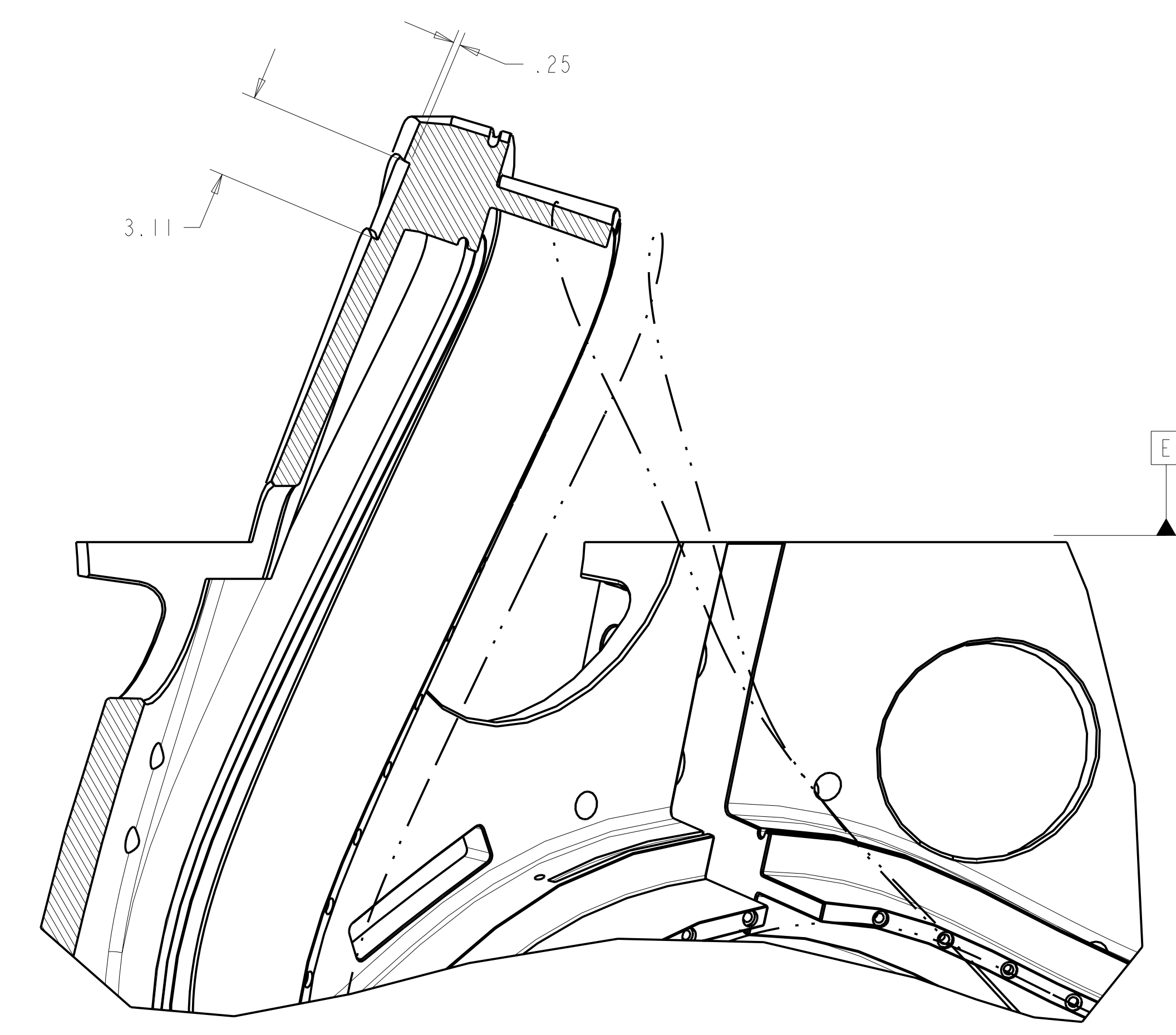

SECTION M-M  
SCALE 0.25

SECTION N-N  
SCALE 0.250

**RELEASED FOR  
FABRICATION / INSTALLATION**  
PPPL Drafting:

Oak Ridge National Laboratory managed for the DEPARTMENT OF ENERGY under <b>UT-BATTELLE</b> U.S. GOVERNMENT contract DE-AC05-00OR22725 UT-BATTELLE, LLC. Oak Ridge, Tennessee PROJECT NAME:									
<b>NATIONAL COMPACT STELLARATOR EXPERIMENT</b>									
<b>PRODUCTION WINDING FORM TYPE-B</b>									
VERSION NO.	PLANT	BLDG	FL	SHT	OF	TYPE	CLASS		
2	X-10	5700	3	10	12	S	U		
RELEASE LEVEL									
Fabrication		SE141-115							
								REV	9

SE141-115

A

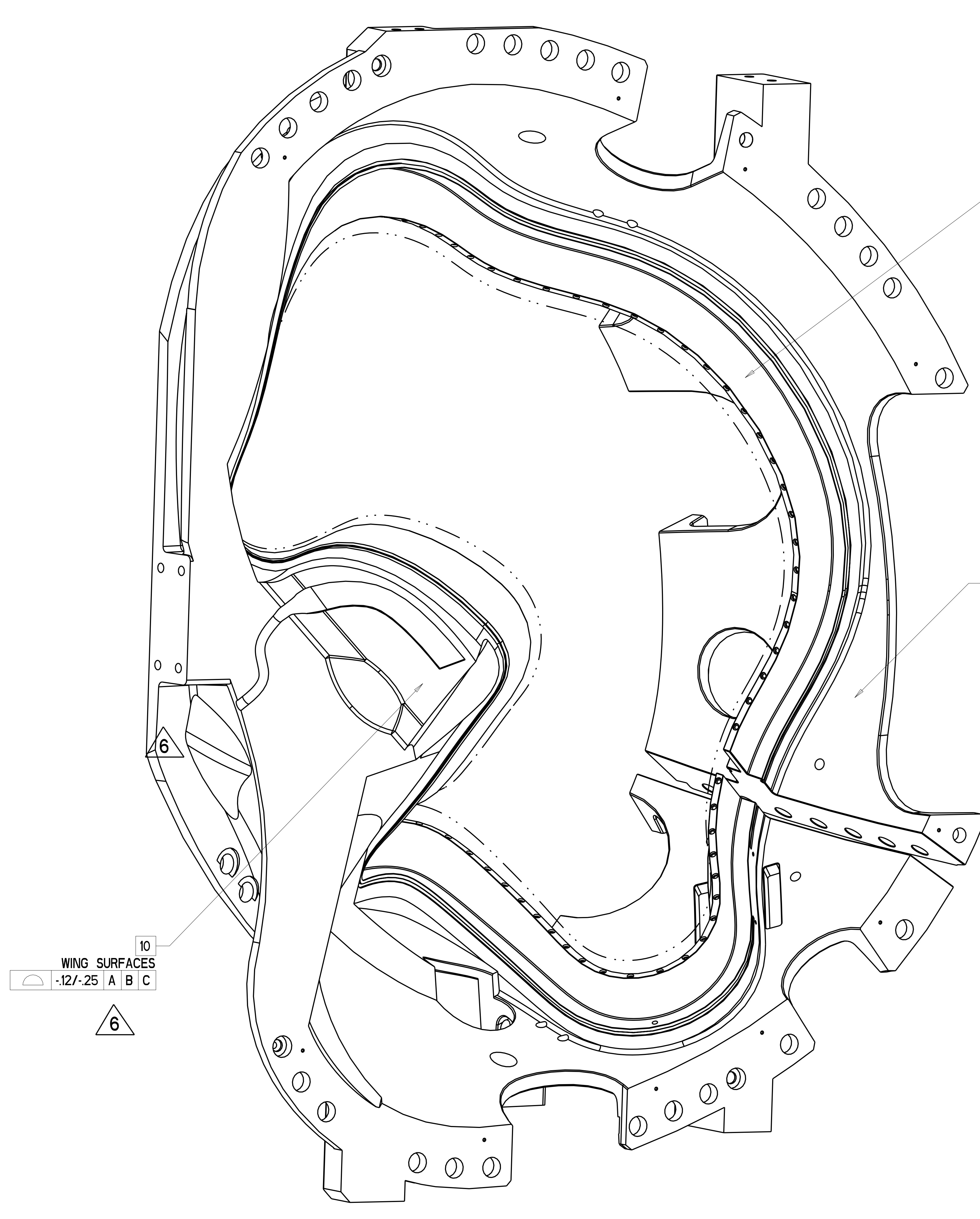

10  
WING SURFACES  
-.12/-25 A B C  
6

ISOMETRIC VIEW  
SCALE 0.20

MACHINED SURFACES  
.02 R T S

AS CAST SURFACES  
.5 A B C

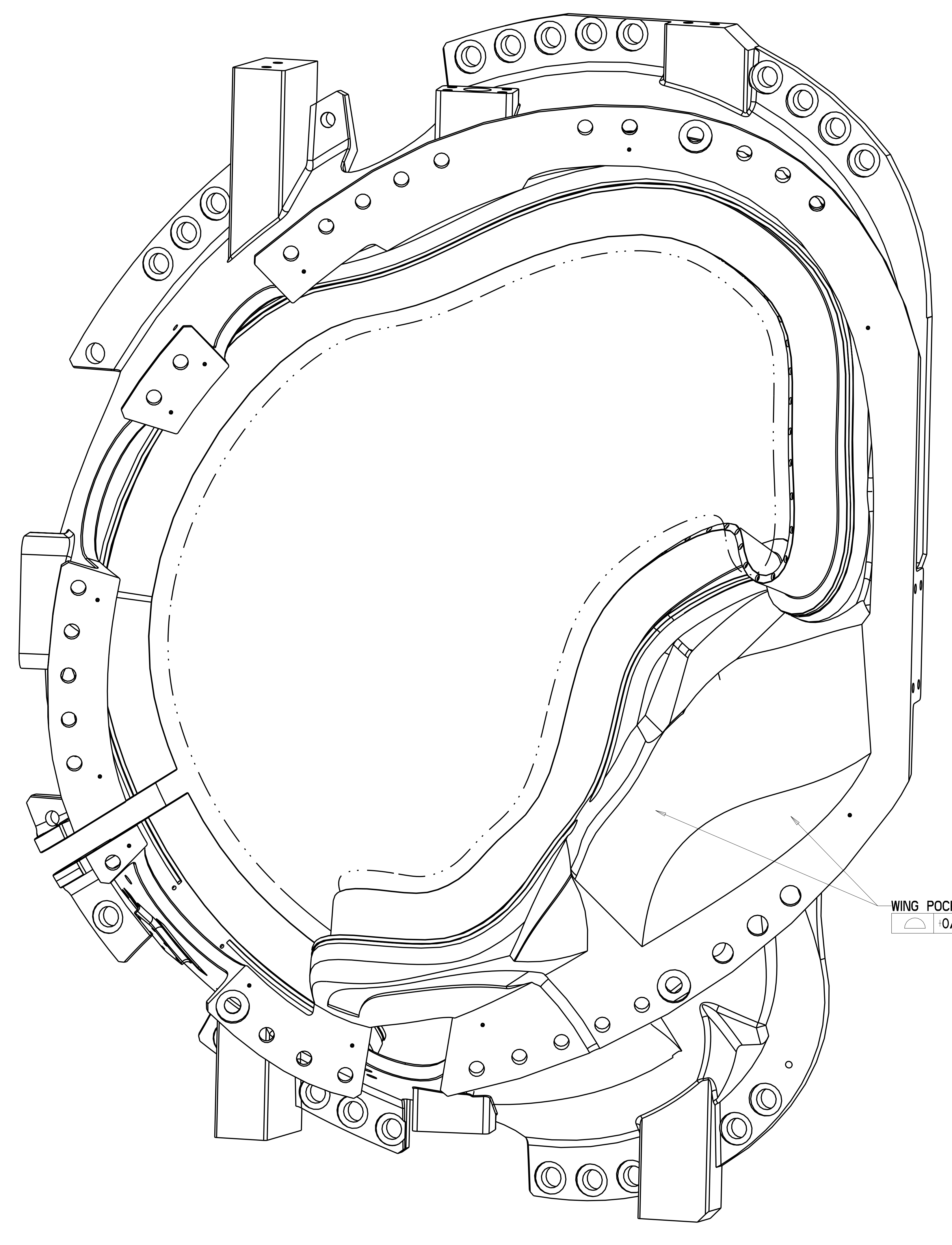

7  
WING POCKET  
-.10/-12 A B C

ISOMETRIC VIEW  
SCALE 0.20

**RELEASED FOR  
FABRICATION / INSTALLATION**  
PPPL Drafting:

Oak Ridge National Laboratory managed for the DEPARTMENT OF ENERGY under U.S. GOVERNMENT contract DE-AC05-00OR22725 UT-BATTELLE, LLC, Oak Ridge, Tennessee PROJECT NAME:									
<b>UT-BATTELLE</b> <b>NATIONAL COMPACT STELLARATOR EXPERIMENT</b>									
PRODUCTION WINDING FORM TYPE-B									
VERSION NO.	PLANT	BLDG	FL	SHT	OF	TYPE	CLASS		
2	X-10	5700	3	11	12	S	U		
RELEASE LEVEL		SE141-115						REV	
Fabrication								9	

TABLE I: WINDING CENTER SPLINE

#	X	Y	Z
1	79.865	41.620	0.000
2	79.954	40.848	2.703
3	79.699	40.139	5.412
4	79.119	39.497	8.088
5	78.246	38.924	10.700
6	77.117	38.408	13.224
7	75.763	37.938	15.645
8	74.211	37.508	17.951
9	72.480	37.112	20.134
10	70.577	36.765	22.177
11	68.497	36.500	24.052
12	66.238	36.363	25.721
13	63.807	36.404	27.133
14	61.235	36.672	28.237
15	58.581	37.144	29.040
16	55.889	37.663	29.673
17	53.175	37.978	30.340
18	50.507	37.834	31.201
19	48.064	37.012	32.306
20	46.021	35.540	33.546
21	44.254	33.716	34.757
22	42.521	31.789	35.851
23	40.699	29.859	36.784
24	38.758	27.959	37.516
25	36.704	26.097	37.991
26	34.572	24.269	38.127
27	32.429	22.476	37.826
28	30.386	20.727	37.012
29	28.588	19.001	35.716
30	27.114	17.255	34.077
31	25.883	15.587	32.178
32	24.821	14.306	29.918
33	23.992	13.709	27.307
34	23.371	13.765	24.568
35	22.818	14.265	21.857
36	22.202	15.020	19.217
37	21.441	15.899	16.655
38	20.621	16.692	14.084
39	20.049	17.171	11.376
40	20.161	17.234	8.581
41	21.328	16.913	6.069
42	23.531	16.306	4.490
43	26.144	15.366	4.287
44	28.434	13.980	5.112
45	30.309	12.246	6.288
46	32.355	10.489	7.039
47	34.864	9.267	6.901
48	37.491	8.707	6.095
49	40.022	8.663	4.876
50	42.401	8.965	3.406
51	44.570	9.536	1.713
52	46.320	10.429	-0.289
53	47.233	11.698	-2.606
54	47.125	13.289	-4.909
55	46.430	15.093	-6.949
56	45.523	16.965	-8.843
57	44.587	18.803	-10.758
58	43.702	20.655	-12.683
59	42.869	22.632	-14.502
60	42.101	24.779	-16.150
61	41.471	27.112	-17.589
62	40.952	29.625	-18.739
63	40.413	32.216	-19.696
64	39.799	34.789	-20.655
65	39.178	37.324	-21.706
66	38.712	39.872	-22.803
67	38.541	42.498	-23.793
68	38.682	45.210	-24.518
69	39.152	47.958	-24.854
70	40.574	50.339	-24.715
71	43.042	51.598	-24.560
72	45.773	51.353	-24.953
73	47.888	49.823	-25.946
74	49.488	47.833	-27.123
75	50.873	45.694	-28.316
76	52.175	43.493	-29.491
77	53.422	41.253	-30.650
78	54.602	38.966	-31.789
79	55.708	36.632	-32.905
80	56.771	34.262	-33.987
81	57.920	31.901	-34.998
82	59.424	29.677	-35.819
83	61.577	27.936	-36.187
84	64.224	27.142	-35.833
85	66.799	27.411	-34.786
86	68.891	28.519	-33.291
87	70.359	30.197	-31.589
88	71.208	32.226	-29.843
89	71.577	34.417	-28.120
90	71.705	36.624	-26.379
91	71.818	38.739	-24.527
92	72.074	40.660	-22.490
93	72.549	42.286	-20.247
94	73.227	43.552	-17.830
95	74.085	44.406	-15.294
96	75.150	44.757	-12.718
97	76.379	44.578	-10.198
98	77.604	44.014	-7.729
99	78.654	43.258	-5.232
100	79.425	42.436	-2.655
101	79.865	41.620	0.000

TABLE II: X-VECTOR SPLINE

#	X	Y	Z
1	76.869	38.919	0.000
2	76.879	38.207	2.540
3	76.554	37.557	5.076
4	75.918	36.974	7.570
5	75.009	36.455	9.992
6	73.864	35.985	12.323
7	72.514	35.557	14.550
8	70.983	35.164	16.663
9	69.285	34.807	18.652
10	67.421	34.509	20.496
11	65.384	34.313	22.162
12	63.176	34.265	23.605
13	60.816	34.419	24.772
14	58.351	34.791	25.634
15	55.837	35.283	26.272
16	53.297	35.688	26.862
17	50.760	35.772	27.577
18	48.340	35.330	28.511
19	46.224	34.244	29.638
20	44.431	32.703	30.807
21	42.733	30.999	31.896
22	40.967	29.285	32.847
23	39.081	27.609	33.622
24	37.068	25.992	34.164
25	34.953	24.432	34.383
26	32.801	22.930	34.140
27	30.767	21.481	33.304
28	29.043	20.013	31.956
29	27.630	18.525	30.298
30	26.399	17.345	28.296
31	25.477	17.058	25.859
32	24.819	17.452	23.336
33	24.189	18.162	20.874
34	23.470	19.015	18.482
35	22.654	19.874	16.123
36	21.896	20.556	13.690
37	21.443	20.938	11.122
38	21.683	20.928	8.512
39	23.068	20.450	6.363
40	25.381	19.653	5.489
41	27.755	18.609	5.886
42	29.770	17.269	6.925
43	31.505	15.672	8.110
44	33.234	13.933	9.079
45	35.335	12.402	9.436
46	37.740	11.379	9.131
47	40.202	10.829	8.372
48	42.607	10.658	7.303
49	44.893	10.789	5.995
50	46.968	11.229	4.430
51	48.653	12.022	2.569
52	49.833	13.010	0.431
53	50.424	14.109	-1.888
54	50.418	15.384	-4.194
55	49.943	16.903	-6.293
56	49.126	18.642	-8.101
57	48.239	20.382	-9.877
58	47.384	22.114	-11.677
59	46.581	23.935	-13.410
60	45.832	25.909	-14.994
61	45.189	28.058	-16.381
62	44.564	30.415	-17.385
63	43.870	32.858	-18.106
64	43.065	35.290	-18.742
65	42.181	37.688	-19.401
66	41.319	40.087	-20.090
67	40.643	42.558	-20.718
68	40.291	45.137	-21.140
69	40.312	47.768	-21.197
70	41.714	49.873	-20.816
71	44.203	50.628	-20.763
72	46.710	50.101	-21.266
73	48.649	48.613	-22.223
74	50.105	46.722	-23.344
75	51.310	44.671	-24.489
76	52.399	42.551	-25.624
77	53.420	40.389	-26.744
78	54.373	38.189	-27.848
79	55.254	35.948	-28.931
80	56.078	33.673	-29.987
81	56.920	31.386	-30.999
82	57.968	29.143	-31.910
83	59.522	27.125	-32.559
84	61.742	25.748	-32.658
85	64.255	25.402	-32.029
86	66.488	26.052	-30.819
87	68.167	27.386	-29.298
88	69.242	29.152	-27.668
89	69.782	31.158	-26.045
90	69.969	33.244	-24.440
91	70.030	35.297	-22.781
92	70.152	37.220	-20.979
93	70.459	38.907	-18.975
94	70.983	40.263	-16.775
95	71.696	41.227	-14.427
96	72.615	41.705	-12.005
97	73.726	41.632	-9.617
98	74.861	41.139	-7.287
99	75.826	40.441	-4.932
100	76.511	39.678	-2.501
101	76.869	38.919	0.000

ALL POINT LOCATIONS ARE BASIC

FOR NOTES AND PARTS LIST SEE SHEET I

**RELEASED FOR FABRICATION / INSTALLATION**  
PPPL Drafting:

Oak Ridge National Laboratory  
managed for the DEPARTMENT OF ENERGY under  
U.S. GOVERNMENT contract DE-AC05-00OR22725  
UT-BATTELLE, LLC. Oak Ridge, Tennessee  
PROJECT NAME

**NATIONAL COMPACT STELLARATOR EXPERIMENT**

PRODUCTION WINDING FORM TYPE-B

VERSION NO.	PLANT	BLDG	FL	SHT	OF	TYPE	CLASS	
2	X-10	5700	3	12	12	S	U	
RELEASE LEVEL		SE141-115					REV	9
Fabrication								