

Ø 2.216 MAXIMUM

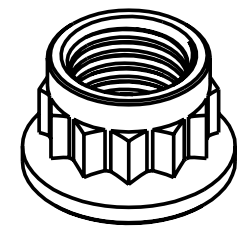
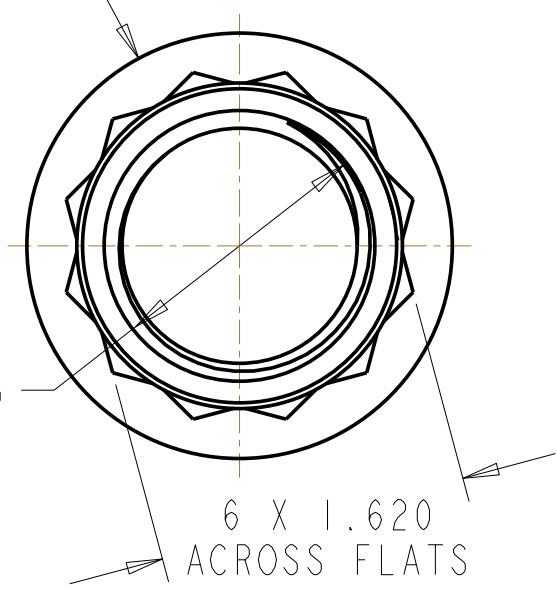

SCALE 0.500

1-3/8-6 UNC-2B

6 X 1.620
ACROSS FLATS

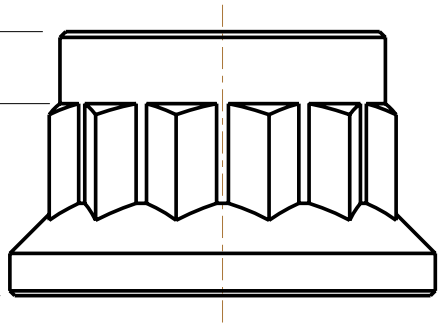
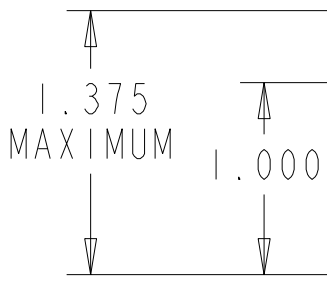

| | | | |
|------------|-------------------------------|--------|--|
| MATERIAL | ALLOY OR CARBON STEEL | SOURCE | BID / PREFERRED |
| SPEC | NA | VENDOR | SUGGESTED VENDOR: PCC SPS Fastener Division 301 HIGHLAND AVENUE JENKINTOWN, PA 19046 PHONE: 215-572-3000 |
| HEAT TREAT | NA | | |
| COATING | SILVER PLATE PER AMS 2410 | | |
| UNITS | INCHES | | |
| LUBRICANT | MOLYCOTE 321R PER MAN. INSTR. | | |

DATA SHEET

UT-BATTELLE
OAK RIDGE NATIONAL LABORATORY

| | | | | | | |
|-------------------------------|----------------------|--|-----------------------|----------|-------------|--|
| FILENAME DS141-060P | | TITLE / DESCRIPTION NUT, DOUBLE HEX, SELF LOCKING, 1-3/8-6 UNC-2B | | | | |
| PREPARED BY MT BROWN | CHECKED BY M COLE | APPROVED BY D WILLIAMSON | ISSUE DATE 6/24/04 | VER 2 | REV &rev | |