

Ø 1.450  
INSIDE  
DIAMETER

Ø 2.750  
OUTSIDE  
DIAMETER

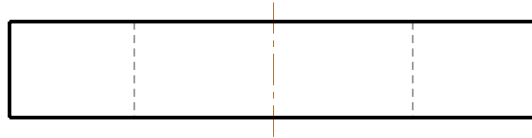
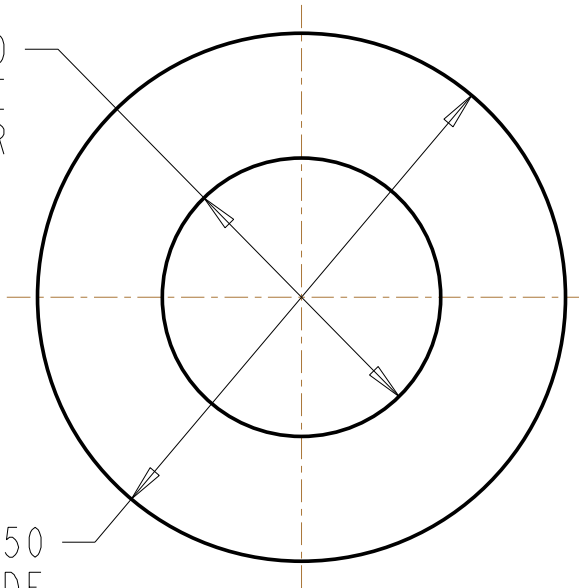

MATERIAL	ALLOY OR CARBON STEEL	SOURCE	BID / PREFERRED
SPEC	NA	VENDOR	COMPANY ADDRESS PHONE
HEAT TREAT	NA		
COATING	SILVER PLATE PER AMS 2411		
UNITS	INCHES		
	REMOVE ALL BURRS & SHARP EDGES		

DATA SHEET



FILENAME	TITLE / DESCRIPTION				
<b>DS141-079P</b>	0.125 THICK FLAT WASHER				
PREPARED BY	CHECKED BY	APPROVED BY	ISSUE DATE	VER	REV
MT BROWN	M COLE	D WILLIAMSON	6/24/04	2	&rev