

- NOTES:
1. INTERPRET DIMENSIONS AND TOLERANCES PER ANSI Y14.5M
 2. DIMENSIONS ARE IN INCHES
 3. DIMENSIONS APPLY AT TEMPERATURE OF 20-30°C (68-86°F)
 4. DRAWING DEPICTS FINAL MACHINED STATE OF ASSEMBLY DEFINED BY PRO/ENGINEER FILE SE141-058.ASM
 5. APPROXIMATE WEIGHT=120 LBS
 6. SEE LATEST REVISION OF SPECIFICATION NCSX-CSPEC-141-03 FOR ADDITIONAL REQUIREMENTS
 7. BOND INSULATING SLEEVE (ITEM 3) INTO SHIM (ITEM 2) USING LOCTITE 411 PER MANUFACTURER'S INSTRUCTIONS
 8. SHIM MATERIAL FROM SAME CASTING AS PART SE141-115; MARK FOR IDENTIFICATION

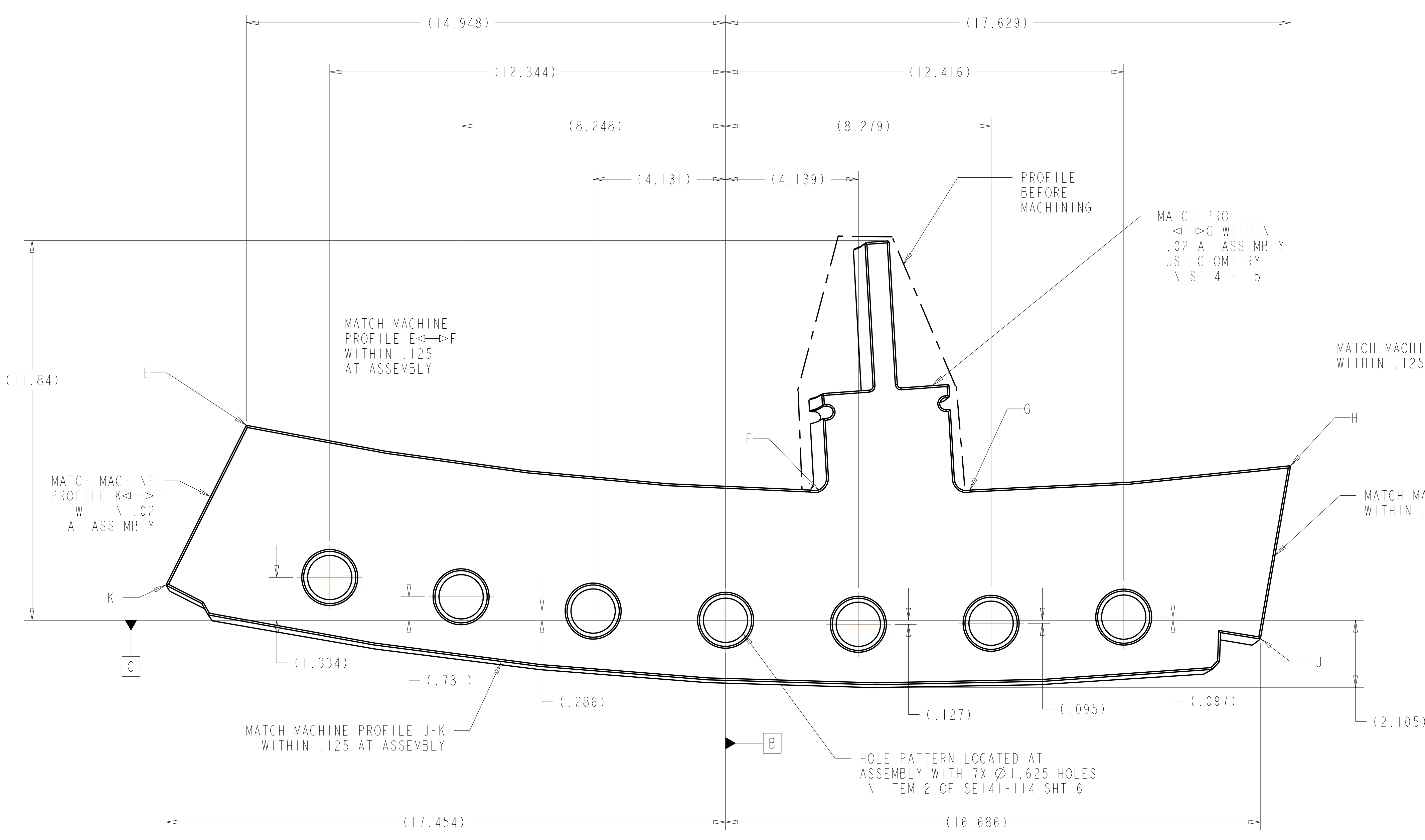

Rev 2-a: RFD 14-019 added lifting holes - See RFD-14-019 for details. Applicable to C6 and all Type A and B Castings

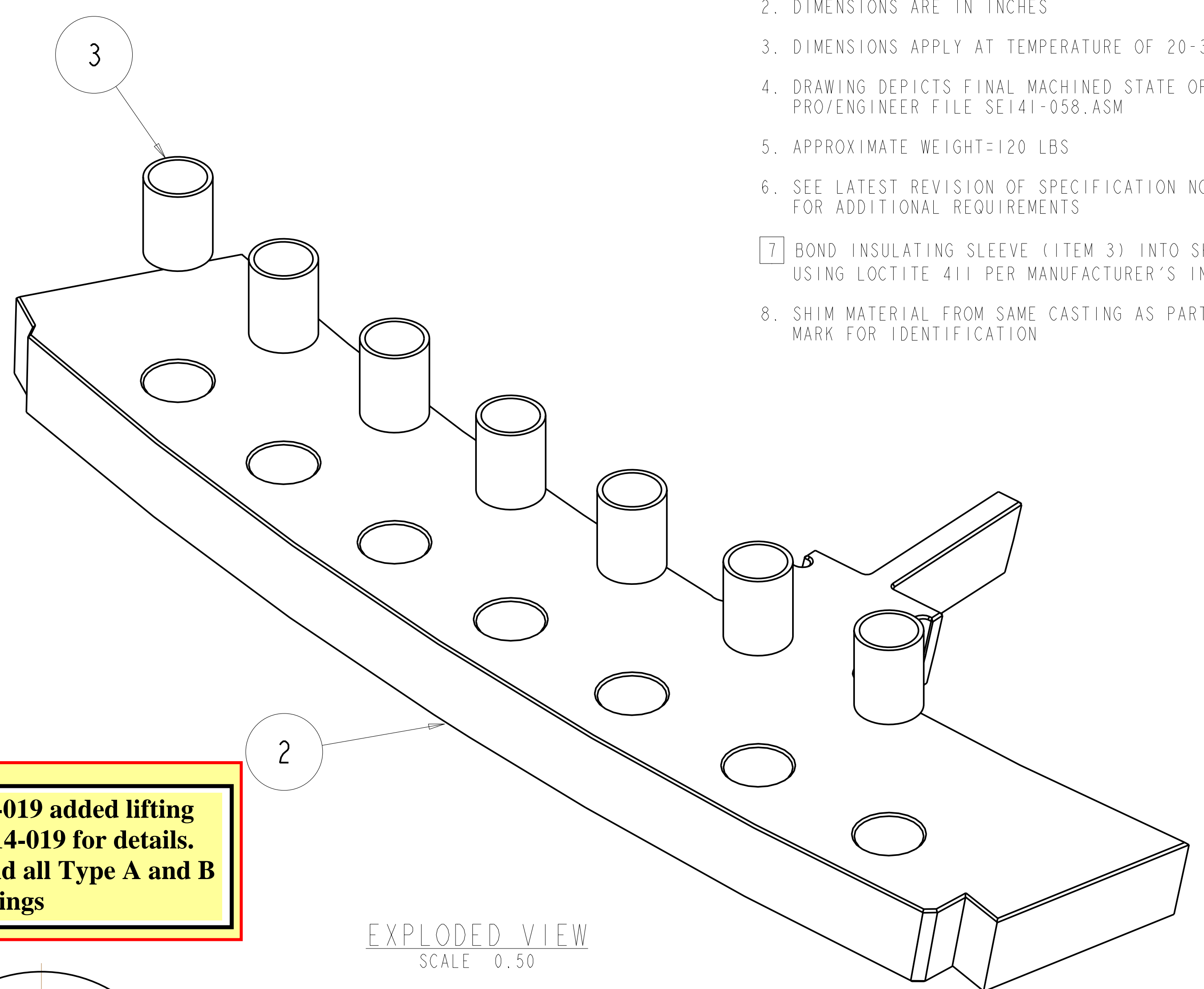

EXPLODED VIEW
SCALE 0.50

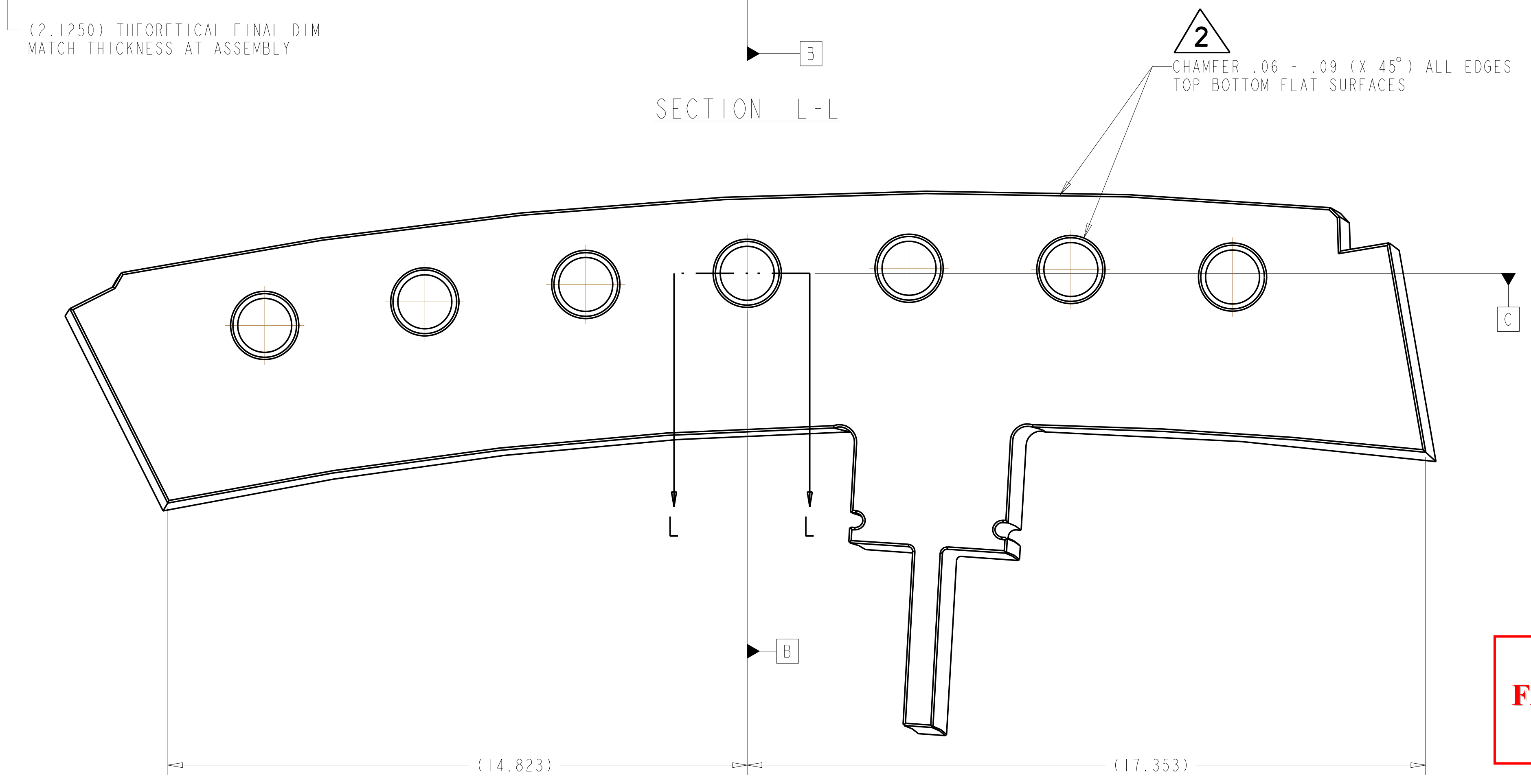
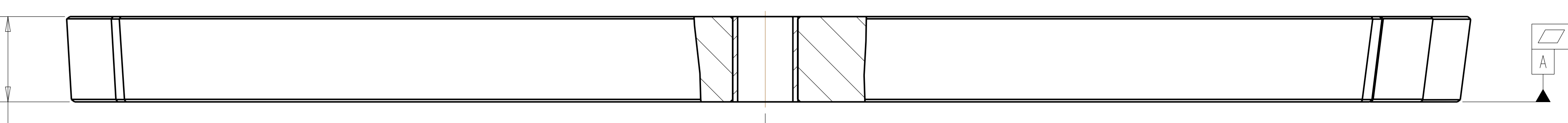
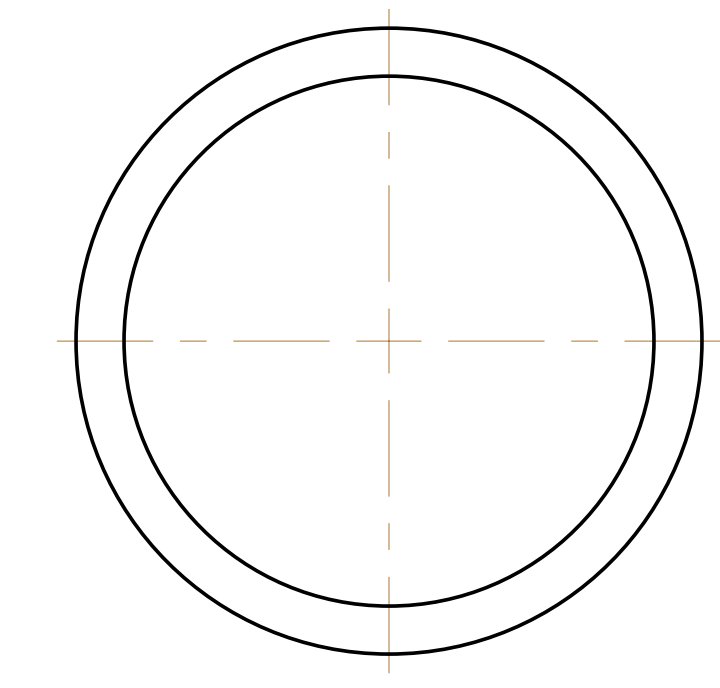

SECTION L-L

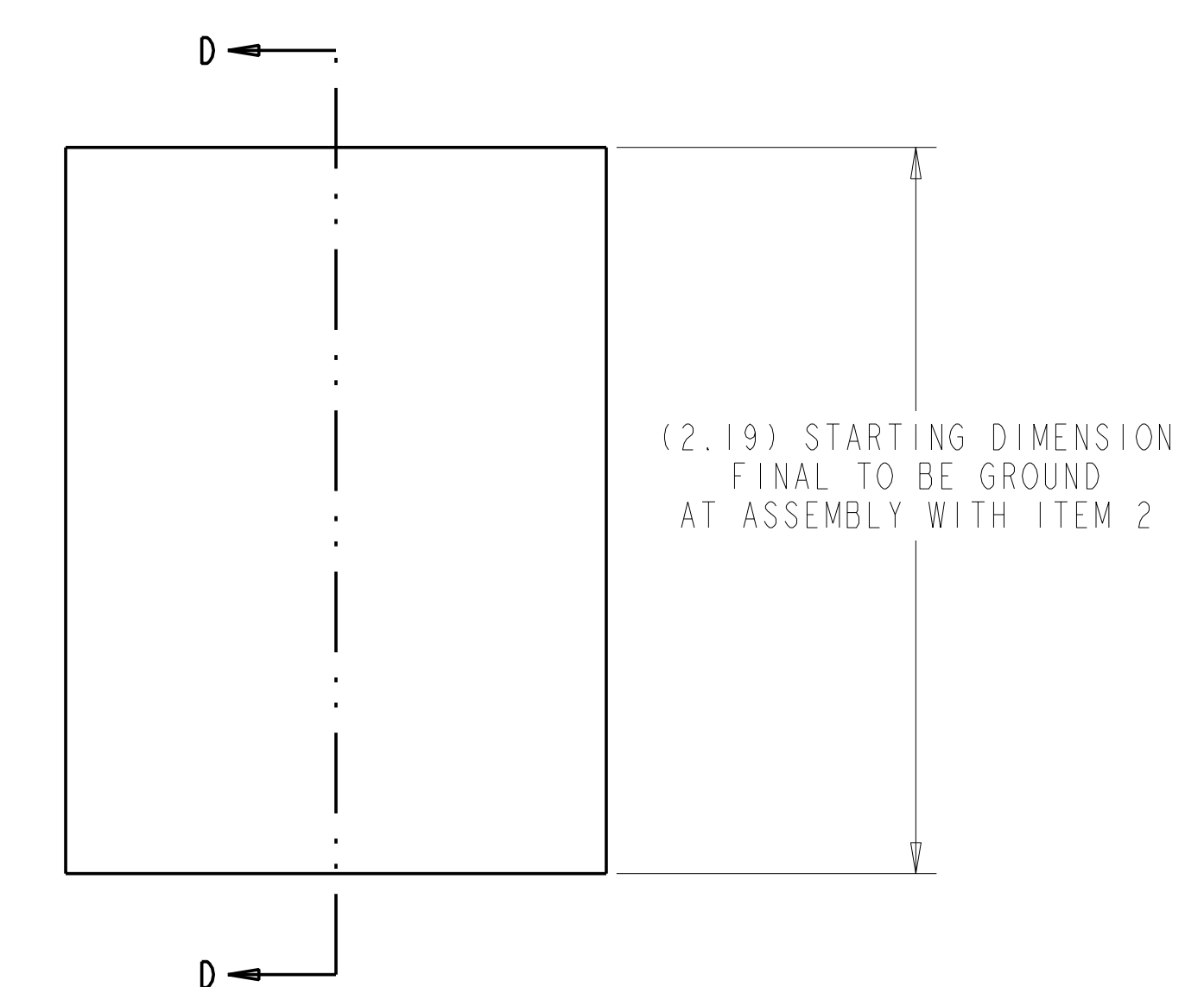

Ø 1.63 OD TO MATCH HOLE DIA MINUS .001 TO .002 FOR CLEARANCE FIT

SECTION D-D
SCALE 2.00

RELEASED FOR FABRICATION / INSTALLATION
PPPL Drafting:

REV	DESCRIPTION	BY	DATE	CHK	DEPT	PE	REQ	DATE	ORNL	DOE	DATE
2	REVISE PART AND DRW PER ECN 5059	GLL	12/03	MJC		DEW					
1	REVISED "T" PROFILE PER ECN-4903	GLL	8/04	MJC		DEW					

REV	DESCRIPTION	BY	DATE	CHK	DEPT	PE	REQ	DATE	ORNL	DOE	DATE
2	REVISE PART AND DRW PER ECN 5059	GLL	12/03	MJC		DEW					
1	REVISED "T" PROFILE PER ECN-4903	GLL	8/04	MJC		DEW					

CAGE CODE	PART OR IDENTIFYING NO	NOMENCLATURE OR DESCRIPTION	MATERIAL	SPECIFICATION	FIND NO
7	-3	SHIM INSULATING SLEEVE ALL TYPES	GIICR	NEMA LI 1 - 1998	3
I	-2	POLOIDAL BREAK SHIM TYPE-B	NOTE 8	--	2
AR	X	-1	POL BREAK SHIM ASSEMBLY TYPE-B		
201-11435					

NO REPRESENTATION OR WARRANTY, EXPRESSED OR IMPLIED, IS MADE AS TO THE ACCURACY, COMPLETENESS OR USEFULNESS OF THE INFORMATION OR STATEMENTS CONTAINED IN THESE DRAWINGS, OR THAT THE USE OR DISCLOSURE OF ANY INFORMATION, APPARATUS, METHOD OR PROCESS DISCLOSED IN THESE DRAWINGS MAY NOT INFRINGE PRIVATE RIGHTS OF OTHERS. NO LIABILITY IS ASSUMED WITH RESPECT TO THE USE OF, OR FOR DAMAGES RESULTING FROM THE USE OF, ANY INFORMATION, APPARATUS, METHOD OR PROCESS DISCLOSED IN THESE DRAWINGS. DRAWINGS MADE AVAILABLE FOR INFORMATION TO BIDDER ARE NOT TO BE USED FOR OTHER PURPOSES, AND ARE TO BE RETURNED UPON REQUEST OF THE FORWARDING CONTRACTOR.

P THIS DRAWING PRODUCED ON PRO-ENGINEER

REVISION OR ISSUE PURPOSE	REVISION APPROVAL
2 REVISE PART AND DRW PER ECN 5059	GLL 12/03 MJC DEW
1 REVISED "T" PROFILE PER ECN-4903	GLL 8/04 MJC DEW

SCALE NOTED	DESIGNER	DATE
TOLERANCES UNLESS OTHERWISE SPECIFIED	T BROWN	6-30-04
FRACTIONS ±.01	DRW PAUL MILLER	6-30-04
XX DECIMALS ±.005	CHK M COLE	6-30-04
XXX DECIMALS ±0.0015	SECT :	
ANGLES ±0°15'	DEPT :	
BREAK SHARP EDGES 06 MAX	PE D WILLIAMSON	6-30-04
FINISH .125 UNLESS OTHERWISE SPECIFIED	CR :	
	PJ :	
	RED :	
	PPPL DRFT J STEGEL	6-30-04
	DATE :	

VERSION NO.	PLANT	BLDG	FL	SHT OF	TYPE	CLASS
2	X-10	5700	3	1	I	S U
RELEASE LEVEL						
Fabrication						
SEI41-058						
REV 2						

SEI41-058

A