

DETAIL A  
SCALE 0.400

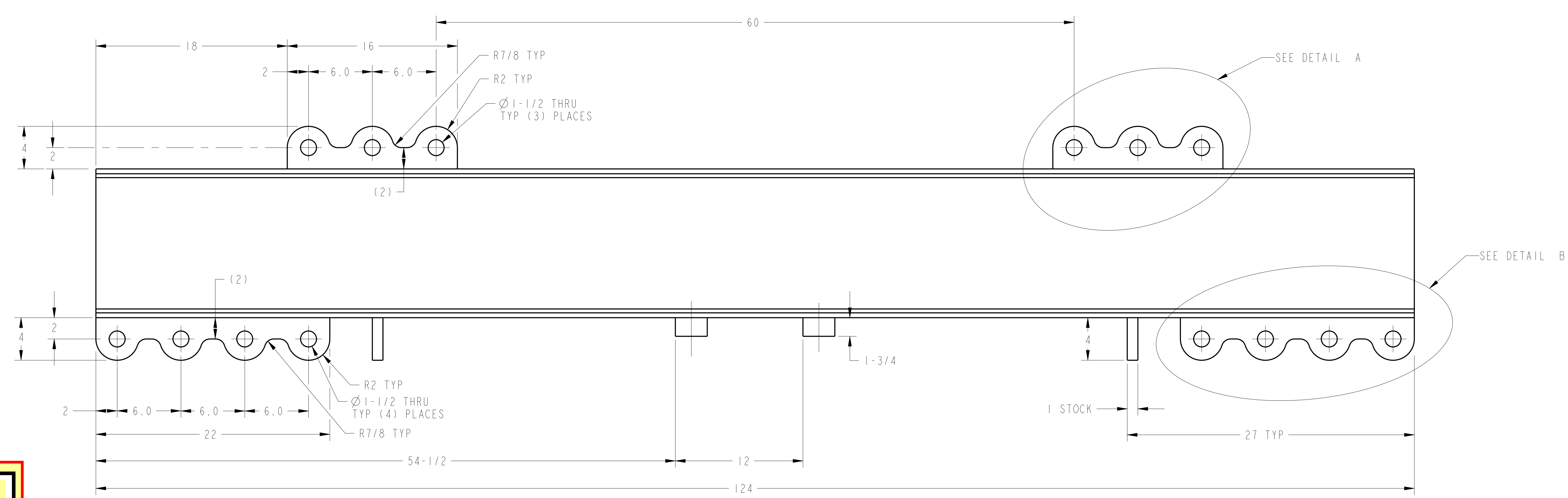

**RFD-18-004 replaced either "GMAW or GTAW" welds with either "GMAW or FCAW" welds wherever appearing on this drawing. See RFD-18-004 for details)**

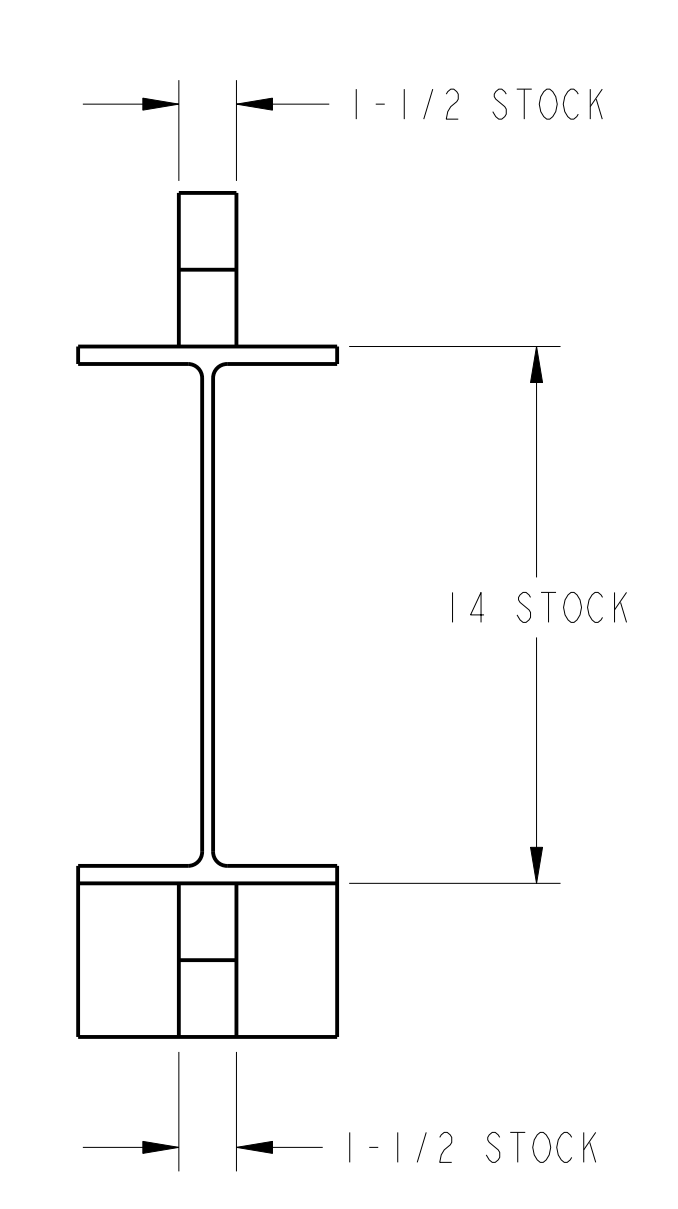
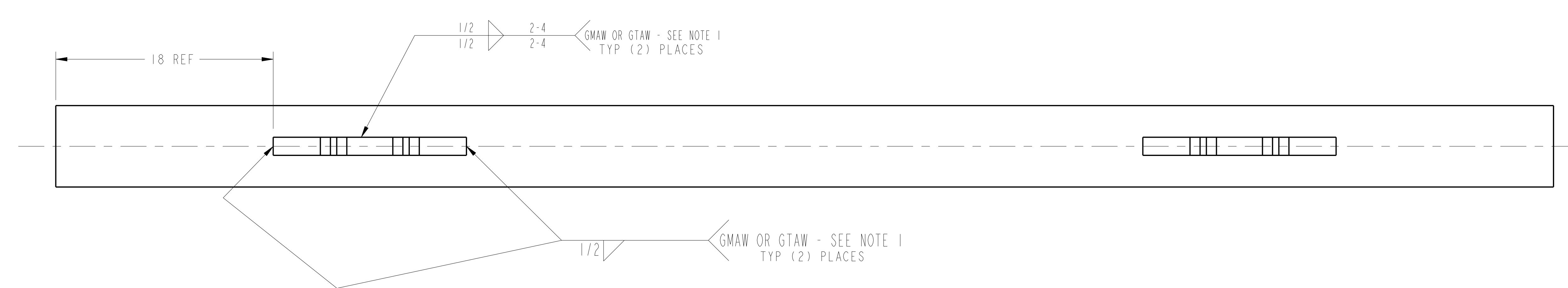
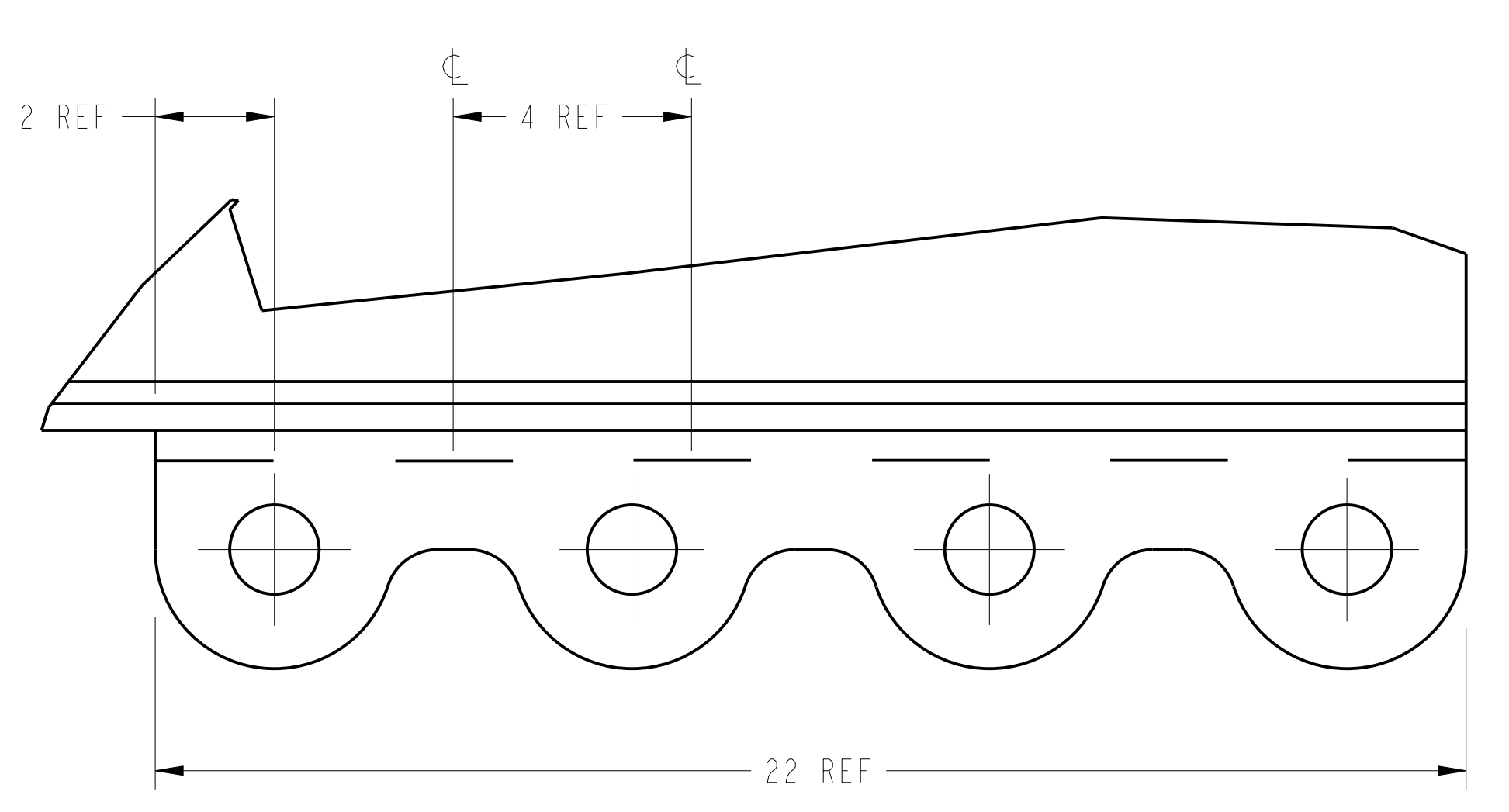
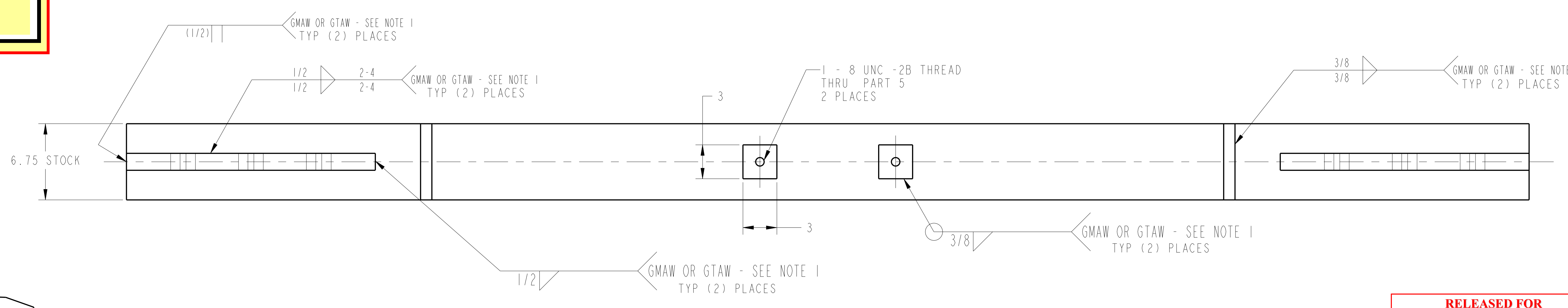

DETAIL B  
SCALE 0.400

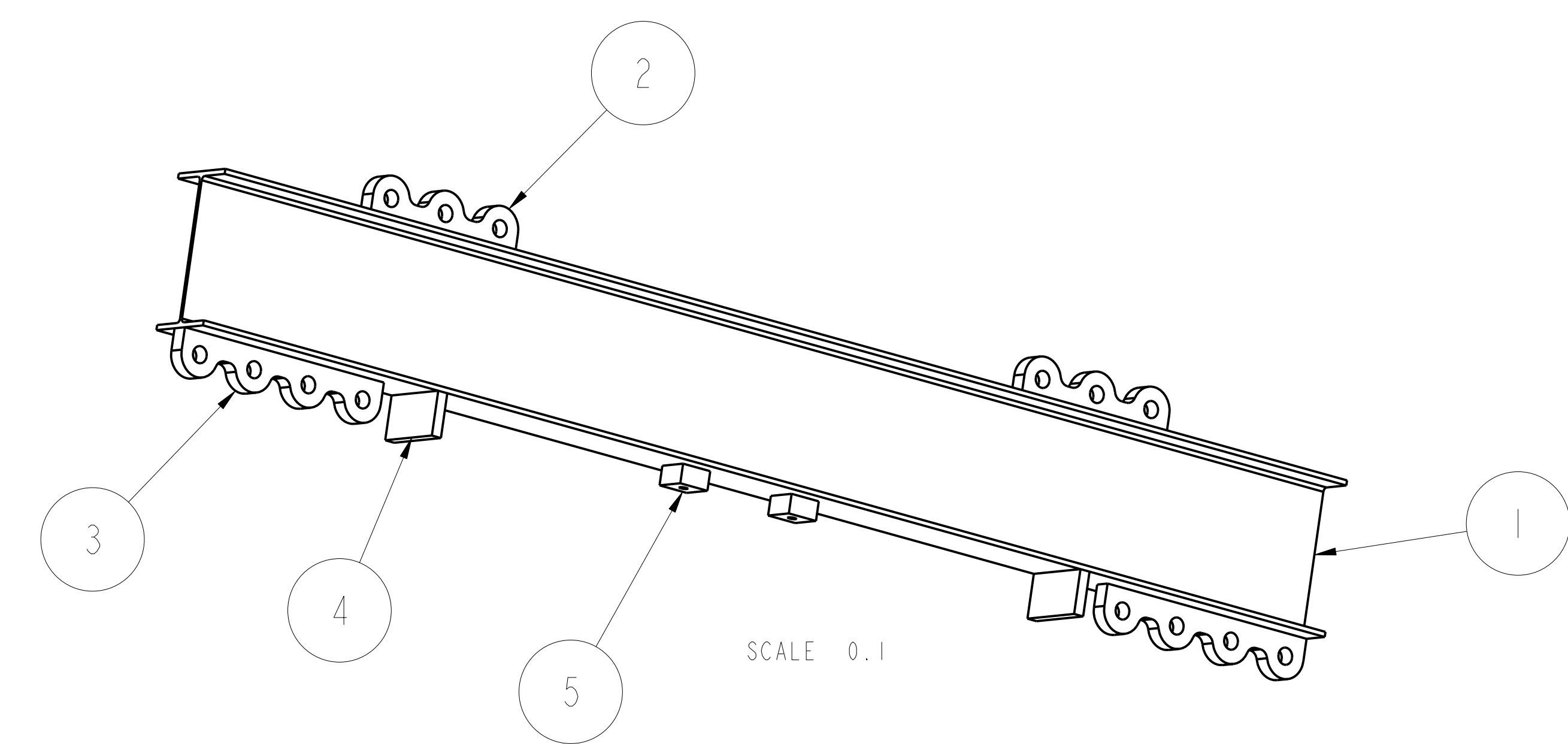

SCALE 0.1

**RELEASED FOR FABRICATION / INSTALLATION**  
PPPL Drafting

**NOTES**  
1. WELDING SHALL BE PERFORMED IN ACCORDANCE WITH THE REQUIREMENTS OF AWS D14.1 OR PPPL PROCEDURE ENG-037. VISUAL WELD INSPECTION SHALL BE PERFORMED IN ACCORDANCE WITH THE ACCEPTANCE CRITERIA OF AWS D1.1 Section 6.

PART NO.	DRAWING NO	NOMENCLATURE OR DESCRIPTION	MATERIAL	QTY REOD
5	SE186-360-5	MOUNT BLOCK	36,000 ksi STEEL	2
4	SE186-360-4	FLOOR SUPPORT	36,000 ksi STEEL	2
3	SE186-360-3	LOWER LIFT LUG	36,000 ksi STEEL	2
2	SE186-360-2	UPPER LIFT LUG	36,000 ksi STEEL	2
1	SE186-360-1	LIFTING BEAM - W14 x 34#	36,000 ksi STEEL	1

**PARTS LIST**

COMPUTER GENERATED DRAWING MANUAL CHANGES NOT PERMITTED Pro E DO NOT VERIFY INFORMATION BY SCALING DRAWING	CENTRAL FILES: UNLESS OTHERWISE SPECIFIED DIMENSIONS ARE IN INCHES MACHINE SURFACES BREAK SHARP EDGES .005/.020	PRINCETON PLASMA PHYSICS LABORATORY PRINCETON, UNIVERSITY, TX <b>NATIONAL COMPACT STELLATORATOR EXPERIMENT</b> TOOLING DESIGN AND FABRICATION FIELD PERIOD ASSEMBLY FIXTURE MODULAR COIL LIFTING BEAM WELDMENT
TOLERANCES NON-CUMULATIVE DECIMAL-INCH FRACTIONS: .XX ±.005 .XXX ±.005 ANGULAR ±.05°	DSN: R. UPCAVALA 2/26/2008 CHK: M. VIOLA 2/26/2008 ENGR: B. SANDS 2/26/2008 SUPV: J. SIEGEL 2/26/2008	DRAWING NO: <b>SE186-360</b> SHEET 1 OF 1 REV 0

RELEASE LEVEL: Fabrication  
DWG VERSION NO: 2

WEIGHT 416 lbs	MODEL NAME SE186-360	WELDING ENGINEER L. DUDEK 2/26/2008
-------------------	-------------------------	--

NCSX-SE186-360