

# NCSX

## Field Period Assembly Station 1 Dimensional Control Plan

NCSX-PLAN-FPA1DC-00

February 1, 2006

Author: \_\_\_\_\_  
Brent Stratton- Dimensional Control Coordinator

Reviewed By: \_\_\_\_\_  
Steve Raftopoulos- Metrology Engineer

Reviewed By: \_\_\_\_\_  
Tom Brown- NCSX WBS 18 Manager (Field Period Assembly)

Reviewed By: \_\_\_\_\_  
Mike Viola-Field Period Assembly Facility Manager

Reviewed By: \_\_\_\_\_  
George Labik- Diagnostics Engineer

Reviewed By: \_\_\_\_\_  
Paul Goranson- WBS 11 Manager (Vacuum Vessel)

Reviewed By: \_\_\_\_\_  
Dave Johnson- WBS 3 Manager (Diagnostics)

Reviewed By: \_\_\_\_\_  
Mike Zarnstorff- Head of Research Preparation

Reviewed By: \_\_\_\_\_  
Brad Nelson- Project Engineer for Stellarator Systems  
(WBS 1) Manager

Approved By: \_\_\_\_\_  
Larry Dudek – Stellarator Core On-Site Fabrication RLM

Controlled Document  
**THIS IS AN UNCONTROLLED DOCUMENT ONCE PRINTED.**  
Check the NCSX Engineering Web prior to use to assure that this document is current.

**Field Period Assembly Station 1 Dimensional Control Plan  
NCSX-PLAN-FPA1DC-00**

**RECORD OF CHANGE**

Revision	Date	Description of Change
00	12/1/2006	Initial release

**TABLE OF CONTENTS**

<b>1</b>	<b>Introduction and Scope.....</b>	<b>1</b>
1.1	Introduction	1
1.2	Scope	1
<b>2</b>	<b>Field Period Assembly Station 1 Dimensional Control Steps .....</b>	<b>3</b>

**List of Figures**

Figure 1-1 Flux Loop Layout on NCSX .....	2
Figure 1-2 Flux Loops, H/C Tubes, and Flux Loop Lead Layout .....	3
Figure 2-1 VVSA Mounted on VV Prep Fixture in +60° Position.....	4
Figure 2-2 VVSA Fiducials on Parting Plane Flanges and Neutral Beam Flange .....	5
Figure 2-3 Flux Loop Template Showing Designation, Orientation Arrow, and Fiducial Marks .....	6
Figure 2-4 Location of Notches and Direction Arrows .....	7

**Field Period Assembly Station 1 Dimensional Control Plan**  
**NCSX-PLAN-FPA1DC-00**

## **1 Introduction and Scope**

### **1.1 Introduction**

This plan describes the dimensional control steps required for Station 1 of NCSX Field Period Assembly (Vacuum Vessel Prep). This includes: initial inspection of the Vacuum Vessel Subassembly (VVSA), marking the locations of the flux loops and heating/cooling tube clamps, installation of the flux loops and routing of the leads, installation of the H/C tubes, and termination of the flux loops. The flux loops are fabricated from 1/16" diameter mineral-insulated cable mounted directly on the surface of the VVSA. The H/C tubes are not mounted directly on the VVSA surface; they are mounted on supports held to the VVSA with studs. A 1/8" clearance will be maintained between the H/C tubes and the VVSA surface to provide clearance for the flux loops. The flux loop leads are twisted and run on the surface of the VVSA to termination boxes located near the flanges of the large vertical ports.

There are three Field Period Assemblies (FPAs). Figure 1-1 shows the final layout of the flux loops on the three field periods plotted in phi (toroidal angle)-theta (poloidal angle) coordinates. FPA 1 will have 65 flux loops, FPA 2 will have 80 flux loops, and FPA 3 will have 67 flux loops. There will also be four toroidal voltage loops mounted on the surface of the VVSA (not shown in figure 1-1), 16 flux loops on one of the three vacuum vessel spool pieces, and two flux loops on each of the other two vacuum vessel spool pieces at the symmetry points. The latter are not installed on the VVSA and are therefore not covered in this plan. We will work to a Pro-E model for each Field Period Assembly (FPA) showing the flux loops, the routing of their leads, and the H/C tubes. Figure 1-2 shows two views from this model. The goal is to end up with the flux loops installed as shown in figure 1-1, the H/C tubes installed with approximately uniform coverage of the VVSA, and the flux loop leads routed on the surface of the VVSA and terminated in boxes located near the flanges of the large vertical ports.

### **1.2 Scope**

This document is not a procedure. It is meant to provide an overview of the dimensional control strategy for Stage 1 and to provide input into the installation and metrology procedures.

Field Period Assembly Station 1 Dimensional Control Plan  
NCSX-PLAN-FPA1DC-00

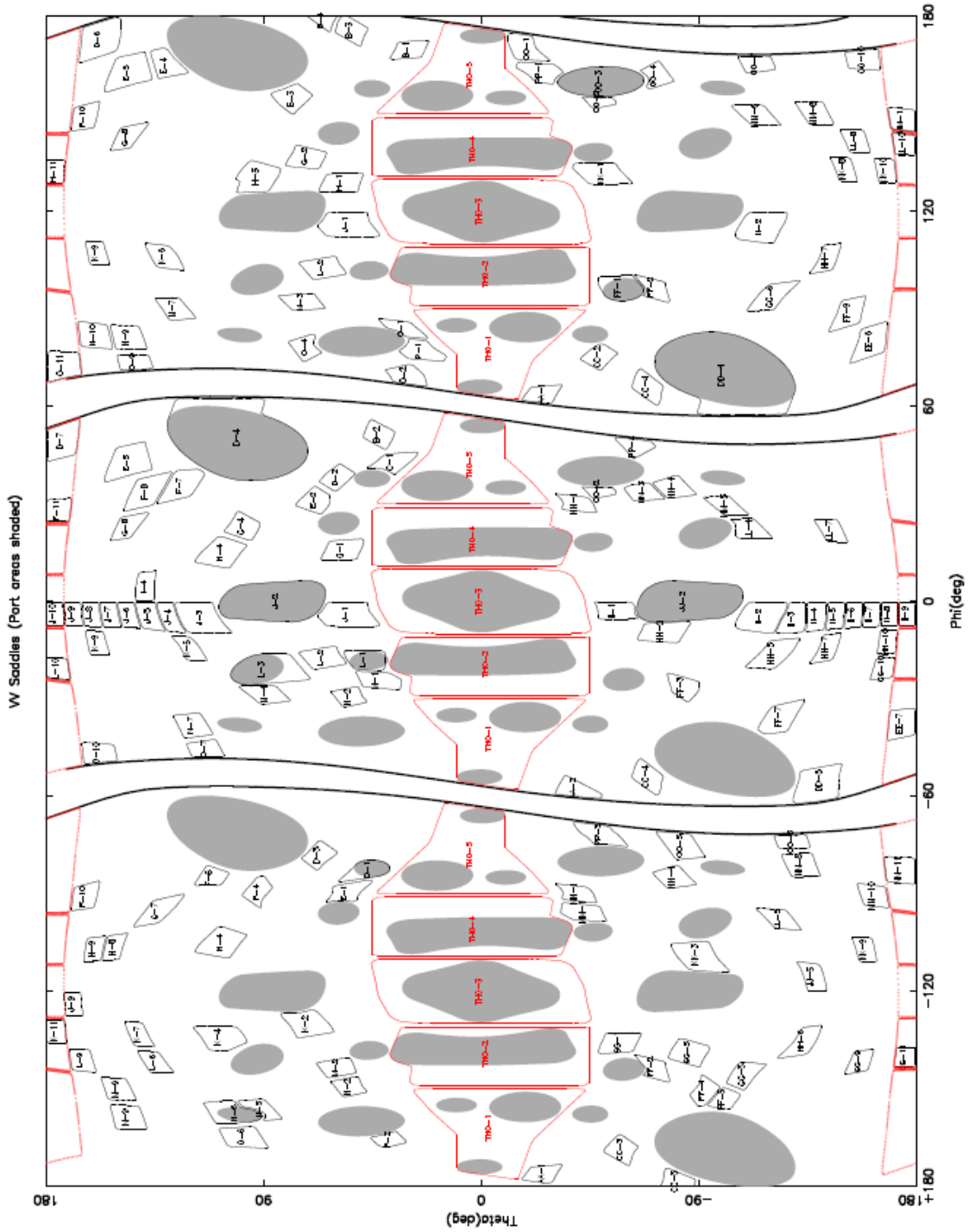
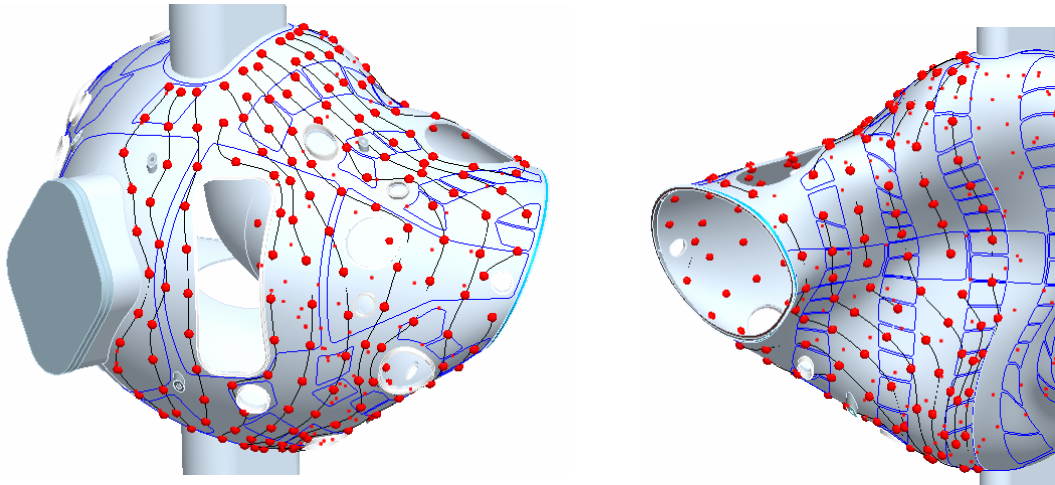

Figure 1-1 Flux Loop Layout on NCSX

**Field Period Assembly Station 1 Dimensional Control Plan**  
**NCSX-PLAN-FPA1DC-00**



**Figure 1-2 Flux Loops, H/C Tubes, and Flux Loop Lead Layout**

1.2.1 Reference Plans

This document along with the latest versions of the “NCSX Manufacturing Facility Operations Plan” [NCSX-PLAN-MFOP] and the “Field Period Assembly Manufacturing/Assembly, Inspection, Test and Quality Assurance Plan” [NCSX-PLAN-MITQA-142] will govern the field period assembly work on Station 1. The overall sequence of work at FPA Station 1 is given in the latest version of “Field Period Assembly (FPA) Assembly Station 1 Sequence Plan” [NCSX-Plan\_FPA\_Station\_1\_Sequence].

1.2.2 Reference Procedures

The field period assembly work at Station 1 will be performed according to the latest version of the FPA Station 1 installation and metrology procedures and other documents referred to in these procedures.

## **2 Field Period Assembly Station 1 Dimensional Control Steps**

This section outlines the dimensional control steps that will be followed during the FPA Station 1 installation work. Only installation steps that are important to dimensional control are given in this outline.

- 2.1. Review metrology data supplied by Major Tool before VVSA is shipped. Issue a memo stating summarizing the measurements with a recommendation on

**Field Period Assembly Station 1 Dimensional Control Plan**  
**NCSX-PLAN-FPA1DC-00**

whether or not the VVSA should be shipped. Hold a meeting to approve shipping the VVSA.

- 2.2. Receive VVSA and perform visual inspection.
- 2.3. Mount VVSA on VV prep fixture at the +60° position as shown in Figure 2-1. Mark the vertical up direction on both of the large vertical ports (port 12) and mark the toroidal direction on the shell of the VVSA. Note that access to the entire VVSA surface by the Laser Tracker or Romer Arm will require at least four positions of the VVSA on the VV prep fixture and two positions of the Laser Tracker or Romer Arm on each side of the VVSA. The VVSA will be turned and the Laser Tracker or Romer Arm moved as needed to perform the measurements and marking in the steps below. The +60° and -60° positions will be two of the positions used. After the VVSA is turned or the Laser Tracker or Romer Arm is moved, the fiducials must be measured and the Laser Tracker or Romer Arm must be re-aligned to the VVSA.

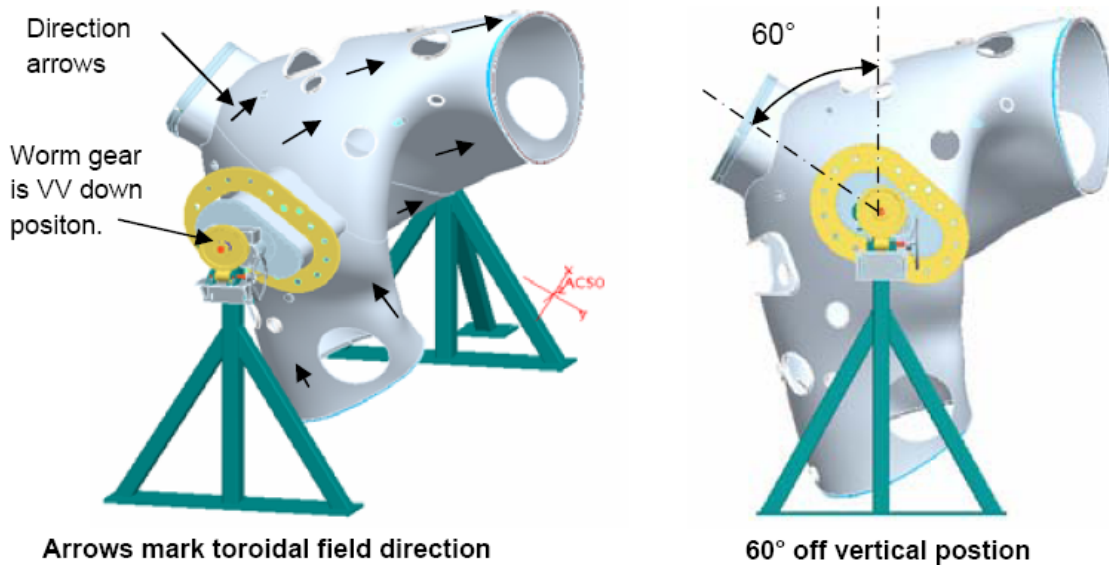
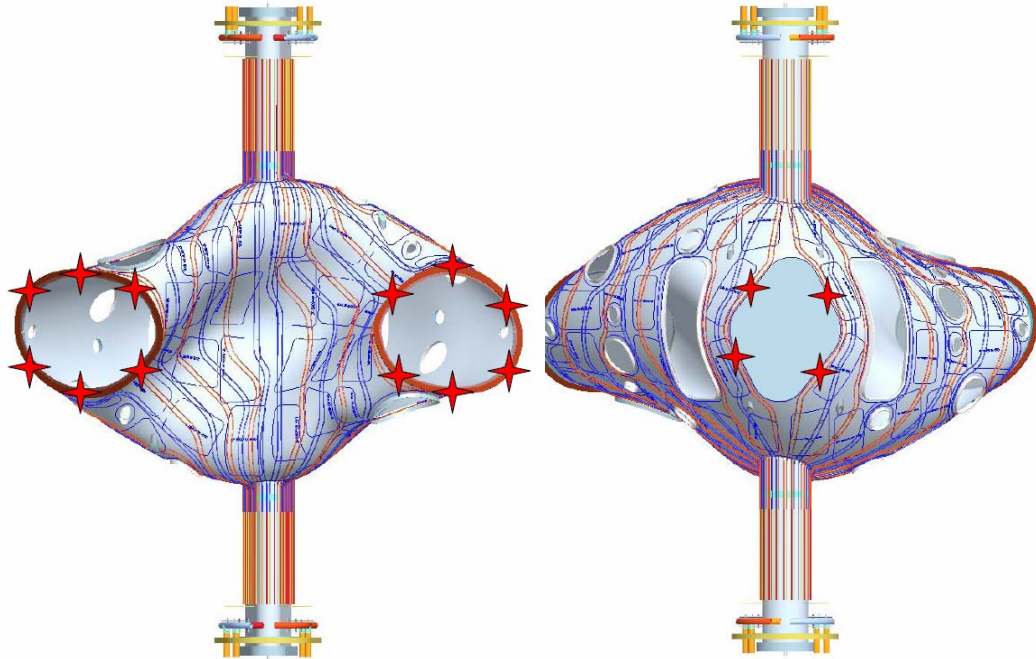

**Figure 2-1 VVSA Mounted on VV Prep Fixture in +60° Position**

- 2.4. Tack weld additional monument mounting pucks onto exterior surface of VVSA at 8-12 locations. The puck locations shall be chosen to not interfere with the flux loops or H/C studs and such that at least 4 monuments (pucks or MTM fiducials) are visible to the Laser Tracker with the VVSA in any position on the VV prep fixture. The pucks shall have a precision 1/4" hole to accept a standard Laser Tracker monument or Romer Arm monument on a 1/4" post. Note: These pucks will be removed at the end of work on Station 1.
- 2.5. Set up Laser Tracker and measure fiducials provided by Major Tool and Machine (MTM). Use fiducials on the inside and outside of the parting plane flanges and neutral beam port, as shown in Figure 2-2. These fiducials are indicated by red stars on Figure 2-2 on the parting plane flanges and neutral

**Field Period Assembly Station 1 Dimensional Control Plan**  
**NCSX-PLAN-FPA1DC-00**

beam flange. This will require at least two setups for the laser tracker. Use the 4 fiducials on the extreme edges of the end flanges (two at each end) to correlate data from the NBI port. The target-to-target measurements must repeat for the two setups within 0.005", or the measurements must be retaken. (The fiducials at the ends of the large vertical ports are excluded since calculations show large deflection of the vertical ports when the VVSA is mounted on the support fixture.) Perform a best fit to the fiducial measurements. Verify that VVSA mounting in support fixture is rigid enough that movement of VVSA during Laser Tracker measurements is not a source of error. (If this is a problem, i.e. the movement is more than 0.005", additional bracing of VVSA may be needed.) Check to see that measured fiducial locations are within 0.005" inches of nominal values supplied by MTM. Note: MTM's monuments are 1/4" precision reamed holes. Make sure that Laser Tracker monuments that we use are the same type as those used by MTM.

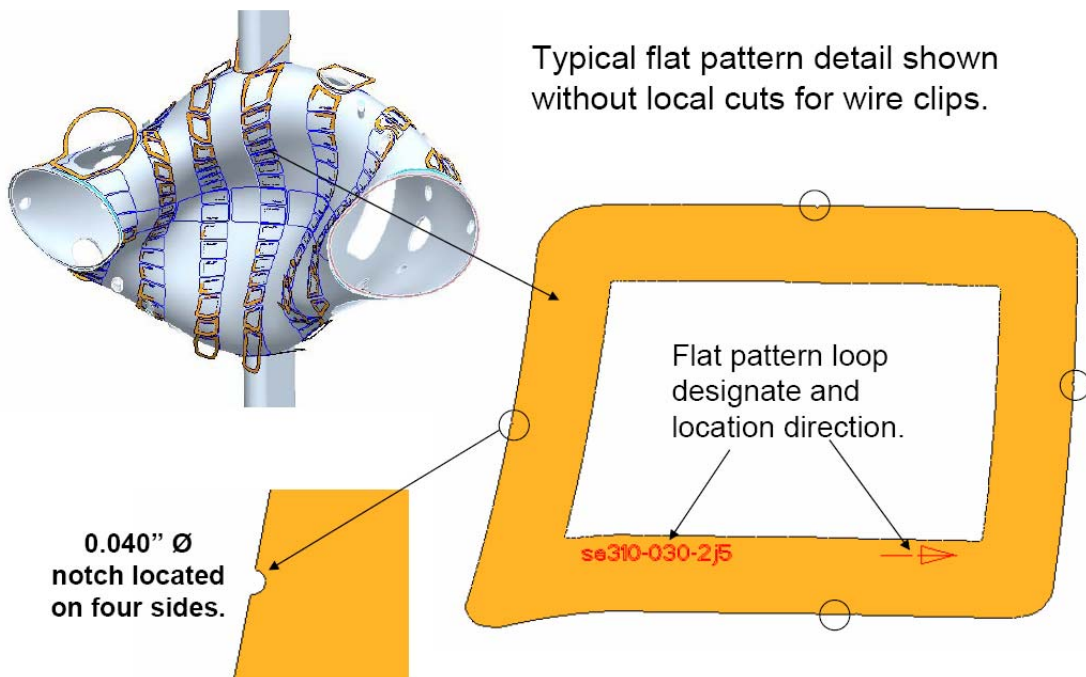

**Figure 2-2 VVSA Fiducials on Parting Plane Flanges and Neutral Beam Flange**

- 2.6. Measure locations of puck fiducials and incorporate into VVSA CAD model.
- 2.7. Measure VVSA surface with the VVSA and Laser Tracker positioned as needed. Spot check MTM's measurements in random locations spread out over VVSA surface. Perform more detailed measurements where MTM's measurements show the largest deviations from nominal values, especially in any out of tolerance areas.
- 2.8. Mark flux loop template locations (four per template) and H/C tube mounting clamp stud locations on VVSA using Laser Tracker or Romer Arm, moving the VVSA and Laser Tracker or Romer Arm as needed. This shall be done using a Pro-E model that includes the flux loops, H/C tubes, and flux loop lead routing. The flux loop template locations and H/C tube stud locations shall be marked

**Field Period Assembly Station 1 Dimensional Control Plan**  
**NCSX-PLAN-FPA1DC-00**

using a non-magnetic punch (e.g., made from Inconel 718). The flux loop template locations shall be labeled on the VVSA according to the same flux loop identification scheme used to label the templates. Notches in flux loop templates will be aligned with locating marks on the VVSA as shown in Figure 2-3. A circle with a diameter representing the larger of the region required by the stud welder or footprint of the H/C tube pads shall be drawn around each stud mark. The stud marks shall be connected by lines drawn on the VVSA indicating the nominal paths of the H/C tubes. The flux loop template locations shall be marked to  $\pm 1$  mm (0.040") or better, except for the loops at the symmetry points, which shall be marked to  $\pm 0.25$  mm (0.010") or better. The H/C tube stud locations shall be marked to  $\pm 3$  mm (0.120") or better. The arrow on each template will be oriented in the positive toroidal direction. The entire VVSA shall be marked before proceeding to the next step. Note that the VVSA surface may be offset from the nominal CAD surface used for measurement by as much as 3/16". Thus the location of the flux loop reference points will lay in a cylinder that is 3/8" tall ( $\pm 3/16$ ") and 0.040" in diameter. The axis of this cylinder is nominally normal to the CAD surface.

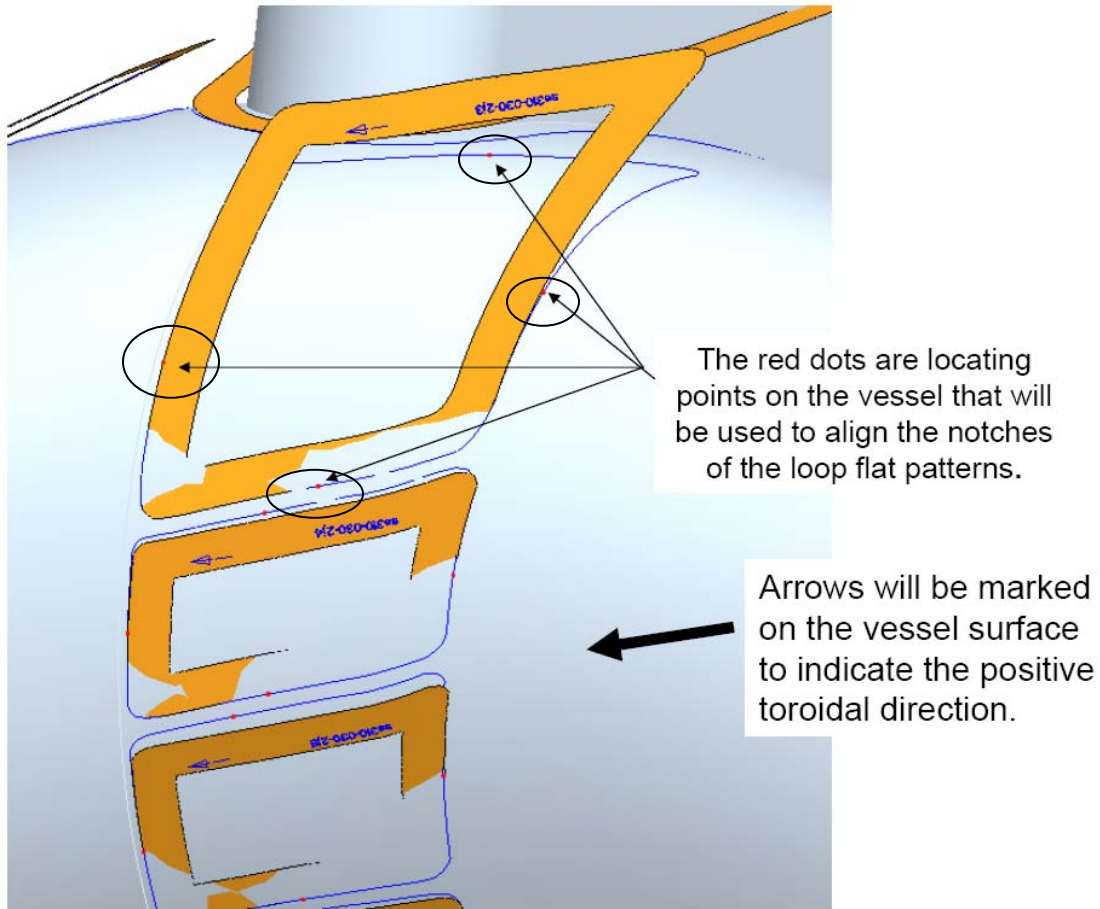

**Figure 2-3 Flux Loop Template Showing Designation, Orientation Arrow, and Fiducial Marks**

- 2.9. The VVSA shall also be marked in several places with arrows indicating the positive toroidal direction, consistent with the positive direction defined for flux loop installation, as shown in Figure 2-4.



**Field Period Assembly Station 1 Dimensional Control Plan  
NCSX-PLAN-FPA1DC-00**



**Figure 2-4 Location of Notches and Direction Arrows**

- 2.10. Check that the flux loop templates have been accurately fabricated and are correctly marked by laying each one on top of a full scale drawing of that template.
- 2.11. Install the flux loop templates on the VVSA according to the marks applied in the previous step, as shown in Figure 2-3 and Figure 2-4. Note that the name tag can be read right-side-up as installed. Along with the alignment of the template arrow with the positive toroidal direction marking on the VVSA, this indicates the correct alignment of the template. The templates shall be installed to within  $\pm 4$  mm (0.160") of the marked locations, except for the loops at the symmetry points, which shall be installed to within  $\pm 0.5$  mm (0.020") of the marked locations. This shall be done by aligning the four semicircular cutouts on the template edge with the four marks corresponding to that template. The arrow on each template shall be aligned with the arrows marked on the VVSA indicating the positive toroidal direction. During installation of the templates for the loops at the symmetry points, it may be necessary to make additional measurements with the Laser Tracker or Romer Arm to ensure placement within  $\pm 0.5$  mm (0.020") of their nominal locations. During template installation, check to see

**Field Period Assembly Station 1 Dimensional Control Plan**  
**NCSX-PLAN-FPA1DC-00**

that adequate space between loops is maintained where needed for lead routing according to the Pro-E model and that adequate clearance between the H/C tube pads/stud welder footprint and the loops is maintained. If necessary, the positions of the flux loop templates may be moved by up to 4 mm (0.160") in any direction to resolve interferences. An exception is the templates at the symmetry points, which may not be moved from their nominal locations. During this process, the positions of the H/C tube studs may be moved by up to 2" in any direction to resolve interferences, but care must be taken to keep the total path length for the H/C tube within  $\pm$  two inches of its nominal length. The templates are temporarily fixed to the VVSA with 0.010" thick stainless steel shim stock tabs tack welded to the VVSA to permit winding of the flux loops.

- 2.12. Install flux loops and remove templates, turning the VVSA as needed. The radial build of the flux loops should not exceed 1/16" at any location except where the inner turn of the loop crosses the outer turn where 1/8" is allowed. Twist leads to a pitch greater than 5/8 turns per inch and less than 3/4 turns per inch..
- 2.13. Run leads along VVSA according to Pro-E model, temporarily holding them in place with spot-welded shim stock straps every 1-2 feet as needed.
- 2.14. Install H/C tube studs. Note: can temporarily move flux loop leads to facilitate this process if necessary.
- 2.15. Install H/C tube clamps.
- 2.16. Perform final routing of flux loop leads and hold down with spot-welded shim stock straps spaced approximately 4" apart. The radial build of the twisted leads should not exceed 1/8", except in a few places (not under H/C tube paths) where it may be necessary for one set of leads to cross another.
- 2.17. Measure as-built paths of flux loops to within  $\pm 0.25$  mm (0.010"). This shall be done by tracing the groove between the two turns of each loop using either the Laser Tracker or the Romer Arm with a small probe tip. Ensure that these measurements, which will be cloud point data, are in a form that can be later used by the Physics Group for interpretation of the data from the flux loops. Measure several flux loops and transfer the data to the Physics Group to ensure that the data are useable. Resolve any problems before proceeding with measurement of all the loops.
- 2.18. Install H/C tubes, taking care to not move or damage the flux loops. If this does happen, note the locations of the affected loops so that they can be repaired and/or re-measured.
- 2.19. Terminate flux loops at boxes near flanges of large vertical ports.
- 2.20. Rotate VVSA to 180 ° position (neutral beam port down) and use scissors jack underneath neutral beam port to support weight of VVSA so that flexing of vertical ports is minimized. Measure fiducials on outside of vertical port flanges and compare nominal positions with data from MTM. Incorporate measurements into CAD model.

**Field Period Assembly Station 1 Dimensional Control Plan**  
**NCSX-PLAN-FPA1DC-00**

- 2.21. Install additional fiducial pucks (low-profile version) at pre-determined locations inside VVSA for later use with Romer Arm inside vessel when machine is fully assembled. Measure and record their locations at this time and after the ports are welded on. The second measurements will aid in setting up the VVSA locations at assembly and deriving the final machining dimensions for the spacers. .
- 2.22. Remove pucks installed in step 2.4.