

Modular Coil System (WBS14)

Interface Control Document (ICD)

NCSX-ICD-140-01
April 30, 2004

Prepared by: _____
D. Williamson, WBS 14

Concur: _____
P. Goranson, WBS 12

Concur: _____
P. Heitzenroeder, WBS 15

Concur: _____
G. Gettlefinger, WBS 16, 17, 62

Concur: _____
M. Cole, WBS 18

Concur: _____
D. Johnson, WBS 3

Concur: _____
R. Ramarishnan, WBS 4

Concur: _____
G. Oliaro, WBS 5

Concur: _____
B. Nelson, WBS 1

Approved: _____
W. Reiersen, Engineering Manager

Controlled Document

This is a controlled document. Check NCSX Engineering Web prior to use to assure that it is current.

Table of Contents

1 Introduction and Scope	3
1.1 Introduction.....	3
1.2 Scope.....	3
2 Applicable Documents.....	3
2.1 NCSX Documents.....	3
3 General Description	3
3.1 Vacuum Vessel (WBS 12).....	3
3.2 Coil Support Structure (WBS 15).....	3
3.3 Coil Services (WBS 16).....	4
3.4 Cryostat and Base Support Structure (WBS 17).....	4
3.5 Field Period Assembly (WBS 18).....	4
3.6 Diagnostics (WBS 3)	4
3.7 Electrical Power Systems (WBS 4)	4
3.9 Central I&C Systems (WBS 5).....	4
3.10 Cryogenic Systems (WBS 62)	4
4 Interface Worksheets	5

1 Introduction and Scope

1.1 Introduction

The National Compact Stellarator Experiment (NCSX) is an experimental research facility that is to be constructed at the Department of Energy's Princeton Plasma Physics Laboratory (PPPL). Its mission is to acquire the physics knowledge needed to evaluate compact stellarators as a fusion concept, and to advance the understanding of 3D plasma physics for fusion and basic science.

A primary component of the facility is the stellarator core, an assembly of four magnet systems that surround a highly shaped plasma and vacuum chamber. The four coil systems include the modular coils, the poloidal field (PF) coils, the toroidal field (TF) coils, and the external trim coils. These coils provide the magnetic field required for plasma shaping and position control, inductive current drive, and error field correction.

1.2 Scope

This document, the Interface Control Document (ICD) for the Modular Coil System (WBS14), defines the functional and physical interfaces between the modular coils and other subsystems within the stellarator core.

2 Applicable Documents

2.1 NCSX Documents

- Modular Coil System Requirements Document, NCSX-BSPEC-140-00
- NCSX Interface Drawings:
 - TBD

3 General Description

3.1 Vacuum Vessel (WBS 12)

The vacuum vessel is supported mechanically by the modular coils structural shell and is insulated to prevent a large heat leak during bakeout and operation.

3.2 Coil Support Structure (WBS 15)

The coil support structure interfaces with the machine base and provides an integrated support of the modular coils, toroidal field (TF) coils, and poloidal field (PF) coils. The modular coils have a direct mechanical interface with the support structure.

3.3 Coil Services (WBS 16)

Coil services includes cooling, electrical feeds, and coil protection circuitry for the modular coils. The modular coils have specified interface locations for the connection to the LN2 manifold and electrical busswork inside the cryostat.

3.4 Cryostat and Base Support Structure (WBS 17)

This WBS element does not interface with the modular coils directly, but maintains a defined gap or clearance for the cryostat nitrogen environment. A minimum radial build for the space envelope is defined.

3.5 Field Period Assembly (WBS 18)

The tooling required for field period assembly interfaces with the modular coils at specified lift points. In addition, monuments are required to facilitate position measurements.

3.6 Diagnostics (WBS 3)

Magnetic diagnostics loops are attached to the modular coil winding packs and have an entry/exit point at the coil leads location.

3.7 Electrical Power Systems (WBS 4)

Power systems is responsible for providing the necessary current and voltage to the modular coils, for providing coil protection circuitry, and for maintaining an electrical ground to all components. Physical interfaces are described in the Coil Services section.

3.9 Central I&C Systems (WBS 5)

Central I&C takes output from the modular coil sensors (strain gauges, RTDs, thermocouples) and processes it for use in the facility control logic. The physical interface between I&C and the modular coils is described.

3.10 Cryogenic Systems (WBS 62)

Cryogenic systems is responsible for providing liquid and gaseous nitrogen for cooling of the modular coils. Physical interfaces are described in the Coil Services and Cryostat sections.

4 Interface Worksheets

<u>INTERFACE CONTROL DOCUMENT TITLE AND APPROVAL PAGE</u>		
<u>(Page 1)</u>		
ICD Number: ICD-14-12-01	Primary Author: D. Williamson	
Impacted WBS Elements: 14, 12	<u>Type of Interface:</u> Mechanical	
<p>Description of Interface: The modular coil system supports vertical and lateral loads from the vacuum vessel and is thermally insulated to minimize the heat leak during bakeout and operation. Fig. 1 describes the room temperature position of the vessel supports.</p>		
Record of Revisions		
Revision Numbr	Description	Date
0	Initial issue.	5/2/04
Approvals		
WBS Manager: P. Goranson		WBS Manager: D. Williamson
Project Engineer: B. Nelson		Project Engineer:
Systems Engineering Support Manager: R. Simmons		

ICD DETAIL SHEET

(Page 2)

(Use Continuation Sheets as Necessary to Include the Following Applicable Information)

Scope of Interface:

This interface affects the design of the modular coils and coil support structure.

Equipment and Responsibility List:

Modular Coils (WBS 14) – Williamson

Vacuum Vessel (WBS12) - Goranson

Related ICDs:

None.

Notes and Abbreviations:

None.

Interface Block Diagrams:

Fig. 1 goes here.

Installation Information:

None.

Other Pertinent Information:

None.

INTERFACE CONTROL DOCUMENT TITLE AND APPROVAL PAGE

(Page 1)

ICD Number: ICD-14-15-01

Primary Author: D. Williamson

Impacted WBS Elements: 14, 15

Type of Interface: Mechanical

Description of Interface:

The modular coil system and coil support structure shall provide matching interfaces for the purpose of transmitting gravity and electromagnetic loads. The room temperature dimensions and position of the interface points are described in Fig. 2.

Record of Revisions

Revision Number	Description	Date
0	Initial issue.	5/2/04

Approvals

WBS Manager: P. Heitzenroeder	WBS Manager: D. Williamson
Project Engineer: B. Nelson	Project Engineer:
Systems Engineering Support Manager: R. Simmons	

ICD DETAIL SHEET

(Page 2)

(Use Continuation Sheets as Necessary to Include the Following Applicable Information)

Scope of Interface:

This interface affects the design of the modular coils and coil support structure.

Equipment and Responsibility List:

Modular Coils (WBS 14) – Williamson

Coil Support Structure (WBS 15) - Heitzenroeder

Related ICDs:

None.

Notes and Abbreviations:

None.

Interface Block Diagrams:

Fig. 2 goes here.

Installation Information:

None.

Other Pertinent Information:

None.

INTERFACE CONTROL DOCUMENT TITLE AND APPROVAL PAGE

(Page 1)

ICD Number: ICD-14-16-01

Primary Author: D. Williamson

Impacted WBS Elements: 14, 16

Type of Interface: Thermo-hydraulic

Description of Interface:

The modular coils shall provide cooling inlet and outlet connections to the LN2 manifold at the locations shown in Fig.3.

Record of Revisions

Revision Number	Description	Date
0	Initial issue.	5/2/04

Approvals

WBS Manager: G. Gettlefinger	WBS Manager: D. Williamson
Project Engineer: B. Nelson	Project Engineer:
Systems Engineering Support Manager: R. Simmons	

ICD DETAIL SHEET

(Page 2)

(Use Continuation Sheets as Necessary to Include the Following Applicable Information)

Scope of Interface:

This interface affects the design of the modular coils and cryostat LN2 manifold.

Equipment and Responsibility List:

Modular Coils (WBS 14) – Williamson

LN2 Distribution System (WBS 161) – Gettelfinger

Related ICDs:

None.

Notes and Abbreviations:

None.

Interface Block Diagrams:

Fig. 3 goes here.

Installation Information:

None.

Other Pertinent Information:

None.

INTERFACE CONTROL DOCUMENT TITLE AND APPROVAL PAGE

(Page 1)

ICD Number: ICD-14-16-02

Primary Author: D. Williamson

Impacted WBS Elements: 14, 16

Type of Interface: Electrical

Description of Interface:

The modular coils shall provide electrical connections at the locations shown in Fig. 4.

Record of Revisions

Revision Number	Description	Date
0	Initial issue.	5/2/04

Approvals

WBS Manager: G. Gettlefinger	WBS Manager: D. Williamson
Project Engineer: B. Nelson	Project Engineer:
Systems Engineering Support Manager: R. Simmons	

ICD DETAIL SHEET

(Page 2)

(Use Continuation Sheets as Necessary to Include the Following Applicable Information)

Scope of Interface:

This interface affects the design of the modular coils and cryostat busswork.

Equipment and Responsibility List:

Modular Coils (WBS 14) – Williamson

Cryostat Busswork (WBS 162) – Gettelfinger

Related ICDs:

None.

Notes and Abbreviations:

None.

Interface Block Diagrams:

Fig. 4 goes here.

Installation Information:

None.

Other Pertinent Information:

None.

INTERFACE CONTROL DOCUMENT TITLE AND APPROVAL PAGE

(Page 1)

ICD Number: ICD-14-17-01

Primary Author: D. Williamson

Impacted WBS Elements: 14, 17

Type of Interface: Thermal

Description of Interface:

The modular coils shall maintain a nominal clearance within the cryostat for the nitrogen environment. The minimum radial build is described in Fig. 5.

Record of Revisions

Revision Number	Description	Date
0	Initial issue.	5/2/04

Approvals

WBS Manager: G. Gettlefinger	WBS Manager: D. Williamson
Project Engineer: B. Nelson	Project Engineer:
Systems Engineering Support Manager: R. Simmons	

ICD DETAIL SHEET

(Page 2)

(Use Continuation Sheets as Necessary to Include the Following Applicable Information)

Scope of Interface:

This interface affects the design of the modular coils and cryostat.

Equipment and Responsibility List:

Modular Coils (WBS 14) – Williamson

Cryostat (WBS 17) – Gettelfinger

Related ICDs:

None.

Notes and Abbreviations:

None.

Interface Block Diagrams:

Fig. 5 goes here.

Installation Information:

None.

Other Pertinent Information:

None.

INTERFACE CONTROL DOCUMENT TITLE AND APPROVAL PAGE

(Page 1)

ICD Number: ICD-14-18-01

Primary Author: D. Williamson

Impacted WBS Elements: 14, 18

Type of Interface: Thermal

Description of Interface:

The modular coils interface with tooling for field period assembly at the positions shown in Fig. 6.

Record of Revisions

Revision Number	Description	Date
0	Initial issue.	5/2/04

Approvals

WBS Manager: M. Cole	WBS Manager: D. Williamson
Project Engineer: B. Nelson	Project Engineer:
Systems Engineering Support Manager: R. Simmons	

ICD DETAIL SHEET

(Page 2)

(Use Continuation Sheets as Necessary to Include the Following Applicable Information)

Scope of Interface:

This interface affects the design of the modular coils and cryostat.

Equipment and Responsibility List:

Modular Coils (WBS 14) – Williamson
Field Period Assembly (WBS 18) - Cole

Related ICDs:

None.

Notes and Abbreviations:

None.

Interface Block Diagrams:

Fig. 6 goes here.

Installation Information:

None.

Other Pertinent Information:

None.

INTERFACE CONTROL DOCUMENT TITLE AND APPROVAL PAGE

(Page 1)

ICD Number: ICD-14-310-0003

Primary Author: B. Stratton

Impacted WBS Elements: WBS-3 to WBS-14

Type of Interface: Mechanical/Envelope Interface





Description of Interface:

Diagnostic magnetic field sensor loops shall be co-wound with the modular field coils. Two sensor loops are required for each modular coil. They shall be located on top of the modular coil winding pack (facing plasma), with one sensor loop on each side of the center leg of the winding form tee.

Record of Revisions

Revision Number	Description	Date
0	Initial Issue	April 14, 2003
1	Defined responsibilities of WBS3 and WBS14	April 28, 2003
2	Defined accuracy of coil positions	May 1, 2003
3	Defined requirement for sensor loop termination	May 6, 2003

Approvals

WBS Manager:  David Johnson <small>Digitally signed by David Johnson DN: cn=David Johnson, c=US Date: 2003.05.22 10:18:00 -0400</small>	WBS Manager:  David Williamson <small>2003.05.12 09:46:40 -04'00'</small>
Project Engineer:  Brad Nelson <small>2003.05.09 16:17:56 -04'00'</small>	Project Engineer:  Larry Dudek <small>Digitally signed by Larry Dudek DN: cn=Larry Dudek, c=US Date: 2003.05.19 14:56:13 -0400</small>
Systems Engineering Support Manager:  Robert Simmons <small>2003.05.23 12:56:50 -04'00'</small>	

ICD DETAIL SHEET

ICD-14-310-0003

(Page 2)

(Use Continuation Sheets as Necessary to Include the Following Applicable Information)

Scope of Interface:

This interface impacts the design and fabrication of the modular coils (WBS14) and magnetics diagnostics (WBS3).

Equipment and Responsibility List:

Modular Coils (WBS 14): Williamson

Magnetics Diagnostics (WBS 3): Johnson

Related ICDs:

Notes and Abbreviations:

Interface Block Diagrams:

Cross section of modular coil showing co-wound sensor loops:

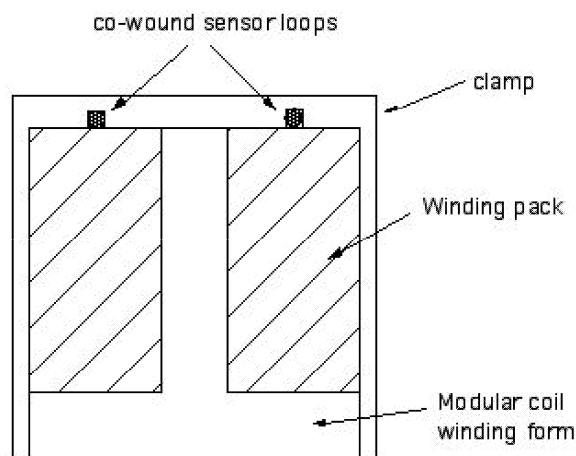

Installation Information:

The co-wound sensor loops shall be installed during winding of the modular coils. Installation of the sensor loops will be the responsibility of WBS14. This installation, as part of coil manufacture, shall include lead termination at the coil casing (or boundary). The leads are to be terminated in a heavy duty structure, rigidly attached to the coil and capable of protecting the leads from breakage for the coil lifetime. The dual sensors are for redundancy and the terminating structures should be appropriate to this function. All other work related to these sensor loops (e. g., connections to instrumentation) will be the responsibility of WBS3.

Other Pertinent Information:

The sensor loops shall be laid on top of the winding pack before epoxy impregnation and held in place by the winding clamps (grooves on the inside of each clamp are required). The epoxy will hold the sensor loops in place after impregnation. The sensor loops shall be made of suitable thin cable such as mineral insulated cable (diameter: 0.061" or less). The two leads for each loop shall be brought out through holes in the center leg of the winding form tee. The reliability of the sensor loops shall be at the same level as the reliability of the modular coils. The loops shall be positioned within 1/16" of the design position and their positions shall be known to the same accuracy as that of the modular coils themselves.

INTERFACE CONTROL DOCUMENT TITLE AND APPROVAL PAGE

(Page 1)

ICD Number: ICD-14-40-01

Primary Author: D. Williamson

Impacted WBS Elements: 14, 4

Type of Interface: Electrical

Description of Interface:

The location of the modular coil electrical ground connection is shown in Fig. 7.

Record of Revisions

Revision Number	Description	Date
0	Initial issue.	5/2/04

Approvals

WBS Manager: R. Ramarishnan	WBS Manager: D. Williamson
Project Engineer: B. Nelson	Project Engineer: L. Dudek
Systems Engineering Support Manager: R. Simmons	

ICD DETAIL SHEET

(Page 2)

(Use Continuation Sheets as Necessary to Include the Following Applicable Information)

Scope of Interface:

This interface affects the design of the modular coils and cryostat.

Equipment and Responsibility List:

Modular Coils (WBS 14) – Williamson

Electrical Power Systems (WBS4) - Ramarishnan

Related ICDs:

None.

Notes and Abbreviations:

None.

Interface Block Diagrams:

Fig. 7 goes here.

Installation Information:

None.

Other Pertinent Information:

None.

INTERFACE CONTROL DOCUMENT TITLE AND APPROVAL PAGE

(Page 1)

ICD Number: ICD-14-50-01

Primary Author: D. Williamson

Impacted WBS Elements: 14, 5

Type of Interface: Electrical

Description of Interface:

The location of the modular coil sensors (strain gauges, RTDs, thermocouples) is described in Fig. 8.

Record of Revisions

Revision Number	Description	Date
0	Initial issue.	5/2/04

Approvals

WBS Manager: G. Oliaro	WBS Manager: D. Williamson
Project Engineer: B. Nelson	Project Engineer: L. Dudek
Systems Engineering Support Manager: R. Simmons	

ICD DETAIL SHEET

(Page 2)

(Use Continuation Sheets as Necessary to Include the Following Applicable Information)

Scope of Interface:

This interface affects the design of the modular coils and cryostat.

Equipment and Responsibility List:

Modular Coils (WBS 14) – Williamson

Central I&C (WBS 5) - Oliaro

Related ICDs:

None.

Notes and Abbreviations:

None.

Interface Block Diagrams:

Fig. 8 goes here.

Installation Information:

None.

Other Pertinent Information:

None.