

**National Compact Stellarator Experiment**

**NCSX**

**SPECIFICATION**

**FOR**

**Preconceptual Costing of the  
Toroidal Field Coils**

**DATED:** April 23, 2002

PREPARED BY: \_\_\_\_\_  
P. Heitzenroeder

**PRINCETON UNIVERSITY  
PLASMA PHYSICS LABORATORY  
(PPPL)  
P.O. BOX 451  
PRINCETON, N.J. 08543**

## RECORD OF CHANGE

<b>Revision</b>	<b>Date</b>	<b>TRB</b>	<b>Description of Change</b>

## **1.0 INTRODUCTION AND SCOPE:**

1.1 INTRODUCTION: this draft specification and specified attachments are to be the basis of a conceptual level cost estimate for the toroidal field coils of the NCSX device. *It is only meant to be used for that purpose.* This specification was adopted from those used for the recently constructed NSTX device in order to provide PPPL's standard quality assurance, general conditions, and reporting requirements. Since this material is only at the preconceptual level, some inconsistencies and omissions are to be expected; in such cases, please call Phil Heitzenroeder at 609-243-3043, fax \_3030, e-mail [pheitzen@pppl.gov](mailto:pheitzen@pppl.gov) or Tom Brown at 609-243-2156, fax \_3030, e-mail [tbrown@pppl.gov](mailto:tbrown@pppl.gov) for clarification or guidance. Please document the basis of your estimate as fully as possible, including assumptions made. Costing is a major issue for NCSX; consequently, suggestions, which may reduce costs, are most welcome.

### 1.2 SCOPE

- a. This specification defines the manufacturing requirements for the National Compact Stellarator Experiment (NCSX) TF coil windings. The coil cases and other structural elements are not a part of this specification or costing effort.
- b. Subcontractor shall furnish all material, labor and facilities necessary to complete the work as defined in the contract documents subject to the qualifications, conditions, and exceptions noted herein. This includes:
  - Copper conductor and fabrication of the welded turns;
  - "S" glass turn-to-turn and ground insulation.
  - Conductive ground plane paint application.

## **2.0 APPLICABLE DOCUMENTS:**

### **2.1 DRAWINGS**

- a. PPPL will supply a basic set of drawings (top view, side view, section view, assembly). The vendor is to produce manufacturing details and manufacturing drawings as part of this scope of work.
- b. Dimensions in drawings and specifications refer to conditions at room temperature (20° C/ 68° F).

### **2.2 STANDARDS AND CODES:**

Materials and manufacturing/test methods used in fabrication of the equipment covered by this specification shall comply with the latest revision, in effect at date of purchase

order, of the following currently approved applicable regulations, safety codes, specifications and standards, including applicable technical definitions as acknowledged and accepted in industry.

### **CDA Copper Development Association**

CDA Standards Handbook, Part 2 (Wrought Products) Alloy Data, CDA Alloy No. 10200 or CDA 10700 (Oxygen Free High Conductivity Copper).

### **Conductor Material:**

The hollow copper conductor is to be extruded and drawn.

### **IEEE- Institute of Electrical and Electronic Engineers**

IEEE #4, Techniques for Dielectric Tests

### **NEMA-National Electrical Manufacturers Association**

- a. Grades and specifications for materials developed for the electric and electronics industries.
- b. The above Standards and Codes set forth the minimum requirements. They may be exceeded by Subcontractor with written permission from PPPL, if in Subcontractor's judgment, superior or more economical designs or materials are available for successful and continuous operations, as required by the specification.

## **2.3 GENERAL STATEMENT**

Subcontractor agrees, represents and warrants that all services, designs, equipment and material sold or otherwise provided to PPPL by Subcontractor comply with applicable, Federal, State and Local laws, regulations and codes, and all applicable specifications and standards including those specified above, in each case as in effect at the date of order placement. Subcontractor shall provide PPPL with a Certificate of Compliance identifying the codes, standards and regulations complied with, and any exceptions taken, in the design and fabrication of deliverable items.

## **3.0 REQUIREMENTS:**

### **3.1 EQUIPMENT DEFINITION**

#### **3.1.1 General Design Features**

- a. General design features and dimensional characteristics of the coils are given in Table 3.1.1-1 and in Dwg. 3.1.1-1:

**Table 3.1.1-1. NCSX TF Coil Design Features and Dimensional Characteristics**

Number of Coils	18
Turns High	3
Turns Wide	4
Total Turns	12
Double pancake length, m	51.942
Bundle Height, mm	87.096
Bundle Width, mm	99.906
Bundle Area, mm <sup>2</sup>	8701.41
Bundle Area, m <sup>2</sup>	0.009
Conductor Height, mm	27
Conductor Width, mm	22.5
Corner Radius, mm	2.5
Cooling Hole Dia., mm	13.5
Conductor Area, mm <sup>2</sup>	459.00
Max current in reference scenario, kA	14.28
Weight/coil. ka	4.09E+02

b. TF Coil Assembly insulation builds and details are described in Table 3.1.1-2:

**Table 3.1.1-2. NCSX TF Coil Insulation Builds and Details**

<b>Insulation Type:</b>	Vacuum pressure impregnated (VPI) "S" Glass/Epoxy.
<b>Ground Wrap</b> build, mm:	0.762
Ground wrap tape thickness, mm	0.19
No. half lapped layers:	4
<b>Turn Insulation</b> build, mm:	0.762
Turn tape thickness, mm	0.19
No. Half lapped layers:	4
<b>Pancake Insulation</b> , mm	0.762
Pancake tape thickness, mm	0.19
No. Half lapped layers:	4

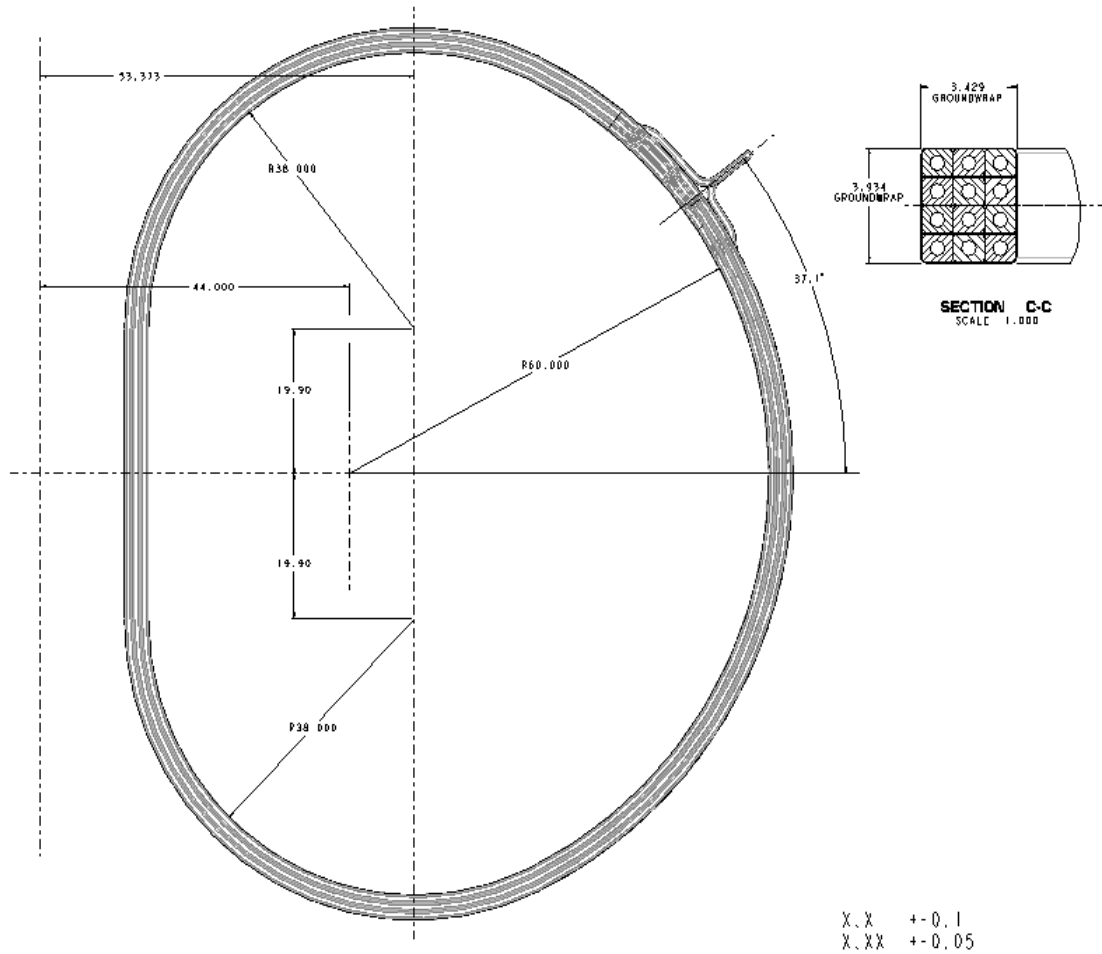

**Fig. 3.1.1-1. NCSX Toroidal Field Coil Details**

- c. Tolerances: Coils shall be in plane (flat) within +/- 1mm. The center position of the coil bundle shall be within +/- 1mm of the drawing position when measured at any position along the coil.

### 3.1.2 **Materials:**

#### 3.1.2.1 **Copper Conductor**

- a) Dimensions as given in Table 3.1.1-1.
- b) Copper shall be supplied with a minimum yield of 30 ksi (0.5% elongation).
- c) Electrical conductivity shall be 100% IACS (min.) at 20 degrees C.
- d) The copper conductor is to be procured and supplied by the vendor. All generated scrap and excess material furnished by PPPL shall remain the property of PPPL. A material inventory, defining quality, condition and quantity of excess material shall be maintained and submitted at the conclusion of the job. PPPL shall instruct Subcontractor as to the disposition of excess materials at PPPL's expense.

- 3.1.2.2 Insulation System: all insulating materials to be supplied as part of this contract. Vendor selection of material subject to PPPL approval.

#### 3.1.2.5 **Degreasing/Cleaning Solvent:**

All conductors shall be degreased/cleaned using a solvent which has been pre-approved by PPPL. This solvent must be able to dissolve grease, tar, wax, adhesives, oils and other soils, and be residue free.

#### 3.1.2.6 **Machined Coil Lead Blocks and Electrical Flags:**

Machined blocks for coil leads shall be fabricated from copper bar or plate. Alloy shall be CDA alloy no.10200 or 10700 oxygen free copper having a minimum yield strength of 30,000 psi (0.5% elongation).

## 3.2 **COIL FABRICATION**

This section describes a recommended procedure for fabricating the subject equipment. The Subcontractor shall submit for approval by PPPL, a Manufacturing, Inspection, and Test (MIT) plan. No deviations from the MIT plan will be accepted without PPPL approval.

### 3.2.1 **Copper Conductor Delivery:**

The copper conductors shall be delivered as conductor pre-finished to the proper thickness and profiles. The crates shall be inspected for visual damage by the Subcontractor and condition of crates documented.

### 3.2.2 **Conductor Inspection:**

Each copper conductor shall be removed from its container moved to an inspection station where they will be inspected per requirements in Section 4.0 paragraph 4.1. An identification number shall be metal stamped onto the end of each conductor.

### 3.2.4 **Conductor Inspection:**

At the conclusion of the forming operations, the conductors shall be inspected per requirements in section 4.0 paragraph 4.2.1. Inspection and test results shall be recorded and included with the Process History package.

### 3.2.5 **Conductor Joining**

Induction silver brazing using "Sil-Fos" shall be used for all turn-to-turn joints. Vendor to develop the process details, helium leak test and pull test requirements, and technician qualification program.

### 3.2.7 **Flow and Hydrostatic Tests:**

Flow, hydrostatic leak tests, and helium leak tests shall be performed per requirements in section 4.2.3 to verify integrity of the coolant passages and to provide a base line for future tests.

### 3.2.8 **Conductor Cleaning**

Each conductor shall be wiped down with degreasing solvent to remove excess oil, lubricant and grease.

### 3.2.9 **Material Protection:**

Cleaned copper, whether bare or insulated, shall be stored and processed in an environment free from metallic dust or other contaminants. After cleaning, the copper surface and insulating materials shall be protected from skin oil, etc., by requiring shop personnel to handle conductors only while wearing clean, lint free, white cotton gloves. Insulation and in-process subassemblies shall be processed and stored in controlled clean areas.

### 3.2.22 **Final Inspection and Test:**



The inspections and tests in section 4.0 paragraph 4.2.1 shall be performed once each Assembly is in a deliverable state.

#### **4.0 INSPECTION & TEST REQUIREMENTS**

Mechanical and electrical inspections and tests shall be performed on each Assembly. Results of the inspections and tests are to be provided to PPPL as part of the Process History (reference paragraph 5.12). Seller shall notify PPPL a minimum of 5 days in advance to permit PPPL's representatives to witness any of the inspections or tests, either in process or final acceptance.

#### **4.1 RECEIVING INSPECTION- TF CONDUCTOR**

##### **4.1.1 Dimensional Measurements/Inspections**

- a. Conductors shall be checked to verify that length and cross sectional dimensions are within the required tolerance on the approved PPPL drawings. They will also be inspected for excessive twist, warp and camber.
- b. The dc resistance and temperature of each conductor shall be measured and recorded.
- c. A Rockwell hardness test shall be performed to check the conductor hardness. These values shall become the baseline values for comparison checks throughout the fabrication process.

#### **4.2 IN-PROCESS TESTING**

##### **4.2.1 Tests After Conductors have been Joined**

- a. Conductors shall be dimensional checked to verify that the formed conductors are within the required tolerance on the approved PPPL drawings.
- b. A Rockwell hardness test shall be performed on each formed conductor to verify the conductor hardness following the forming operation.
- c. Helium Leak Test: The conductor shall be pressurized by helium at 50 psi. A mass spectrometer "sniffer" shall capable of detecting leaks  $<10^{-5}$  used to detect leakage at the tube to conductor connections. .

#### **4.3 FINAL ACCEPTANCE TESTS**

These tests and inspections shall be performed once the coil assemblies are in a deliverable configuration.

#### 4.3.1 **Inspection:**

A complete visual inspection and dimensional check shall be made according to applicable drawings.

#### 4.3.2 **Flow/Pressure Tests**

A final flow and hydrostatic pressure test of the coils shall be made. These tests shall be performed using potable water. Operational flow rates and pressure drops shall be within 10% of the calculated flow rate (to be supplied by PPPL).

#### 4.3.3 **Final Electrical Tests**

- a. Coils shall be temporarily wrapped with conducting material (e.g. Al foil) to provide a ground plane.
- b. The insulation between the coil and case shall be verified by applying a **3 kV** Megger between each individual conductor and the remainder of the conductors, which shall be shorted and grounded. Insulation resistance shall be greater than **1000 MΩ**.

## 5.0 **QUALITY ASSURANCE REQUIREMENTS**

### 5.1 **INSPECTION/ SURVEILLANCE/AUDIT BY PRINCETON**

Authorized representatives of PPPL and the U. S. Government shall have the right at all reasonable times to visit the Subcontractor's premises and those of Subcontractor's suppliers during the performance of the procurement for the purposes of inspection, surveillance, audit and/or obtaining any required information as may be necessary to assure that items or services are being furnished in accordance with specified requirements. Such visits shall be coordinated with the Subcontractor's personnel to minimize interference with the normal operations of said premises. The Subcontractor shall make available records and documentation necessary for this function and shall provide all reasonable facilities and assistance for the safety and convenience of PPPL and/or U. S. Government representatives in the performance of their duties. PPPL and the U. S. Government recognize the Subcontractor's right to withhold information concerning proprietary processes. The Subcontractor agrees to insert the paragraph above in each lower tier procurement issued hereunder.

### 5.2 **SUBCONTRACTOR'S RESPONSIBILITY FOR CONFORMANCE**

Neither PPPL's review and/or approval of Subcontractor's documents nor PPPL's inspection of Subcontractor's items or services shall relieve the Subcontractor of responsibility for full compliance with requirements of the purchase order/contract.

### **5.3 QUALITY ASSURANCE PLAN**

Subcontractor shall submit two (2) copies of its Quality Assurance Plan, describing the specific quality assurance and quality control procedures and practices to meet the requirements of this particular subcontract/purchase order, for PPPL review and approval. (Reference Section 6.2)

### **5.4 MANUFACTURING, INSPECTION AND TEST PLAN (MIT)**

Subcontractor shall prepare and submit for PPPL review and approval a Manufacturing/Inspection/Test Plan which identifies parts, sub-assemblies, etc.; shows their integrated flow into end items; and identifies critical manufacturing operations as well as inspections and tests. Preparing the Plan may include developing a flow chart and generating Process Sheets/Shop Travelers, etc. PPPL may designate selected manufacturing, inspection and/or test operations as mandatory "witness" points based on the MIT plan. Subcontractor shall provide PPPL with five (5) working days notice in advance of such witness points.

### **5.5 INSPECTION AND TEST PROCEDURES**

Inspections and tests shall be performed in accordance with written procedures referencing criteria for acceptance or rejection. Each inspection and test shall be documented.

### **5.6 DOCUMENT TRACEABILITY AND RECORDS**

The Subcontractor shall maintain a system of documentation whereby objective evidence of required operations, inspections, examinations, and tests is systematically compiled, indexed and stored. Such objective evidence may include "travelers"; and material test, certification, inspection, examination, test and discrepancy reports; which shall be complete, legible, and validated by responsible personnel and shall be traceable to subject items.

### **5.7 EQUIPMENT/MATERIAL IDENTIFICATION AND STATUS**

Material and equipment identification shall be maintained throughout the program and be traceable to the records. Status of acceptability shall be readily discernible

through the Subcontractor's use of tags, stamps, serial numbers or other positive means.

## **5.8 CALIBRATION OF TEST AND MEASURING EQUIPMENT**

Inspections and tests shall be performed using properly calibrated measuring and test equipment. Subcontractor shall have in its possession the necessary equipment to perform the required inspections and tests. Calibration standards shall be traceable to the National Institute for Standards and Technology (NIST) or equivalent. Subcontractor shall impose these calibration requirements on subtier suppliers.

## **5.9 CONTROL OF SPECIAL PROCESSES**

Subcontractor shall use trained and qualified personnel and qualified written procedures in accordance with specified requirements for the performance of certain special processes, including but not limited to, soldering, electronic assembly, brazing, welding, plating, heat treatment, nondestructive examination, etc. Copies of special process procedures shall be available for review by Princeton and submitted to Princeton for review and approval if requested.

## **5.10 NONCONFORMANCES**

The subcontractor shall promptly identify and control nonconforming items or services. Nonconforming items or services shall be positively identified, and segregated where possible, to prevent use. The subcontractor shall document each nonconformance. The written approval of Princeton is required prior to the use of the nonconforming item or service.

## **5.11 RELEASE FOR SHIPMENT FORM**

Subcontractor shall have a signed "Product Quality Certification and Shipping Release" Form to be provided by PPPL's Quality Assurance Representative prior to PPPL acceptance of procured items or services for full or partial shipment. PPPL reserves the right to refuse to accept shipments unless accompanied by a signed "Shipping Release" Form .

## **5.12 PROCESS HISTORY**

Subcontractor shall provide to PPPL a Process History which includes a compilation of documents, detailing the objective evidence of the acceptability of the work performed. The Process History shall include as a minimum, but not be limited to, the following:

5.12.1 **Material Certifications**

The Subcontractor shall submit copies of inspection reports, test data, and/or certifications from vendors, showing relevant chemical, mechanical and electrical properties of materials used, where applicable, as well as documents showing adherence to in-process requirements. Material certifications from sub-tier suppliers shall also be submitted.

5.12.2 **Inspection and Test Reports**

Copies of the original reports of all required inspections, tests and examinations, properly validated by authorized personnel.

5.12.3 **Fabrication Drawings**

Copies of the final fabrication “as built” drawings that include all approved changes made during the fabrication.

5.12.4 **Certificate of Compliance (C of C)**

Subcontractor's C of C, stating that the work performed conforms in every respect to the physical configuration and functional inspection/test requirements. The C of C shall be signed by Subcontractor's Quality Assurance (QA) Manager. Where Princeton-furnished material has been used by the Subcontractor, such certification shall also include the statement: "Material furnished by Princeton has been inspected by the Subcontractor and used by the Subcontractor as specified by Princeton with no unauthorized substitutions.

5.12.5 **Nonconformance Reports**

The subcontractor must submit copies of nonconformance or discrepancy reports, those affecting form, fit or function.

**5.13 PPPL RECEIVING/INSPECTION**

PPPL will perform Receiving Inspection on items or services supplied by Subcontractor, using either a sampling plan or 100% inspection. Discrepant items or services will be rejected and returned to Subcontractor or reworked by PPPL. Costs caused by rejects will be charged to Subcontractor.

**6.0 DOCUMENTATION REQUIREMENTS**

**6.1 PROPOSAL TECHNICAL DOCUMENTATION**

- a. Subcontractor shall submit as part of his proposal documentation in preliminary or outline form, the QA Plan (refer to section 5.3), the

Manufacturing/Inspection/Test Plan (refer to section 5.4), and procedures for tests (refer to section 5.5).

- b. Subcontractor shall submit as part of the proposal a preliminary description of the press mold, and assembly alignment fixtures which will be required to complete the assemblies.

## **6.2 DOCUMENTATION AFTER CONTRACT AWARD AND PRIOR TO FABRICATION**

- a. Subcontractor shall submit (2 copies) final versions of the QA Plan (refer to section 5.3), the Manufacturing/Inspection/Test Plan (refer to section 5.4), and procedures for tests (refer to section 5.5) for PPPL review and approval **within 30 days of contract award.**
- b. Subcontractor shall submit (2 copies) a final description of the press mold (refer to section 3.2.18) and assembly alignment fixture (refer to section 3.2.15) for PPPL review and approval **within 30 days of contract award.**
- c. Subcontractor shall submit (2 copies) of fabrication drawings for PPPL review and approval **within 30 days of contract award.**

## **6.3 DOCUMENTATION PRIOR TO SHIPMENT**

- a. Subcontractor shall submit (2 copies) all documents identified in section 5.12, Process History.
- b. Subcontractor shall submit an inventory of excess materials provided by PPPL.

## **7.0 SHIPPING STORAGE AND HANDLING**

- a. The conductor coolant tubes shall be drained of all water and sealed for storage and subsequent shipment.
- b. Each TF coil shall be individually crated for shipment. The crate shall be built for moving on rollers, handling with slings from overhead cranes and forklifts.
- c. The crate shall protect the coils from shock, damage from load shift, and weather conditions, including precipitation. Subcontractor's name, shipper, purchase order number, coil number and gross weight shall be marked on the shipping container. Subcontractor is responsible arranging shipment, and for the safe arrival of the PF coils at PPPL in Princeton, New Jersey, USA.

- d. The coils shall be prepared for shipment in such a manner as to ensure acceptance by common carrier for transportation at the lowest applicable rate and to afford protection from normal hazards of transportation.

## **8.0 DELIVERABLES**

The Subcontractor is responsible for delivering to PPPL the following:

- a. All documentation listed in section 6.0.
- b. Eighteen coil assemblies, which have successfully passed all acceptance tests and criteria.
- c. Balance of materials supplied by PPPL or which were procured by Subcontractor solely for this contract.
- d. Fixtures or tooling fabricated solely for the fabrication of the coils.