

SPECIFICATION

FOR

**Plasma Spray Ceramic Coating NCSX Modular Coil Shims
NCSX-CSPEC-142-06-00**

Revision 0

Dated 25 May 2007

PREPARED BY: _____
Cognizant Individual: R. Ellis

REVIEWED BY: _____
Quality Assurance: F. Malinowski

APPROVED BY: _____
RLM: L. Dudek

**PRINCETON UNIVERSITY
PLASMA PHYSICS LABORATORY
P. O. BOX 451
PRINCETON, N. J. 08543
609-243-2000**

1.0 SCOPE

This document describes the plasma sprayed ceramic coating of standard modular coil shims for the National Compact Stellarator Experiment (NCSX). The ceramic coating is to be used as a high friction surface as well as an insulator. PPPL will order a small lot of coated samples from multiple bidders, and verify that the resulting parts meet the electrical and mechanical requirements of the NCSX project. Those vendors whose samples meet the requirements will bid on the complete job, using the same coating materials and process used on the sample lot.

2.0 APPLICABLE DOCUMENTS

Drawing #SE140-199, Revision 0, "Flange Pull Shear Test Assembly"

3.0 REQUIREMENTS

3.1 STATEMENT OF WORK ACTIVITY

Ceramic coat components listed in table 1 with Al_2O_3 to a thickness of 0.012", with a tolerance of +.003"/- .002", on the surfaces indicated on the marked up drawing SE140-199, page 3 of 3. [attached] The drawing is dimensioned in inches inches.

The coating shall be applied to all surfaces, with the exception of the handling tabs at the ends of the shim, as indicated on the marked up drawing. The inside of the through hole shall be masked from coating.

The surface roughness on the outer surface shall be at least [rougher than] 100microinches rms.

The vendor shall submit the chemical composition of the coating and binder for approval as part of the bid.

All parts are 300 series stainless steel.

<u>Quantity</u>	<u>Part Number</u>	<u>Description</u>
800	SE140-199-8	Single Hole Shim

3.2 MATERIALS

The material used for coating shall be Aluminum Oxide (Al_2O_3). Purity shall be at least 99.4%.

3.3 Pre-qualification samples

Each bidder shall coat forty single hole shims, part SE140-199-8, provided by PPPL, as shown on the attached sketch, with Al_2O_3 to a thickness of .010", with a tolerance of +/- .005". The surface roughness of the coating shall be rougher than 100 microinches rms. The roughness will be measured with a

profilometer. Thickness measurements, before and after coating, shall be taken and recorded at two locations on each sample. Two of the samples will be sectioned in two locations.

4.0 TEST AND INSPECTION REQUIREMENTS

4.1 INSPECTION

Thickness measurements, between the large flat faces, shall be taken and recorded at two locations on each part before and after coating. These measurements shall be used to verify the coating thickness. A height gauge on a surface plate shall be used to verify the coating thickness on each face.

The surface roughness shall be measured using a profilometer.

4.2 ACCEPTANCE TEST

The following tests will be performed by PPPL on 100% of the production:

The coated parts will be vacuum baked by PPPL to 300 degrees Celsius. The rate of temperature rise during the acceptance test will not exceed five degrees Celsius per minute. Acceptable parts will not show any peeling or cracking.

The coated parts will be subjected to a cryogenic thermal shock test by sudden immersion into a liquid nitrogen bath. [70degrees Kelvin] Acceptable parts will not show any peeling or cracking.

The coating shall give a voltage standoff of at least 9V after the thermal acceptance tests. The electrical acceptance test shall be performed with two soft electrodes that conform to the large flat surfaces of the shim, and cover the full area of both surfaces. Acceptable parts will show a resistance of at least 100k Ω between each soft electrode and the parent metal.

4.3 Destructive tests: 5% sampling

5% of the specimens shall be sectioned, by PPPL, in two places for metallographic sections.

5.0 QUALITY ASSURANCE REQUIREMENTS

5.1 Inspection/ Surveillance/Audit By Princeton

Authorized representatives of Princeton and the U. S. Government shall have the right at all reasonable times to visit the Subcontractor's premises and those of Subcontractor's suppliers during the performance of the procurement for the purposes of inspection, surveillance, audit and/or obtaining any required information as may be necessary to assure that items or services are being furnished in accordance with specified requirements. Such visits shall be coordinated with the Subcontractor's personnel to minimize interference with

the normal operations of said premises. The Subcontractor shall make available records and documentation necessary for this function and shall provide all reasonable facilities and assistance for the safety and convenience of Princeton and/or U. S. Government representatives in the performance of their duties. Princeton and the U. S. Government recognize the Subcontractor's right to withhold information concerning proprietary processes. The Subcontractor agrees to insert the paragraph above into each lower-tier procurement issued hereunder.

5.2 Subcontractor's Responsibility For Conformance

Neither Princeton's review and/or approval of Subcontractor's documents nor Princeton's inspection of Subcontractor's items or services shall relieve the Subcontractor of responsibility for full compliance with requirements of the purchase order/contract.

The Subcontractor is responsible for assuring that all requirements and restrictions are imposed on any sub-tier suppliers.

5.3 Nonconformances & Corrective Actions And Notification Of Princeton

Nonconforming items shall be positively identified, and, where possible, segregated to prevent use. The Subcontractor shall document each nonconformance. The written approval of Princeton is required prior to the use of the nonconforming item or service.

5.4 Measuring and Test Equipment

Inspections and tests shall be performed using properly calibrated measuring and test equipment. Subcontractor shall have in its possession the necessary equipment to perform the required inspections and tests. Calibration standards shall be traceable to the National Institute for Standards and Technology (NIST) or equivalent.

5.5 Submittal of Completed Release For Shipment Form

Subcontractor shall have a signed "Product Quality Certification and Shipping Release" Form to be provided by Princeton's Quality Assurance Representative prior to acceptance of procured items for full or partial shipment. Princeton reserves the right to refuse to accept shipments unless accompanied by a signed "Shipping Release" Form (Exhibit 1).

5.6 Submittal of Completed Process History (Documentation Package)

Subcontractor shall deliver, along with each shipment of completed item(s), two (2) copies of the Process History, a compilation of documents, detailing the objective evidence of the acceptability of the work performed. Some parts of the Process History, typically inspection and test reports, may be required

with the Shipping Release request. The Process History shall include as a minimum, but not be limited to, the following:

5.6.1 Submittal of Subcontractor's Certificate Of Compliance (CofC)

Subcontractor's CofC, stating that the work performed conforms in every respect to the physical configuration and functional inspection/test requirements. Subcontractor's Quality Assurance (QA) Manager shall sign the CofC. Where the Subcontractor has used Princeton-furnished material, such certification shall also include the statement: "Material furnished by Princeton has been inspected by the Subcontractor and used by the Subcontractor as specified by Princeton with no unauthorized substitutions".

5.6.2 Submittal Of Material Certifications

The Subcontractor shall submit Material Test Reports showing actual relevant chemical, mechanical, and electrical properties of materials used and providing traceability to the actual material. One copy is to be submitted upon Subcontractor acceptance for use.

5.6.3 Submittal of Completed Inspection & Test Reports

Copies of the original reports of all required inspections and tests, properly validated by authorized personnel.

5.6.4 Submittal Of Completed Discrepancy Reports (Nonconformances, Corrective Actions)

The Subcontractor must submit copies of discrepancy reports, those affecting form, fit or function.

5.7 Handling, Packaging, Shipping And Storage

Subcontractor shall control items during handling and shipping and while in storage, including Princeton-furnished items, and shall assure that materials and items are adequately protected from damage or deterioration, with special attention to packaging for shipment. Such protection shall include special environmental packaging requirements as specified. Packaging, shipping and storage procedures shall provide for adequate marking or labeling to clearly and readily identify the items. Release from storage shall be controlled to prevent accidental or inadvertent use of incorrect or unacceptable items. Procedures may be subject to Princeton review and approval.

5.8 Princeton Receiving/ Inspection

Princeton will perform Receiving Inspection on items supplied by Subcontractor, using either a sampling plan or 100% inspection. Discrepant items or services will be rejected and returned to Subcontractor or reworked by Princeton.

6.0 DOCUMENTATION

Dimensional inspection reports [4.1] shall be documented and forwarded to PPPL. One copy will be provided as part of the shipping release process [5.5] and two copies shall be delivered with the parts.

7.0 DELIVERABLES

The ceramic coated parts, inspection reports, process histories including materials certifications, and a certificate of compliance will constitute the deliverables.

8.0 ATTACHMENTS

A marked-up portion of SE144-199, part #8, is attached.

ATTACHMENT – MARKED UP DRAWINGS

1. Single Hole Shim SE140-199-8

.5" handling area

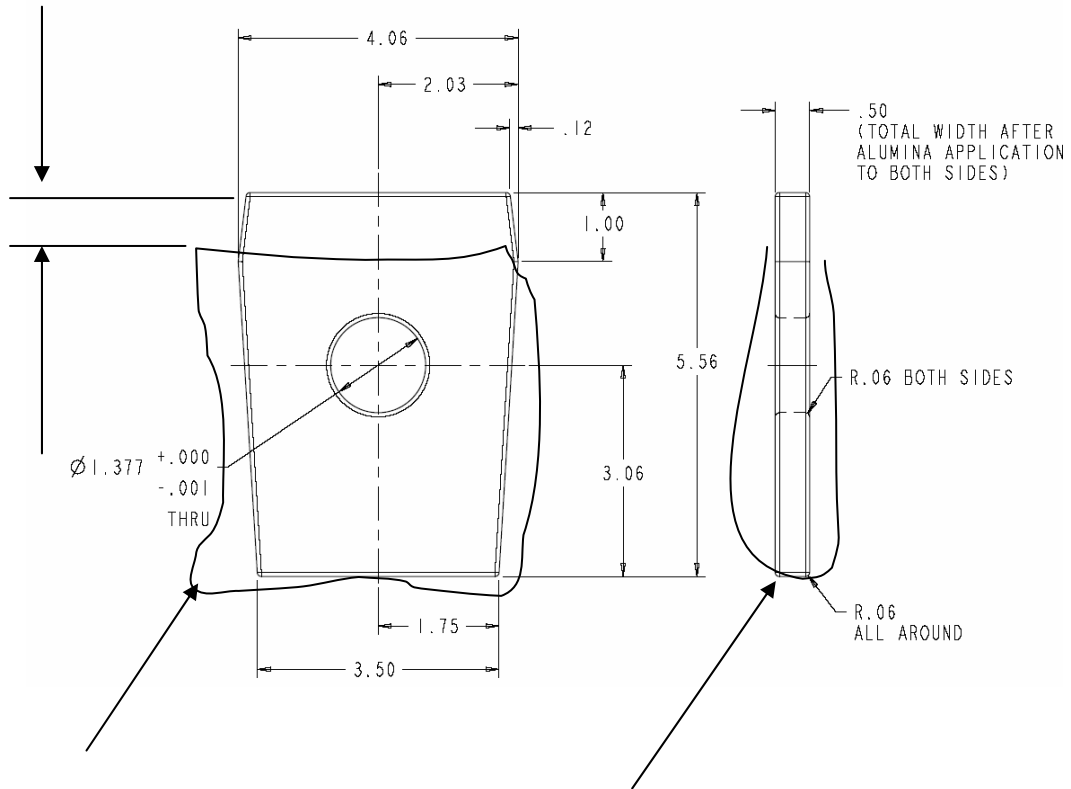

Coat large flat surfaces

Coat narrow edges and radii