

**NCSX**  
**Statement of Work**  
**Modular Coil Winding Forms**

NCSX-SOW-141-02-04

**June 29, 2005**

Prepared By: \_\_\_\_\_

P. Heitzenroeder, Technical Representative for Modular Coil (WBS 14) Procurements

Concurred By: \_\_\_\_\_

D. Williamson, WBS Manager for Modular Coils (WBS 14)

Concurred By: \_\_\_\_\_

B. Nelson, Project Engineer for Stellarator Core Systems (WBS 1)

Concurred By: \_\_\_\_\_

F. Malinowski, PPPL Procurement QA Representative

Approved by: \_\_\_\_\_

W. Reiersen, NCSX Engineering Manager

**Controlled Document**

*This is a controlled document. Check the NCSX Engineering Web prior to use to assure that this document is current.*

**REVISIONS**

<b>Revision No.</b>	<b>Description of Change</b>	<b>Date</b>
0	Initial Issue	6/30/2004
1	Revised Section 5.3 to delete cost reporting	8/6/2004
2	Revised Section 4.4; added Attachment II - Request for Deviation form	4/19/2005
3	Revised Section 5.4.3 to clarify dimensional inspection file format and contents	6/10/2005
4	Revised Section 5.5 to clarify retention requirements of CAD/CAM files	6/30/2005

# Table of Contents

- 1 GENERAL INFORMATION ..... 1**
- 1.1 Introduction ..... 1
- 1.2 Background ..... 1
- 1.3 Scope ..... 5
- 2 APPLICABLE DOCUMENTS ..... 5**
- 2.1 Product Specification ..... 5
- 2.2 Supplier Documents ..... 5
- 3 WORK REQUIREMENTS..... 5**
- 4 QUALITY ASSURANCE ..... 5**
- 4.1 Inspection/ Surveillance/Audit by PPPL ..... 5
- 4.2 Subcontractor's Responsibility for Conformance ..... 6
- 4.3 Nonconforming Items..... 6
- 4.4 Deviations to the Approved Manufacturing Inspection Test / QA Plan or Procedures..... 6
- 4.5 Subcontractor’s Quality Assurance Program..... 6
- 4.6 Inspection and Test Procedures ..... 7
- 4.7 Document Traceability and Records ..... 7
- 4.8 Equipment/Material Identification and Status ..... 7
- 4.9 Calibration of Test and Measuring Equipment..... 7
- 4.10 Control of Special Processes ..... 7
- 4.11 PPPL Receiving and Inspection ..... 8
- 5 DELIVERABLES ..... 8**
- 5.1 Prior to Fabrication Release ..... 8
- 5.1.1 MIT/QA Plan, and Associated Procedures..... 8
- 5.2 Weekly Reports..... 8
- 5.3 Monthly Reports..... 8
- 5.4 Modular Coil Winding Forms ..... 8
- 5.4.1 Final Product ..... 8
- 5.4.2 Shipping Release Form ..... 8
- 5.4.3 Process History..... 9
- 5.5 Tooling and Software ..... 9
- ATTACHMENT 1 –SHIPPING RELEASE FORM ..... 10**
- ATTACHMENT II. PPPL REQUEST FOR DEVIATION (RFD) FORM..... 11**

# List of Figures

Figure 1 - The NCSX Device and Identification of its Major Components ..... 2

Figure 2 - NCSX modular coil windings ..... 3

Figure 3 - Modular coil details..... 4

Figure 4 - Final assembly of the NCSX modular coil set ..... 4

## **1 GENERAL INFORMATION**

### **1.1 Introduction**

This Statement of Work is for the manufacture of the “production” winding forms for the National Compact Stellarator Experiment (NCSX). A total of eighteen (18) winding forms is required, comprised of 6 each of three winding form types. The winding forms are defined in Specification NCSX-CSPEC-141-03.

NCSX is the first of a new class of stellarators known as “compact stellarators.” Stellarators are a class of magnetic fusion confinement devices characterized by three dimensional magnetic fields and plasma shapes and are the best-developed class of magnetic fusion devices after the tokamak. The stellarator concept has greatly advanced since its invention by Dr. Lyman Spitzer, the founding director of the Princeton Plasma Physics Laboratory (PPPL), during the 1950’s. A traditional stellarator uses only external magnetic fields to shape and confine the plasma. The differentiating feature of a compact stellarator is the use of plasma current in combination with external fields to accomplish shaping and confinement. This combination permits a more compact stellarator design.

The NCSX project is managed by PPPL in partnership with the Oak Ridge National Laboratory. This Subcontract will be administered by PPPL. Further description of the NCSX can be found at <http://www.pppl.gov/ncsx/>.

### **1.2 Background**

Figure 1 is a sectional view of the NCSX device showing its major components. Note the modular coil set with an integral shell. The stainless steel winding forms that comprise this shell are the subjects of this SOW.

The modular coil windings are shown in Figure 2 without their associated winding forms to permit the complex shape of the windings to be more readily seen. There are three distinct shapes; six (6) of each make up the complete modular coil set. To fabricate these windings to the precise shapes required, stranded copper cable conductor is wound on the machined stainless steel winding forms, as shown in Figure 3. In addition to defining the shape of the coils, the winding forms also provide the strong structural support necessary to support electromagnetic loads as high as 7000 lbs. / in. Figure 4 shows the final assembly of the NCSX modular coil set.

*Note: Figures in this section are only for illustration and should not be used in the performance of this Scope of Work.*

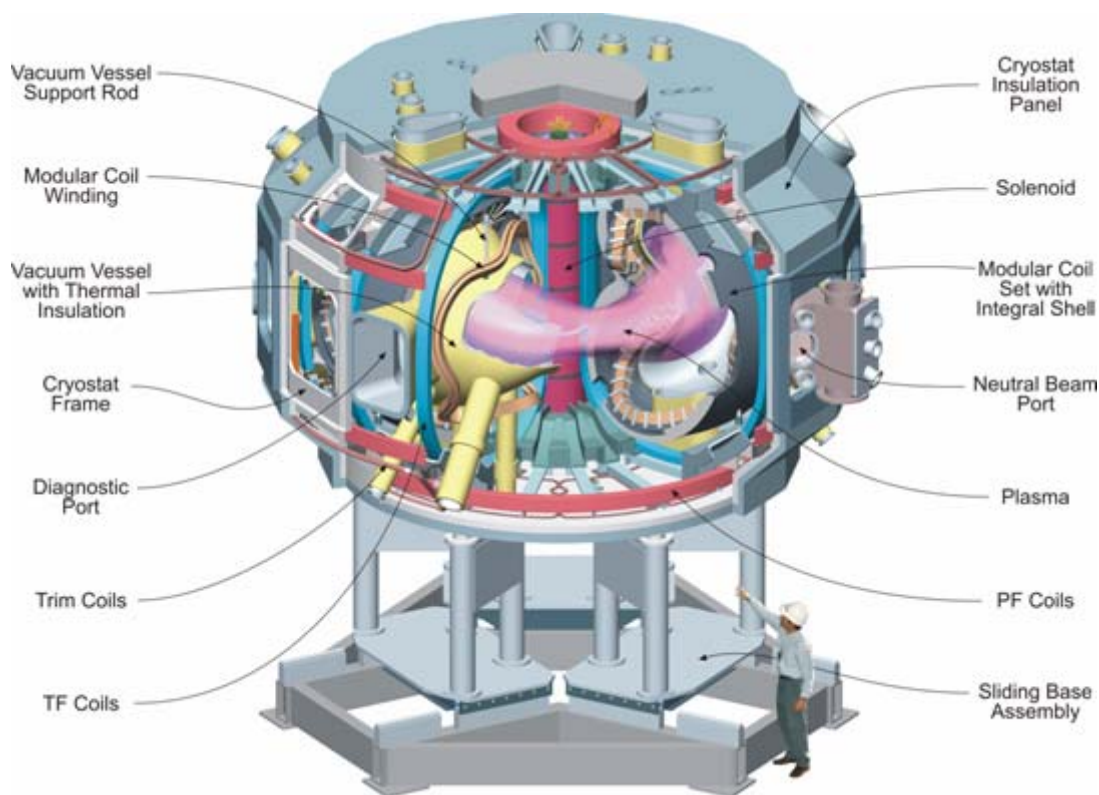

**Figure 1 - The NCSX Device and Identification of its Major Components**

*Note in particular the Modular Coil Set with Integral Shell. This integral shell is comprised of the (18) winding forms that are the subject of this SOW. A typical winding form is shown in Figure 3.*

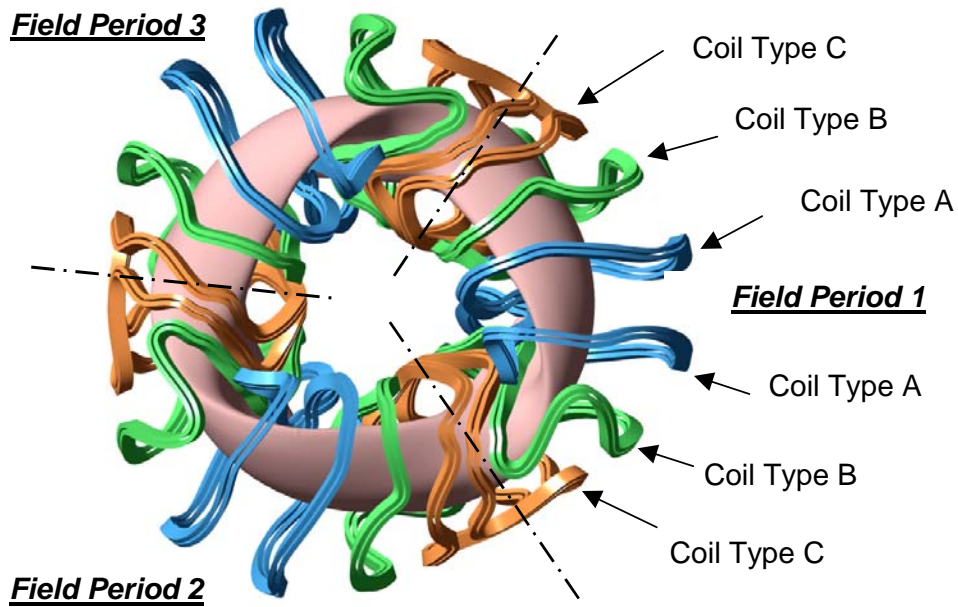

A. Top view, identifying coil shapes.



B. Side view at split line between periods

C. Side view looking into Type A coils

Figure 2 - NCSX modular coil windings

The windings are shown without their associated winding forms so their complex shapes can be easily seen. In order to manufacture these windings to their precise shapes, stranded copper conductor is wound on the machined winding forms (shown in Figure 3), which are the subject of this Statement of Work. Six of each of the three winding form shapes are required. (Dimensions in meters)

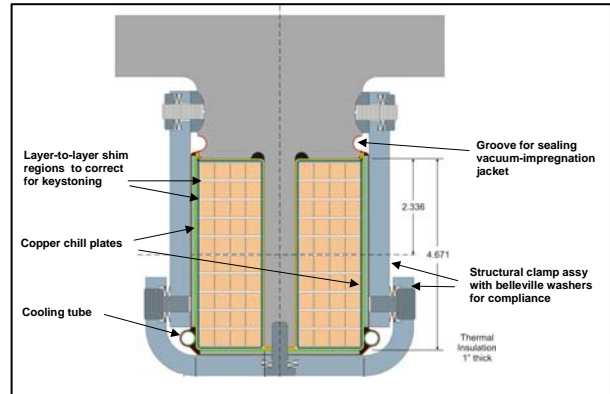
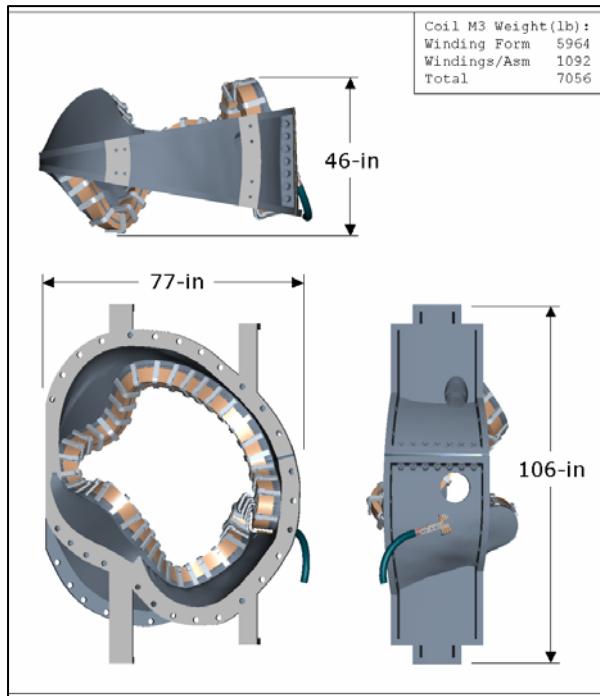

Figure 3 - Modular coil details

Shown is one of the three winding form types. The right view shows a sectional view of the form with the stranded cable conductor wound in place on both sides of the “T” section. The winding form serves two very important functions: it defines the precise shape of the winding and provides the required structural support.

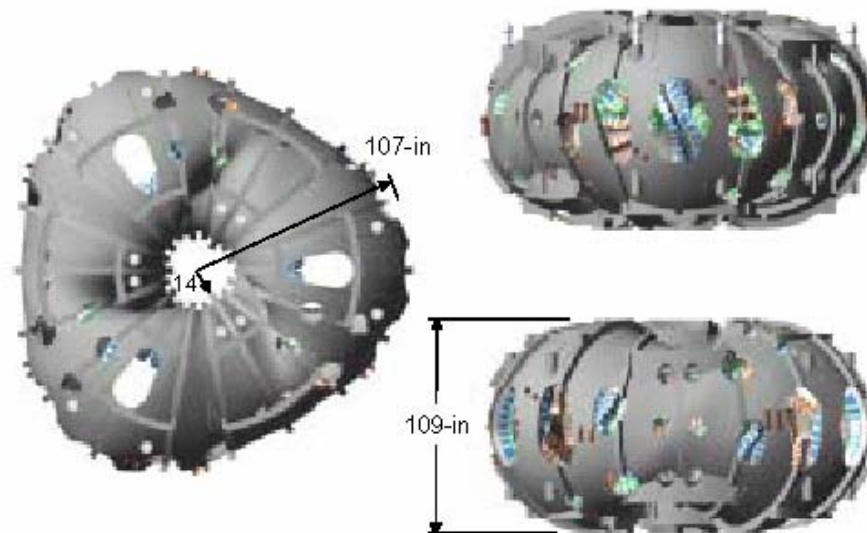

Figure 4 - Final assembly of the NCSX modular coil set

Shown above is the final assembly of the eighteen modular coils (six each of three coil shapes).



### **1.3 Scope**

This Scope of Work (SOW) addresses the manufacture of six (6) each of Type A, and Type B and five (5) Type C winding forms. This includes the casting, machining, poloidal break hardware, and all associated processing, testing, quality control, documentation, packaging, and shipping. This scope also includes all operations required to complete the Type C “production” winding form that was started under the offeror’s Manufacturing Development and Prototype Fabrication Subcontract. This completed winding form will become the sixth Type C winding form.

## **2 APPLICABLE DOCUMENTS**

### **2.1 Product Specification**

The applicable version of the product specification NCSX-CSPEC-141-03 and can be found at:

[ftp://ftp.pppl.gov/pub/ncsx/manuf/production\\_winding\\_form/](ftp://ftp.pppl.gov/pub/ncsx/manuf/production_winding_form/)

### **2.2 Supplier Documents**

The supplier-provided documents shall include PPPL-approved Manufacturing, Inspection, Test Plan/Quality Assurance (MIT/QA) Plan and associated procedures.

## **3 WORK REQUIREMENTS**

The supplier shall manufacture, inspect, test and deliver to PPPL (18) winding forms that shall conform to the applicable specification. Processing shall be in accordance with the supplier’s PPPL-approved Manufacturing, Inspection, Test and Quality Assurance Plan, and associated procedures. Supplier shall provide all process documentation identified in Section 5. NOTE: The “wing” regions of the winding forms contain the most highly stressed regions of the casting. Therefore, the supplier shall “bias” the flow solidification analyses to lessen the likelihood of voids, oxide inclusions, and shrinkage defects in these regions.

## **4 QUALITY ASSURANCE**

### **4.1 Inspection/ Surveillance/Audit by PPPL**

Authorized representatives of PPPL and the U. S. Government shall have the right at all reasonable times to visit the Subcontractor's premises and those of Subcontractor's suppliers during the performance of the Subcontract for the purposes of inspection, surveillance, audit and/or obtaining any required information as may be necessary to assure that items or services are being furnished in accordance with specified

requirements. Such visits shall be coordinated with the Subcontractor's personnel to minimize interference with the normal operations of said premises. The Subcontractor shall make available records and documentation necessary for this function and shall provide all reasonable facilities and assistance for the safety and convenience of PPPL and/or U. S. Government representatives in the performance of their duties. PPPL and the U. S. Government recognize the Subcontractor's right to withhold information concerning proprietary processes. The Subcontractor agrees to insert the paragraph above in each lower-tier procurement issued hereunder.

#### **4.2 Subcontractor's Responsibility for Conformance**

Neither PPPL review and/or approval of Subcontractor's documents nor PPPL inspection of Subcontractor's items or services shall relieve the Subcontractor of responsibility for full compliance with requirements of the purchase order/contract. The Subcontractor is responsible for assuring that all requirements and restrictions are imposed on any sub-tier suppliers.

#### **4.3 Nonconforming Items**

Nonconforming items shall be positively identified, and, where possible, segregated to prevent use. PPPL must be notified of nonconformances within one (1) business day. The Subcontractor shall document each nonconformance, identifying the extent and location of the nonconformance and proposing a disposition. The written concurrence of PPPL is required prior to implementing the disposition. The Subcontractor's system shall provide not only for timely resolution of nonconformances but also for analysis of nonconformances to determine root causes and to implement appropriate and effective corrective actions.

#### **4.4 Deviations to the Approved Manufacturing Inspection Test / QA Plan or Procedures**

Deviations to the approved documents shall be included in the weekly report. The Subcontractor is required to obtain PPPL's written approval for deviations which may adversely affect conformance to the contracted delivery schedule or product specification. Deviations requiring written approval are to be submitted on the PPPL Request for Deviation form (Attachment II).

#### **4.5 Subcontractor's Quality Assurance Program**

The Subcontractor shall maintain an effective Quality Assurance Program to assure that the Subcontractor's work meets the required quality and is performed in accordance with contractual requirements. Subcontractor's quality assurance function shall be actively involved in the planning, processing oversight, problem resolution, and determination of acceptability of all work under this SOW. The function shall be organized to have sufficient authority and independence to identify quality

problems, verify conformance of supplied items or services to specified requirements and obtain satisfactory resolution of conflicts involving quality.

#### **4.6 Inspection and Test Procedures**

Inspections and tests shall be performed in accordance with written procedures referencing criteria for acceptance or rejection. Except where specifically stated otherwise, actual data and accept/reject status for each inspection and test shall be documented. Reports shall clearly identify the item inspected, the locations or areas covered by the report, the performing individual, the date performed, equipment used (with calibration status), and the signature of the authorized individual.

#### **4.7 Document Traceability and Records**

The Subcontractor shall maintain a system of documentation whereby objective evidence of required operations, inspections, examinations, and tests is systematically compiled, indexed, stored and ultimately provided to PPPL per paragraph 5.4.3, Process History. Such objective evidence may include "travelers"; and material test, certification, inspection, examination, test and nonconformance reports; which shall be complete, legible, and validated by responsible personnel and shall be traceable to subject items.

#### **4.8 Equipment/Material Identification and Status**

Material and equipment identification shall be maintained throughout the program and be traceable to records. Status of acceptability shall be readily discernible through the Subcontractor's use of tags, stamps, serial numbers or other positive means.

#### **4.9 Calibration of Test and Measuring Equipment**

Inspections and tests shall be performed using properly calibrated measuring and test equipment. Subcontractor shall have in its possession the necessary equipment to perform the required inspections and tests. Calibration standards shall be traceable to the National Institute for Standards and Technology (NIST) or equivalent acceptable to PPPL and shall not be used for shop inspections, but instead be protected against damage or degradation.

#### **4.10 Control of Special Processes**

Subcontractor shall use trained and qualified personnel and qualified written procedures in accordance with specified requirements for the performance of certain special processes, including but not limited to, welding, dimensional inspection, heat treatment, nondestructive examination, etc. Copies of special process procedures and personnel qualifications shall be submitted to PPPL for review and approval a minimum of five (5) working days prior to performance of the work.

#### **4.11 PPPL Receiving and Inspection**

PPPL will perform Receiving Inspection on items supplied by Subcontractor.

### **5 DELIVERABLES**

#### **5.1 Prior to Fabrication Release**

##### **5.1.1 MIT/QA Plan, and Associated Procedures**

The Supplier shall provide their MIT/QA plan and all associated procedures to PPPL for approval prior to beginning fabrication

##### **5.2 Weekly Reports**

Brief weekly status reports covering technical, administrative, and quality activities and notable problems/issues and progress photographs. Periodically, when requested by the Princeton Technical Representative, the report will include the percent completion of the work for the next milestone deliverable.

##### **5.3 Monthly Reports**

The Subcontractor shall prepare and submit monthly e-mail reports indicating schedule progress for each task/deliverable planned.

- The Subcontractor shall submit a milestone schedule that clearly indicates the tasks to be accomplished and the time frame over which each task will be accomplished.
- The Subcontractor shall report (e-mail report satisfactory) schedule progress against each milestone by indicating actual and forecast finish dates. A narrative explanation of schedule delays shall also be provided.

#### **5.4 Modular Coil Winding Forms**

##### **5.4.1 Final Product**

The supplier shall deliver to PPPL (18) winding forms that shall conform to the applicable specification.

##### **5.4.2 Shipping Release Form**

Prior to shipment of each winding form, the Subcontractor must have submitted to PPPL a completed and signed "Product Quality Certification and Shipping Release" form (Attachment 1 of this SOW), along with a copy of the Process History (ref. Paragraph 5.4.3), and received from PPPL written acceptance to ship.

### **5.4.3 Process History**

Subcontractor shall provide to PPPL one (1) "paper" copy or one (1) "electronic" copy of the Process History, which includes a compilation of documents, detailing the objective evidence of the acceptability of the work performed. The Process History shall be complete and available at the time the Subcontractor requests Release for Shipment. The Process History shall include as a minimum, but not be limited to:

- Material certifications
- Heat treatment charts
- Welding procedures and procedure qualification test records
- Completed nonconformance reports
- Validated inspection and test reports, including radiographs, inspection grid, point grid files of each MCWF (STEP and IGES format), including the location of fiducials as required in the Product Specification for the Modular Coil Winding Form (NCSX-CSPEC-141-03-00) section 3.3.2.2 "Fiducials".
- Completed shop travelers or process sheets
- Personnel qualifications for Special Processes (Non Destructive Examination, welding, etc.)
- Signed Shipping Release

### **5.5 Tooling and Software**

All tooling and software specially fabricated /generated for the performance of this SOW shall become the property of the United States Government. Disposition will be per direction of PPPL.

The supplier shall maintain any CAD/CAM files generated in the performance of this SOW for a period of at least three years from the end of the contract.

**ATTACHMENT 1 –SHIPPING RELEASE FORM**

**PLASMA PHYSIC LABORATORY—PPPL**

PRODUCT QUALITY CERTIFICATION AND SHIPPING RELEASE					
PROJECT	ITEM DESCRIPTION			SHIPMENT NUMBER	
PPPL SUBCONTRACT/ ORDER NO.	REV .	ITEM NO.	SUPPLIER REFERENCE NO.	REV .	QUANTITY SHIPPED
<u>SUPPLIER'S CERTIFICATION</u>					
<p>This is to certify that the products and services identified herein have been produced under a controlled quality assurance program and are in conformance with the procurement requirements including applicable codes, standards and specifications as identified in the above-referenced documents unless noted below. Any supporting documentation will be retained in accordance with the procurement requirements.</p> <p>SIGNED: _____ DATE: _____</p> <p>TITLE: _____ COMPANY: _____</p>					
<u>PPPL (AUTHORIZED REPRESENTATIVE) SHIPPING RELEASE</u>					
<p>This is to certify that evidence supporting the above Supplier's Certification statement has been audited and no product/service nonconformances from procurement requirements have been found unless noted below. This product/service is hereby released for shipment.</p> <p>This section serves as the Quality Assurance release for the above described product for shipment. It does not constitute an acceptance thereof and does not relieve the Vendor, Manufacturer or Contractor of any and all responsibility or obligation imposed by the purchase contract. It does not waive any rights the Purchaser may have under the purchase contract, including the Purchaser's right to reject the above described material upon discovery of any deviations from requirements of the purchase contract, drawings and specifications.</p>					
NONCONFORMANCES FROM PROCUREMENT QUALITY REQUIREMENTS:					
REMARKS/PRODUCT SERIAL NUMBERS:					
BY PPPL QA REPRESENTATIVE (OR DESIGNEE)				DATE	

**ATTACHMENT II. PPPL REQUEST FOR DEVIATION (RFD) FORM**

<p><i>NCSX RFD</i></p> <p><i>Part I</i></p>	<p><b>Number:</b></p>	<p><b>RFD Description:</b></p>
<p><b>Initiator:</b></p>		<p><b>Organization:</b></p>
<p><b>List of Impacted Documents:</b> <i>(Specification, MIT/QA Plan, SOW, drawing, etc.)</i></p>		
<p><b>Cost Impact:</b> <i>(If none, so state)</i></p>		
<p><b>Schedule Impact:</b> <i>(If none, so state)</i></p>		
<p><b>Quality Impact:</b> <i>(If none, so state)</i></p>		
<p><b>State Requirement Deviation is Requested For:</b> <i>(Specification, MIT/QA Plan, SOW, drawing, etc.)</i></p>		
<p><b>Full Description of the Deviation Requested:</b> <i>(Use continuation pages, e-mails, letter, sketches, etc. as needed and include amplifying information as appropriate to support deviation request.)</i></p>		
<p><b>Attachments:</b></p>		
<p><b>Initiator Signature:</b> _____ <b>Date:</b> _____</p>		